

# Wireless Loadshackle

Internal Antennae  
Wireless Range of  
1000m or 3280ft

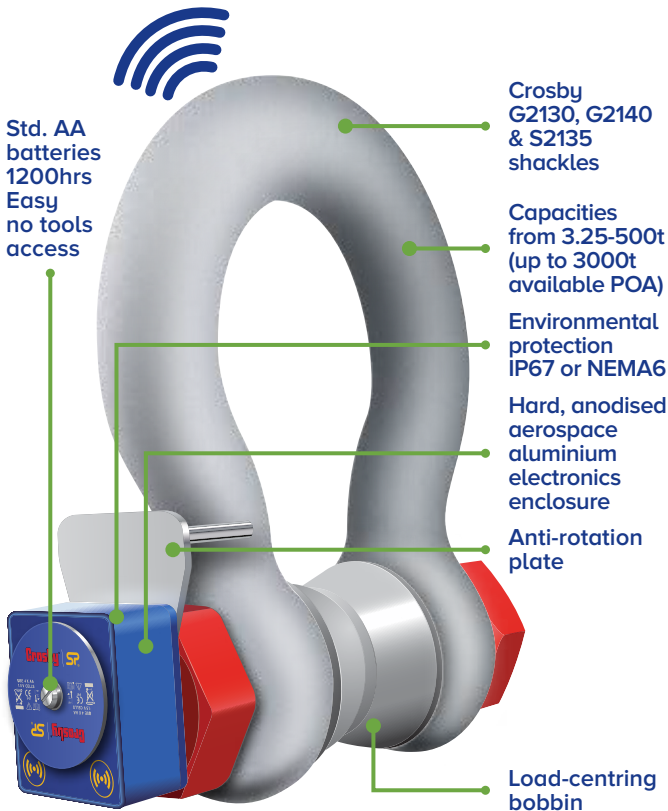

## Features and benefits:

- Wireless Range of 1000m or 3280ft
- Electronics housed in hard anodised enclosure
- Environmentally sealed to IP67 or NEMA6
- Battery Life of 1200hrs from 4 x AA batteries
- Internal Antennae
- Remote On-Off from handheld display or software
- Supplied with a load-centring bobbin
- 2-year warranty
- Complies with ASME B30.26
- Design validated by F.E.A.
- ATEX Zones 0, 1 & 2 available
  
- Bluetooth option is available and is supplied with a free HHP App for iOS and Android  
See page 21

**Straightpoint's Wireless Loadshackle (WLS) provides the perfect solution to limited headroom or super heavy lift projects. Available from stock in capacities from 3.25t to 500t (up to 3000t available POA), the WLS is constructed using industry-leading shackles from Crosby.**

### Three versions of the WLS are available:

- Long range 2.4GHz version providing industry-leading wireless range of 1000m or 3280ft to SP's SW-HHP handheld or software options.
- Bluetooth output and can be connected to any smart phone running SP's free HHP app on iOS or Android, at ranges up to 100m or 328ft.
- ATEX/IECEX for hazardous areas, zones 0, 1 & 2. Providing a wireless range of up to 500m or 1640ft to SW-HHP-ATEX handheld.

Each WLS is proof tested, then equipped with a hard-anodised aluminium electronics enclosure. Contained within this enclosure is an internal chassis providing IP67 or NEMA6 environmental protection, even with the battery cover plate missing.

Featuring industry leading wireless technology, the WLS can maintain an update rate of 3Hz. It can be easily configured to run at industry-leading speeds of up to 200Hz, if required for dynamic load measurement projects.

Utilising easily sourced AA alkaline batteries, the WLS features advanced circuitry, designed to protect the unit from damage associated with incorrectly installed batteries. This circuitry extends battery life, and the use of easily-sourced alkaline batteries, eliminating issues associated with rechargeable battery pack charging, failure and replacement.

The WLS may also be used with Straightpoint's SW-PTP software package, allowing the operator to perform load tests at a safe distance and generate real-time test certificates on site.

A full array of wireless accessories are also available including wireless score board, overload alarm and base station with analogue (4-20mA) or 2 relay or RS485 ASCII outputs.

Also available with hazardous area approval. Zones 0, 1 & 2



## ATEX / IECEx

Ex ia II C T4 Ga

Certification numbers:

**WLS ATEX**

IECEX SIR 16.0041X / Sira 16ATEX2108X

**SW-HHP ATEX**

IECEX SIR 15.0072X / Sira 15ATEX2196X

**Add 'ATEX' to the part number when ordering ATEX/IECEX products. For example: WLS3.25T-ATEX**

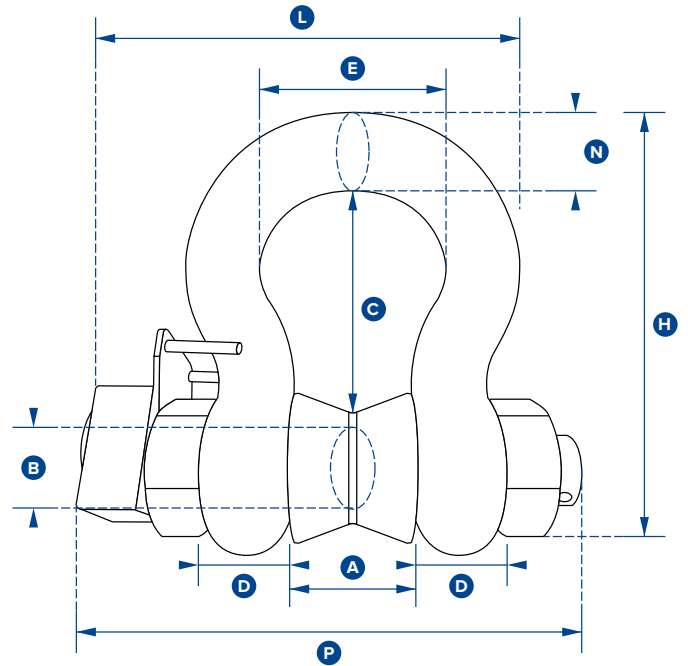

Part Numbers										
SP	WLS3.25T	WLS6.5T	WLS12T	WLS25T	WLS55T	WLS85T	WLS120T	WLS200T	WLS300T	WLS400T
Crosby	2789186	2789200	2789183	2789185	2789199	2789201	2789172	2789184	2789188	2789189
Capacity	3.25te 7150lb	6.5te 14300lb	12te 26400lb	25te 55000lb	55te 120000lbs	85te 185000lbs	120te 260000lbs	200te 440000lbs	300te 660000lbs	400te 880000lbs
Resolution	0.005te 10lb	0.005te 10lb	0.01te 20lb	0.02te 50lb	0.05te 100lb	0.05te 100lb	0.1te 200lb	0.2te 200lb	0.5te 1000lb	0.5te 1000lb
Units	tonne lb									
Weight	2.8kg 6.16lb	3.2kg 7lb	8kg 17.6lb	18kg 40lb	25kg 55lb	45kg 99lb	85kg 187lb	260kg 573lb	405kg 893lb	662kg 1459lb
Safety Factor	5:1 when used with load bobbin									
Battery Type	Load cell 4 x AA Alkaline									
Battery Life	Load cell 1200 hours continuous (500 hours if Bluetooth)									
Operating Temp	-20°C to +70°C or 4°F to 158°F									
Accuracy	±1% full scale									
Frequency	2.4 GHz									
System Range	1000 metres or 3280 feet (100 metres or 328 feet if Bluetooth) (500 metres or 1640 feet if ATEX/IECEX)									
Data Rate	3 updates per second									
Protection	IP67 or NEMA6									
Dimension A	26.9 1.06"	36.6 1.44"	51.5 2.03"	73 2.87"	82.5 3.25"	105 4.13"	127 5.00"	180 7.09"	205 8.07"	230 9.06"
Dimension ØB	19.1 0.75"	25.4 1.00"	35.1 1.38"	51 2.01"	57 2.24"	70 2.76"	82.5 3.25"	125 4.92"	150 5.91"	175 6.89"
Dimension C	56.9 2.24"	79.7 3.14"	113 4.45"	170 6.69"	189.5 7.46"	253 9.96"	319.5 12.58"	432.2 17.02"	505 19.88"	547.7 21.56"
Dimension D	16 0.63"	22.4 0.88"	31.8 1.25"	44.5 1.75"	51 2.01"	66.5 2.62"	76 2.99"	110 4.33"	120 4.72"	160 6.30"
Dimension E	42.9 1.69"	58 2.28"	82.5 3.25"	127 5.00"	164 6.46"	184 7.24"	200 7.87"	280 11.02"	305 12.01"	325 12.80"
Dimension H	106 4.17"	148 5.83"	210 8.27"	313 12.32"	348 13.70"	453 17.83"	546 21.50"	738 29.06"	862 33.94"	962.6 37.90"
Dimension L	127.1 5.00"	156.5 6.16"	196 7.72"	281 11.06"	306 12.05"	368 14.49"	408 16.06"	529.7 20.85"	586.7 23.10"	667.2 26.27"
Dimension N	17.5 0.69"	24.6 0.97"	35.1 1.38"	57 2.24"	61 2.40"	79 3.11"	92 3.62"	120 4.72"	140 5.51"	160 6.30"
Dimension P	143 5.63"	173 6.81"	218 8.58"	293 11.54"	317 12.48"	394 15.51"	441 17.36"	600 23.62"	657 25.87"	765 30.12"
Crosby Shackle	G2130				G2140			S2135		