



PORTAGANTRY RAPIDE™

➤ Assembly & Operation Guide

> Contents

Correct Operation	4	ATEX	19
Intended Use		ATEX	
Maximum Capacity		Classification [Zone 2]	
Inspection Prior to Initial Operation		Classification [Zone 1]	
Inspection Before Starting Work		Spark Formation	
Temperature Range		Static Electricity	
Notes for Correct Operation		Inspection, Maintenance & Repair	
Warning			
Fall Protection Applications	7	Notes	21
Use as a Fall Protection Anchor		Assembly Instructions	22
Additional Notes for Correct Operation		Dimensions	32
Warning		Quality & Safety	36
IRATA		Regulations, Standards & Directives	
		Accreditations	
Inspection & Maintenance	18	Conformité Européenne [CE]	
Regular Inspections		Testing	
Maintenance & Repair		Language	
Storage & Transportation		Product IPR	
		Product Labelling	38
		Inspection Record	39

Lightweight. Portable. **Safe.**

Please read the following instructions and guidance notes carefully, before using or operating the system. They contain important information about how to handle and use the system in a safe and efficient way, avoiding danger, reducing repair costs and downtime, and increasing the reliability and lifespan of the system.

They apply for:

- Operation, including preparation, troubleshooting during operation and cleaning
- Maintenance, inspection and repair
- Transportation

It is the responsibility of the end user to adhere to the Health & Safety and accident prevention standards and legislation valid in their respective countries and any regions in which the system is being used. A rescue plan also needs to be in place in the event of an emergency that could occur during the work. This document should form part of the overriding Risk Assessment and Method Statement required for each lift.

➤ Correct Operation

Intended Use

This product is designed, tested and intended to be used for the lifting of goods, the lifting of personnel or for providing a safety anchor for the prevention of falls as part of a personal fall protection system. (PFAS). The use of our products for these multiple applications is consistent with the products design, notwithstanding pre-user inspections and mandatory inspections by a competent or qualified person, determined by local regulations.

Maximum Capacity

Lifting of Goods: Each product will be marked with a capacity label. The capacity is specifically intended as a maximum limit for the lifting of goods, materials and equipment and includes safety factors. When using modular gantries, due to the interchangeability of A-frames and beams to suit the customers need, the lowest rated element of the gantry always takes precedent. A-frames are independently marked with a capacity label for safety.

Lifting of Personnel: For the lifting of personnel REID Lifting will reduce the capacity by half, thereby increasing the safety factor of the product. As for lifting goods, materials and equipment, the lowest rated element of the gantry always takes precedent. Associated equipment used for lifting personnel must be rated accordingly. It is the employers' responsibility to ensure this is the case. For example, a winch must be personnel rated and where necessary, meet applicable standards and regulations for the country of use.

Fall Protection Anchor: In most cases (subject to labelling and instructions for use for specific products confirming this) REID lifting products are tested and meet the requirements of fall protection standards and regulations, including ANSI Z359.18-2017 and various OSHA Regulations as referenced in our Instructions for Use. The capacity on the beam or A-frame is of no relevance to fall protection standards and requirements and the user should refer to the specific sections of the instructions for use, for detailed information. For example, ANSI requires that anchors that form part of a personal fall protection system are capable of withstanding a 5000lb static load (22.2kN) for a single user, 7500lb (33.3kN) for two users and 10,000lb (44.4kN) for three users and so on. OSHA requires a minimum safety factor of 2, validated by a qualified person. REID Lifting products will, where applicable be marked with the rating for fall protection. Safety factors will be higher than those for lifting and forces will be limited by the use of personal fall protection equipment, including load limiting devices such as shock absorbers or self-retracting lifelines that reduce impact forces, typically between 4kN and 8kN per user as required by law.

Note: some jurisdictions may not allow the same equipment to be used for lifting of materials and as a component of a PFAS. Some employers may also prefer to keep such equipment distinctly separate. If this is the case, we would recommend that the equipment is labeled accordingly. Check your local regulations before putting equipment to use and designate accordingly.

It is expected that all users of this product have the necessary medical and physical capabilities, are fully trained and deemed competent in its safe assembly and use. We would remind users of the requirement to ensure that work is properly planned, risk assessments carried out and as required, method statements for carrying out work provided.

Where required the owner/user of the equipment should ensure that a qualified person has been consulted in respect of the need for structural validation, for example (but not limited to); calculating imposed loads for the safety of ground, floor or roof structures during lifting operations.

Please refer to the below table for information on capacities and ratings for goods and personnel lifting. If you are unsure on the system, consult the serial labels on page 39 or consult your supplier.

PORTA GANTRY RAPIDE Maximum Capacity			
Part Code	Unit Weight [lb]	Capacity	
		Goods Capacity [lb]	Personnel Positioning [lb]
US-PGRS20	73	1100	550
US-PGRS23	77	880	440
US-PGRS40	88	550	275
US-PGRM20	77	880	440
US-PGRM23	79		
US-PGRM40	90	550	275
US-PGRT20	86		
US-PGRT23	88		
US-PGRT40	99		
US-PGR1TS20	99	2200	1100
US-PGR1TS30	117	2200	1100
US-PGR1TS40	128	2200	1100
US-PGR1TM20	108	2200	1100
US-PGR1TM30	119	2200	1100
US-PGR1TM40	130	2200	1100
US-PGR1TT20°	117	2200	1100
US-PGR1TT30°	128	2200	1100
US-PGR1TT40°	137	2200	1100

For fall protection applications see page 7.

Inspection Prior to Initial Operation

This product must be inspected prior to initial operation by a competent person to ensure that the structure is safe and that it has not been damaged by incorrect assembly, transport or storage.

Inspection Before Starting Work

Before starting work, the assembly of the product and all load-bearing components should be checked for visual defects. This includes checking the integrity of all profiles for denting, making sure there is no wear or elongation on the bolt holes and ensuring that the trolley moves freely along the beam.

Temperature Range

This product can be operated in ambient dry temperatures between -10°F and 131°F (-23° and +55°C). Consult your supplier in case of extreme working conditions.

Notes for Correct Operation

- For optimum safety, we recommend single person assembly to avoid conflicting actions.
- Assemble only as instructed (ensure all bolts and pins are present and fitted correctly as per instructions).
- Suitable, appropriately rated winches, hoists and bracket plates must be used for all applications.
- The product should be set up at a safe distance from the hazard or lift area, before moving the structure into place.
- The supporting ground/structure where the Gantry is to be used must be stable and capable of withstanding the maximum expected load applied during use.
- We recommend that the correct PPE is worn when using the equipment.
- The beam must be horizontal prior to any lift and A-Frames vertical and parallel to each other.
- Do not use the product if the trolley does not run freely along the beam. (For certain applications, such as when the system is being used as a restraint point, the trolleys can be locked into position).

➤ Correct Operation

- Attach hoists to the lifting point on the trolley only, making sure it is attached in a way that does not expose the user to danger by the hoist, chain or load.
- When lifting, keep the load low to the ground.
- Only raise and lower loads when castor brakes are engaged.
- Do not allow loads to swing.
- To avoid side pull, lowering and lifting should only be carried out when the load chain forms a straight and vertical line between the load and lifting attachment point on the trolley. If a vertical lift is not possible you must ensure that the load is within the footprint of the Gantry A-Frames (refer to figure A).

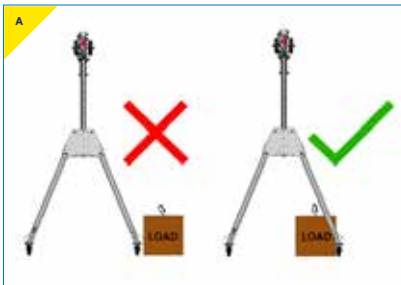

- We recommend the use of load-sensing or overload protection devices on all lifts.
- The product should not be moved under load except when a competent person or authority has approved a risk assessment and method statement.
- The risk assessment and method statement must take into account any factors that might apply additional loading to the system during lifting operations.
- Take care when transporting and storing the system to avoid damage.

Warning

- The equipment should not be used outside of its limitations, or for any purpose other than that for which it is intended.
- Do not lift or transport loads while personnel are in the danger zone.
- Do not allow personnel to pass under a suspended load.
- Never leave a suspended load unattended.
- Do not start moving the load along the beam until you have checked that it has been attached correctly.
- When moving a loaded trolley along the beam, move the load steadily and in a controlled manner and avoid sudden movements.

- Don't allow the load to hit the system frame.
- When winching, only use one winch with each sheave and make sure they never cross paths with each other.
- Be aware of any adverse weather conditions such as strong or gusty winds which could impose additional horizontal loads and affect the stability of the structure. Stop using if weather is impacting on lifting, and either disassemble the gantry or tie it to a rigid structure to ensure it can't overturn.
- Be aware of hazards when setting up/folding down, such as trapping fingers in rotating parts.

Note: The Rapide Tall Systems are fitted with trolley stops on the beam (see below). This is a safety feature and must always be in place before use. If beam length adjustment is required, stops must be repositioned accordingly.



➤ Fall Protection Applications

Use as a Fall Protection Anchor

This section must not be read in isolation from all other sections of this manual. Read the whole manual before using this product.

Fall arrest: This product is tested and conforms to the requirements of ANSI Z359.18 type D for fall arrest protection for a single user subject to the configuration of the product and the Davit being used. This product can also be used as part of a personal fall protection system that meets the requirements of OSHA 1910 subpart I, OSHA 1910.66 Appendix C (I) and OSHA 1926.502 subpart M. When being used for fall arrest purposes, the operator must use a body harness and a shock absorber that complies with the relevant national standards and regulations and that limits the maximum allowed force (m.a.f.) to 8kN.

Each personnel lift must be properly planned, and all weights clearly known along with a clear understanding of the capacity and constraints of all personal fall arrest system components.

The capabilities stated in the table below apply to standard range systems only. If unsure about your system consult serial labels, information filled in on page 39 or consult your supplier.

Custom versions of the system are available tailored to specific lifting needs. These versions are designated with a 'C' at the end of the product number on the serial label attached to each product.

Please refer to the below table for information on capacities and ratings for fall arrest. If you are unsure on the system, consult the serial labels on page 39 or consult your supplier.

PORTA GANTRY RAPIDE Fall Arrest		
Part Code	Unit Weight	Capacity
	[lb]	Fall Arrest Capacity* No of Person(s)
US-PGRS20	73	1
US-PGRS23	77	1
US-PGRS40	88	0
US-PGRM20	77	1
US-PGRM23	79	
US-PGRM40	90	0
US-PGRT20*	86	
US-PGRT23*	88	
US-PGRT40*	99	
US-PGRITS20	99	2
US-PGRITS30	117	2
US-PGRITS40	128	1
US-PGRITM20	108	2
US-PGRITM30	119	2
US-PGRITM40	130	1
US-PGRITT20*	117	1
US-PGRITT30*	128	1
US-PGRITT40*	137	1

* Only Applicable to the product being used in accordance with ANSI Z359.18. The system can support more users in Fall arrest if used in accordance with OSHA 1910 Subpart I or 1926 Subpart M. Please contact REID Lifting for further details

Additional Notes for Correct Operation & Warnings

- When using the product as part of a PFAS in accordance with OSHA or as an ANSI Z359.18 anchor point the leg straps MUST be fitted.
- The anchorage must always be above the users head to prevent dangerous free falls.
- Always carry out pre-use checks before using this equipment. It is advised to use a buddy system and inspection must be by a competent person.
- The fall arrest device must only be attached to the lifting point on the trolley or the designated location on the cheek plate or upright (see product images and set up instructions).
- Only use the product for fall arrest applications when the castor brakes are engaged.
- To ensure stability of the structure, the operating span of the beam must be equal to or greater than the distance between the castors on the A-Frames.

➤ Fall Protection Applications

- Never walk away from the footprint of the product or move outside designated safe zones whilst connected to it where there is a risk of a fall (refer to figure B). Ensure that the operating area is within the footprint of the system before beginning work.

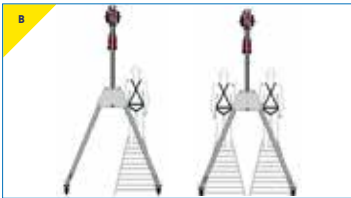

- When using the product as a fall arrest anchor ensure there is adequate fall clearance when working at height (refer to figure C). A competent person should calculate this taking into account all of the components of the personal fall arrest system and allowing a safety margin.

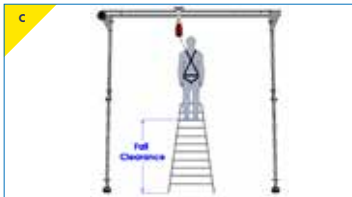

- Always consider the potential effects of sharp edges, chemical reagents, electrical conductivity, cutting, abrasion, climatic exposure on all components of the fall protection system, and the effect of offset forces as a result of pendulum falls.
- Ensure the structure on which the product is mounted is horizontal. If necessary, adjust the products feet to achieve a level operating structure.
- If the product has been subjected to a fall arrest or impact force it must be immediately removed from service.
- The substrate of the structure on which the product is placed must be able to sustain the loads specified for the device in all orientations permitted, including a safety factor of at least 2.
- Never exceed the number of allowable users.
- Never adjust the product whilst a person is attached to it.
- Only use designated anchor points for the attachment of fall protection devices.
- Ensure that any fall protection system components being used are compatible and meet the requirements of applicable standards.
- When using this equipment ensure that there is a rescue plan prior to starting work and ensure that users are trained in the correct execution of the plan and have all necessary rescue equipment to hand.
- Where required by regulation, each installation must be approved by a qualified person.
- Always wear appropriate PPE when installing, setting up, dismantling and using this equipment.
- Misuse of this product could result in serious injury or death.

Warning

- For fall protection applications the maximum user weight is 330lb (150kg) or the weight allowed by the lowest rated piece of equipment in the fall arrest system.
- Ensure that you have read and understood the maximum force tables for each anchor point.
- This equipment must only be assembled, installed and used by persons who have been trained in its correct application and use.
- When using for fall protection, only use one fall arrest device with each pulley/sheave and make sure that working procedures prevent individual lifelines from crossing and becoming tangled.
- When using the product in conjunction with another manufacturer's fall protection products, ensure that you have read the instructions for use of those products to ensure their suitability and any restrictions for use. Only use approved brackets for the connection of winches and self-retracting lifelines.

- It is essential for safety that the product is withdrawn from use immediately and not be used again until confirmed in writing by a competent person should;
 1. Any doubt arises about its condition for safe use or;
 2. It has been used to arrest a fall
 3. It has been used for any other purpose, other than as a component of a personal fall protection system

IRATA [International Rope Access Trade Association]

This product is suitable for rope access and has been tested to 15kN (3300lb) static load as per test requirements of IRATA International Code of Practice (ICOP).

➤ Fall Protection Applications

Fall Protection/Confined Space Set Up | 1 User

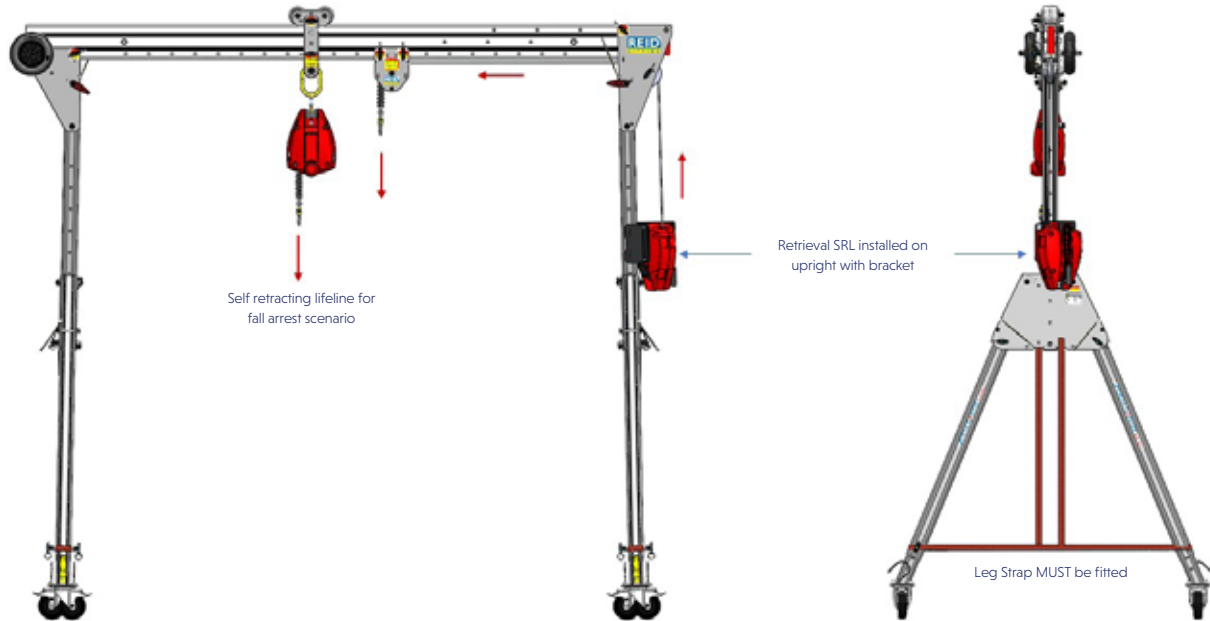

*Set up is indicative - Various winch brackets available.
Masterlink or Close Coupled trolley options available.

Fall Protection/Confined Space Set Up | 1 User

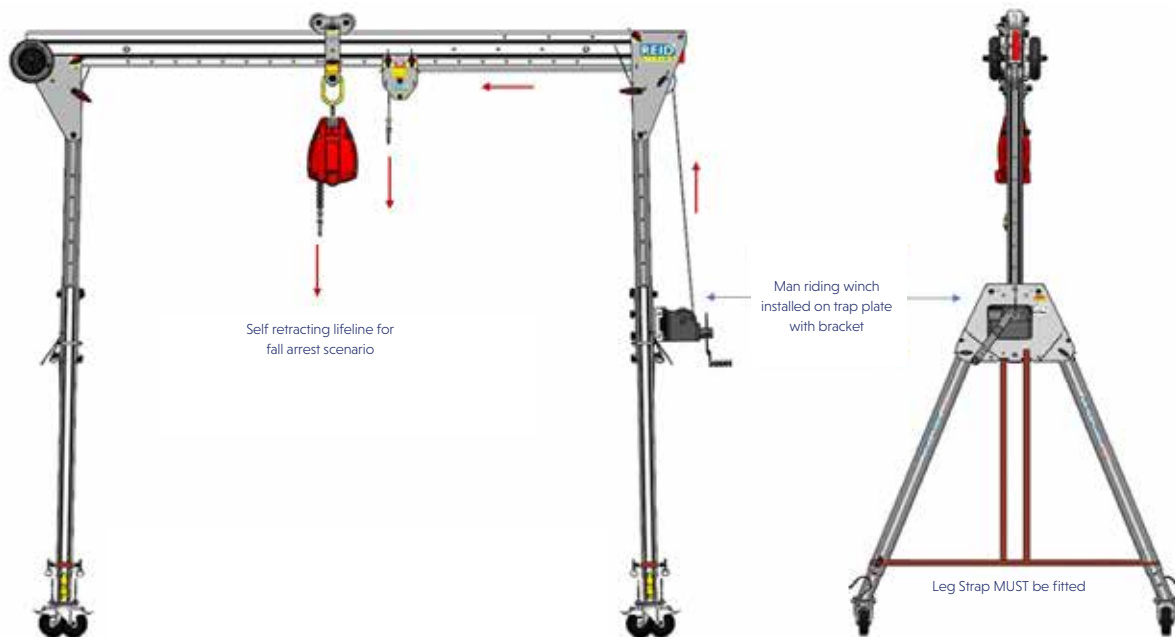

*Set up is indicative - Various winch brackets available.
Masterlink or Close Coupled trolley options available.

> Fall Protection Applications

Fall Protection/Confined Space Set Up | 2 Users [PGR2200lb Only]

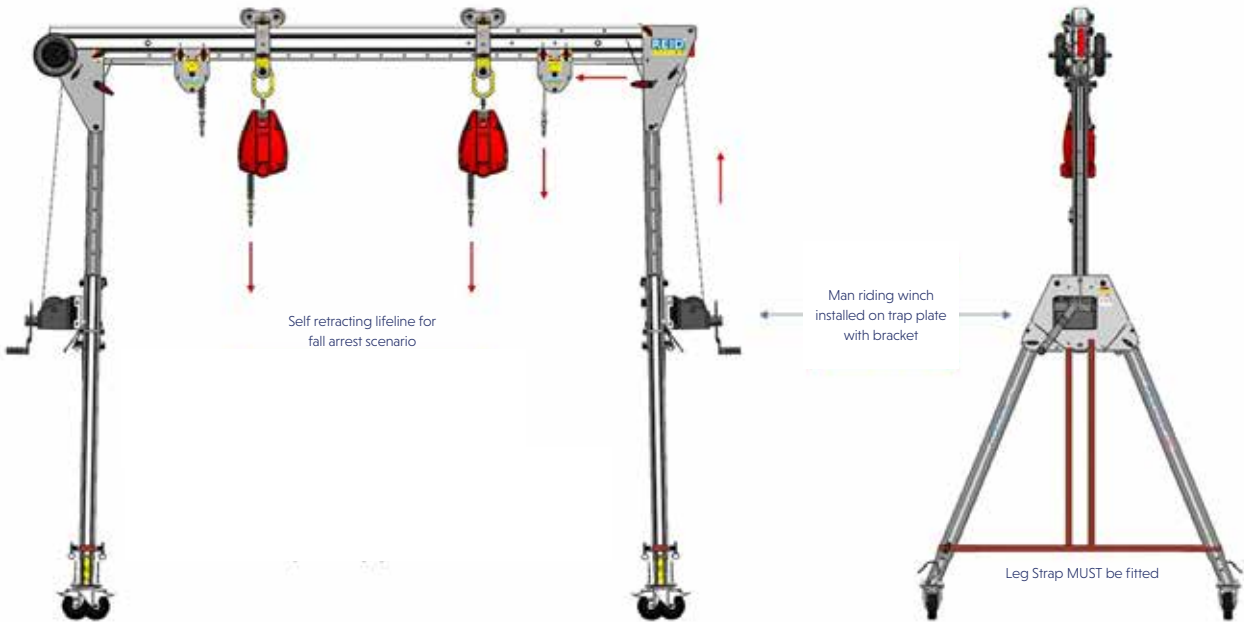

*Set up is indicative - Various winch brackets available.
Masterlink or Close Coupled trolley options available.

Fall Protection Set Up | 2 Users [PGR2200lb Only]

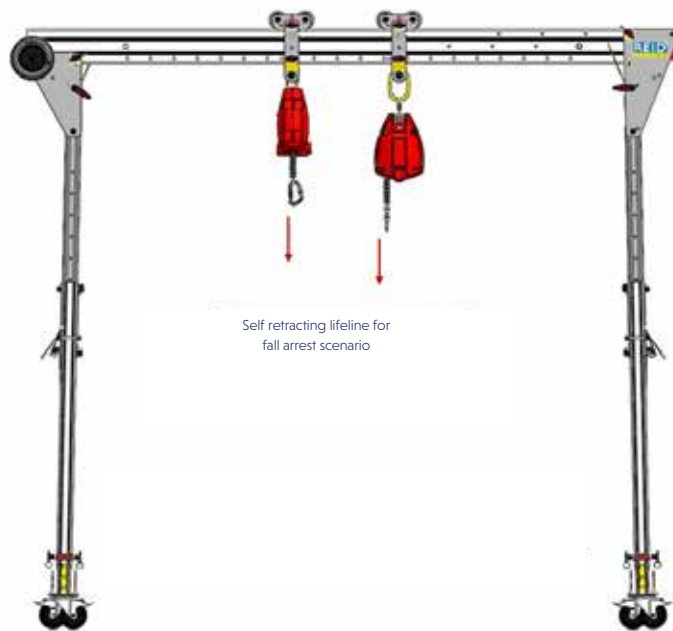

Self retracting lifeline for
fall arrest scenario



Leg Strap **MUST** be fitted

*Set up is indicative - Various winch brackets available.
Masterlink or Close Coupled trolley options available.

➤ Fall Protection Applications

PORTAGANTRY [RAPIDE] 1100lb | Fall Protection Anchor Ratings

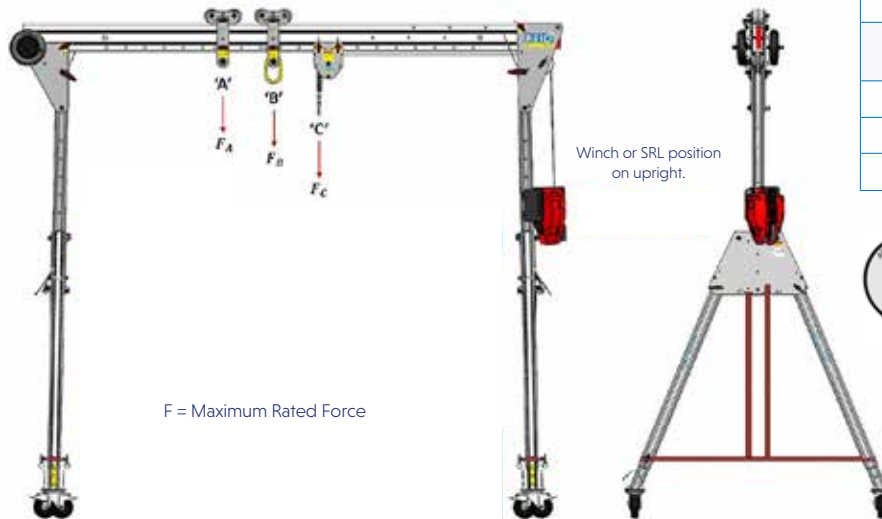

F = Maximum Rated Force

* Set up is indicative

PGR 500			
Product Code	Anchor Point 'A'	Anchor Point 'B'	Anchor Point 'C'
US-PGRS20J	22.2 kN [5000lb]	22.2 kN [5000lb]	22.2 kN [5000lb]
US-PGRS40J	15 kN [3300lb]	15 kN [3300lb]	15 kN [3300lb]
US-PGRT40J	15 kN [3300lb]	15 kN [3300lb]	12 kN [2700lb]



Where Maximum Rated Force is 22.2 kN [5000lb] the product is tested and meets the requirements of ANSI Z359.18 for 1 user. Where Maximum Rated Force is less than 22.2kN [5000lb] OSHA Regulations apply - minimum safety factor of 2:1. All trolleys and sheave carriers are ANSI Z359.18 rated for one user.

PORTAGANTRY **RAPIDE** 1100lb | Fall Protection Anchor Ratings

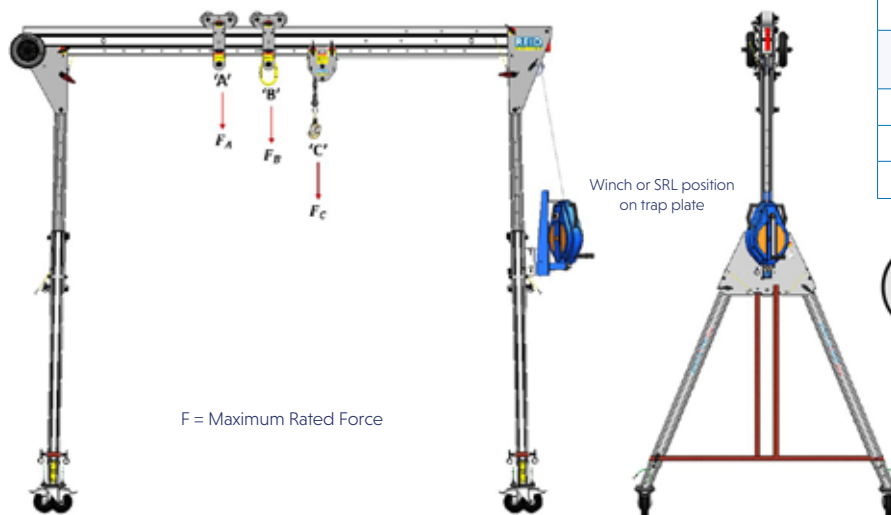

PGR 500			
Product Code	Anchor Point 'A'	Anchor Point 'B'	Anchor Point 'C'
US-PGRS20J	22.2 kN [5000lb]	22.2 kN [5000lb]	22.2 kN [5000lb]
US-PGRS40J	15 kN [3300lb]	15 kN [3300lb]	15 kN [3300lb]
US-PGRT40J	15 kN [3300lb]	15 kN [3300lb]	12 kN [2700lb]



Where Maximum Rated Force is 22.2 kN [5000lb] the product is tested and meets the requirements of ANSI Z359.18 for 1 user. Where Maximum Rated Force is less than 22.2kN [5000lb] OSHA Regulations apply - minimum safety factor of 2:1. All trolleys and sheave carriers are ANSI Z359.18 rated for one user.

* Set up is indicative



➤ Fall Protection Applications

PORTAGANTRY [RAPIDE] 2200lb | Fall Protection Anchor Ratings

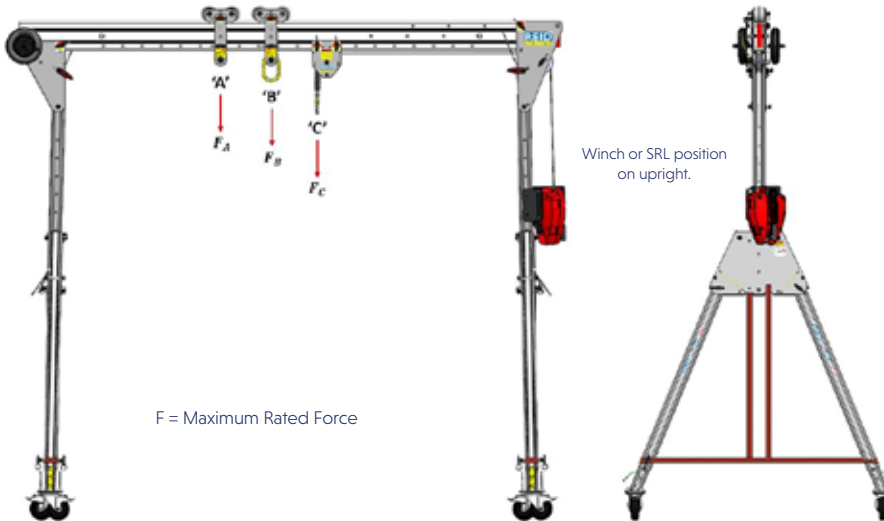

F = Maximum Rated Force

* Set up is indicative

PGR 1T			
Product Code	Anchor Point 'A'	Anchor Point 'B'	Anchor Point 'C'
US-PGR1TS20J	33.3 kN [7500lb]	33.3 kN [7500lb]	22.2 kN [5000lb]
US-PGR1TS30J	33.3 kN [7500lb]	33.3 kN [7500lb]	22.2 kN [5000lb]
US-PGR1TM30J	33.3 kN [7500lb]	33.3 kN [7500lb]	22.2 kN [5000lb]
US-PGR1TT30J	22.2 kN [5000lb]	22.2 kN [5000lb]	22.2 kN [5000lb]
US-PGR1TS40J	22.2 kN [5000lb]	22.2 kN [5000lb]	22.2 kN [5000lb]
US-PGR1TM40J	22.2 kN [5000lb]	22.2 kN [5000lb]	22.2 kN [5000lb]
US-PGR1TT40J	22.2 kN [5000lb]	22.2 kN [5000lb]	22.2 kN [5000lb]



Where Maximum Rated Force is 22.2 kN [5000lb] the product is tested and meets the requirements of ANSI Z359.18 for 1 user. Where Maximum Rated Force is 33.3 kN [7500lb] the product is tested to and meets the requirements of ANSI Z359.18 for 2 users. If more than 2 persons are required to be tied off, then OSHA Regulations apply - minimum safety factor of 2:1. All trolleys and sheave carriers are ANSI



PORTAGANTRY **RAPIDE** 2200lb | Fall Protection Anchor Ratings

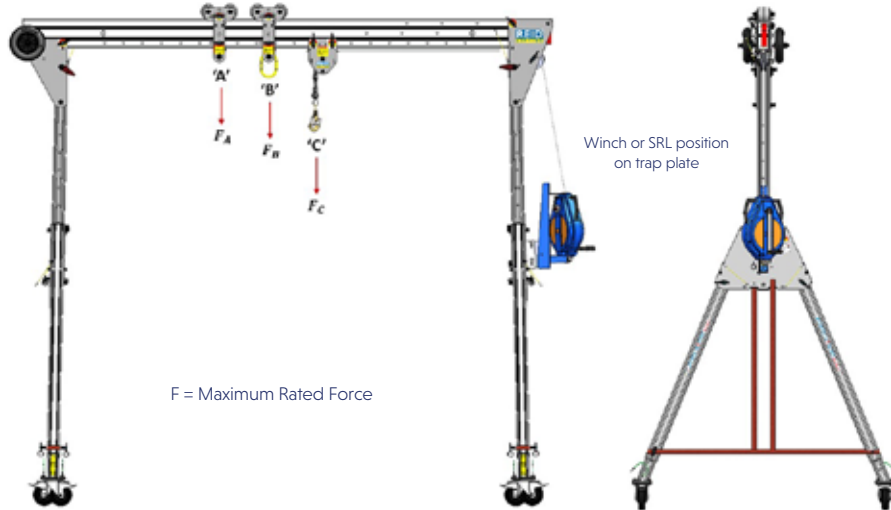

F = Maximum Rated Force

PGR 1T			
Product Code	Anchor Point 'A'	Anchor Point 'B'	Anchor Point 'C'
US-PGR1TS20J	33.3 kN [7500lb]	33.3 kN [7500lb]	22.2 kN [5000lb]
US-PGR1TS30J	33.3 kN [7500lb]	33.3 kN [7500lb]	22.2 kN [5000lb]
US-PGR1TM30J	33.3 kN [7500lb]	33.3 kN [7500lb]	22.2 kN [5000lb]
US-PGR1TT30J	22.2 kN [5000lb]	22.2 kN [5000lb]	22.2 kN [5000lb]
US-PGR1TS40J	22.2 kN [5000lb]	22.2 kN [5000lb]	22.2 kN [5000lb]
US-PGR1TM40J	22.2 kN [5000lb]	22.2 kN [5000lb]	22.2 kN [5000lb]
US-PGR1TT40J	22.2 kN [5000lb]	22.2 kN [5000lb]	22.2 kN [5000lb]



Where Maximum Rated Force is 22.2 kN [5000lb] the product is tested and meets the requirements of ANSI Z359.18 for 1 user. Where Maximum Rated Force is 33.3 kN [7500lb] the product is tested to and meets the requirements of ANSI Z359.18 for 2 users. If more than 2 persons are required to be tied off, then OSHA Regulations apply - minimum safety factor of 2:1. All trolleys and sheave carriers are ANSI

* Set up is indicative

➤ Inspection & Maintenance

The following information is based on REID Lifting's recommendations and does not remove the responsibility of the user to comply with the relevant regulations and standards that are valid in the respective countries and regions where the system is being used.

Regular Inspections

To ensure that the product's frame remains in safe working order it must be inspected regularly by a competent or qualified person. We recommend inspections every 6 months for personnel lifting and every 12 months for goods only, unless local regulations, adverse working conditions or profile of use and risk dictate shorter periods. The components of the system need to be checked for damage, wear, corrosion or other irregularities. It may be necessary to disassemble the system in order to do this. Particular attention should be paid to checking the profiles for denting, pins and fixings for integrity, making sure there is no wear or elongation on the bolt holes and ensuring that the trolley moves freely along the beam.

It is recommended that once inspected or repaired, the device is marked with the date of the next inspection.

Inspections are instigated by the user. If detailed information is required on inspection and test criteria, please contact your supplier's technical

department or REID Lifting. The equipment Inspection Record is on page 39.

If using the product in explosive atmospheres, see additional section titled ATEX.

Maintenance & Repair

In order to ensure correct operation, the conditions for inspection and maintenance must be complied with. If any defects are found, stop using the product immediately.

No alterations or additions to the equipment beyond the replacement of standard parts by an authorised representative should be made without the written consent of the manufacturer. Any necessary repairs identified during inspections should only be carried out by an approved specialist workshop using original spare parts. Any repair must be carried out in accordance with the manufacturer's instructions.

It is recommended to maintain the equipment in a clean and dry manner. Cleaning is suggested using a sponge or cloth with warm, soapy water, rinsing and allowing to dry.

This product must be assembled using metric fixings of the same type and quality as those supplied by the original manufacturer only. Failure to do so could have an impact on the structural performance and stability of the product. REID Lifting and its resellers can supply these spare parts locally.

Storage & Transportation

When transporting the components, take note of all the manual handling considerations.

Do not throw the product down or stack any items on top of it.

Always place carefully and securely on the ground to avoid damaging the equipment.

ATEX

This product has been designed for use in explosive atmospheres in line with the following requirements and information. Any use which differs or exceeds this is considered incorrect and REID Lifting will not accept any responsibility or liability for damages resulting from false application. The risk is solely with the user. If the product has been customized in any way, then it may not comply with standards and no longer be suitable for use in explosive atmospheres. If this is the case, then the product will not have any of the markings below. If in doubt, please contact your REID representative.

Classification [Zone 2]

As standard, the product meets the requirements of Category 3 equipment for use in Zone 2 explosive atmospheres, providing a normal level of protection where mixtures of air and gases, vapours or mists or by air and dusts mixtures are unlikely to occur or, if they do occur, are likely to do so only infrequently and for a short period only.

The product will have the following identification on the serial label:

As Standard for Zone 2 Environments:

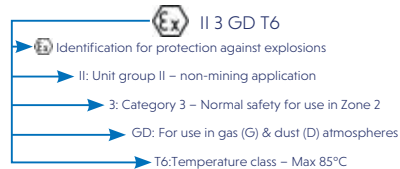

Classification [Zone 1]

Available as an upgrade, the product can be supplied to meet the requirements of Category 2 equipment for use in Zone 1 explosive atmospheres, providing a high level of protection where mixtures of air and gases, vapours, mists or by air and dusts mixtures are likely to occur.

The product will have the following identification on the serial label:

As an upgrade for use in Zone 1 environments:

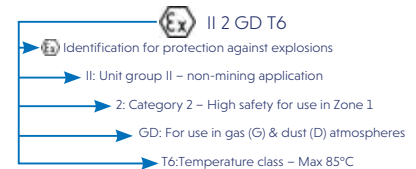

Spark Formation

There is an increased danger of ignition when certain material pairings clash, namely non-corrosion-resistant steel or cast iron against aluminum, magnesium or pertinent alloys. This applies especially in the case of rust or surface rust. When assembling the product and inserting fastening components, these must therefore be clear of rust and debris of any kind. As stated previously, care must be taken to ensure the gantry is handled in a suitable manner, never thrown down and always placed carefully onto the ground.

- ▶ For Zone 1 and 2 applications, the height of the system should not be adjusted using the ratchet mechanism and/or geared wheel within those zones.
- ▶ REID recommends the use of corrosion resistant tools when assembling the system to prevent the possibility of any sparks.
- ▶ For ATEX Zone 1 use, stainless steel castor brackets are fitted to reduce the possibility of a spark.

Static Electricity

For Zone 2 applications, there is a potential risk of static electricity build-up leading to an incentive spark. Although the risk of such ignition is unlikely, the system must be earthed during assembly and use. This can be achieved by attaching an earthing lead to a convenient location on metallic parts of both the system and trolley.

For additional protection in Zone 1 applications, the system is fitted with anti-static trolley rollers, stainless steel fasteners and therefore does not need to be earthed.

However, the effectiveness of the conductivity during operation can be affected by a dirty tread or other environmental influences and therefore must be checked periodically by the operator.

Inspection, Maintenance & Repair

Special attention should be given to dust deposits on the structure, especially in areas where the profiles come into contact, and should be wiped clean and care taken not to apply materials that could create electrostatic charging. Additionally, the bearings in the trolley rollers and castors should be checked to ensure they rotate freely.

The structure is predominantly constructed from aluminum which will not rust. However, there are steel components used throughout. These are; fasteners, castors, master-link, trolley rollers, A-Frame height adjustment gearing system (if fitted) and the height adjustment ratchet (if fitted).

Where there is sign of any rust deposits on the aluminum structure, it should be wiped clean as above and, where there is sign of rust on a steel component, that component should be removed from use and the structure not used until a replacement is fitted.

If using the product in explosive atmospheres, in addition to the Regular Inspection and Maintenance information above, these additional instructions should be followed:

- ▶ Inspections must be instigated by the user prior to each use if used in a potentially explosive atmosphere.
- ▶ Inspections and maintenance must be carried out at a safe distance away from an explosive atmosphere.

➤ Assembly Instructions

The PORTA GANTRY RAPIDE and its constituent components are described in the image below.

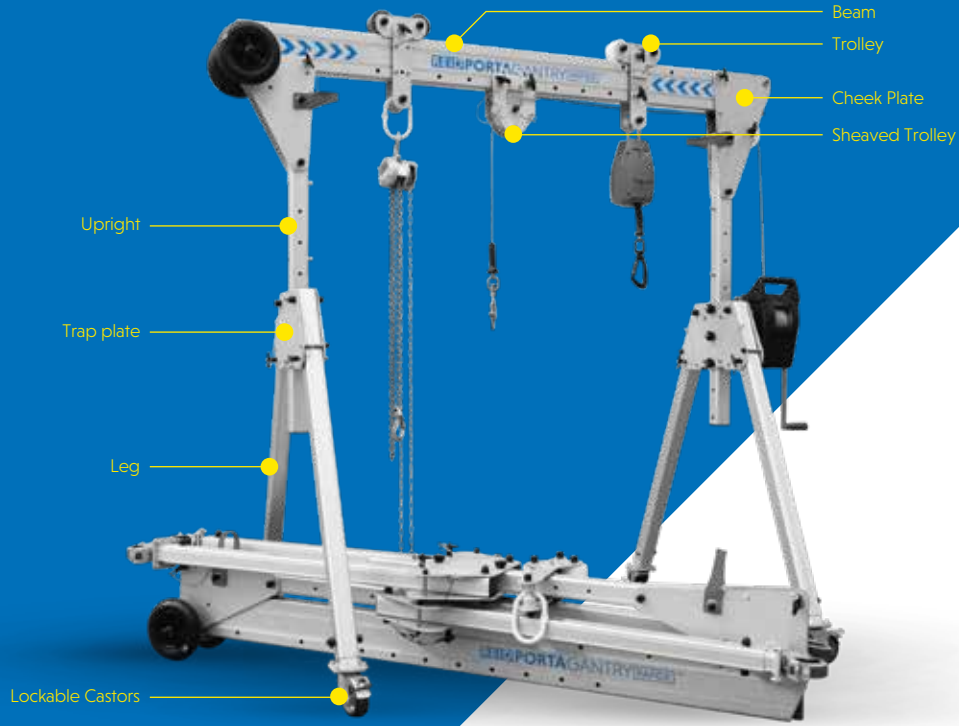

Appropriate PPE should be worn: ➤ Gloves ➤ Protective Footwear ➤ Hard Hat

Pre-Assembly

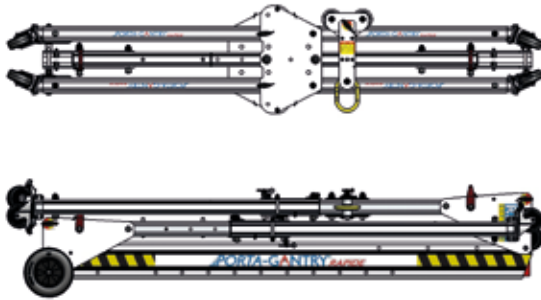

Pre set-up checks

- > PORTA GANTRY RAPIDE system delivered flat packed
- > Ensure castors are locked
- > Allow sufficient clearance for gantry frame rotation. If sufficient space not available see steps 23 to 27 - Confined Space Set-up method

N.B. Trolley can be stored separately, on the upper Upright or the Leg.

Standard Assembly



Rotate upper A-Frame to a vertical position.

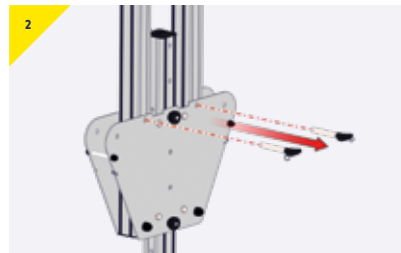

While in this vertical position remove ball lock pin from its stow hole on the Trap Plate.



Open leg and insert ball-lock pin into second hole securing the leg in its open position. Repeat for second leg on the same A-Frame.

> Assembly Instructions



- > Continue rotation of A-Frame until it comes to rest on ground



- > Repeat steps 1-4 for lower A-Frame



- > Scissor upper A-Frame until ball-lock pin is adjacent to beam
- > Remove ball-lock pin and continue scissor motion until stops engage beam and holes are aligned



- > Re-insert ball-lock pin into hole ensuring the pin is fully engaged through hole. A gentle rocking motion can be used to induce alignment



If fitted, ensure castor brakes applied before lifting a load.

- > Repeat steps 6 and 7 for opposite A-Frame

Master-link / Close-Coupled Trolley Installation

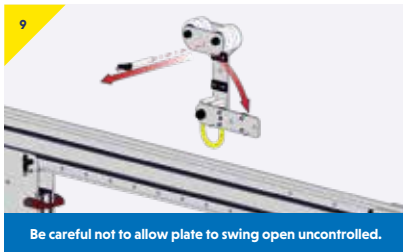

- Remove pin
- Open trolley and present to beam with plate rotated through 90°

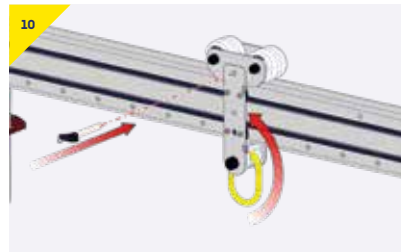

- Close trolley plate encapsulating the beam and re-insert ball-lock pin
- Ensure pin is properly engaged through holes
- If trolleys are required to be locked into position then an additional pin is available to provide trolley lock-off

Foot Adjustment



- To increase height pull foot down until desired position is achieved

Height Adjustment

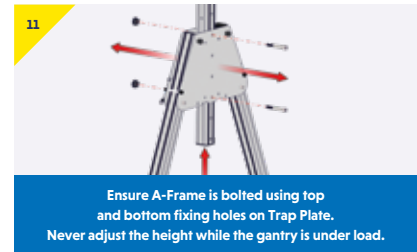

- Take weight of gantry upright
- Remove bolts and adjust to the desired height
- Re-insert bolts and hand tighten quick release knobs ensuring the gantry is secure

Pre-lift checks

- Ensure all ball lock pins are fully engaged into their respective holes
- Ensure all quick release knob/bolts on trap
- Plates and beam are hand tight and secure
- Ensure upright is bolted using top and bottom fixing holes on trap plate
- Ensure gantry is level

> Assembly Instructions

The following instructions are for the assembly of the Leg Strap.

Notes for Correct Operation:

- > The Leg Strap **MUST** be attached for the product to be used as an ANSI Z359.18 compliant system or an OSHA compliant fall protection anchor.
- > Ensure the pins are fully engaged through both of the Leg Strap eyelets.

Leg Strap Assembly

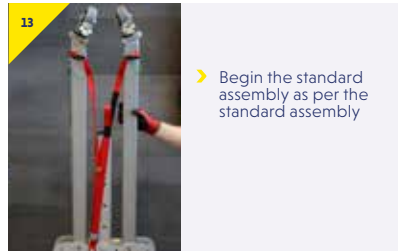

- > When the A-Frame is in the vertical position begin the assembly of the Leg Strap



- > Detach the Leg Strap from the velcro storage position.



- > Loosen the Leg Strap by pulling the buckle.



- > Ensure the Leg Strap is fully loosend.

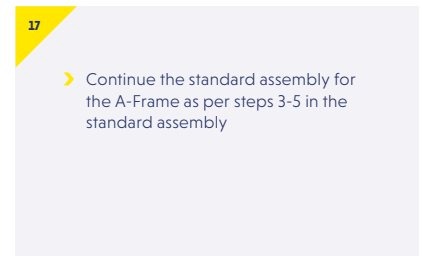

18

- › Repeat the process for the second Leg Strap on the lower A-Frame.

19



- › Continue the standard assembly for the A-Frame as per steps 6-8 in the standard assembly

Foot Adjustment

20



- › Foot adjustment is completed as per step 12 in the Assembly & Operation Guide.

N.B. Ensure the pin is fully inserted and is retaining both eyelets of the Leg Strap.

Leg Strap Stowage

21



- › For Leg Strap stowage tighten the Leg Strap using the buckle.

22



- › Reattach the Leg Strap to the velcro storage position.

➤ Assembly Instructions

Confined Space Assembly



- Rotate upper A-Frame to vertical position

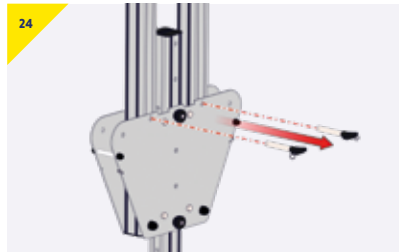

- While in this vertical position remove ball lock pin from its stow hole



- Open leg and insert ball-lock pin into second hole securing the leg in its open position.
- Repeat for second leg



Be careful not to trap hands between beam and cheek plates!

- Rotate upper A-Frame around until ball-lock pin is adjacent to beam
- Remove pin and continue motion, follow steps 6 and 7



If fitted, ensure castor brakes applied before lifting a load.

- Repeat steps 23 to 26 for lower A-Frame

Pre-lift checks

- Ensure all ball lock pins are fully engaged into their respective holes
- Ensure all quick release knob/bolts on trap
- Plates and beam are hand tight and secure
- Ensure upright is bolted using top and bottom fixing holes on trap plate
- Ensure gantry is level

Gantry Stowage

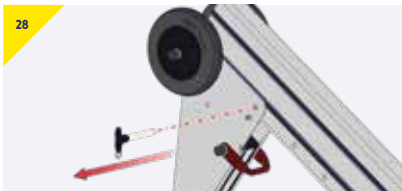

When folding gantry ensure ball-lock pins are stowed in cheek plate holes to avoid damage.

- To fold the gantry reverse steps 10 to 1 for Standard Assembly or steps 27 to 23 for Confined Space Assembly

Trolley Storing

- Trolley can be stored separately, on the upper A-Frame or the leg

Winch Bracket Installation

Never install winch bracket while gantry is under load. Only install winches which are approved by REID for use with the PORTA GANTRY RAPIDE and a suitable interface / mounting plate supplied.

Winch can be installed on both sides of gantry and on either bolts A and B or B and C (PGR250-500) OR A and B, B and C or A and D (PGR1000). Ensure winch bracket and quick release knobs are hand tight.

PGR

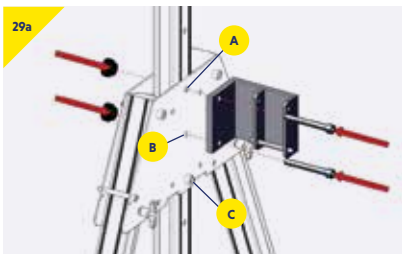

- Remove existing bolt, A or C
- Present bracket to gantry as shown (with locating pin at bottom) and insert new, longer bolts securing the winch with the quick release knobs provided

PGR 2200lb

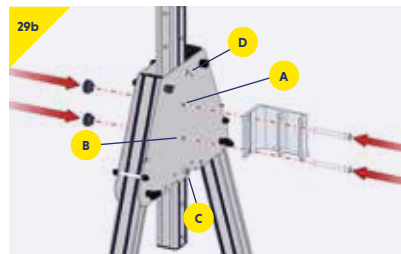

> Assembly Instructions

Winch Installation

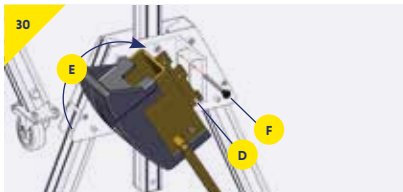

Illustration shows one example of many winches, fall arrests and interface brackets available.

- > Place winch onto locating pin, D
- > Rotate winch to align holes, E

30a

- > Place retaining pin into holes, F
- > Observe pin is securely engaged

Fall Arrest Block Installation

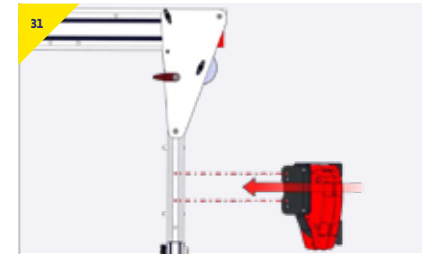

- > Present the fall arrest block to the Upright as shown and ensure it is aligned with the holes

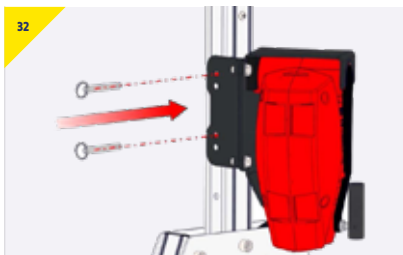

- > Insert the retaining pins to secure in place on the Upright

Sheave Trolley Installation

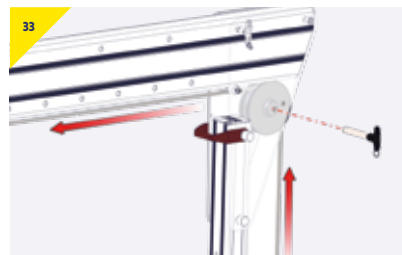

- > Thread rope through cheek plates and capture rope between sheave and beam
- > Secure sheave with ball-lock pin
- > Observe pin is securely engaged



- > Present sheaved trolley to underside of beam
- > Capture rope between sheaved trolley and beam and insert pin as shown

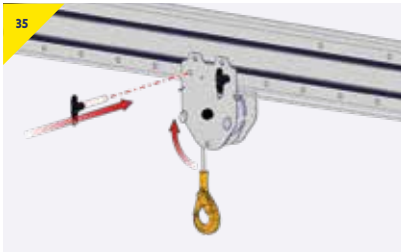

- Insert second pin as shown
- Observe both pins are fully engaged

Beam Width Adjustment

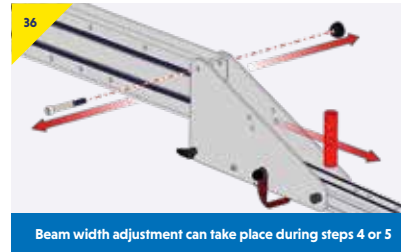

Beam width adjustment can take place during steps 4 or 5

- Remove bolt and handle
- Store handle in safe place



- Move A-Frame assembly to required position
- Re-insert bolt and hand tighten quick release knob
- Complete assembly of gantry as steps 6-8

Changing the Foot Option



- The foot option can be changed by removing the ball lock pin and withdrawing the foot cartridge assembly

Adjustable Foot Option



- For coarse adjustment in leg height set cartridge at desired point (2x50mm increments)



Never adjust the height while the gantry is under load.

- For fine height adjustment depress lever and push foot up to desired position
- Observe gantry is level

> Dimensions

PORTAGANTRY RAPIDE™

- A** Beam length
- B** Beam adjustment
- C** Clear operating span
- D** Height to lifting eye
- E** Height increment
- F** Height to top of beam
- G** Width
- H** Height to top of roller
- J** Folded dimensions

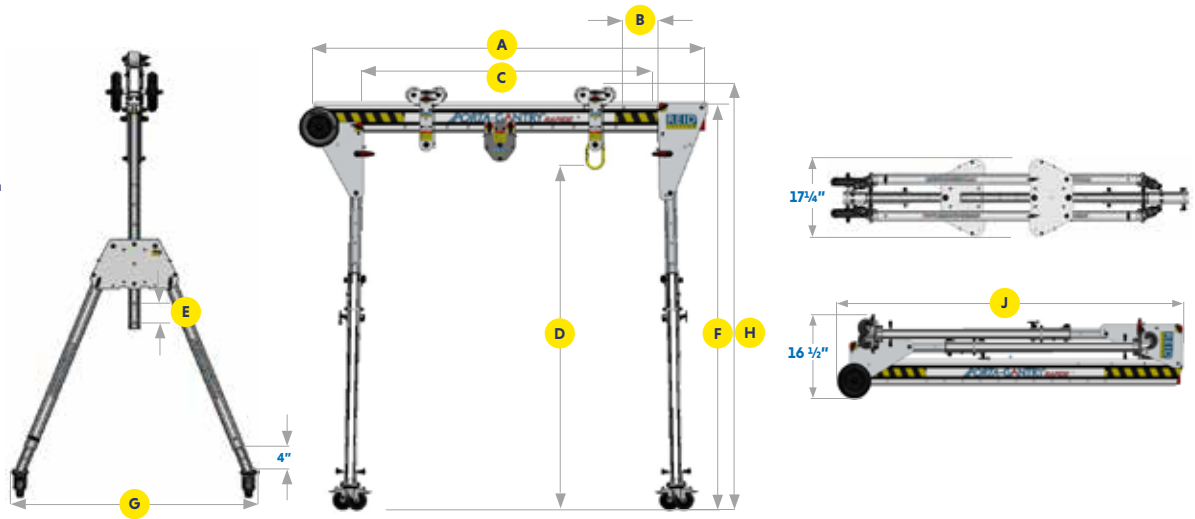

	Dimensions												
	A Beam Length	B	CMin	CMax	DMin	DMax	EMin	FMin	FMax	G	HMin	HMax	J
US-PGRS20	6' 6¾"	2 x 8"	3' 7¼"	4' 11"	4' 9"	6' 8¾"	6 x 4"	5' 10"	7' 9½"	3' 9½"	6' 1¼"	8' ¾"	6' 10"
US-PGRS23	7' 6½"	3 x 8"	3' 11¼"	5' 10¾"									7' 9¾"
US-PGRS40	13' 1½"	4 x 8"	8' 10¼"	11' 5¾"									13' 4½"
US-PGRM20	6' 6¾"	2 x 8"	3' 7¼"	4' 11"	4' 9¾"	7' ¾"	7 x 4"	5' 10"	8' 1¾"	3' 11¾"	6' 1¼"	8' 5"	6' 10"
US-PGRM23	7' 6½"	3 x 8"	3' 11¼"	5' 10¾"									7' 9¾"
US-PGRM40	13' 1½"	4 x 8"	8' 10¼"	11' 5¾"									13' 4½"
US-PGRT20*	6' 6¾"	2 x 8"	3' 7¼"	4' 11"	6' 4"	9' 7¼"	10 x 4"	7' 4¾"	10' 8"	5' 2½"	7' 8"	10' 11¼"	8' 8¾"
US-PGRT23*	7' 6½"	3 x 8"	3' 11¼"	5' 10¾"									7' 9¾"
US-PGRT40*	13' 1½"	4 x 8"	8' 10¼"	11' 5¾"									13' 4½"

*Trolley stops fitted to beam.

	Capacity		Unit Weight
	Goods Capacity (lb)	Personnel Positioning (lb)	(lb)
US-PGRS20	1100	550	73
US-PGRS23	880	440	77
US-PGRS40	550	275	88
US-PGRM20	880	440	77
US-PGRM23			79
US-PGRM40	550	275	90
US-PGRT20*			86
US-PGRT23*			88
US-PGRT40*			99

> Dimensions

PORTAGANTRY RAPIDE™ 22001b

- A** Beam length
- B** Beam adjustment
- C** Clear operating span
- D** Height to lifting eye
- E** Height increment
- F** Height to top of beam
- G** Width
- H** Height to top of roller
- J** Folded dimensions

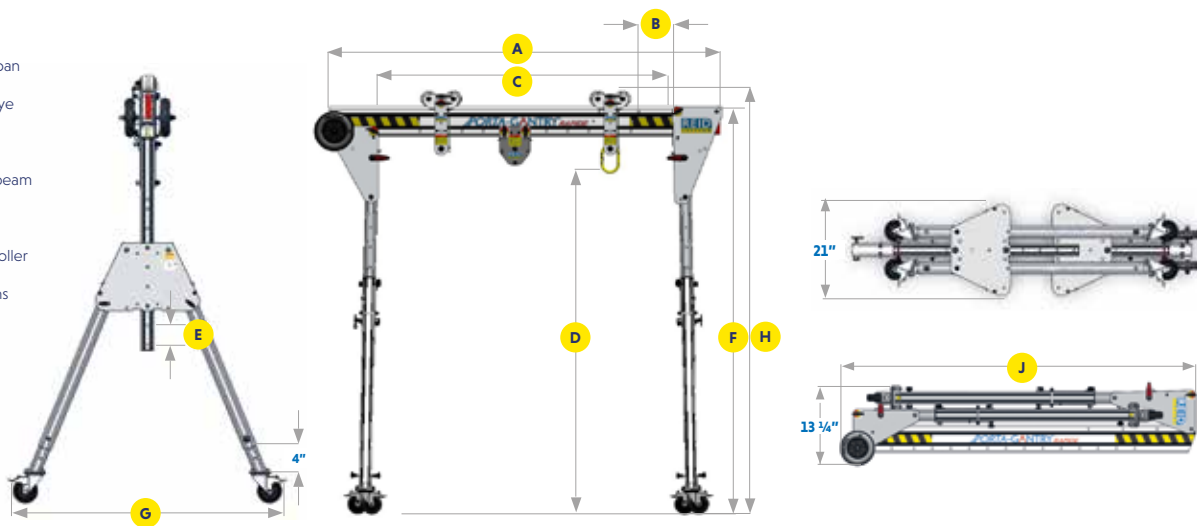

Dimensions													
	A Beam Length	B	CMin	CMax	DMin	DMax	E	FMin	FMax	G	HMin	HMax	J
US-PGRITS20	6' 6¾"	2 x 8"	3' 7½"	4' 11¼"	4' 8¼"	6' 4"	5 x 4"	5' 11¾"	7' 7½"	4' 2"	6' 3"	7' 10¾"	6' 9¾"
US-PGRITS30	9' 10"	3 x 8"	6' 2½"	8' 2½"									10' 1¼"
US-PGRITS40	13' 1½"	3 x 8"	9' 6¼"	11' 5¾"									13' 4½"
US-PGRITM20	6' 6¾"	2 x 8"	3' 7½"	4' 11¼"	5' 8½"	8' 0"	7 x 4"	6' 9¼"	9' ¾"	4' 10½"	7' ½"	9' 4"	7' 2½"
US-PGRITM30	9' 10"	3 x 8"	6' 2½"	8' 2½"									10' 1¼"
US-PGRITM40	13' 1½"	3 x 8"	9' 6¼"	11' 5¾"									13' 4½"
US-PGRITT20*	6' 6¾"	2 x 8"	1' 11½"	3' 5¾"	6' 6"	9' 5½"	9 x 4"	7' 6½"	10' 6"	5' 6¾"	7' 9¾"	10' 9¾"	9' 3½"
US-PGRITT30*	9' 10"	3 x 8"	4' 7½"	6' 7½"									10' 1¼"
US-PGRITT40*	13' 1½"	3 x 8"	7' 10"	9' 9½"									13' 4½"

*Trolley stops fitted to beam

	Capacity		Unit Weight
	Goods Capacity (lb)	Personnel Positioning (lb)	(lb)
US-PGRITS20	2200	1100	99
US-PGRITS30	2200	1100	117
US-PGRITS40	2200	1100	128
US-PGRITM20	2200	1100	108
US-PGRITM30	2200	1100	119
US-PGRITM40	2200	1100	130
US-PGRITT20*	2200	1100	117
US-PGRITT30*	2200	1100	128
US-PGRITT40*	2200	1100	137

› Quality & Safety

Regulations, Standards & Directives

This product complies with the following:

- › ANSI Z359.18-2017
- › In conformity with EN795:2012 and OSHA 1910 subpart I, OSHA 1910.66 Appendix C (I) and OSHA 1926.502 subpart M
- › The Lifting Operations and Lifting Equipment Regulations 1998 (S.I. 1998 No. 2307)
- › The Provision and Use of Work Equipment Regulations 1998 (S.I. 1998 No. 2306)
- › Machinery Directive 2006/42/EC
- › PPE Regulation (EU) 2016/425
- › ATEX Directive - 2014/34/EU*

*Powder coated sections removed

It is essential to adhere to the safety regulations of the respective country for using manual lifting equipment.

Accreditations

Quality and Safety are at the heart of the REID Lifting ethos and we are committed to maintaining the very highest standards. With this in mind, we have undertaken external accreditations to ensure we stay focused on what is important to our clients and users, and ahead of market trends and developments.

REID Lifting is continuously audited by Lloyds Register Quality Assurance (LRQA) for approval of its Integrated Management System combining quality systems management, environmental issues and the health and safety practices within the company.

- › ISO 9001:2015 - Quality management system which assesses an organization's ability to consistently provide products that meet customer and applicable regulatory requirements and aims to enhance customer satisfaction.
- › ISO 14001:2015 - Specifies the requirements for implementing environmental management systems throughout all areas of the organization.
- › ISO 45001 – Health & Safety Management System

- › LEEA Membership - REID Lifting is a full member of the Lifting Equipment Engineers Association (LEEA membership 000897). REID Lifting conforms to the main aims of the association which is to achieve the highest standards of quality and integrity in the operations of members. Entry qualifications are demanding and strictly enforced through technical audits based on the Technical Requirements for Members.
- › IRATA - REID Lifting is an associate member of the Industrial Rope Access Trade Association (IRATA International membership number 148). REID Lifting works in accordance with the IRATA Code of Practice and, in doing so, contributes to promote the development of safe systems.

Conformité Européenne [CE]

REID Lifting's products have been designed, tested and approved (as appropriate) by the Conformité Européenne. This certifies that REID Lifting's products meet the demands of the European Directives and Regulations regarding Health and Safety requirements. The EC type-examination for this device has been carried out by SGS United Kingdom Ltd, 202b, Worle Parkway, Weston-super-Mare, BS22 6WA, United Kingdom (CE body no.0120) in accordance with Module B of the PPE Regulation. The EC quality assurance system for this device has been carried out by SGS Fimko Oy, Takomotie 8, FI-00380 Helsinki, Finland. (CE body no. 0598) in accordance with Module D PPE Regulation (EU) 2016/425.

Testing

Testing and technical file review are integral parts of our design and manufacturing process. External verification of products is undertaken where appropriate, using government approved Notified Bodies.

All products have been thoroughly type tested. Each product is supplied with a certificate of conformance and individual record of thorough examination or test.

Language

It is essential for the safety of the user that if this product is re-sold outside of the original country of destination, the reseller shall provide instructions for use, maintenance, inspection and repair in the language of the country where it will be used.

Product IPR

Intellectual property rights apply to all REID Lifting Ltd products. There are patents in place, or pending, for:

PORTAGANTRY[™] | **PORTAGANTRY[®] RAPIDE[™]** | **PORTADAVIT[®] QUANTUM[™]** | **TDAVIT[™]**

All product names are trademarks of REID Lifting Ltd:

PORTAGANTRY[™] | **PORTAGANTRY[®] RAPIDE[™]** | **PORTADAVIT[™]** | **PORTABASE[™]** | **TDAVIT[™]** | **PORTAQUAD[™]**



Insert data from serial numbers found on product into table here:

Marking

The serial labels indicate:

- The product identification number
- The product's unique serial number
- The goods' capacity (WLL) of the device
- The year of manufacture
- The standards to which the device is approved
- The ATEX rating of the product (if applicable)
- CE Marking
- Minimum braking load (MBL)

Periodic Examination & Repair History

Date	Inspected by	Pass/Fail	Comments

Contact Us

REID Lifting Inc, USA

7900 International Drive
Suite 300
Bloomington
MN 55425
United States of America

-  +1-(888)-721-6411
-  info@reidlifting.com
-  us.reidlifting.com

All information herein is copyright protected by REID Lifting Ltd. All company and product names are Trade Mark and Trade Name protected and all REID Lifting Ltd. Product IPR is protected under Patents, Patents Pending and/or Design Rights.

 Printed using environment friendly processes and materials.