

Clamps, Grabs & Tongs

Model GC - Girder Clamps



PRODUCT FEATURES:

- These clamps provide an efficient method for handling wide flange beam sections and plate girders.
- Screw-spindle design ensures positive grip.
- Simple design ensures minimum maintenance.
- Left-hand thread and right-hand thread screw spindle allows for rapid clamping and unclamping.
- Jaw opening adjusts to a wide range of beam types and flange widths.
- Use only for vertical lifting.
- Complies with ASME standards.

**INSTOCK
PROGRAM**

SPECIFICATIONS

Model Number	Rated Capacity (tons)	Dimensions (inches)							Weight (lbs.)
		Flange Width Min. - Max.	Max. Flange Thickness	A	B	C	D Min. - Max.	E Min. - Max.	
GC - 15	15	6 - 24	3	14.81	3.9	1.6	23 - 44	15.7 - 23.4	234
GC - 20	20	6 - 24	3	14.81	5	2.1	23 - 44	18.3 - 25.9	291
GC - 25	25	6 - 24	3	14.81	5	2.1	23 - 44	18.3 - 25.9	342

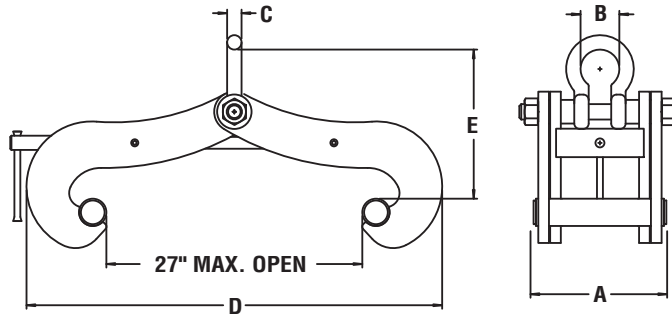

Operation



For lifting and positioning structural beams. Can be used in pairs in conjunction with a spreader beam for additional stability.

WARNING
Use only for vertical lifting.

