

- Forged steel – Quenched and Tempered.
- Used as a come-a-long for short take-up on chain.
- Binder toggles away from the load.
- Binders shown with Proof Loads have been individually proof tested to values shown, prior to shipment.
- Meets or exceeds requirements of US DOT FMCSA Part 393 Subpart I.

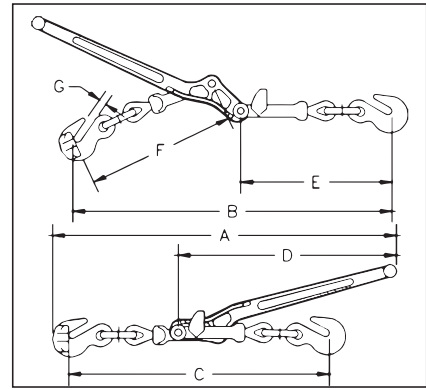

SEE APPLICATION AND WARNING INFORMATION
 On Pages 271
 Para Español: www.thecrosbygroup.com



A-1W Walking Load Binders

Model	Stock No.	Chain Size (in)	Working Load Limit (lb)	Proof Load (lb)	Ultimate Load (lb)	Weight Each (lb)	Handle Length (in)	Dimensions (in)						
								A	B	C	D	E	F	G
A-1W	1048388	1/2 only	9200	18400	33000	13.10	18.69	28.75	25.75	21.25	18.69	12.31	12.38	.63

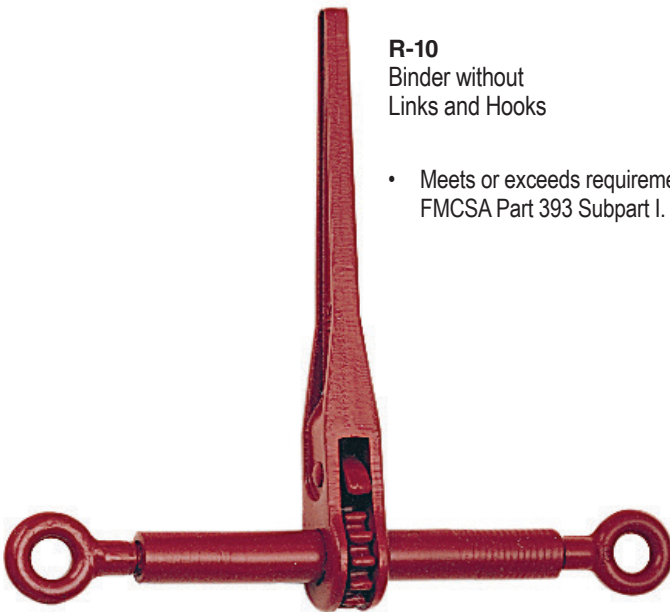

- Meets or exceeds requirements of US DOT FMCSA Part 393 Subpart I.

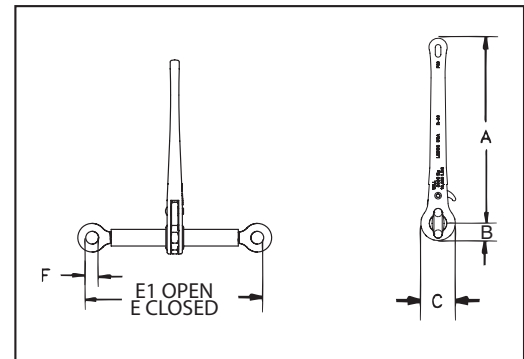

R-10 Binder without Links and Hooks

Model	R-10 Stock No.	Working Load Limit (lb)*	Weight Each (lb)	Handle Length (in)	Barrel Length (in)	Take Up (in)	Dimensions (in)					
							A	B	C	E	E1	F
R-10	1048468	16000	8.04	14	10	8.0	14	1.38	2.75	14	22	1.00

* Ultimate Load is 3 times the Working Load Limit.