

# Clamps, Grabs & Tongs



The Caldwell Group • 800-628-4263 • www.caldwellinc.com

Rig-Master® Section  
2014-2016 Master Catalog

## Model ALG - Adjustable Lifting Grab



**INSTOCK PROGRAM**

### PRODUCT FEATURES:

- Heavy-duty design to withstand rugged, high-cycle environments.
- Infinitely adjustable within range.
- Fully adjustable stainless steel Auto-Latch.
- Locating assembly orientates grab on load without operator intervention.
- Replaceable polyurethane pads protect load from lifter damage.
- Color-coded decal indicates the amount of travel remaining for each adjustment.
- Position indicating decals for easy adjustment.
- Extended handles keep operator away from load and can be adjusted as needed.
- Optional hardened alloy steel dog points available.
- Lifting eye allows for easy hook attachment, self-centers rigging, and will accommodate a fork.
- Designed and manufactured to ASME B30.20, BTH-1, service class 3.

### SPECIFICATIONS

Model Number	Capacity lbs.	A - Max. Width	C - Overall Width	Weight lbs.
ALG-3-3/24	6000	24"	72.5	600
ALG-3-3/42	6000	42"	90.5	650
ALG-3-3/60	6000	60"	108.5	700

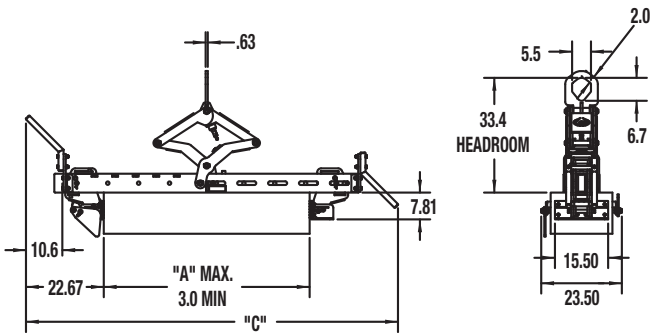

## Standard Configurations

6" Barriers



12" Barriers



Big Blocks

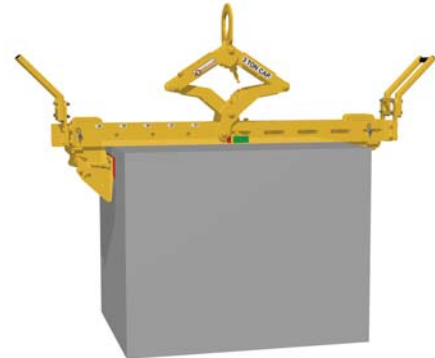

## Custom Configurations

One-Sided



Inside



Round



Ingot

