

**Tribesigns**

LITTLE TREE

# Assembly Instructions

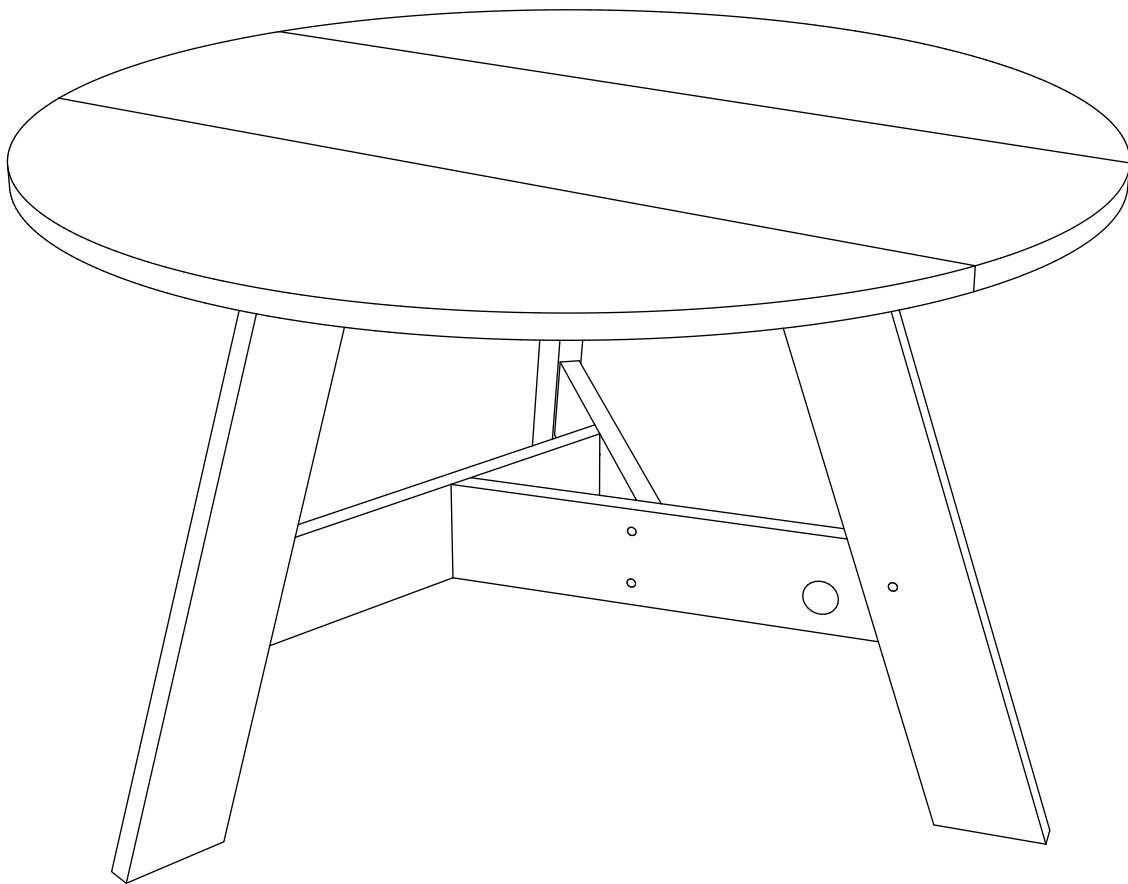

**Model No. J0296**

**Round dining table**

# Call us!

## We're here to help!

If you have any issues with this product, please contact our customer service team **before returning** it.



We want you to be completely satisfied with your purchase! If anything is missing, damaged, incor-rect, or not what you expected, don't worry. Please keep the outer packaging and take photos of both the packaging and products, and then reach out to us at support@tribesigns.com or call us at **1-424-220-6888**. We'll take care of everything and send you a free replacement, so you can enjoy your purchase as soon as possible without any hassle.

## Assembly Instructions:

1. Carefully read these instructions and keep them for future reference.
2. Refer to the parts list for guidance and ensure that you have all the pieces before starting the assembly process, if anything is missing, damaged, incorrect, contact us **FIRSTLY BEFORE** assembling.
3. When assembling, place all parts on a soft, clean, and flat surface, such as a carpet, to prevent any scratches.
4. To avoid misalignment of the holes, Please don't full tighten the screws until you ensure all parts in place.

---

## Follow Tribesign:



Facebook



Twitter



Pinterest



YouTube



Instagram

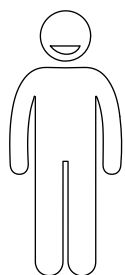

**X2**

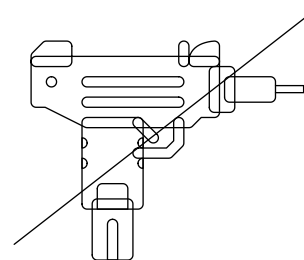
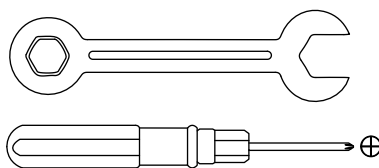

When using the electric screwdriver ,  
Reduce the power and torque to avoid damaging the furniture

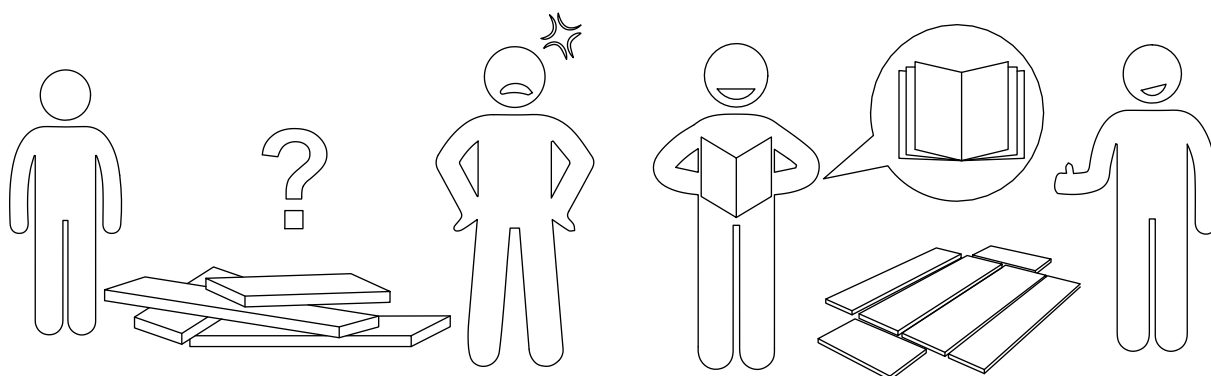

**Caution**

Do not sit or put pressure on one side of the table.

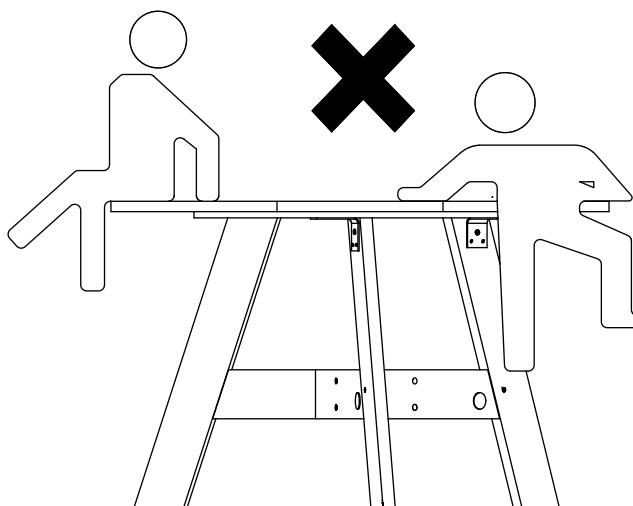

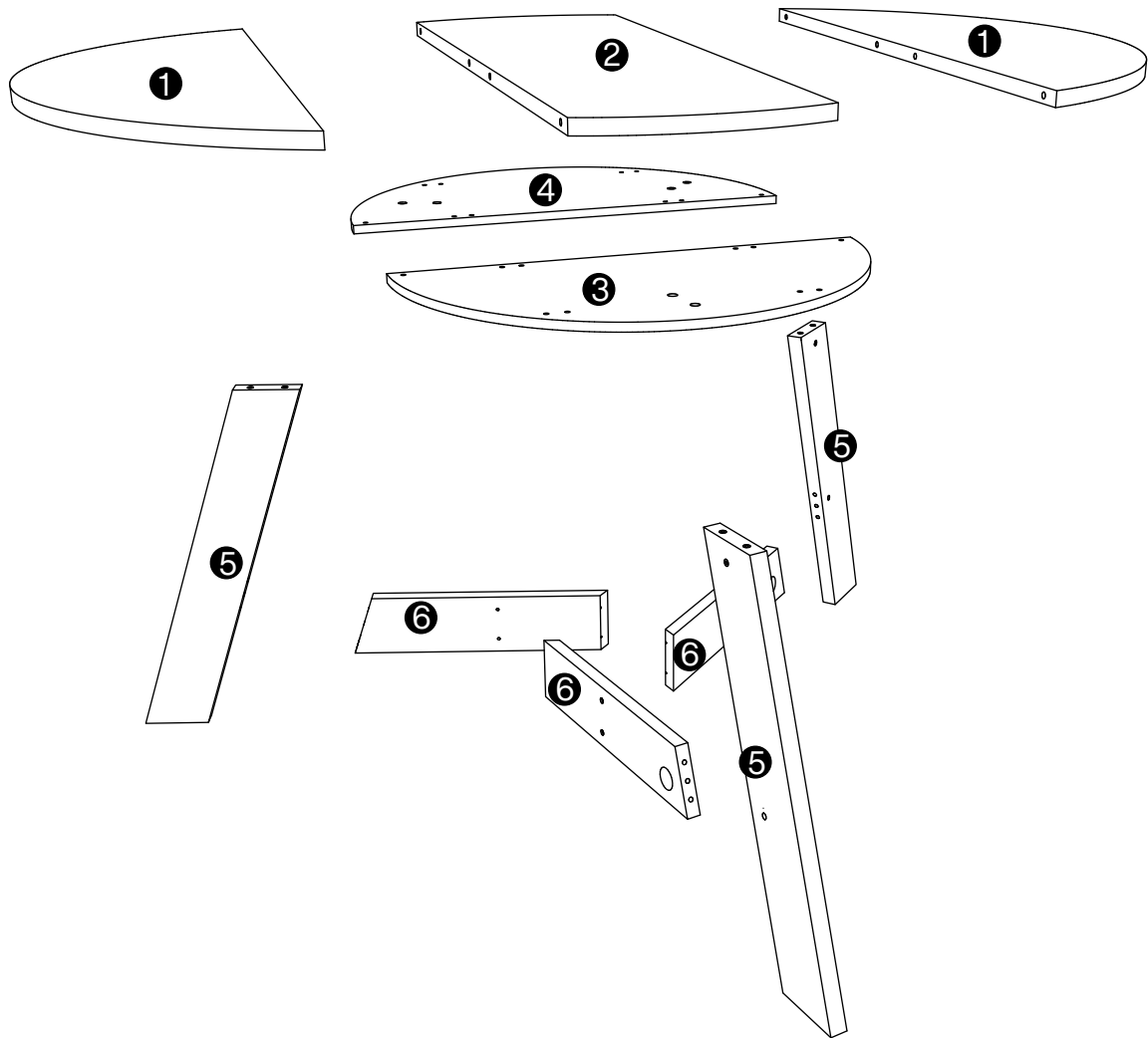

Make sure all parts are included. Most board parts are labeled or stamped on the raw edge. Contact us for free replacement if having damaged or missing parts.

## Parts & Hardware List

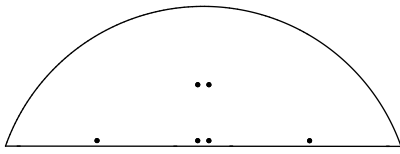

① 2pcs

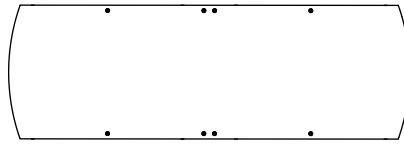

② 1pc

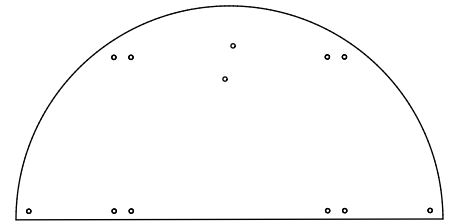

③ 1pc

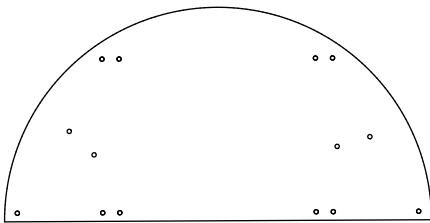

④ 1pc

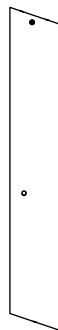

⑤ 3pcs

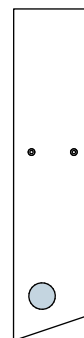

⑥ 3pcs

## Hardware List



M6\*25

Ⓐ

6pcs



M6\*30

Ⓑ

20pcs



φ8\*30

Ⓒ

6pcs



Ⓓ

6pcs



Ⓔ

1pc



Ⓕ

3pcs



Ⓖ

1pc



Ⓗ

3pcs



Ⓘ

3pcs



Ⓙ

3pcs



Ⓚ

3pcs



Ⓛ

3pcs



Ⓜ

9pcs

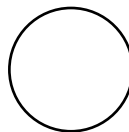

Ⓝ

3pcs



M6\*15

Ⓞ

3pcs



φ10\*40

Ⓟ

8pcs



Ⓠ

15pcs



Ⓡ

3pcs

## Installation of Cams and Pins

Screw the pin into the hole. To set the cams correctly, ensure that the arrow on the cam is opening to the hole of the pin it is locking. Lock the cam by turning the cam head with a screwdriver until it is tightened. Please do not use an electric screwdriver to assemble the unit.

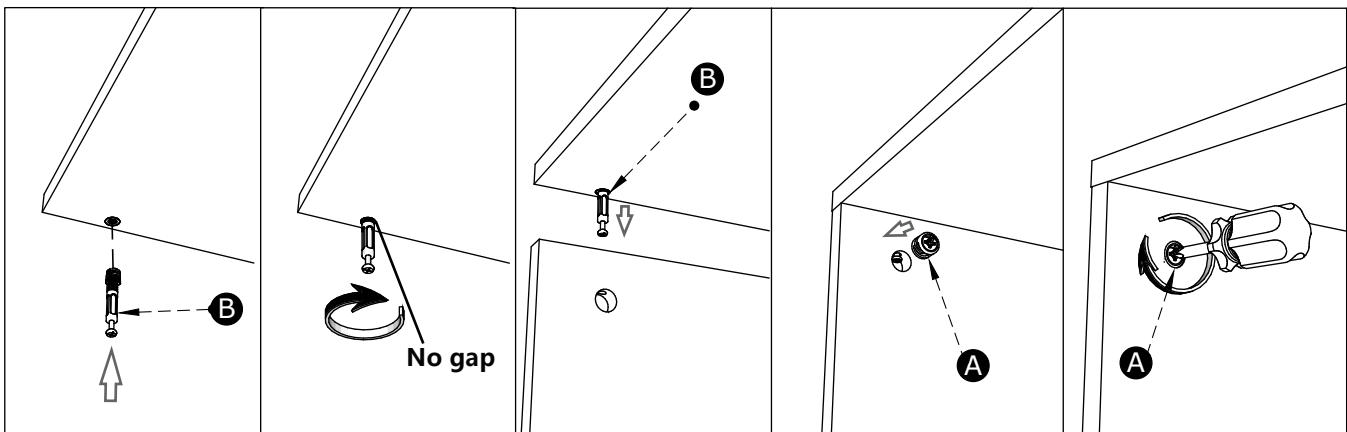
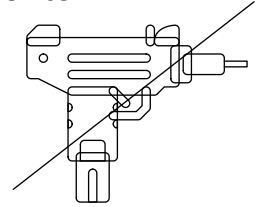

Read each step carefully before starting. It is very important that each step of instruction is performed in the correct order. If these steps are not followed in sequence, assembly difficulties will occur.

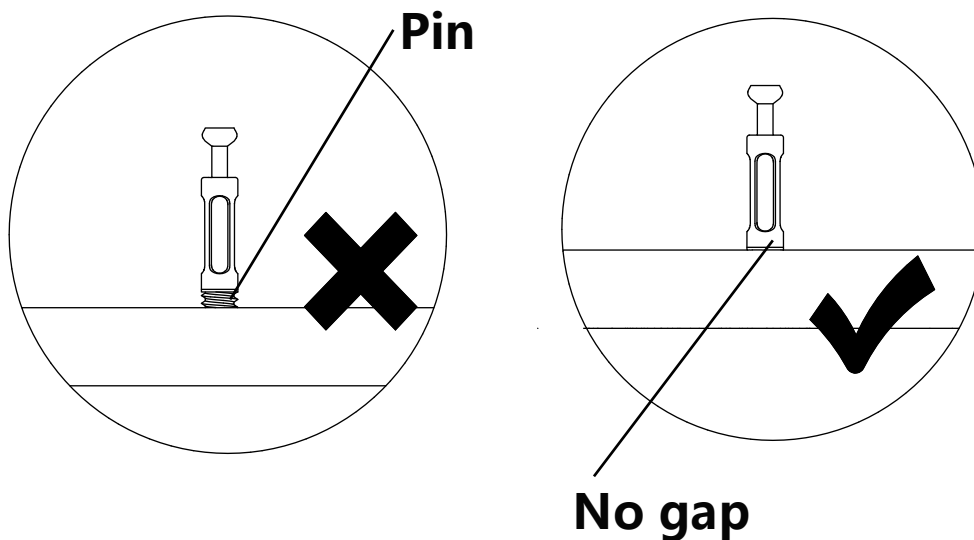

1

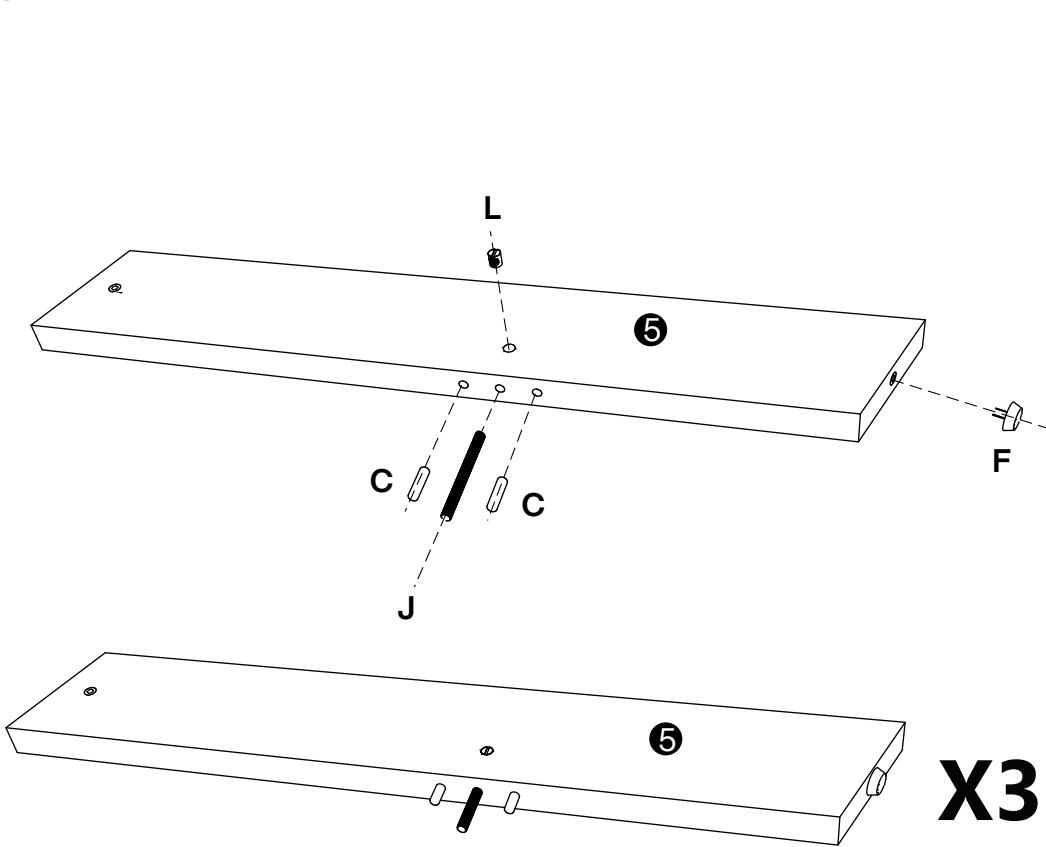

- $\phi 8 \times 30$
- 
- 
- 
- C** 6pcs
- J** 3pcs
- L** 3pcs
- F** 3pcs

**X3**

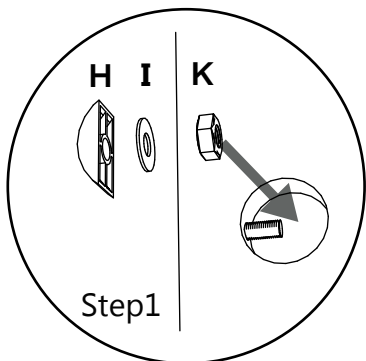

- 
- 
- 
- H** 3pcs
- I** 3pcs
- K** 3pcs

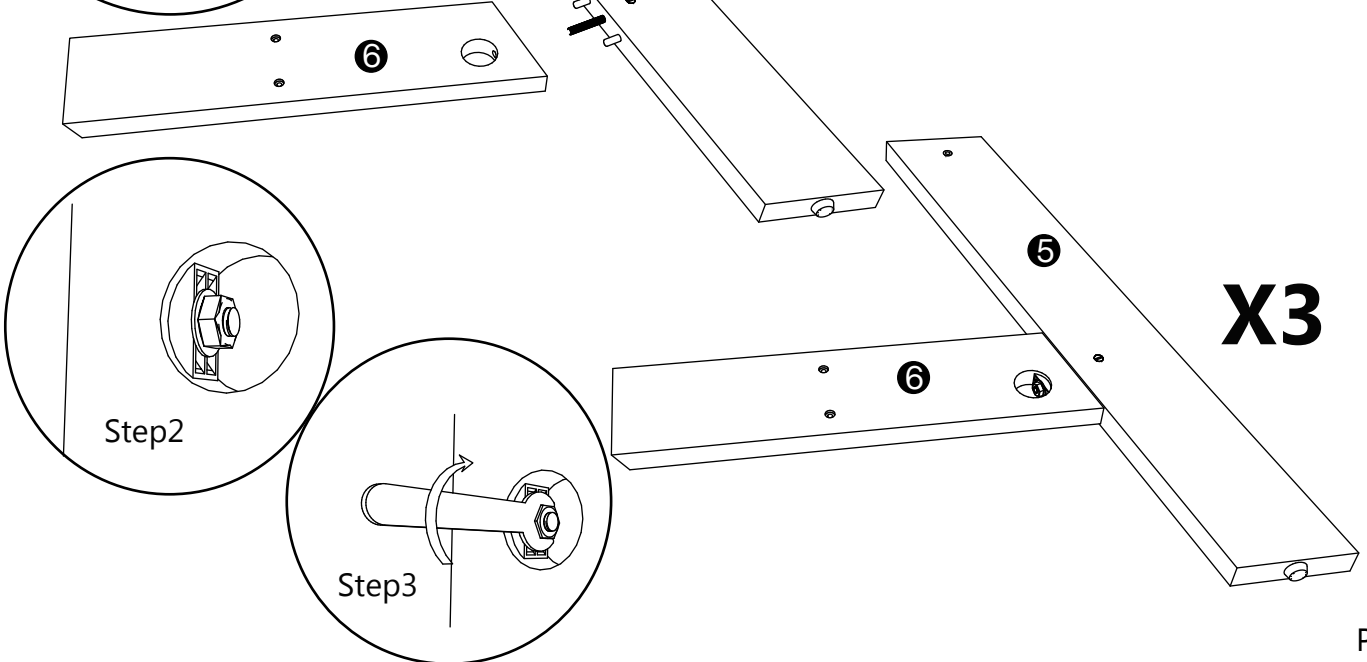

**X3**

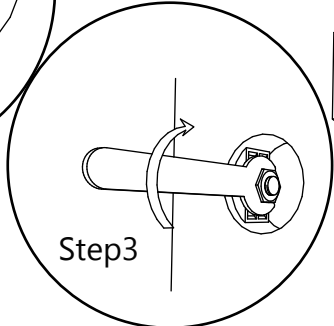
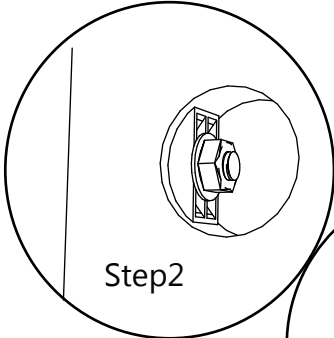

2



M6\*25



6pcs

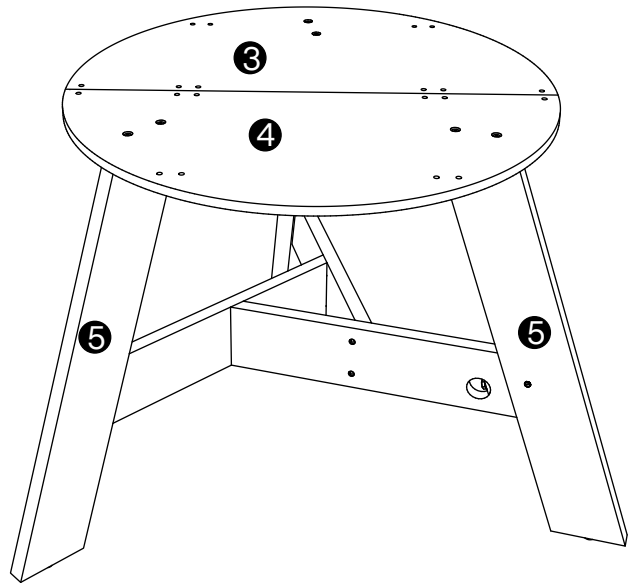
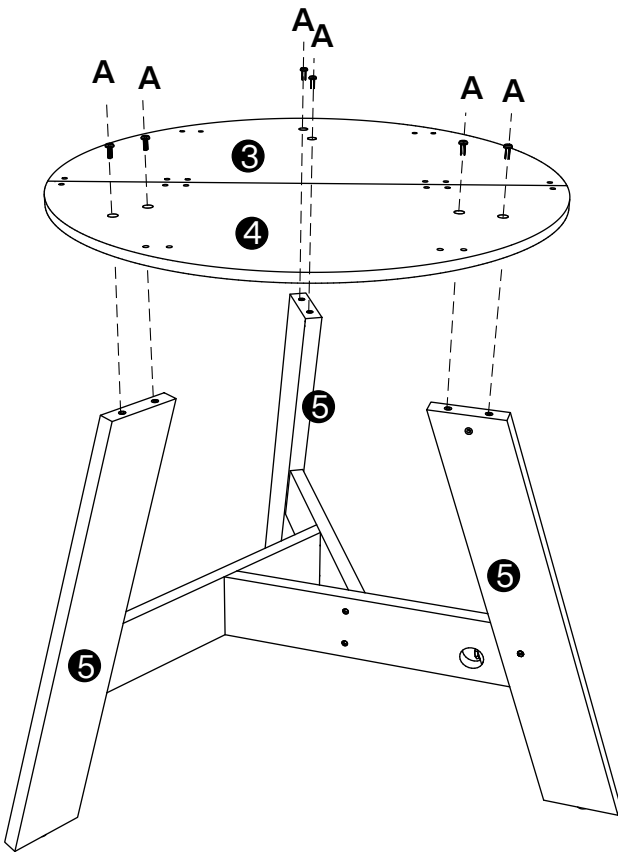

6pcs

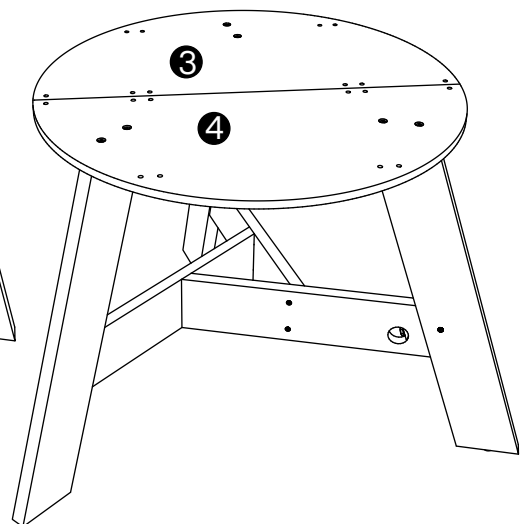
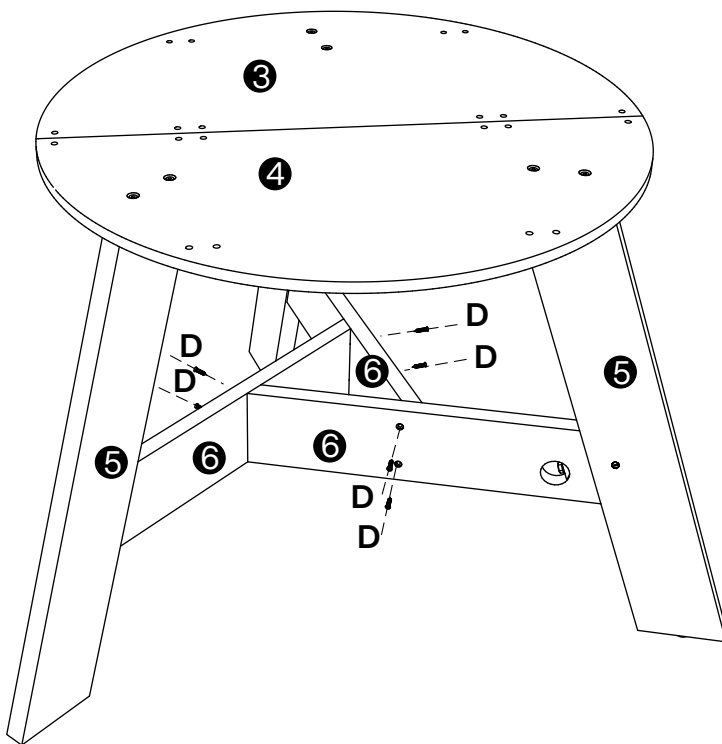



3

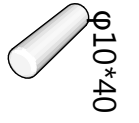

**P**

8pcs

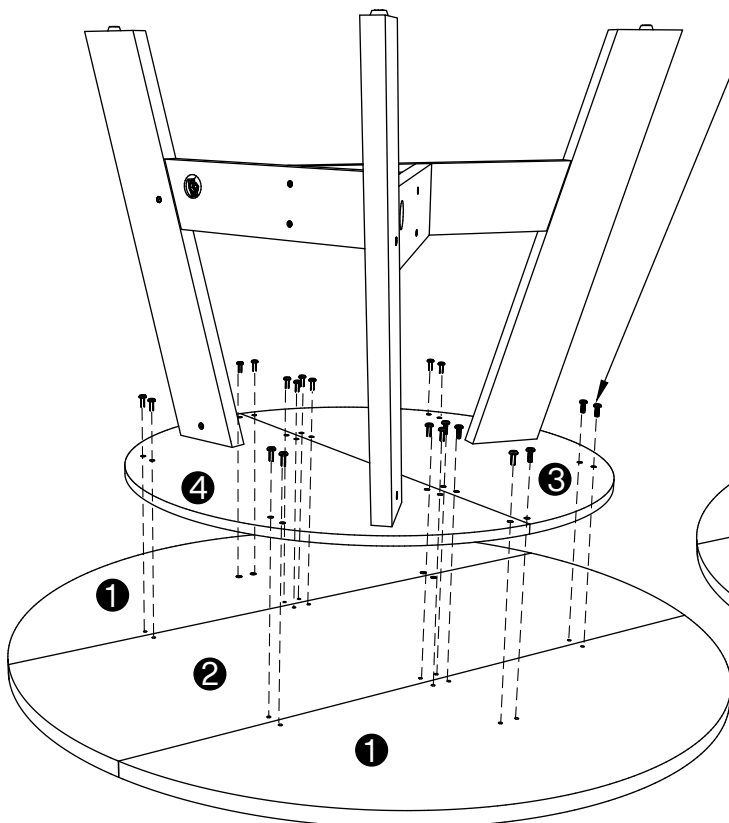
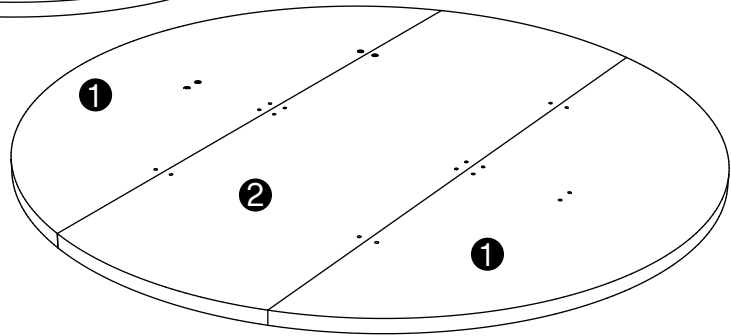
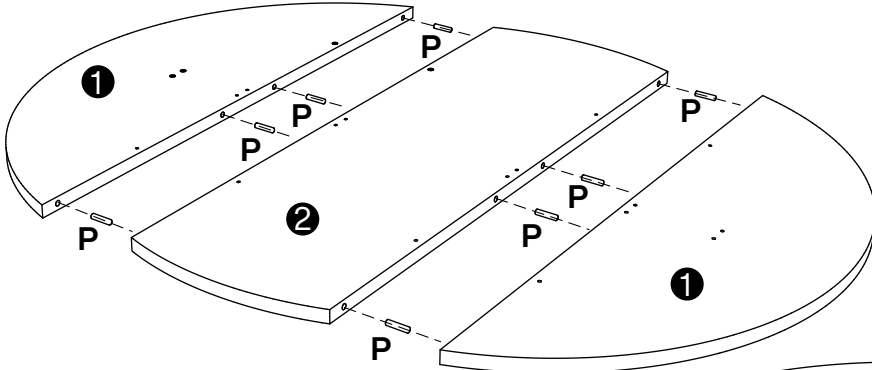

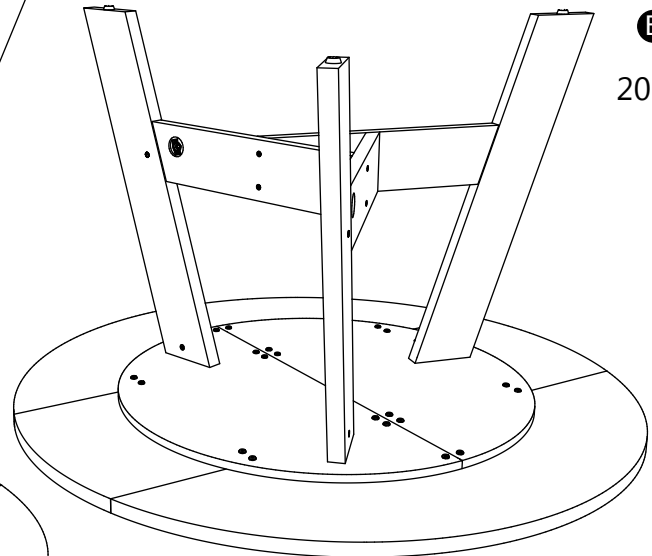

**B**

20pcs



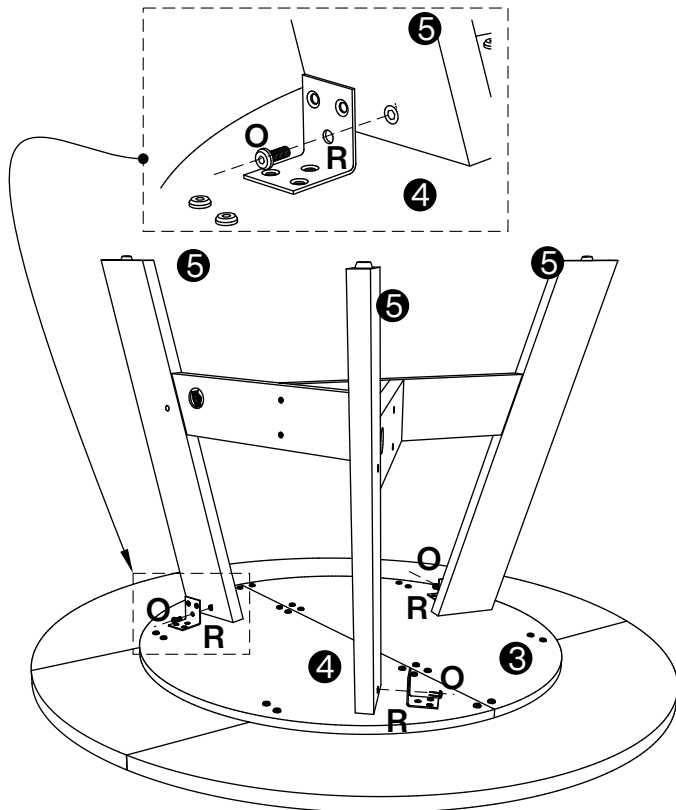

4

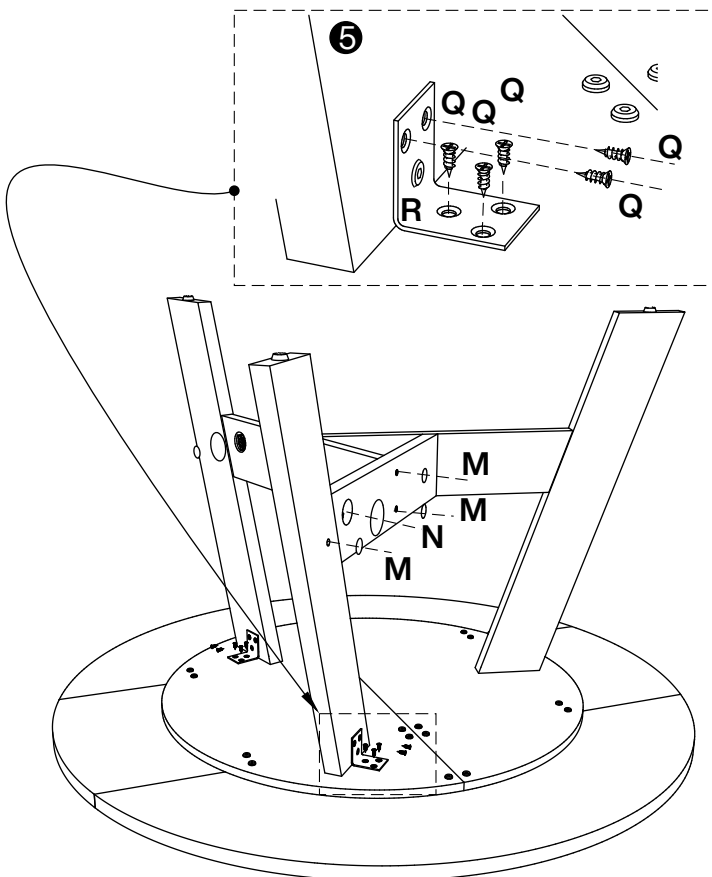
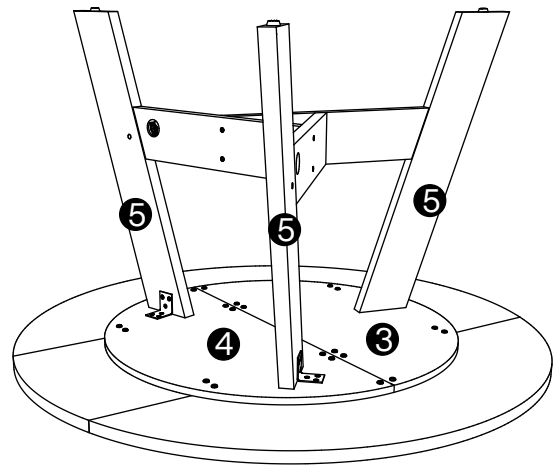

-  **R** 3pcs
-  M6\*15 **O** 3pcs

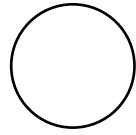

-  **M** 9pcs
-  **N** 3pcs
-  **Q** 15pcs

There are no holes predrilled.  
Please screw the sliders directly.

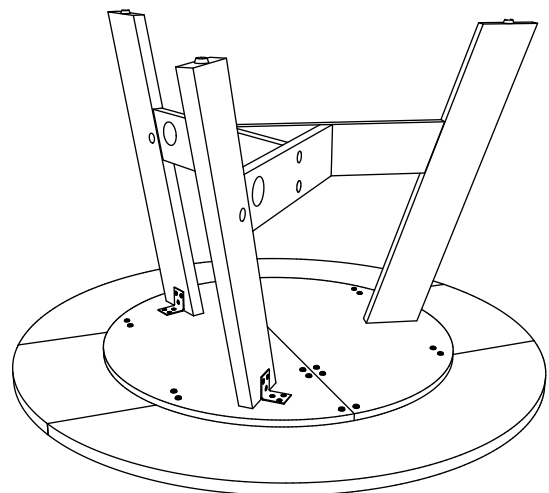

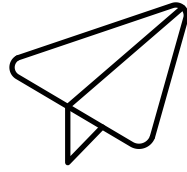

# No heartburn, when we handle the return

---

## Our way



support@tribesigns.com



Replacement/Refund



You

## Their way



Re-package item



Schedule pick-up



Track package



Replacement



You

Contact our customer service team



support@tribesigns.com  
www.tribesigns.com



1-424-220-6888