

Tribesigns

LITTLE TREE

Assembly Instructions

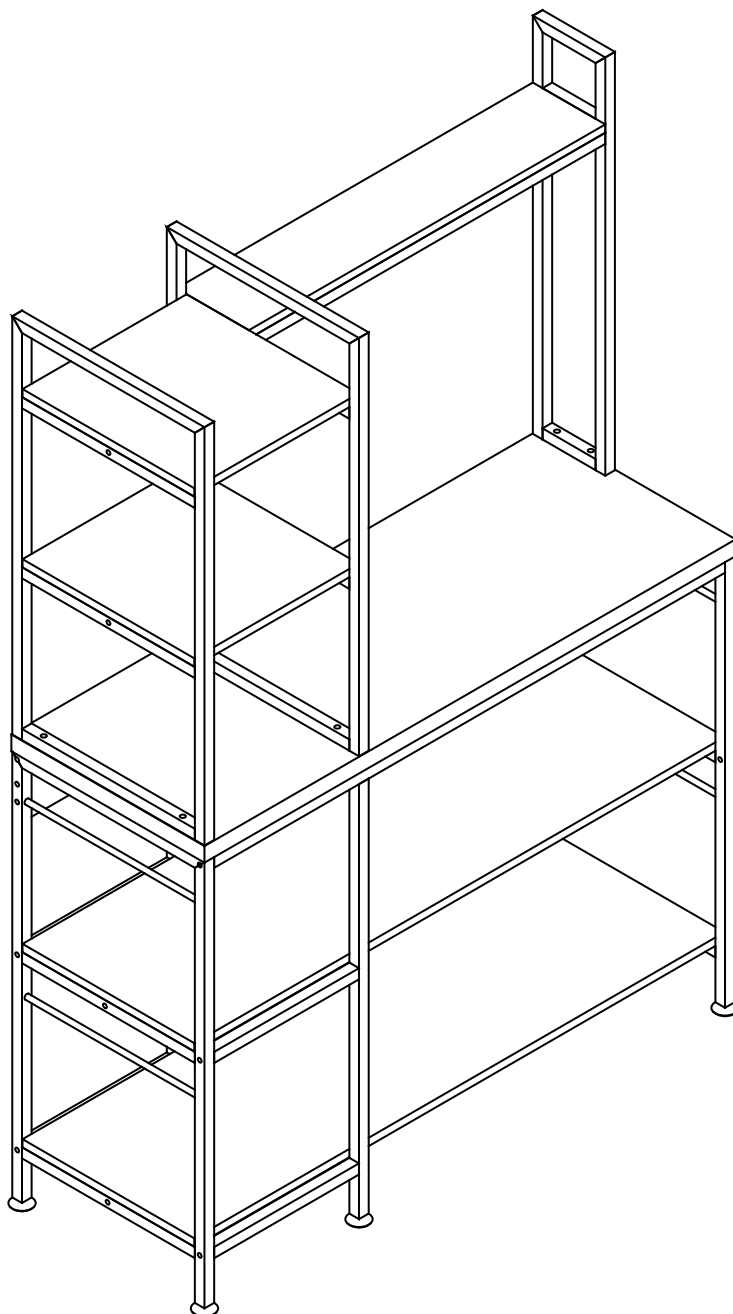

Model No. HQ0016/HQ0023/U0160

Kitchen shelf

Call us!

We're here to help!

If you have any issues with this product, please contact our customer service team **before returning** it.



We want you to be completely satisfied with your purchase! If anything is missing, damaged, incorrect, or not what you expected, don't worry. Please keep the outer packaging and take photos of both the packaging and products, and then reach out to us at **support@tribesigns.com** or call us at **1-424-220-6888**. We'll take care of everything and send you a free replacement, so you can enjoy your purchase as soon as possible without any hassle.

Assembly Instructions:

1. Carefully read these instructions and keep them for future reference.
2. Refer to the parts list for guidance and ensure that you have all the pieces before starting the assembly process, if anything is missing, damaged, incorrect, contact us **FIRSTLY BEFORE** assembling.
3. When assembling, place all parts on a soft, clean, and flat surface, such as a carpet, to prevent any scratches.
4. To avoid misalignment of the holes, Please don't full tighten the screws until you ensure all parts in place.

Follow Tribesign:



Facebook



Twitter



Pinterest



YouTube



Instagram

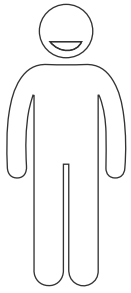

X2

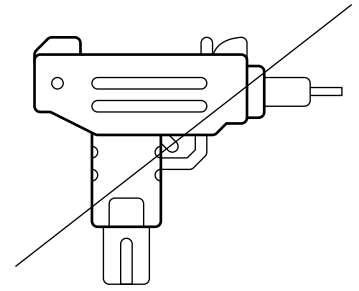
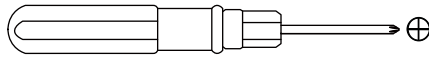

When using the electric screwdriver ,
Reduce the power and torque to avoid damaging the furniture

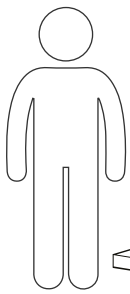

?

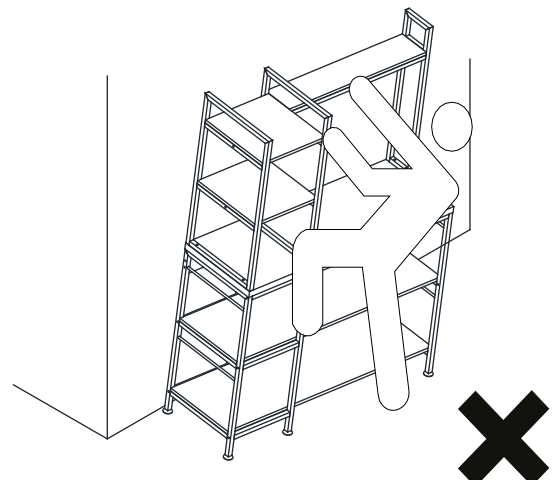
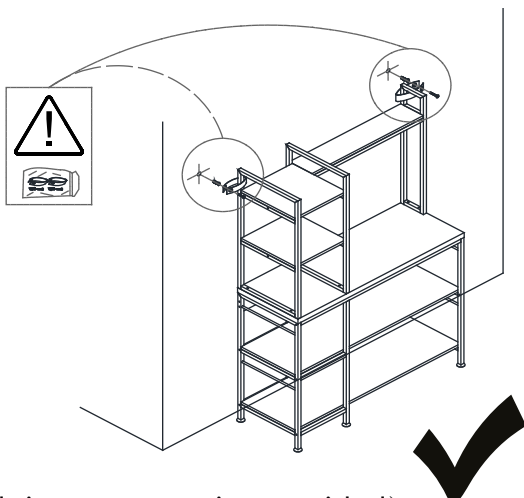
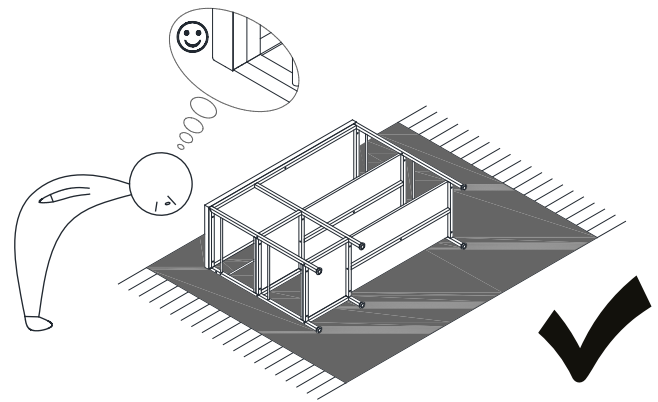
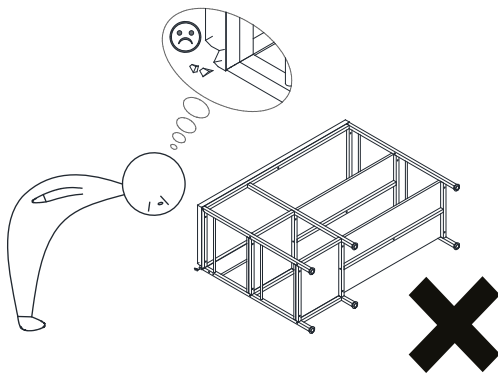
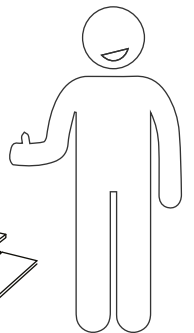
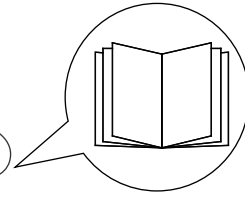
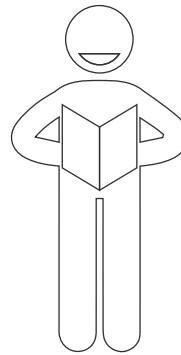
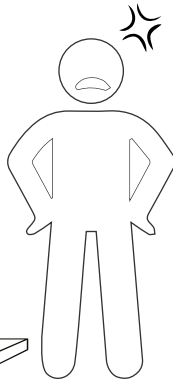

(Install tip-over restraint provided)

Use of tip-over restraints may only reduce but not eliminate,
the risk of tip-over.

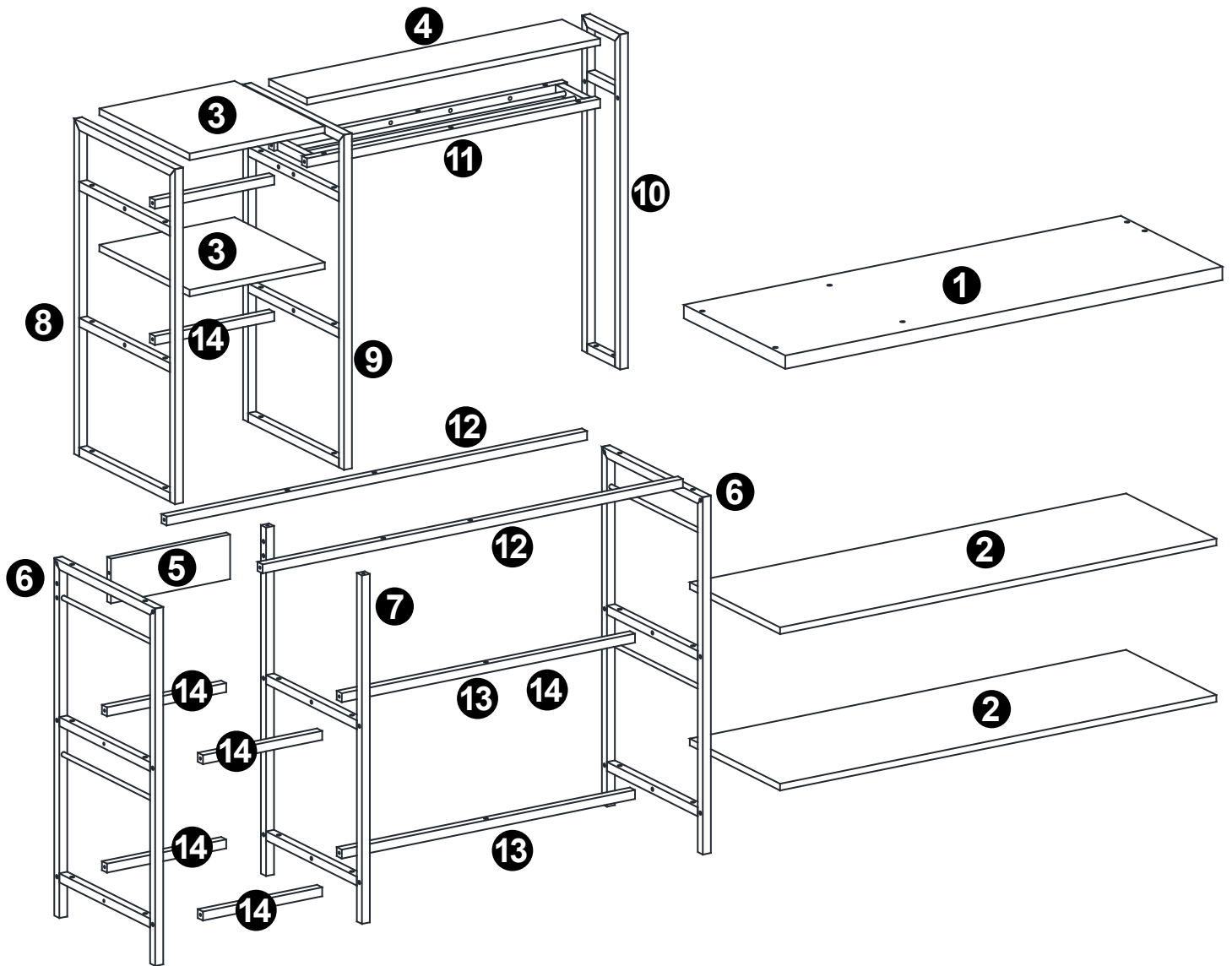

⚠ Caution

Make sure all parts are included. Most board parts are labeled or stamped on the raw edge. Contact us for free replacement if having damaged or missing parts.

Parts & Hardware List

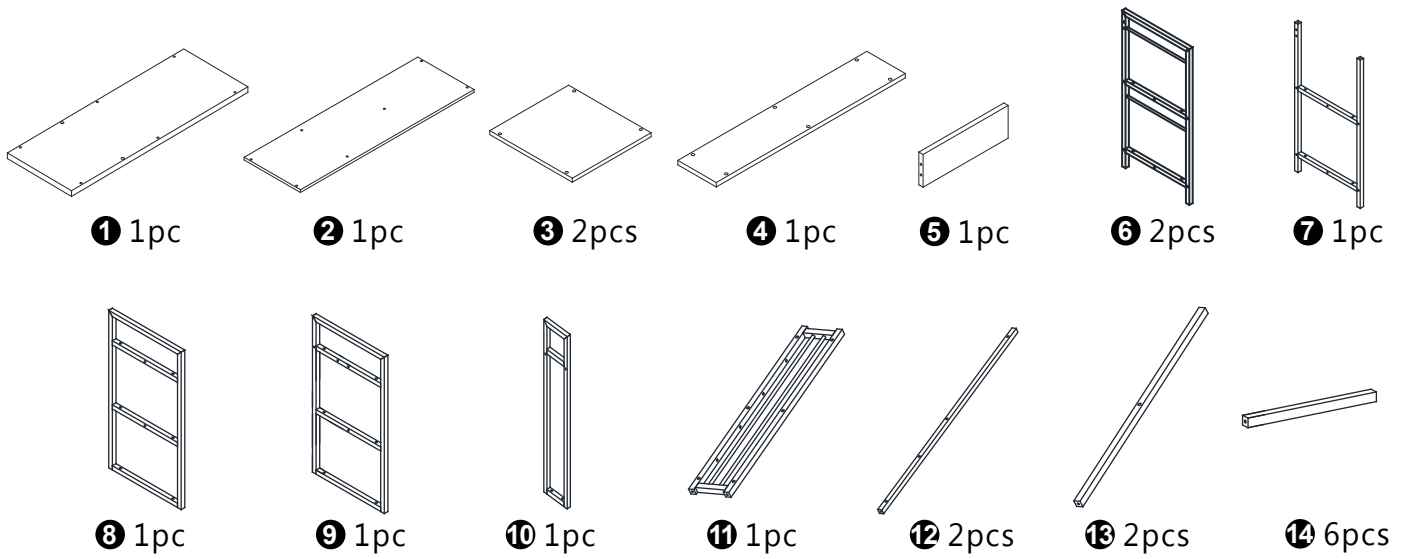

Hardware List

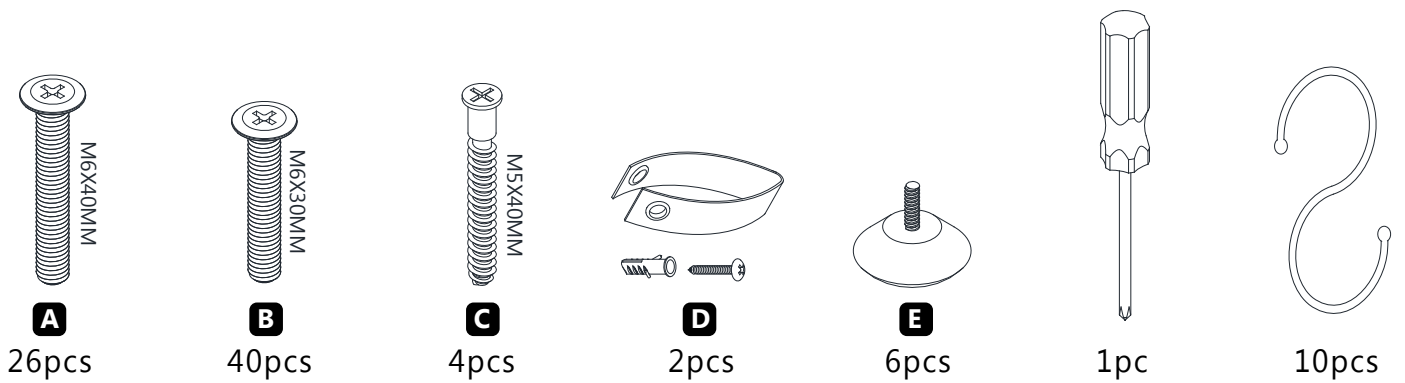

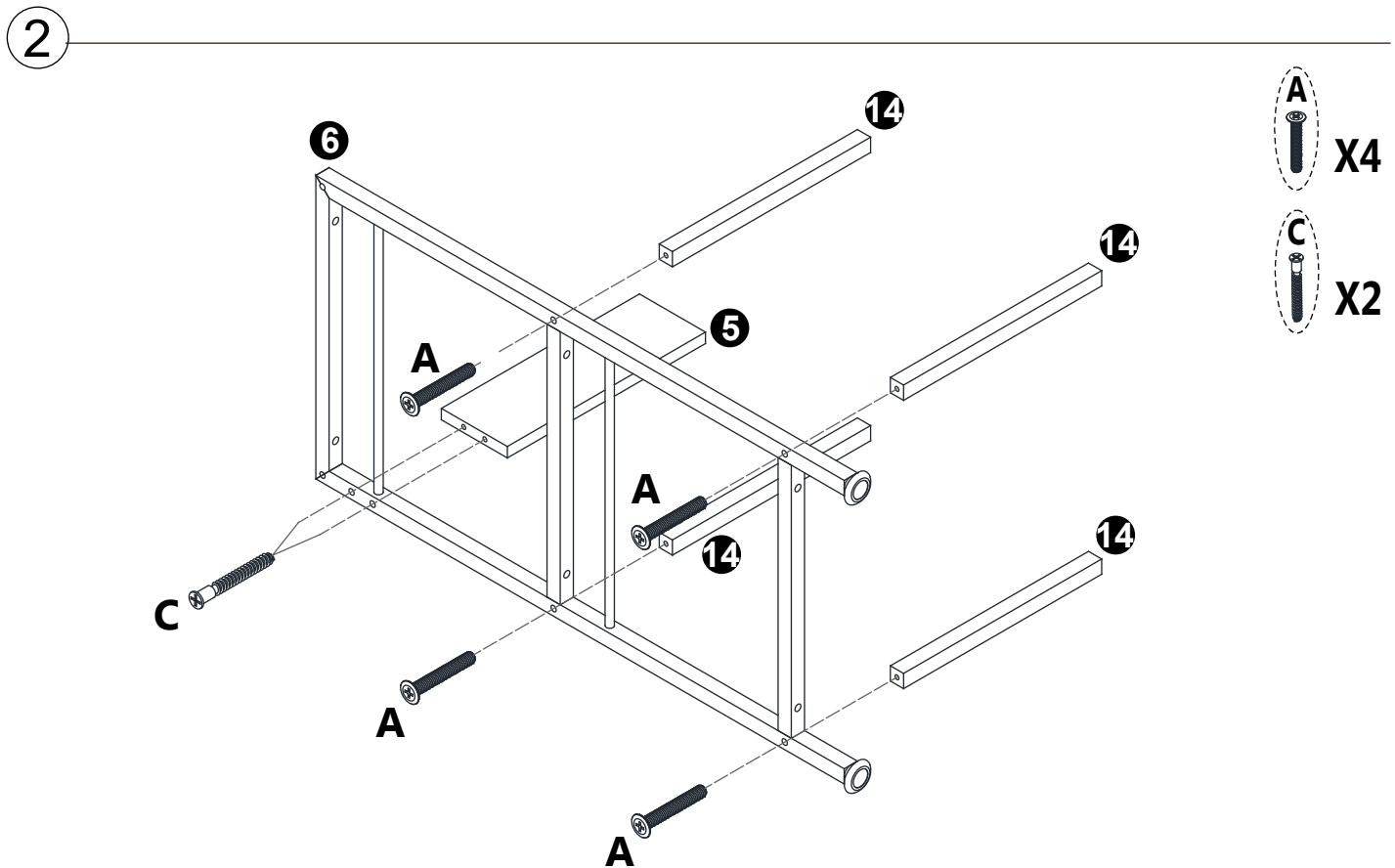
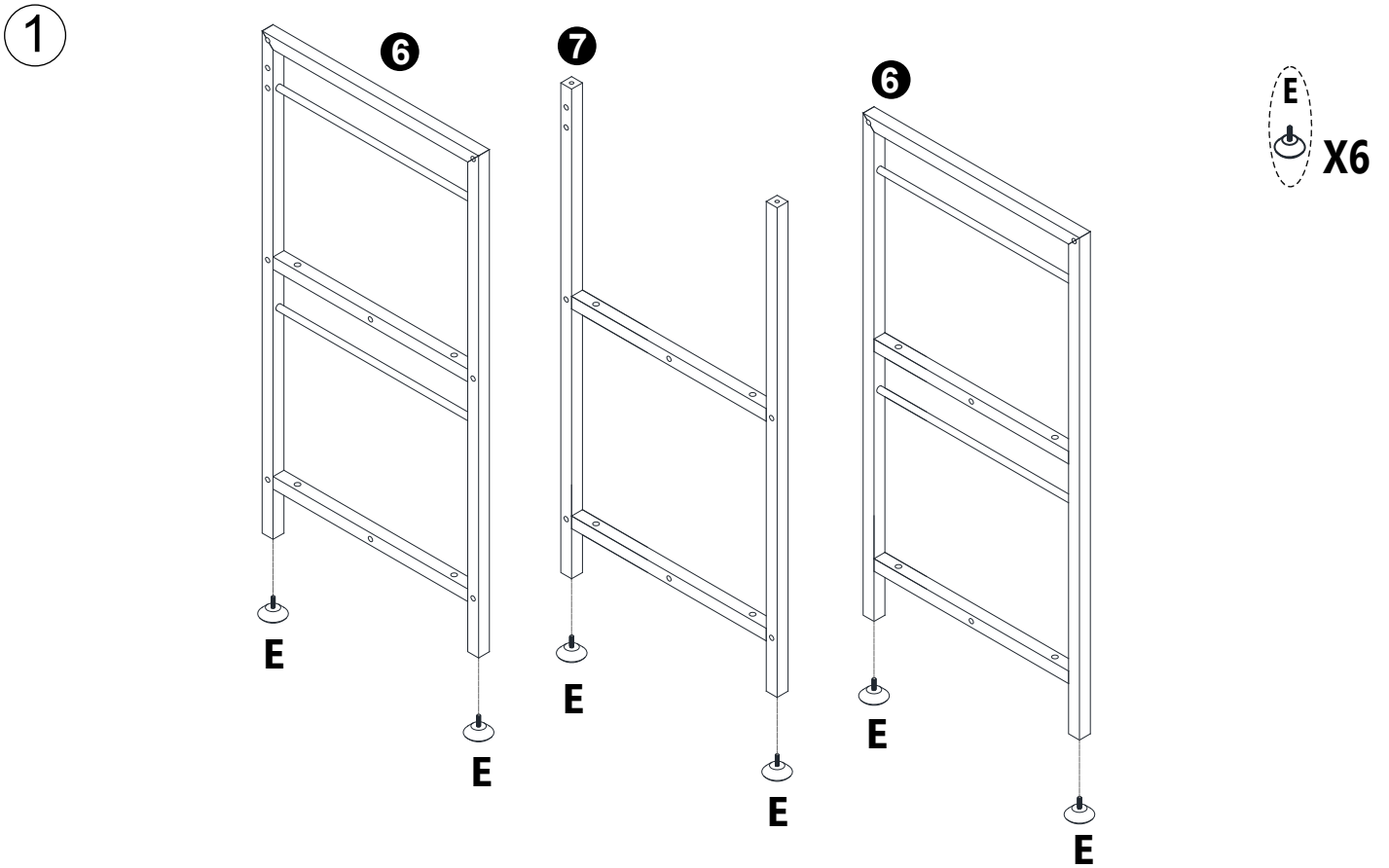

3

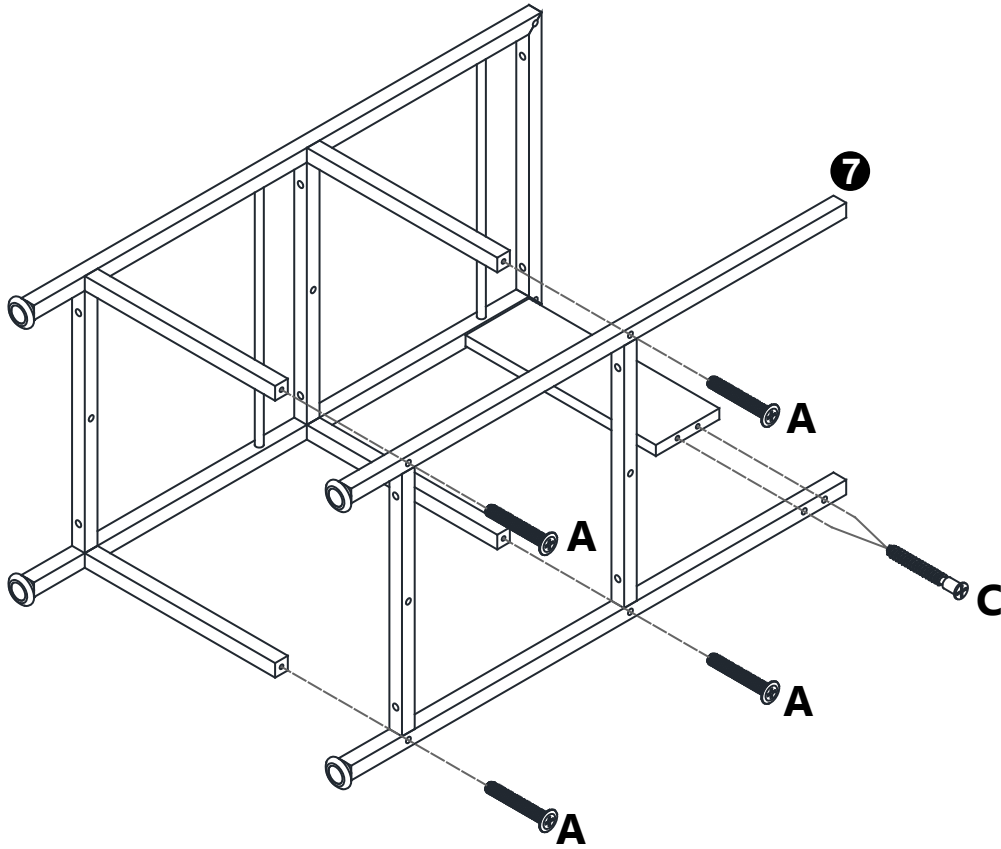

- A X4
- C X2

4

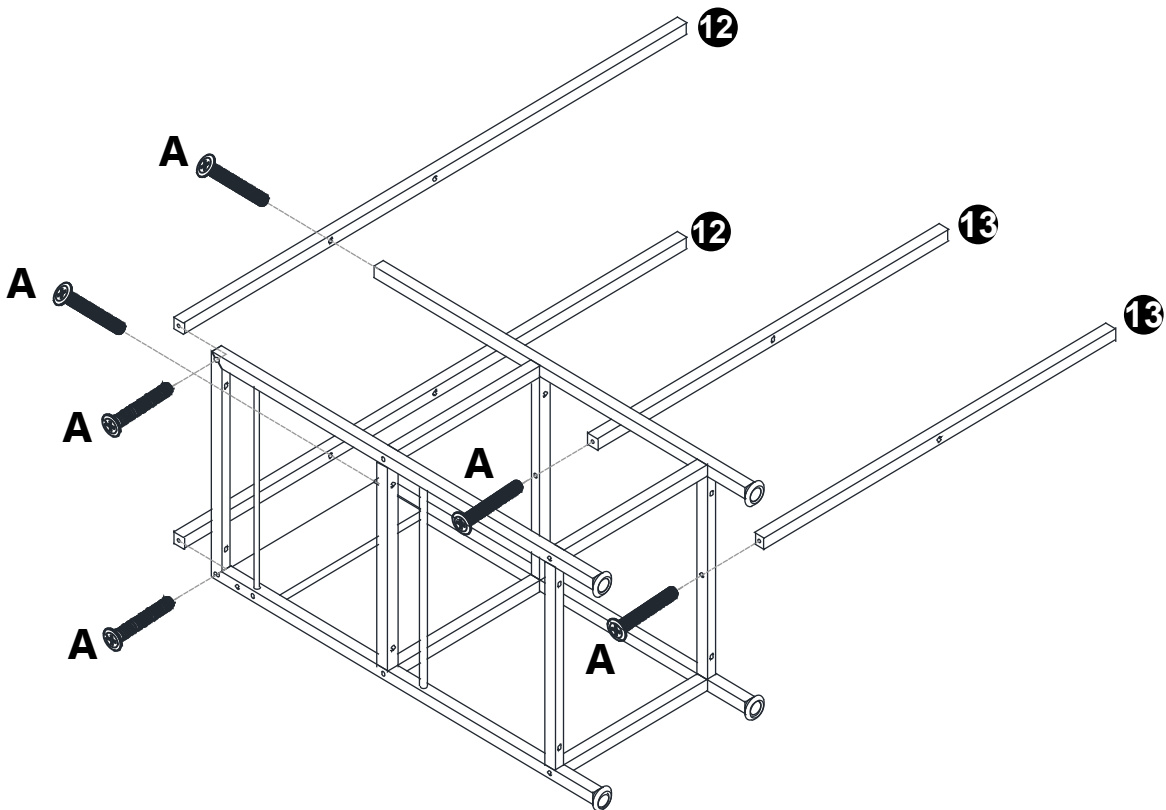

- A X6

5

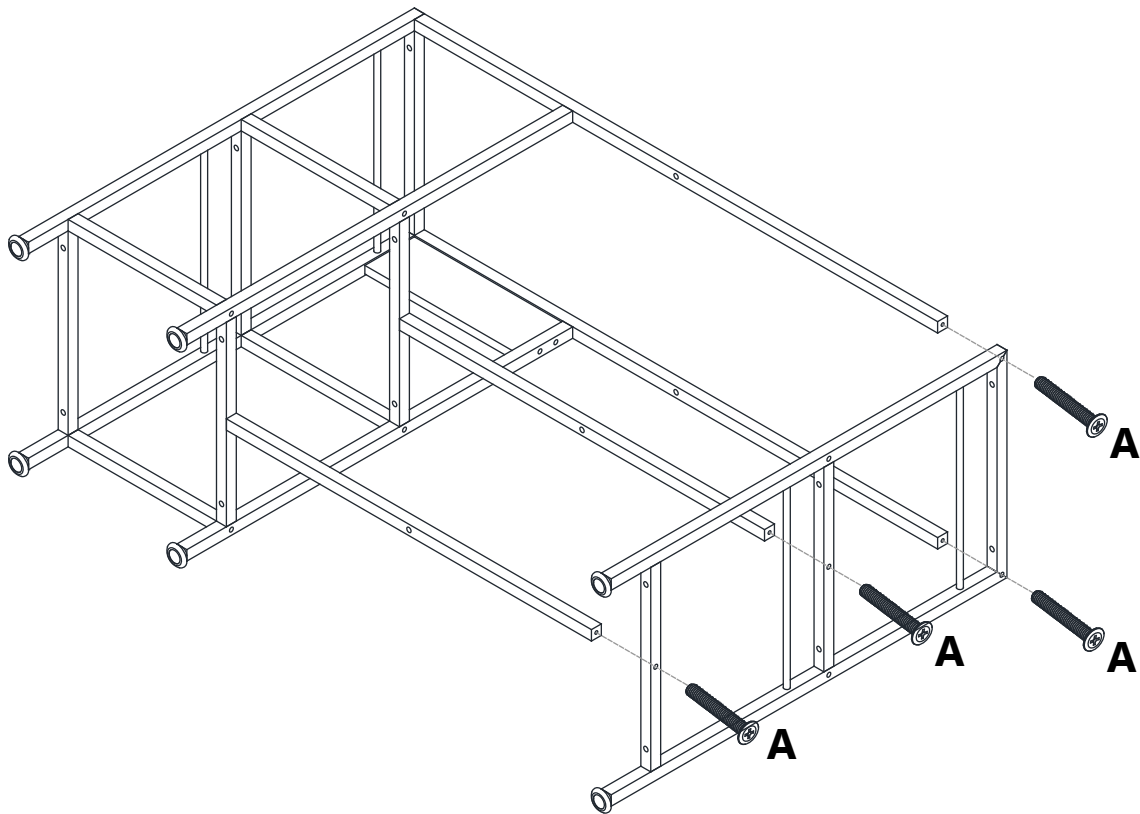

6

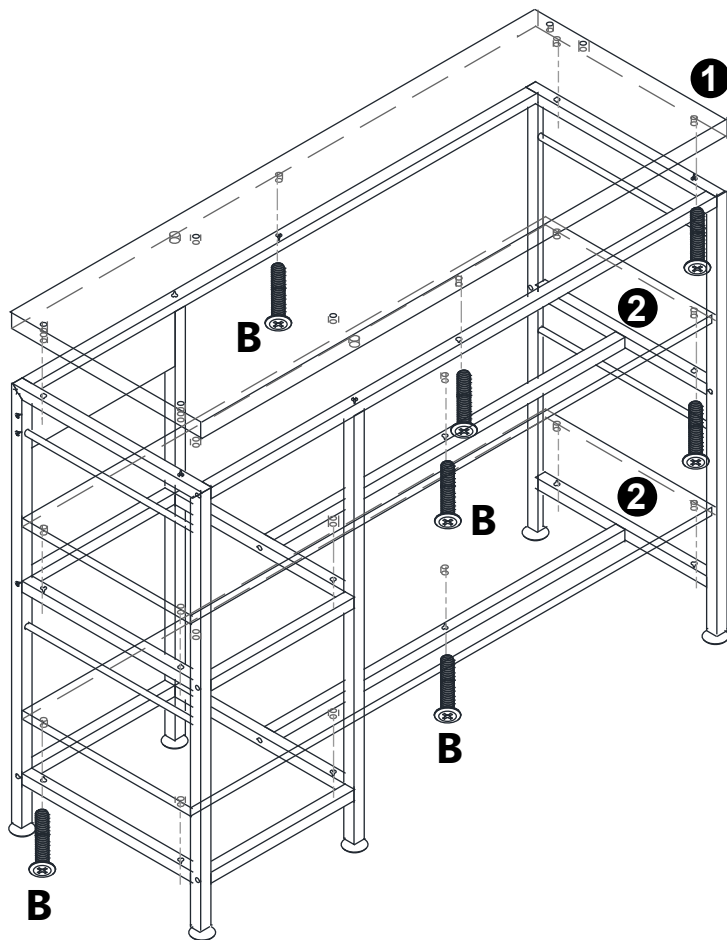

7

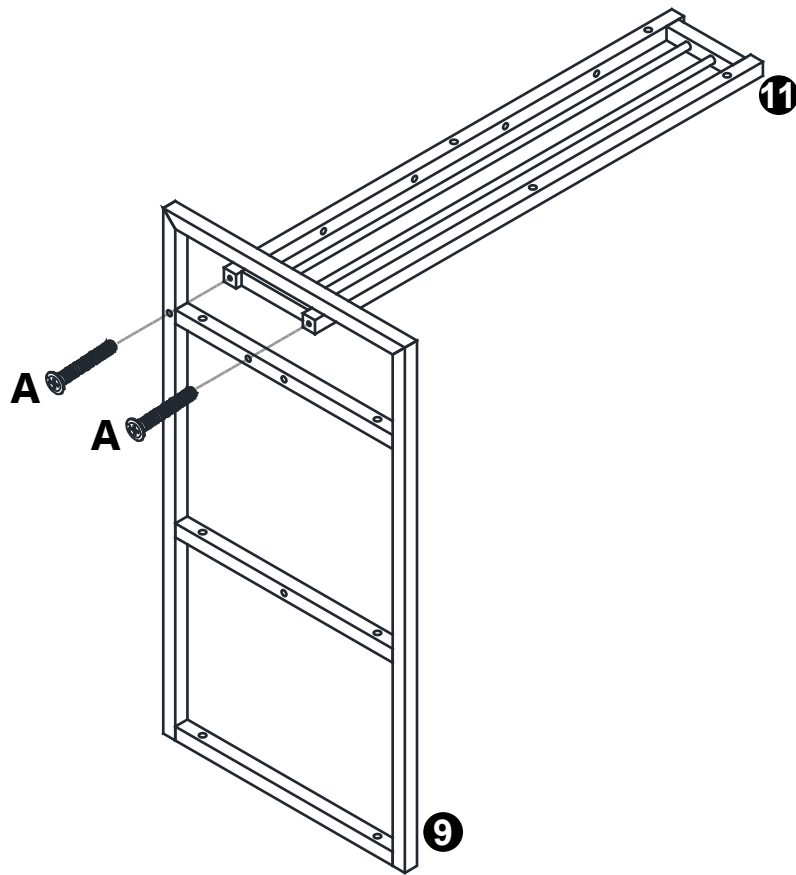

8

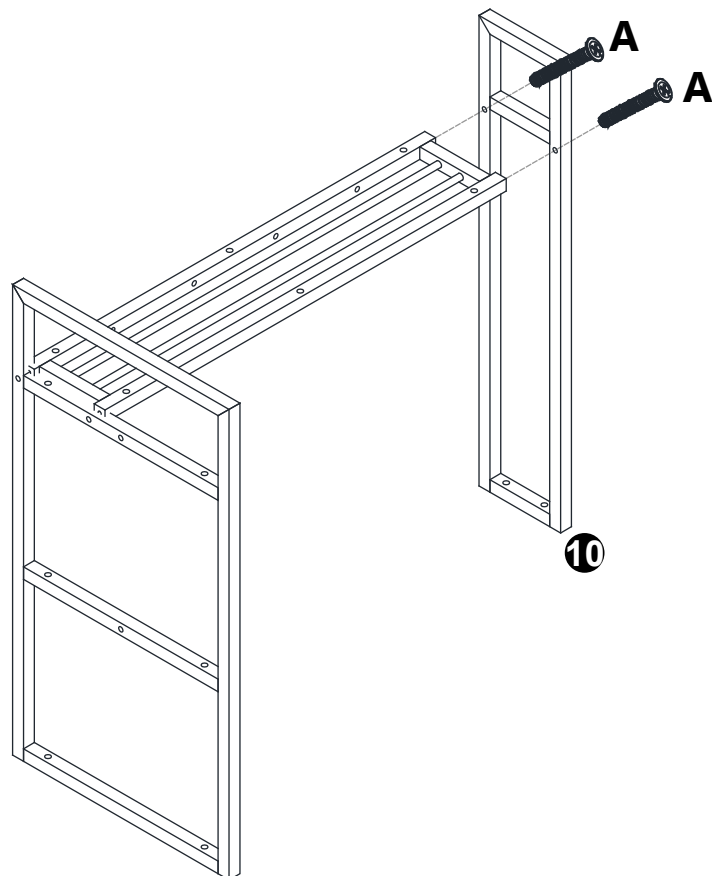

9

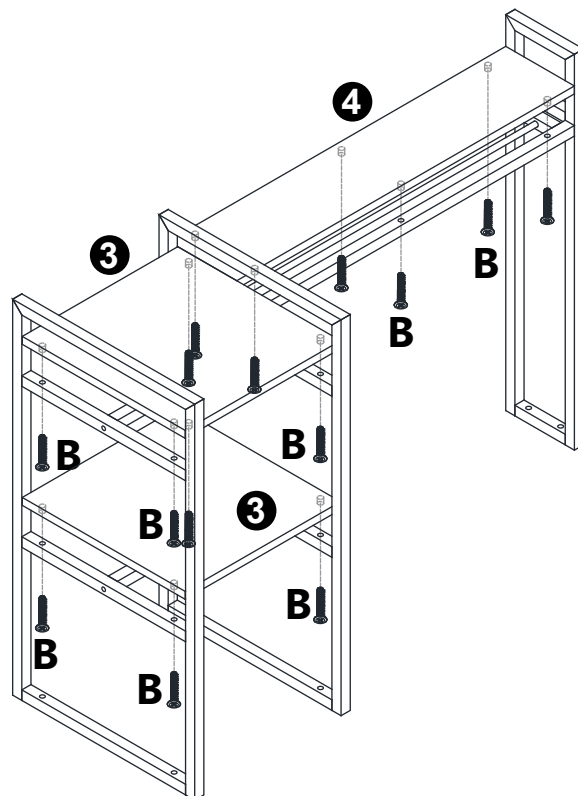

B
X14

10

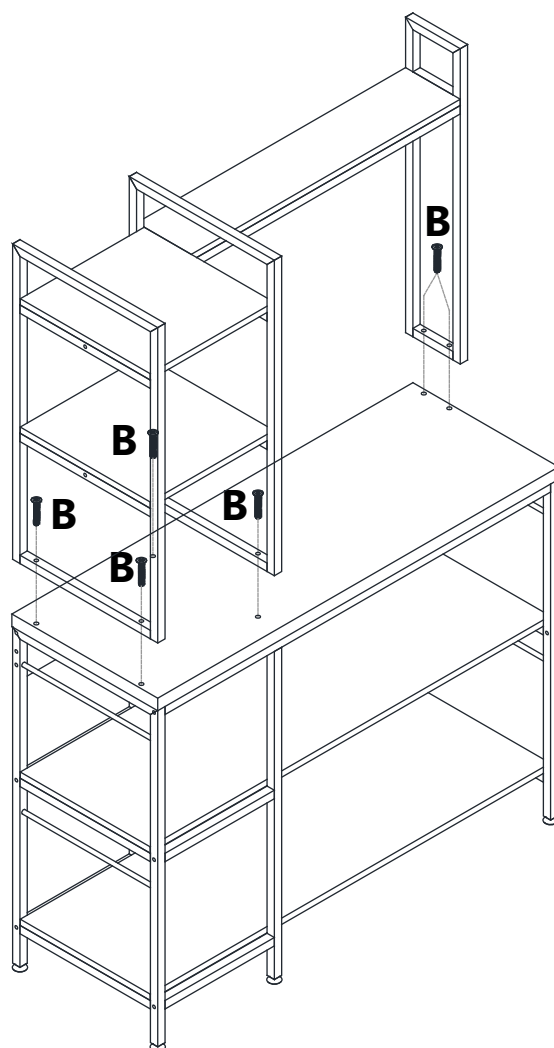

B
X6

11

D
X2

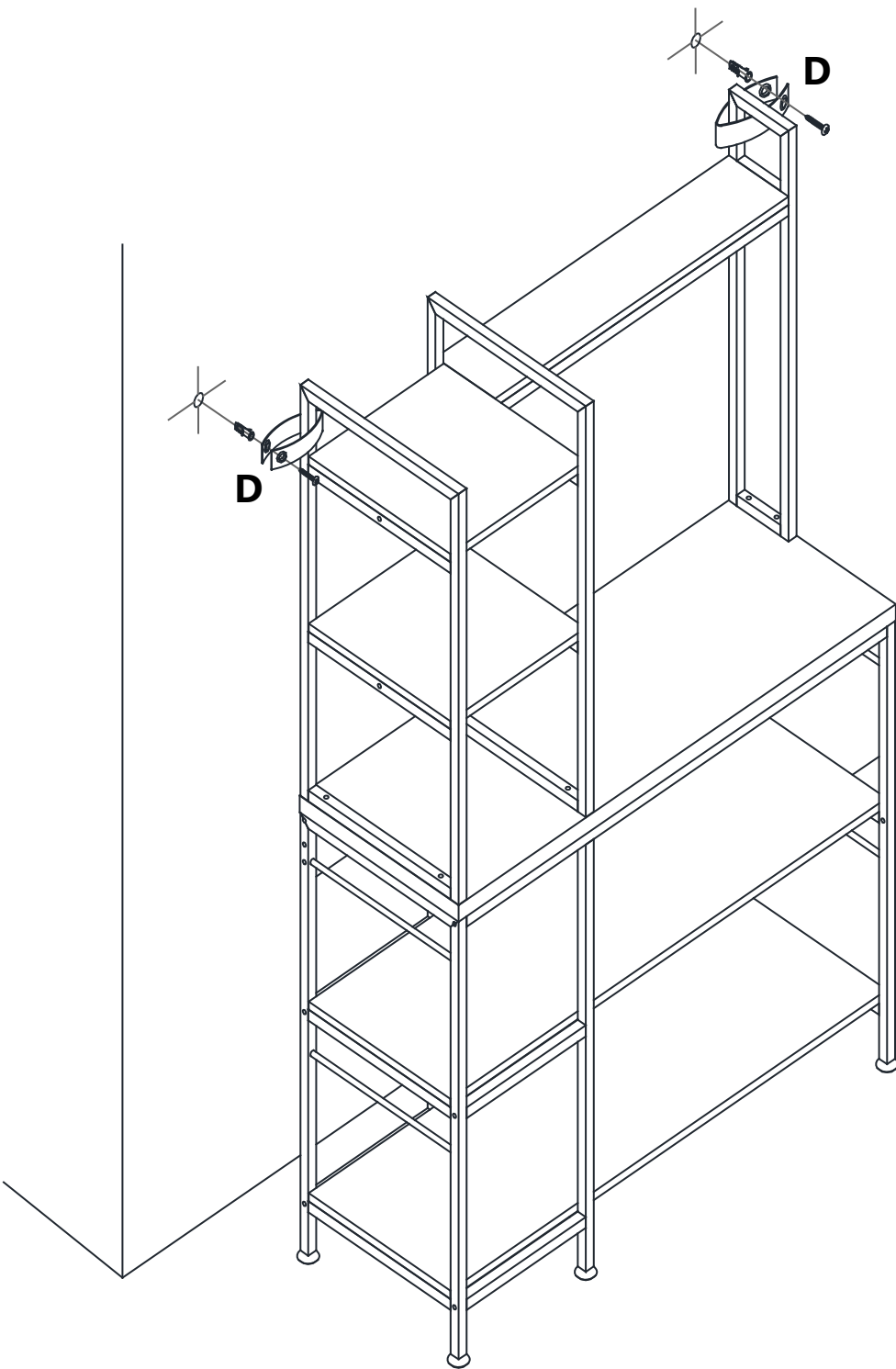

Attention: For safety and stability, we suggest you have to secure the anti-tip accessories to the wall to prevent tipping, injury, and property damage.

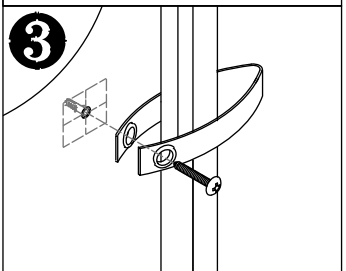
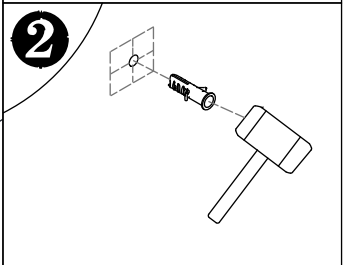
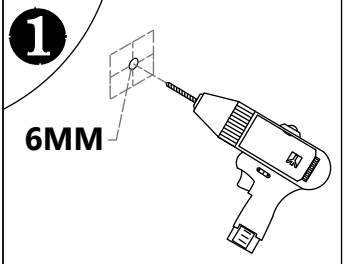

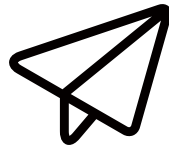

No heartburn, when we handle the return

Our way

 support@tribesigns.com

 Replacement/Refund

 You

Their way

 Re-package item

 Schedule pick-up

 Track package

 Replacement

 You

Contact our customer service team



support@tribesigns.com
www.tribesigns.com



1-424-220-6888