

**Stream**<sup>®</sup>  
*Sign of Quality*

# HYDROBOX 900

## AIO Water Pressure System

HYDROBOX 900 is a fully integrated, self-priming, compact all-in-one water pump for pressure boosting in domestic applications.



### Perfect Water Pressure

*Integrated Inverter Control System*  
Constant Pressure at any time



### Breakthrough of Pump Energy-saving

*Variable-frequency permanent magnet motor*  
Low consumption and compact structure



### Knockout among Pump World

*Compact and fashion design*



### Reliability with Multi-protections



Overheat Protection



Overload Protection



Low-Water Protection



Low-voltage Protection



Crash Protection



Failure Alarm



[www.streampumps.com](http://www.streampumps.com)





## Interactive Interface

Auto and manual mode to adjust pressure independently

## Performance

Hydrobox 900 is equipped with inverter technology to maintain constant pressure and save energy at the largest degree.

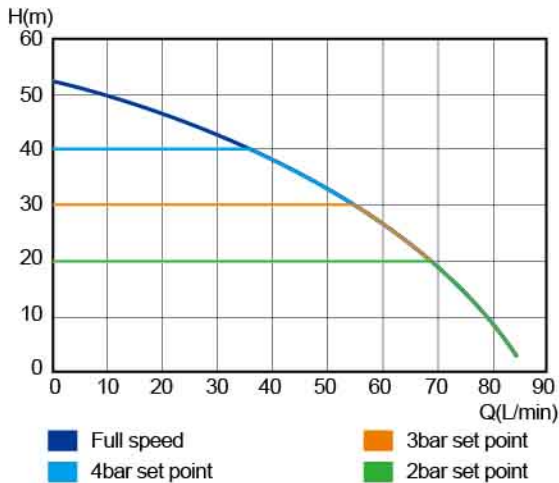

## Applications

It is designed to handle the pressure boosting in residential buildings and villas.

- Pressure boosting of city mains water
- Pressure boosting of roof tank, break tank and ground tank
- Water supply from shallow wells

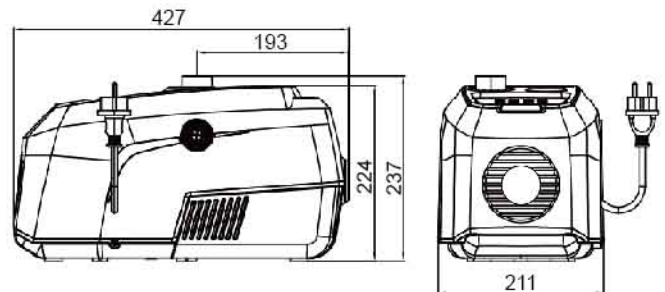

## Technical Data

Model	Voltage	Input Power	Max. Head	Max. Flow	Inlet & Outlet	Liquid Temp.	Max. Pressure	IP and IC
Hydrobox 900	160-250V 50Hz-60Hz	900W	50m	80L/min	1" G	0-55°C	6bar	IP54, F

## Exploded View

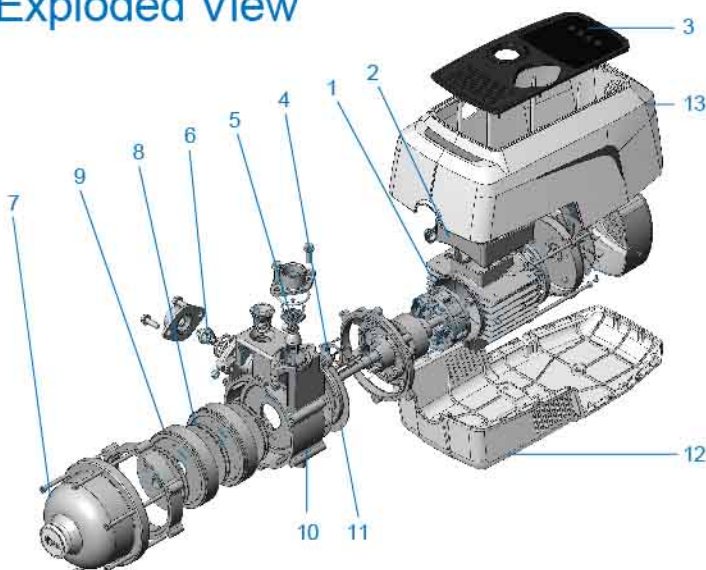

NO.	DESCRIPTION	Material
1	Permanent Magnet Motor	
2	Control Drive	
3	Control Panel	PC+ABS
4	Pressure Sensor	
5	Outlet Check-valve	POM
6	Inlet Check-valve	POM
7	Pressure Tank	S.S304
8	Impeller	S.S304
9	Diffuser	PPO+GF30
10	Pump Head	PPO+GF30
11	Pump Cover	S.S304
12	Pump Base	PC+ABS
13	Shield Cover	PC+ABS