



LA SAL

I N S T A L L I N S T R U C T I O N S

HARDWARE CHECKLIST

Exact hardware counts may vary based on the options selected at checkout.

24

Carriage Bolt
(1/4"-20 x 1")



40

Socket button
(1/4"-20 x 1")



16

Hex bolt
(1/4"-20 x 9/16")



6

Socket Button
(1/4"-20 x 1/2")



8

Hex bolt
(M5 x 16mm)



22

1/4"-20"
T-nut



8

M5 Bonded
washer



86

1/4" Flat
washer



16

1/4" Split
washer



8

Mounting
Bracket
Assemblies

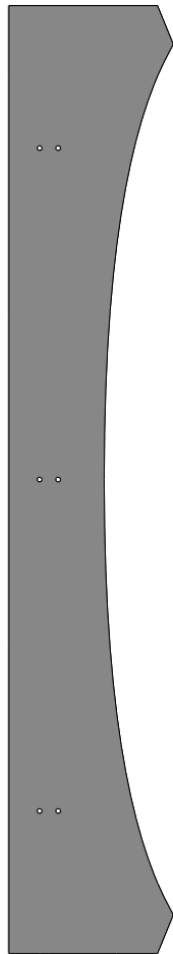
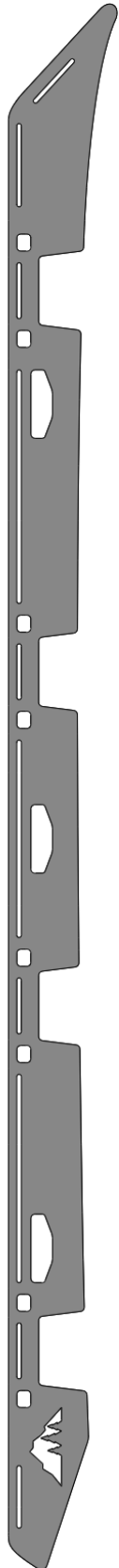
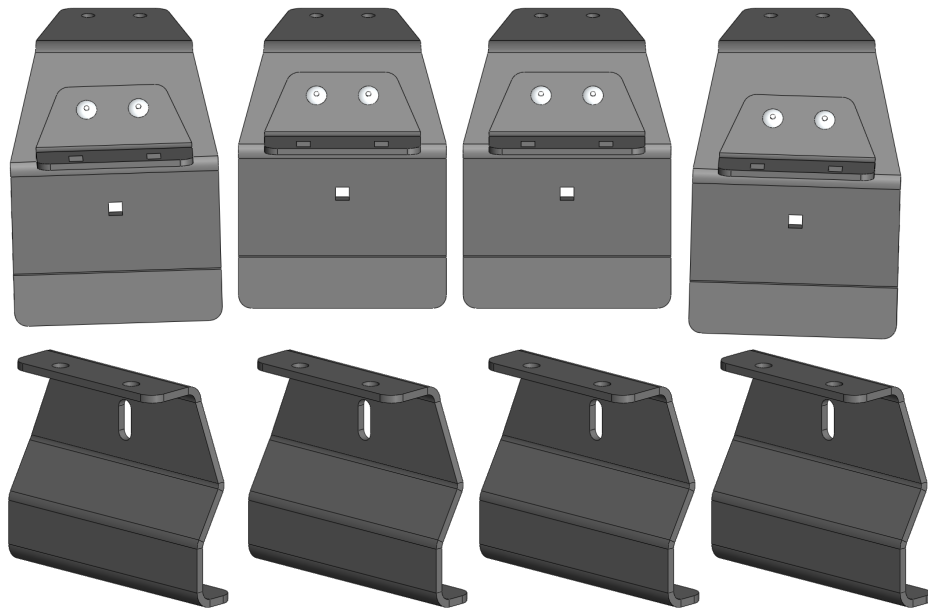

USING TNUTS

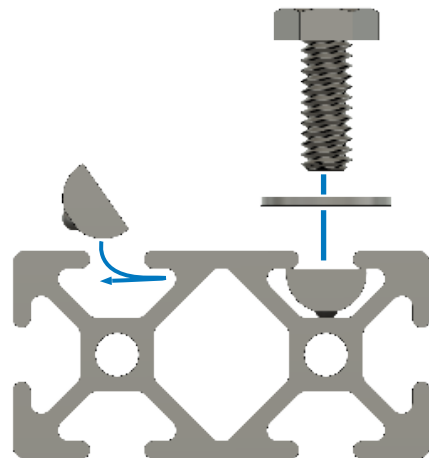

Sideplates

Extrusion
Crossbars

Wind Fairing
w/ Edge Trim



BEFORE YOU BEGIN

Want a step-by-step walkthrough? Want to hear the sweet sound of Chase's voice? There is a comprehensive installation instruction video available for this roof rack.

Sherpa Equipment website:

<https://sherpaequipmentco.com/instructions>

Youtube:

<https://www.youtube.com/@sherpaec>

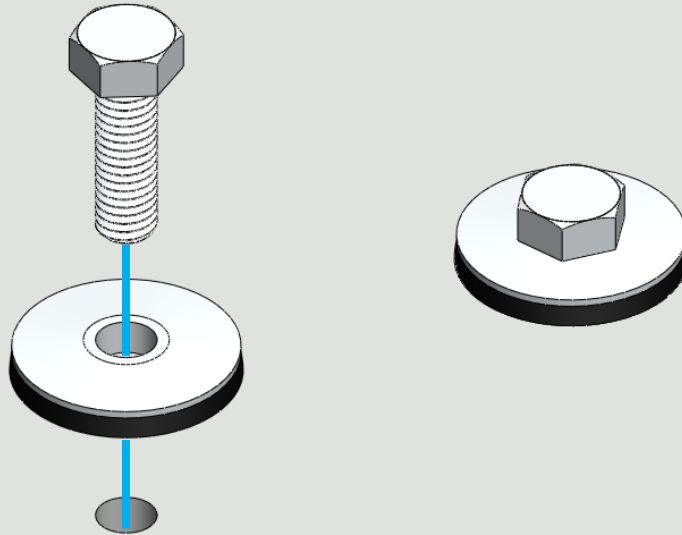

SETUP

Required Components:

8x M5 x 16mm Hex Bolt

8x M5 Bonded Washer

Remove the factory roof rails from the vehicle, held in by Phillips head bolts through each of the four contact points to the roof.

Seal the bolt holes using the supplied M5 x 16mm bolts and bonded washers. Tighten the bolts until the rubber of the washers begin to flare out.

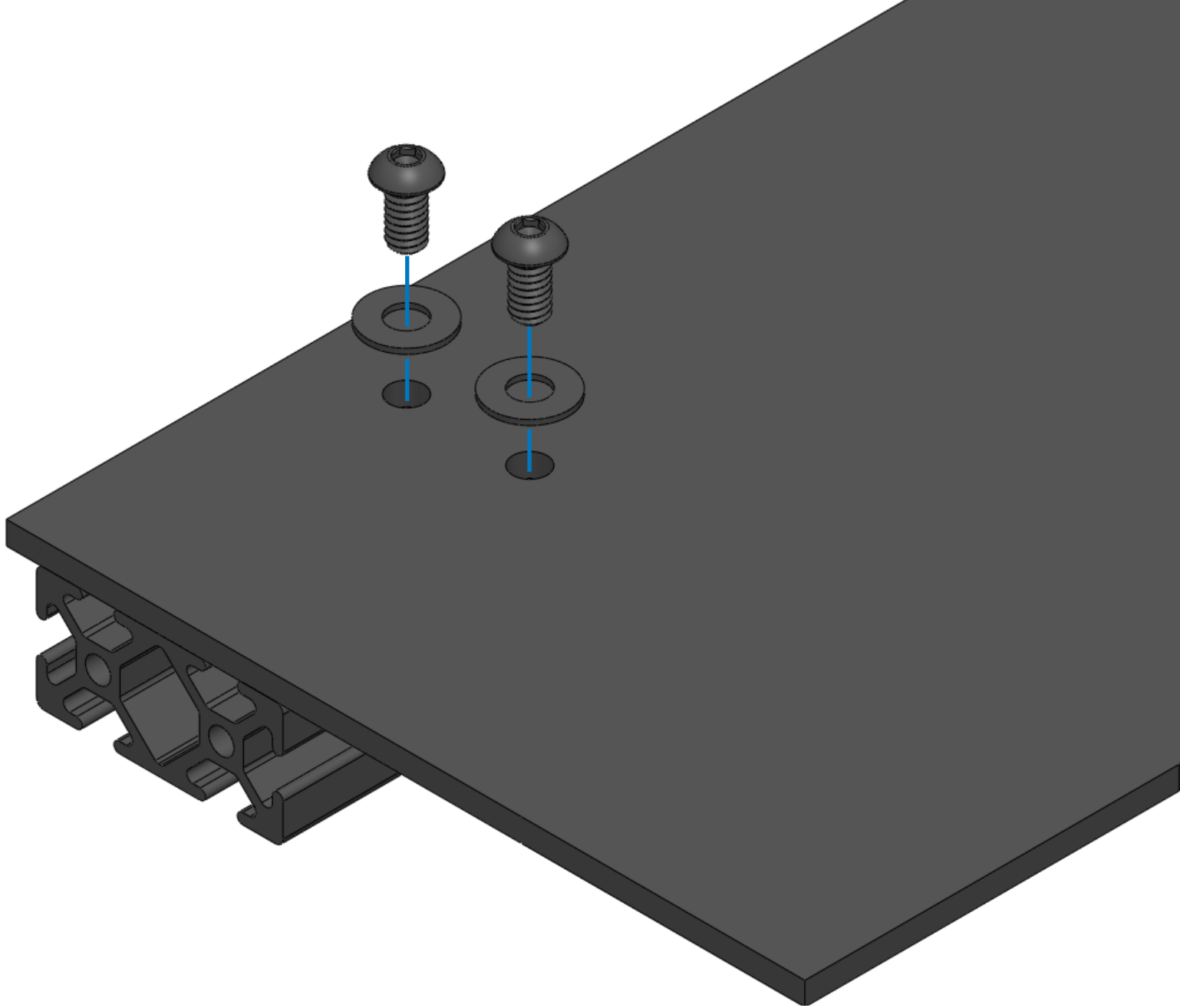

FAIRING ASSEMBLY

Required Components:

6x 1/4"-20 x 1/2"

6x 1/4" Flat Washers

6x Nuts

Drop 6 nuts into the slots on the crossbar and line them up with the holes in the fairing. Secure with six 1/4"-20 x 1/2" socket button bolts and washers.

MOUNT ASSEMBLY 01

Required Components:

24x Carriage bolt 1/4"-20 x 1"

24x Flat Washer

24x 1/4"-20 Hex Nut

16x Split Washer

The clamping mount assemblies should come preassembled in the same configuration as pictured. If any hardware has fallen off during shipping, simply reassemble according to the diagrams.

The horizontal set of hardware is the main hardware that will keep the outer clamps secured to the mounting foot assembly. Leave these loose for now.

The vertical sets of hardware act in tension as a means of keeping the roof rack on the vehicle but are **not** specifically for keeping the outer clamp attached to the mounting brackets.

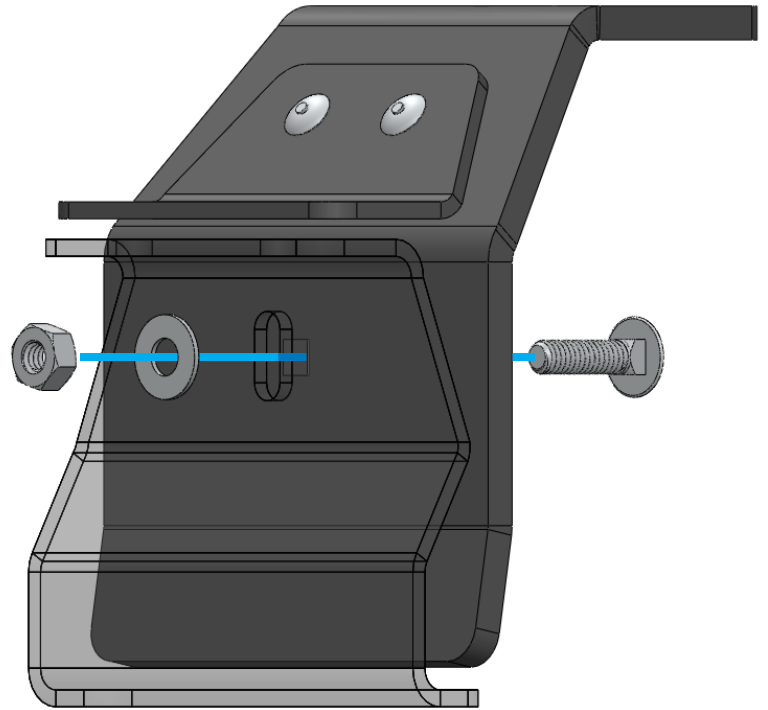

1. HORIZONTAL HARDWARE SET

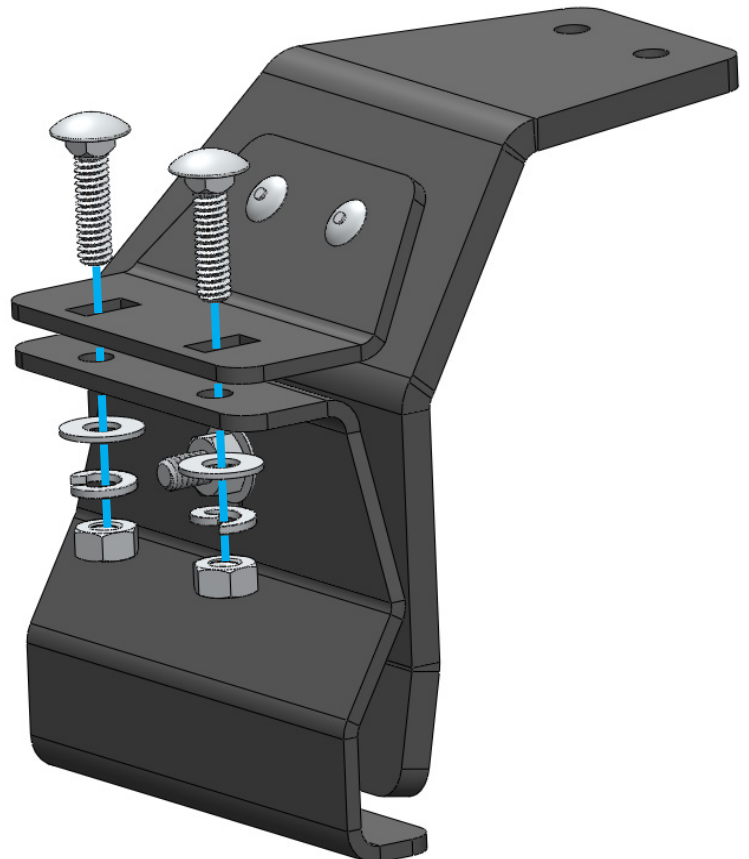

2. VERTICAL HARDWARE SETS

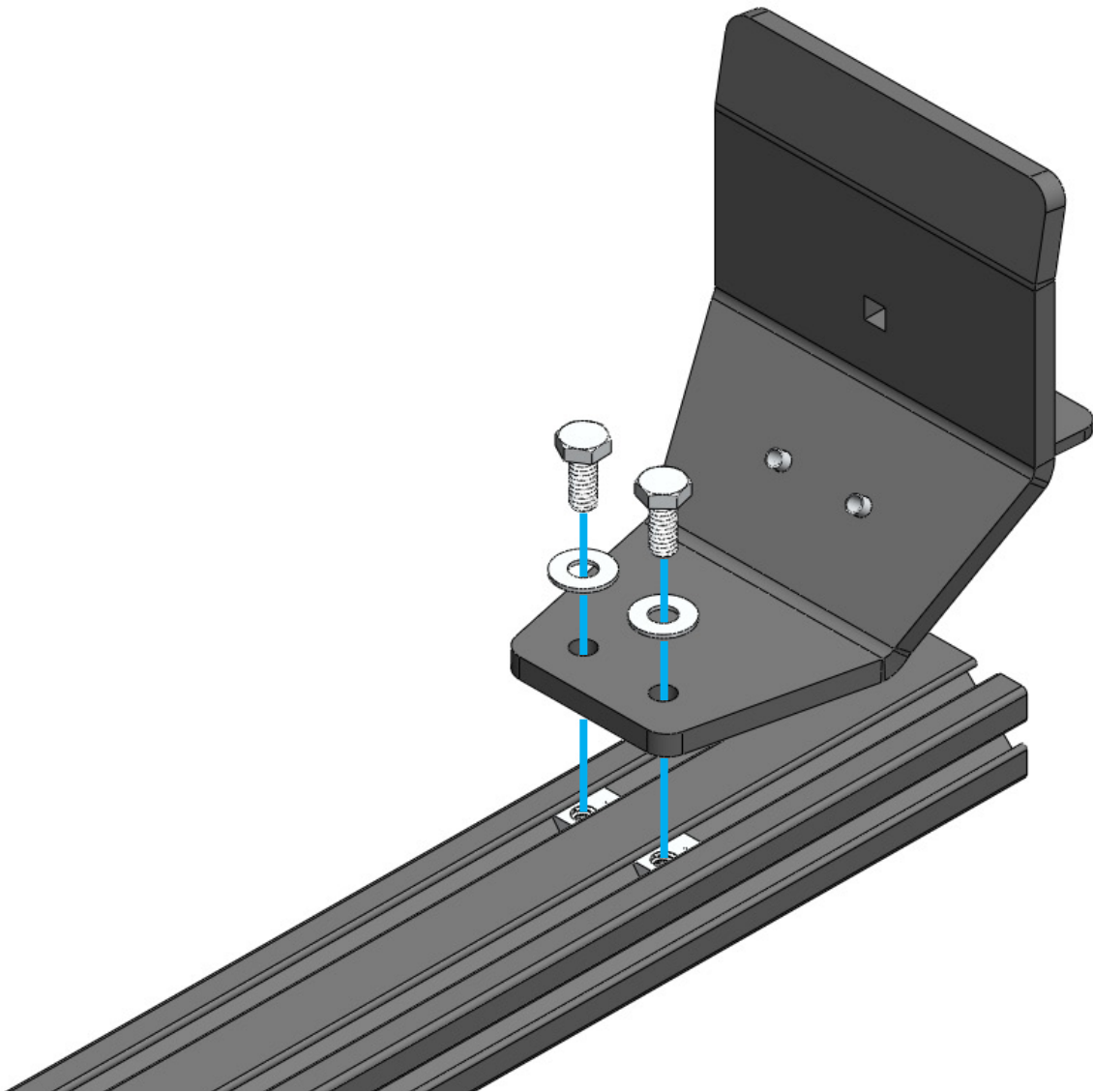

MOUNT ASSEMBLY 02

Required Components:

16x 1/4"-20 x 9/16"

16x 1/4" Flat Washers

16x 1/4" Tnuts

Secure the tops of the mounting brackets to the wide faces of the crossbars using the supplied T-nuts, 9/16" hex bolts, and flat washers.

Leave the hardware that attaches the mount to the crossbar loose. This will make it easier when placing the rack on the truck.

ROOF DIAGRAM

The image below can be used as a guide on where the mounts sit in relation to the vehicle, which ensures the best fitment and functionality of the rack.

Notice that the mounting brackets are not all the same. Your rack should include the following mounts:

- 1x Front Left-side Mount (F L)
- 1x Front Right-side Mount (F R)
- 4x Middle Mounts (M)
- 1x Rear Left-side Mount (R L)
- 1x Rear Right-side Mount (R R)

The mounts will have their respective markings on the top flange.

The outer clamping component is the same for all eight of the mounts.

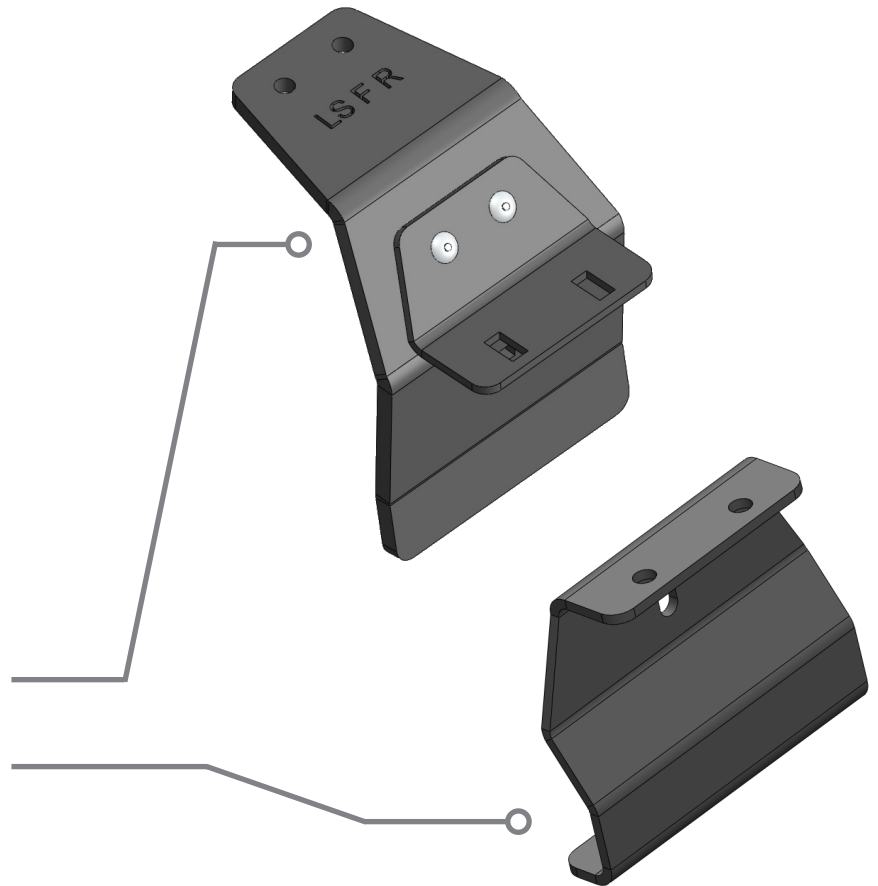

The [measurements](#) below are approximate. Final placement of the mounts will result from where the fairing and sideplates best fit on the vehicle.



MOUNT ASSEMBLY 03

With the mounting assemblies still loosely attached to the crossbars, place the edge-trimmed mounting foot into the rain gutter channel above the doors of the vehicle according to the diagram in the previous step. The outer clamp should sit loosely over the outside of the rain gutter.

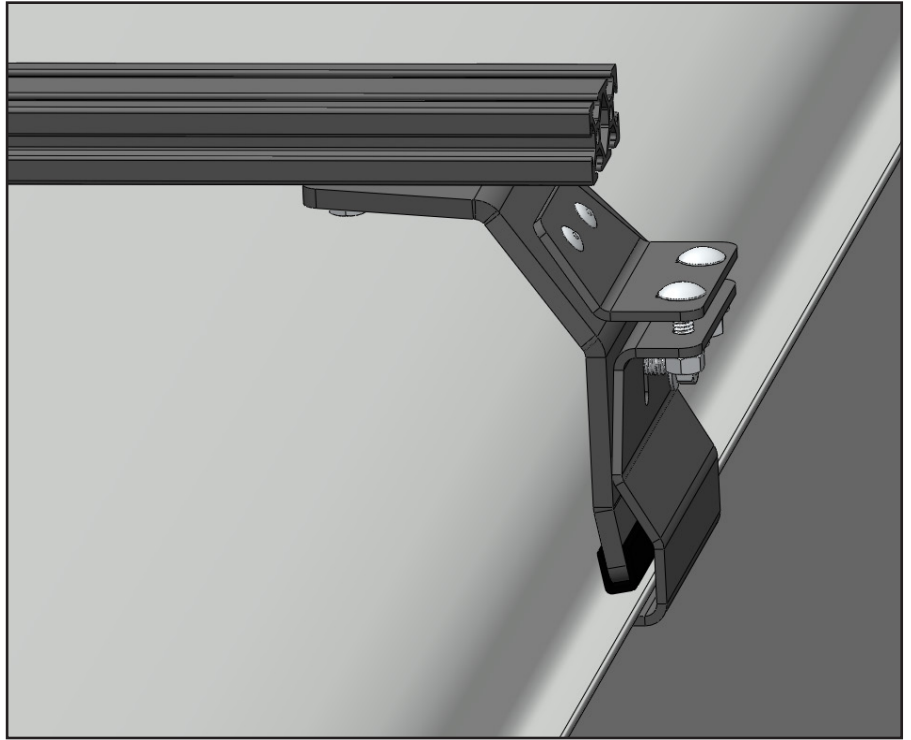

MOUNT ASSEMBLY 04

Center each of the four crossbars on the roof by measuring the **distance from the ends of the crossbar to the inside-edge of the mounting brackets** on either side of the vehicle. Slide the crossbar side-to-side in relation to the mounts until all are centered. Tighten the 1/4"-20 x 9/16" hex bolts on the underside of the mounting feet to secure the crossbars to the feet.





SIDEPLATES

Required Components:

16x 1/4"-20 x 1" Socket Button

16x 1/4" Flat Washer

Fasten the sideplates to the ends of the four mounting-foot crossbars using the supplied 1" socket buttons and flat washers in the designated mounting slots.

Move the sideplate to the position where it best matches the curvature of the vehicle's roof. Installation of the wind fairing, which is outlined later in the installation guide, is a good way to ensure that the rack is placed in the correct location on the vehicle.

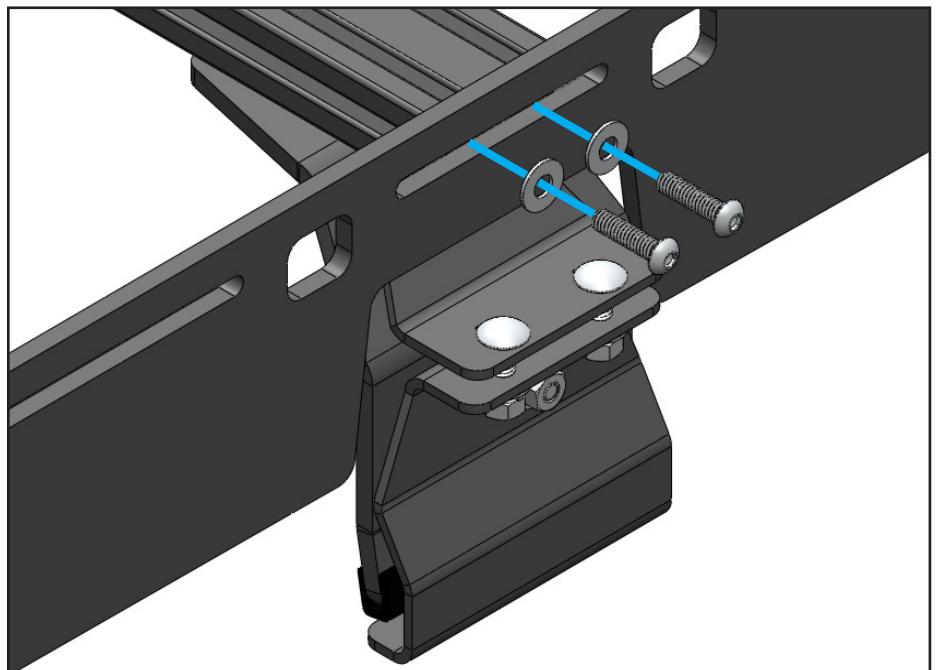

MOUNT ASSEMBLY 05

Once the rack is in its final resting location, tighten down the hardware on the mounts. The following steps will ensure the brackets are properly installed and **not overtightened**. For more clarity, it may be helpful to watch the installation video available on Sherpa Equipment Co.'s website.

1. Get the horizontal set of hardware finger tight. The outer clamping component should sit flat against the inner mounting foot.

2. Begin tightening the vertical sets of hardware until the **bottom flange** of the outer clamping bracket is firmly mounted against the bottom surface of the rain gutter channel. The nuts will only be **finger-tight** when properly installed - the split washer will resist loosening over time.

Also note that when installed, the two flanges between the outer clamp and the inner mounting foot will **not touch**. This is by design.

3. Completely tighten the horizontal hardware. This can be torqued all the way and is less prone to being overtightened.

4. Double check the vertical hardware. Overtightening these can bend parts or cause the rivets in the mounting feet to fail. All components at this stage should be rigidly mounted.

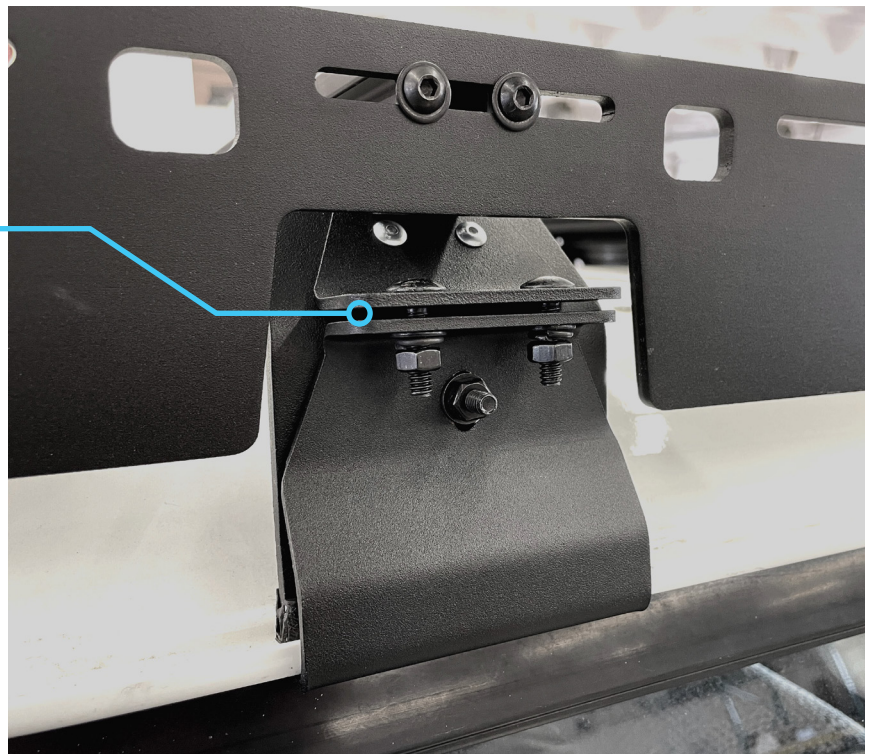

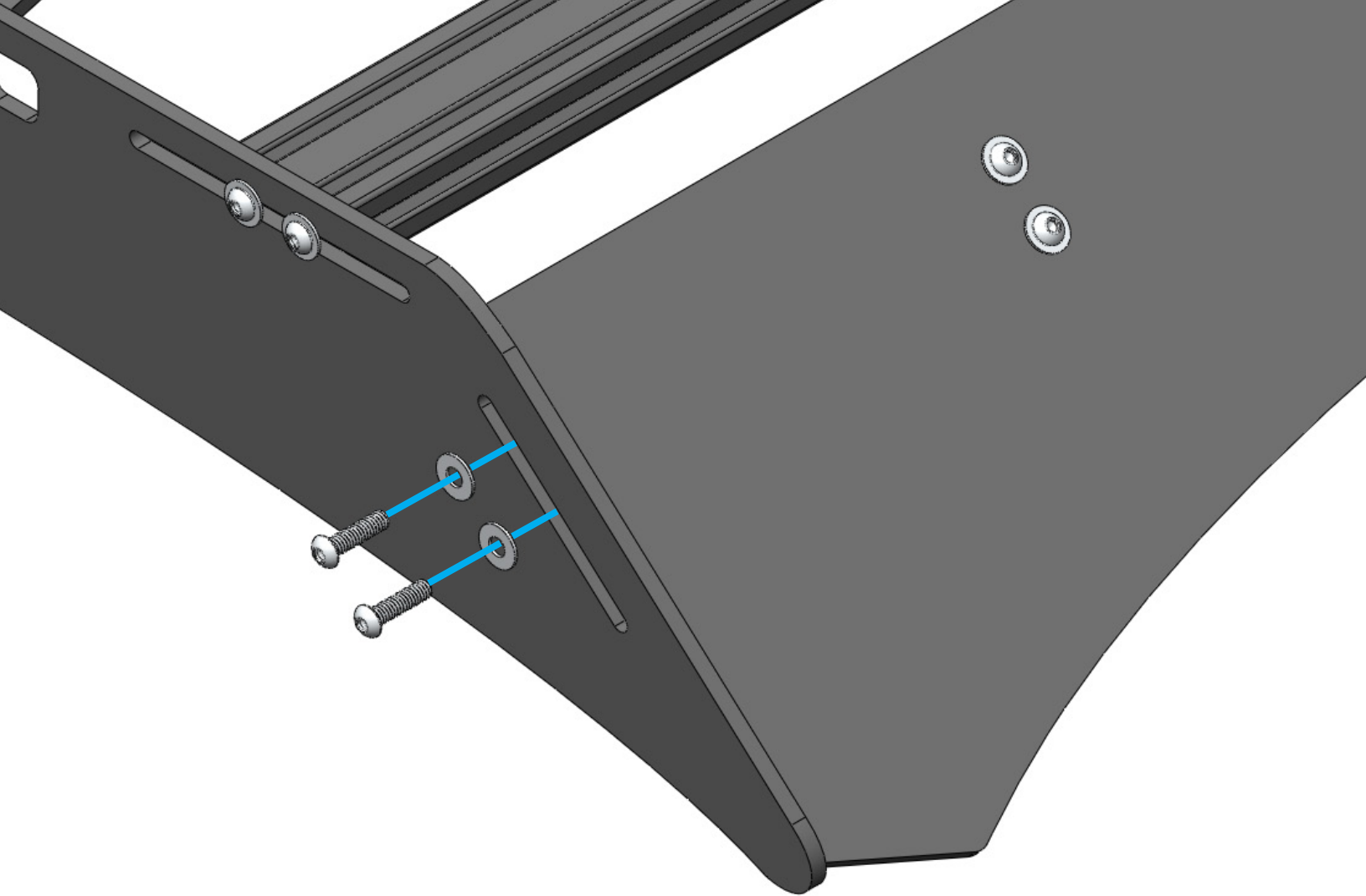

WIND FAIRING

Required Components:

4x 1/4"-20 x 1" Socket button

4x 1/4" Flat Washers

Position the wind fairing in line with the diagonal slot at the front of the rack. Align the corner edge of the fairing with the tip of the roof rack and secure it using four 1" socket buttons and washers. Note that the wind fairing is NOT intended to sit on the vehicle's roof - a small gap of 1/8" - 1/4" is ideal.

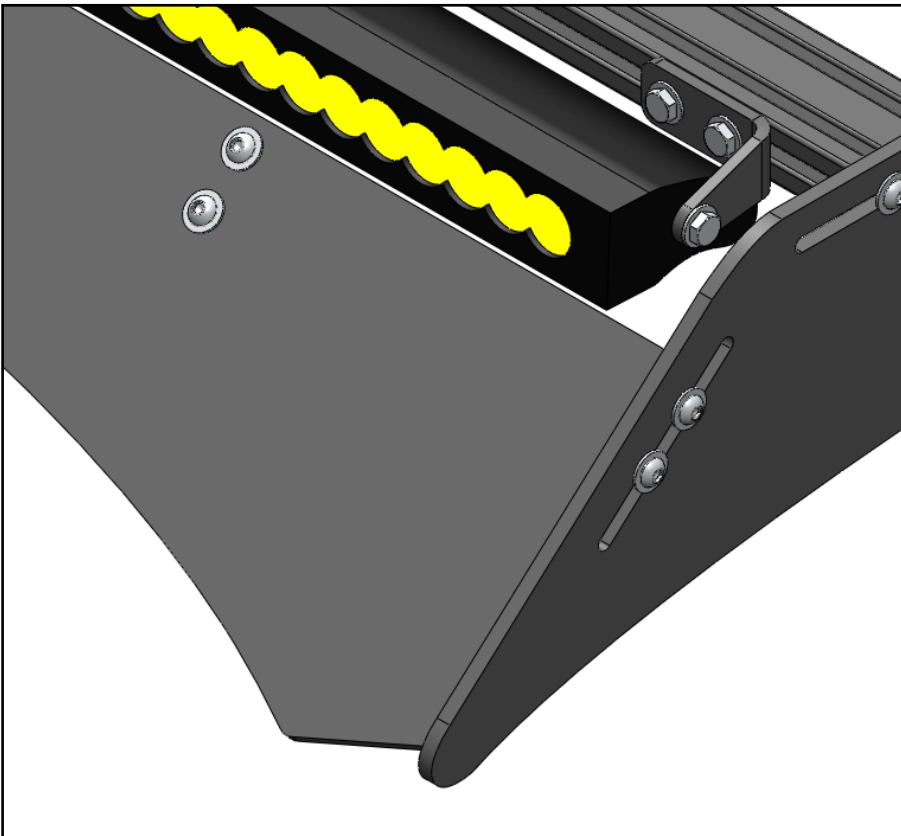

CROSSBARS

Required Components:

20x 1/4"-20 x 1" Socket Buttons

20x 1/4" Flat Washers

5x 52" Crossbars

Secure all of the remaining crossbars to the rack system using the 1" socket buttons and washers in the open slots in the sideplate. Position according to your load requirements.

Half fairing for lightbar applications.

EXPLORE.



All products built and designed by Sherpa Equipment Company are intended for off-road use and should be assembled, installed, and used according to Sherpa Equipment Company's recommendations. Sherpa Equipment Companies products should be used safely with good judgment towards others and surroundings.

By installing Sherpa Equipment Companies products on your vehicle you assume all liability. Sherpa Equipment Company will not be held liable for damages or loss associated with the installation or use of its products. It is recommended that you inspect your roof rack within the first 100 miles of installation and every 500 miles after.