









RACK - HEIGHT PAK 2005-2023 TACOMA

I N S T A L L I N S T R U C T I O N S

HARDWARE CHECKLIST

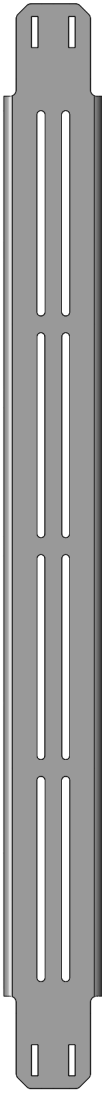
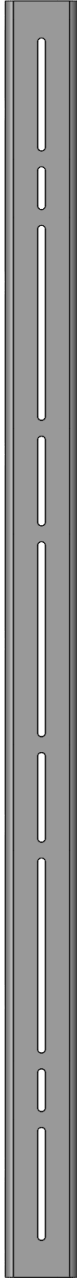
Quantities marked in blue may be used in the preassembly of front adjustable mounts.
Exact hardware color counts may vary based on the options selected at checkout.

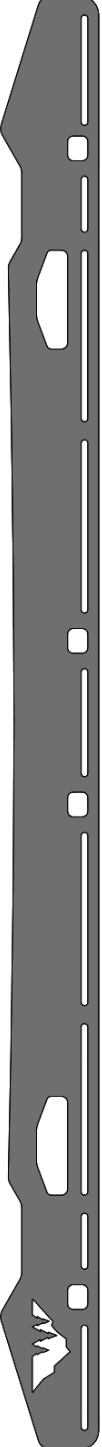
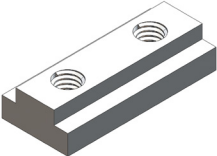
| | | | | | | | | |
|--|---|---|---|---|---|--|--|--|
| 8 | 40 | 2 | 28 | 2 | 8 | 40 | 40 | |
| Hex bolt (3/8"-16 x 1") | Carriage bolt (5/16"-18 x 1") | Carriage bolt (1/4"-20 x 1") | Socket Button (1/4"-20 x 1") | Socket Button (1/4"-20 x 3/4") | 3/8" Flat washer | 5/16" Flat washer | 1/4" Flat washer | |
|  |  |  |  |  |  |  |  | |
| 2 | 40 | 10 | | | 2 | 2 | 5 | 2 |
| 1/4" TNUT | Nylock nut (5/16"-18) | Nylock nut (1/4"-20) | | | ACCESSORY BRACES | CROSSBARS | CROSSBARS (EXTRUSION) | SIDEPLATES |
|  |  |  | | |  |  |  |  |
| 4 | 4 | 4 | | | | | | |
| RACK-HEIGHT TOWERS | CHAIR BRACKETS | BEDNUTS | | | | | | |
|  |  |  | | | | | | |

The below assembly images may differ slightly in appearance from actual product.

01

Required Components:

4x Rack-height towers

4x Chair brackets

16x 5/16"-18 Carriage Bolt

16x 5/16" Washer

16x 5/16"-18 Nut

Loosely fasten each chair bracket to a tower using the supplied carriage bolts, washers, and nylock nuts. Leave the hardware loose enough for the chair brackets to move.

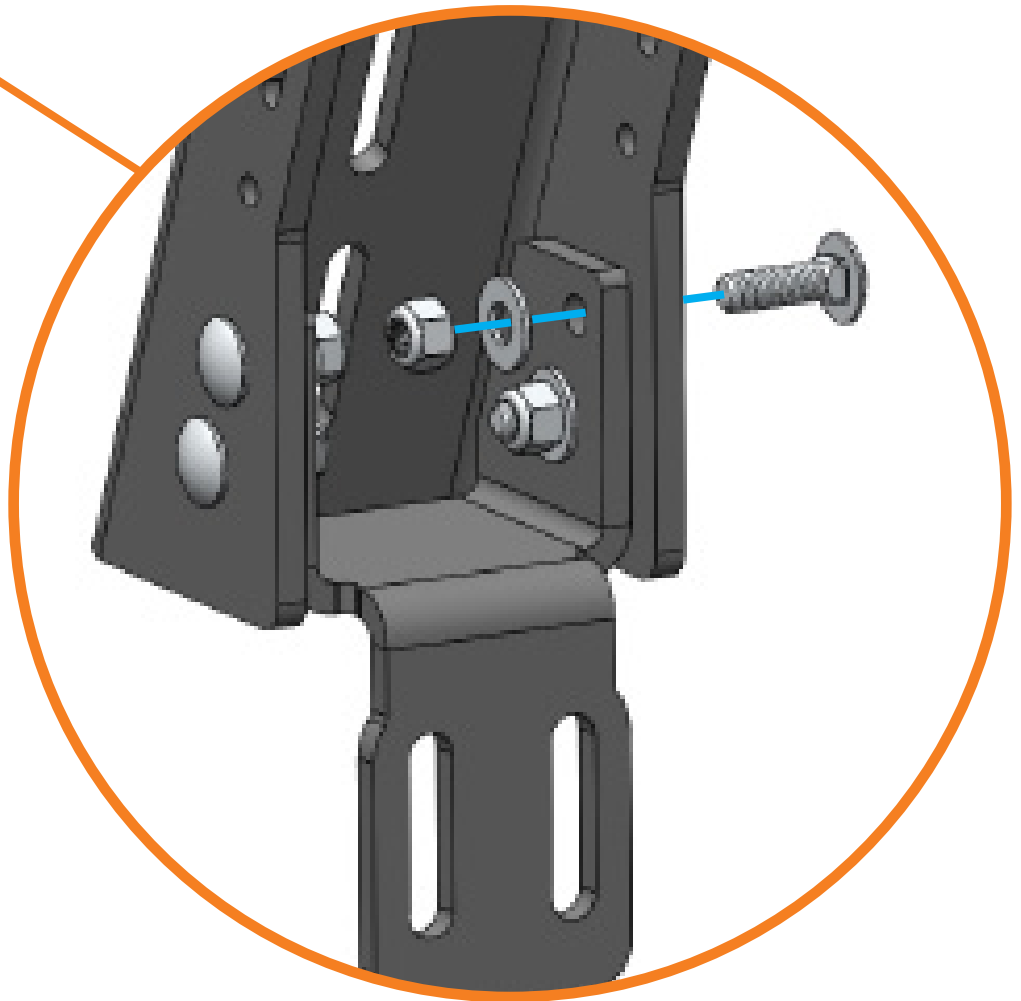
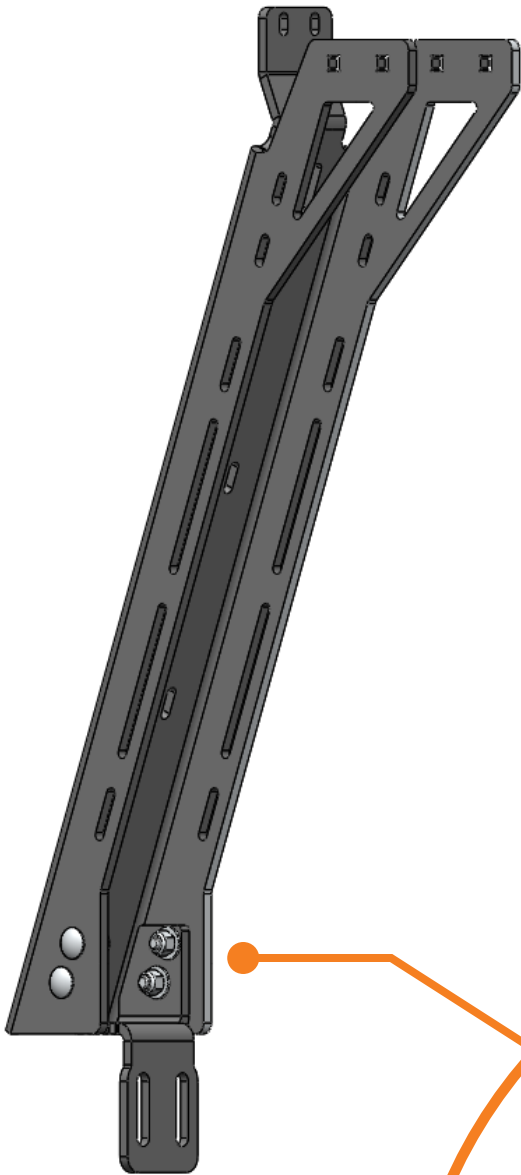

x4

02

Required Components:

4x Bed nut

Remove (or move) any existing accessories or tie-down points in the factory bed rail and insert two of the supplied bed nuts per rail. Space these approximately 42" apart along the length of the rail.

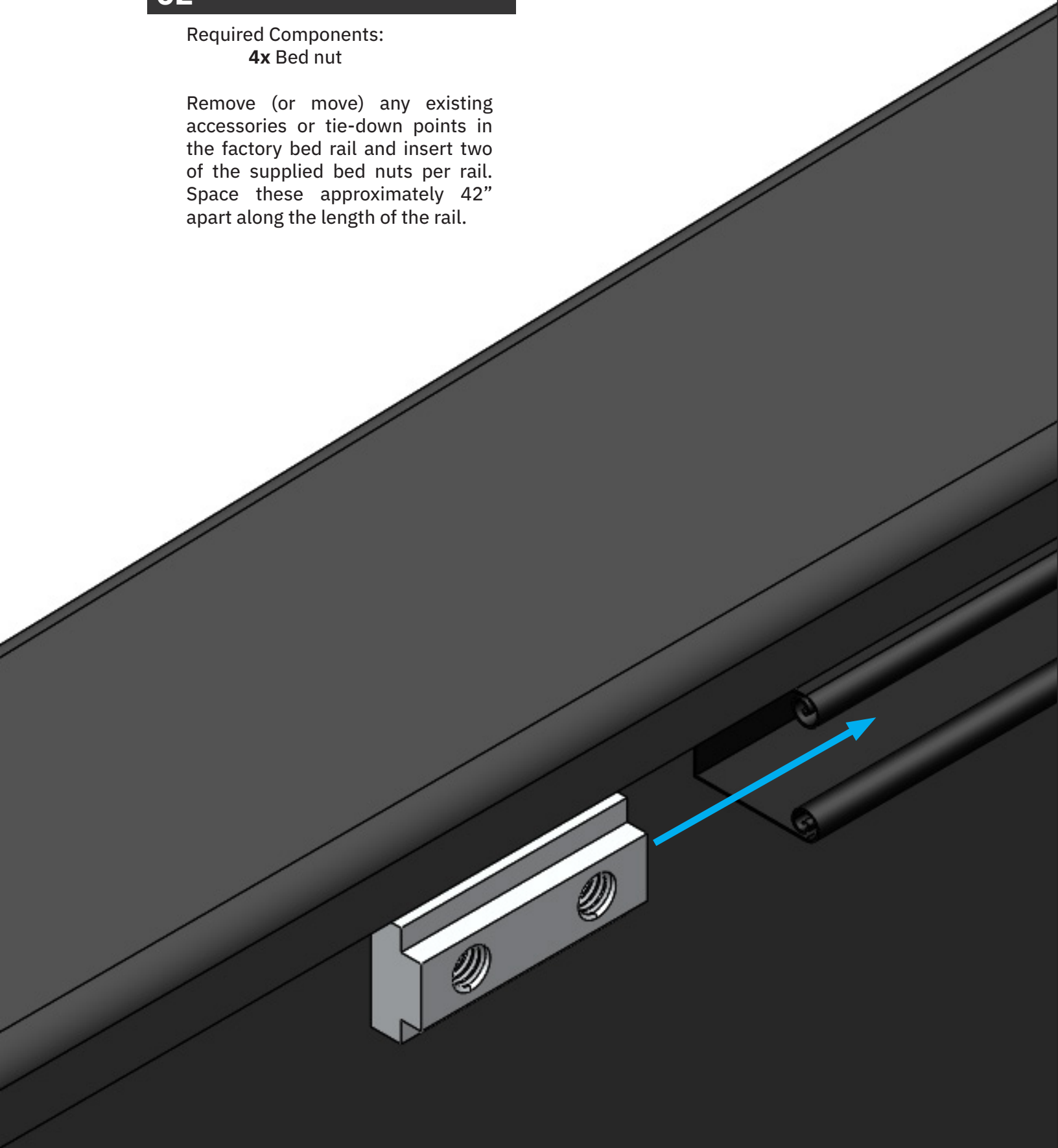

x4

03

Required Components:

8x 3/8"-16 x 1.0 Hex bolt

8x 3/8" Flat washer

Fasten each tower to the factory bed rail by **bolting through the chair brackets into the bednut** using the supplied 3/8"-16 x 1.0" hex bolts and corresponding washers.

With the towers sitting flat on the surface of the bed, **finish tightening** the 5/16" nylock nuts from step 01.

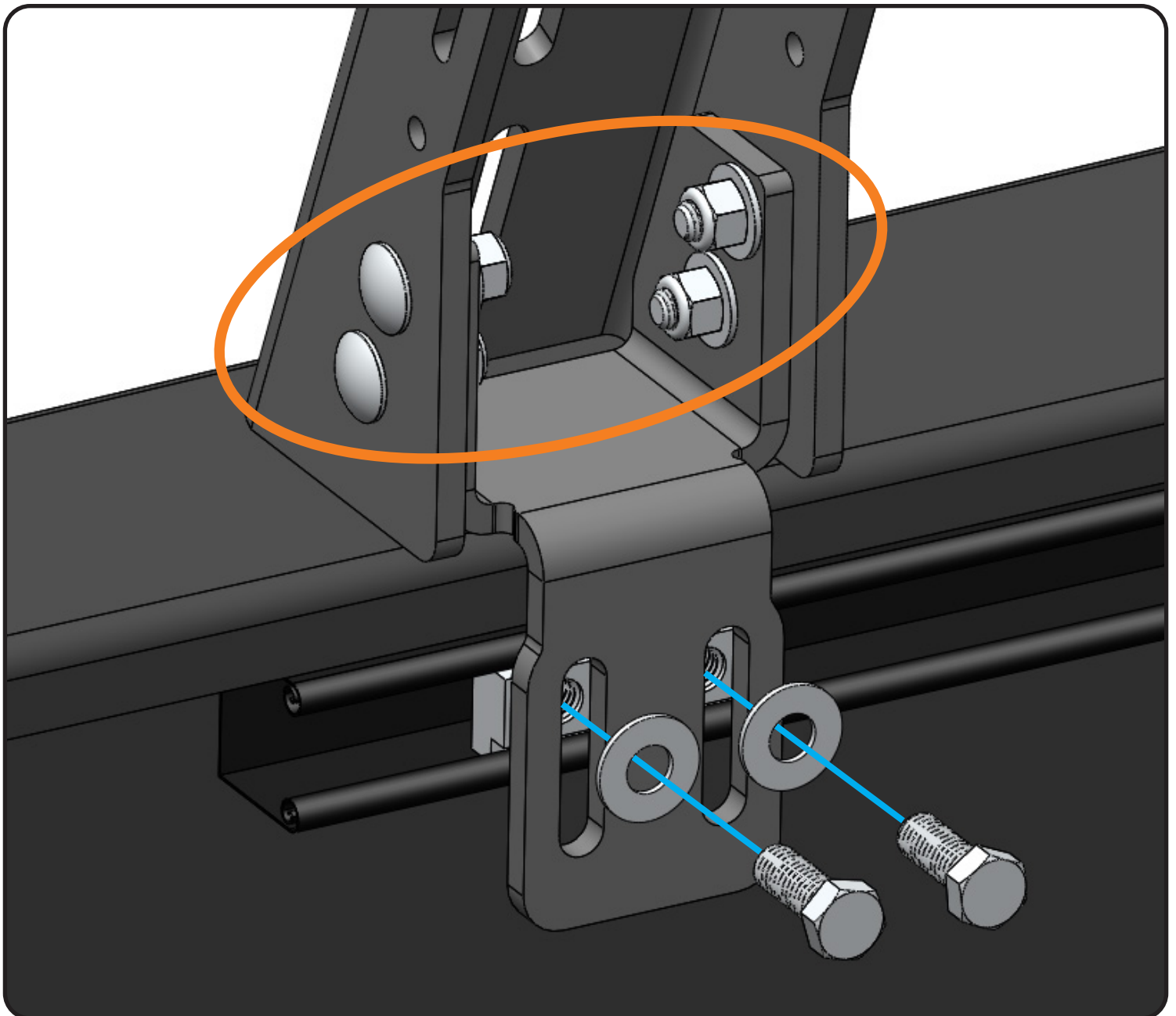

04

Required Components:

16x 5/16"-18 Carriage bolt

16x 5/16"-18 Nylock nut

16x 5/16" Flat washer

Insert a crossbar between the towers. Center the crossbar by measuring and matching the distance between the ends of the bar with the upward-facing flanges of the towers on either side. Fasten with the supplied carriage bolts, washers, and nylock nuts.

For flush installations, use the **top set of mounting slots**. For tents, use the **lower set of slots** to raise the crossbars by 1".

Repeat this for the second set of crossbar and towers.

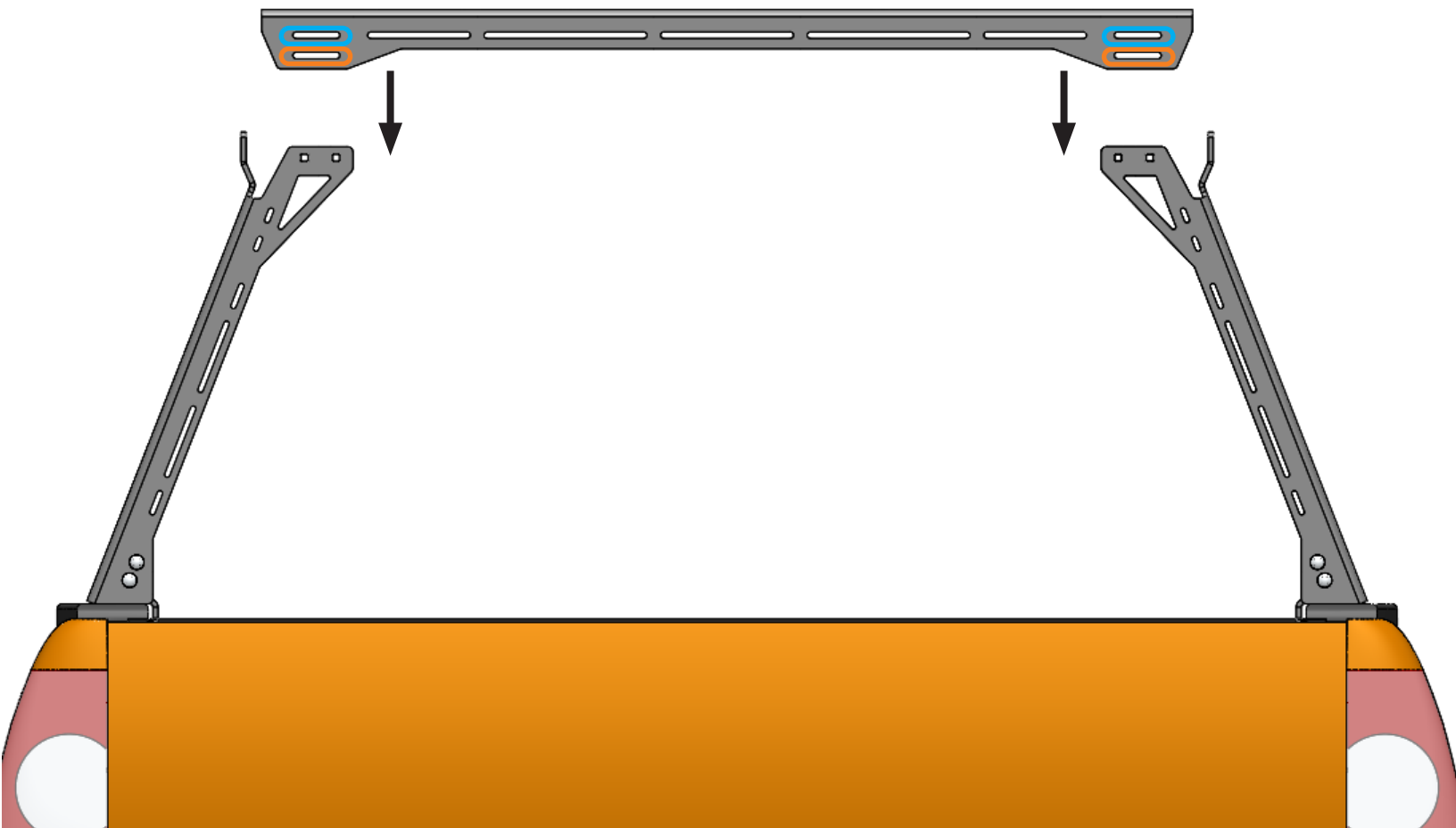

05

Required Components:

8x 1/4"-20 Socket button

8x 1/4"-20 Nylock nut

16x 1/4" Flat washer

Fasten the sideplates to the towers using the supplied 1/4"-20 x 1" socket buttons, flat washers, and nylock nuts. The towers will measure 38 1/2" apart when measured between the inside faces of the tower.

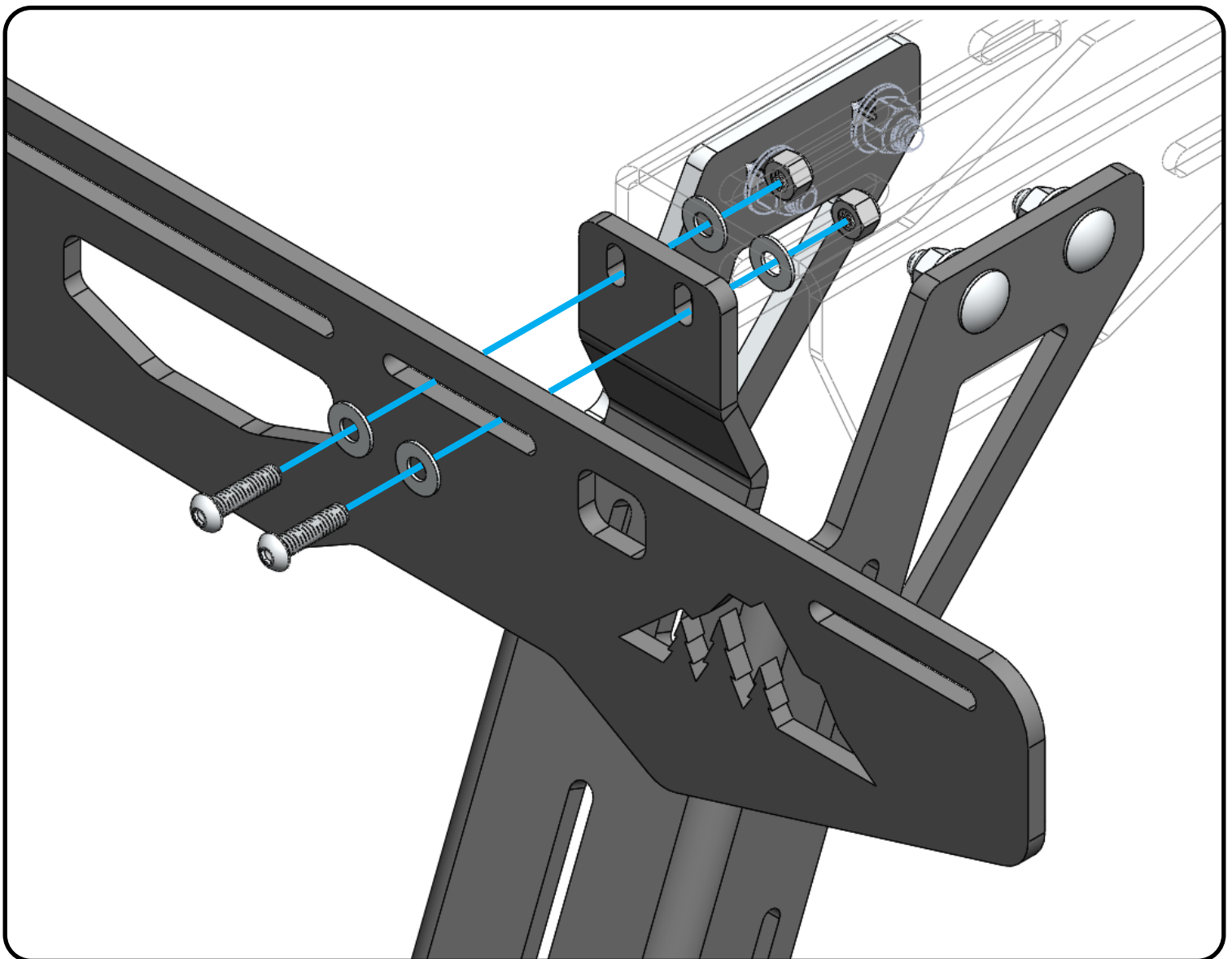
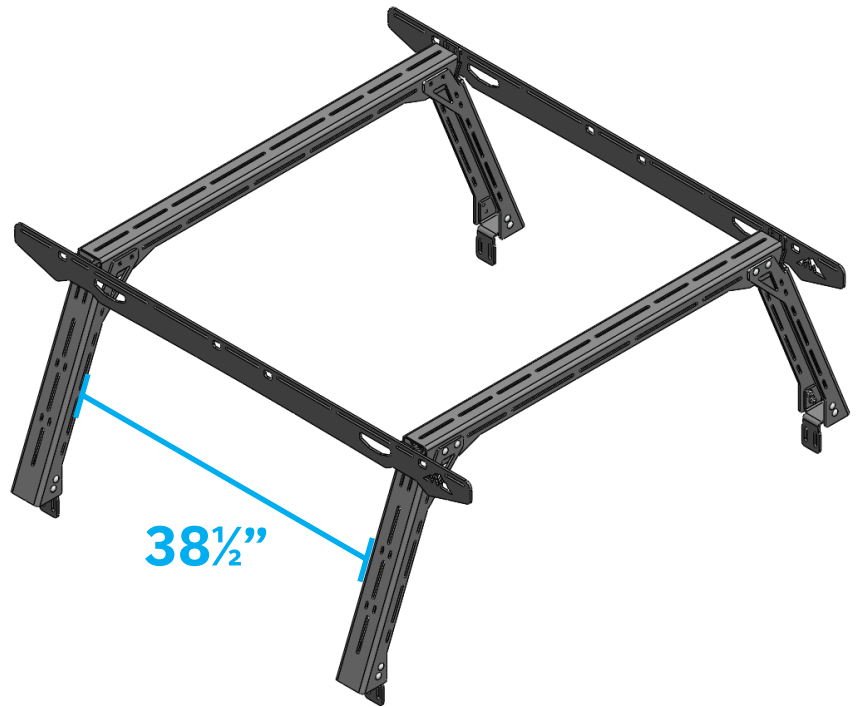

06

Required Components:

20x 1/4"-20 Socket button

20x 1/4" Flat washer

5x Extrusion crossbar

Install the extrusion crossbars to the slots of the sideplates with the included 1/4"-20 socket buttons and 1/4" flat washers. Distribute the bars along the length of the rack as needed.

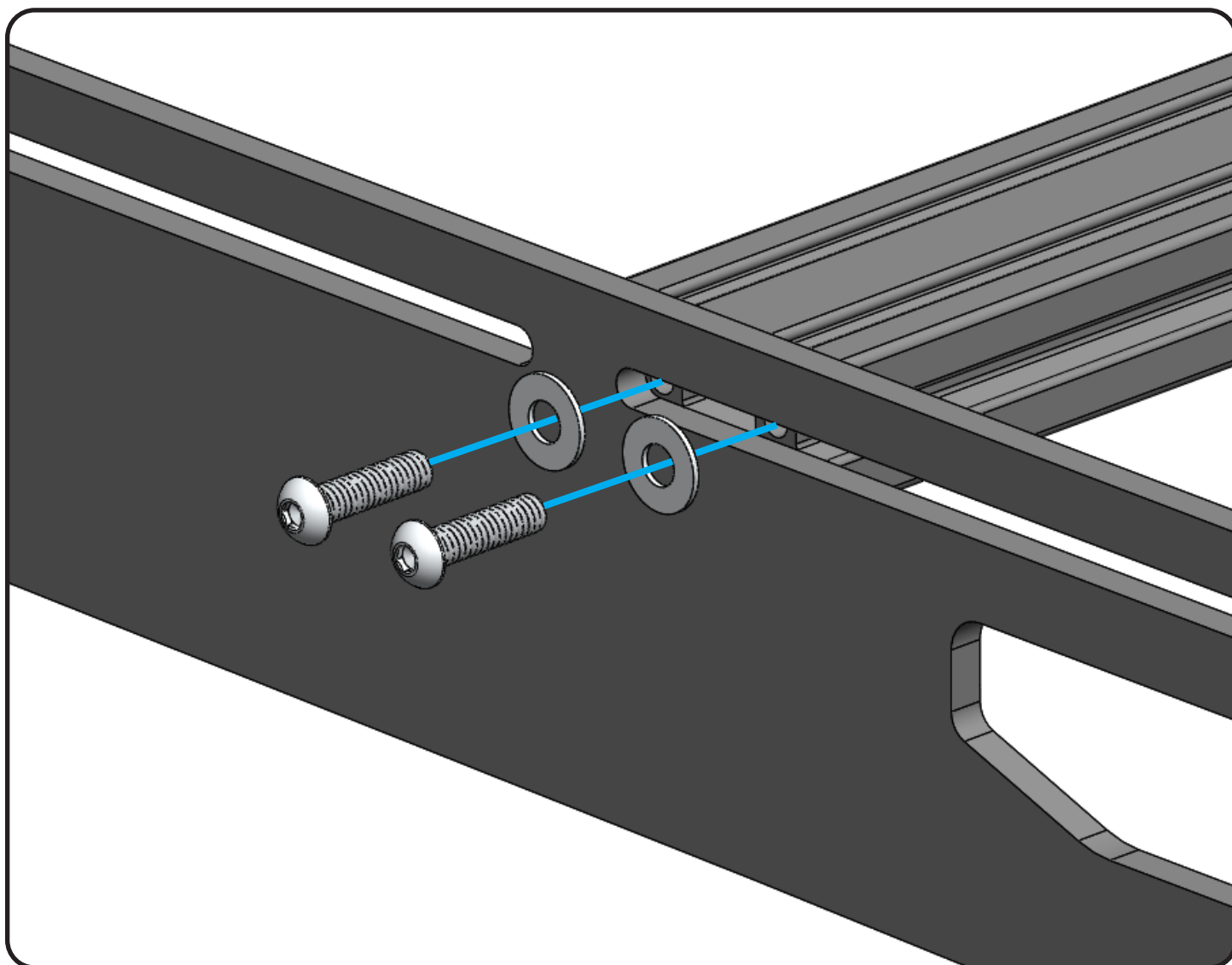

07

Required Components:

8x 5/16"-18 Carriage bolt

8x 5/16"-18 Nylock nut

8x 5/16" Flat washer

Install the accessory braces along the length of the bed rack assembly using the supplied carriage bolts, washers, and nylock nuts.

The same process applies to the installation of the XL accessory panels (optional upgrade).

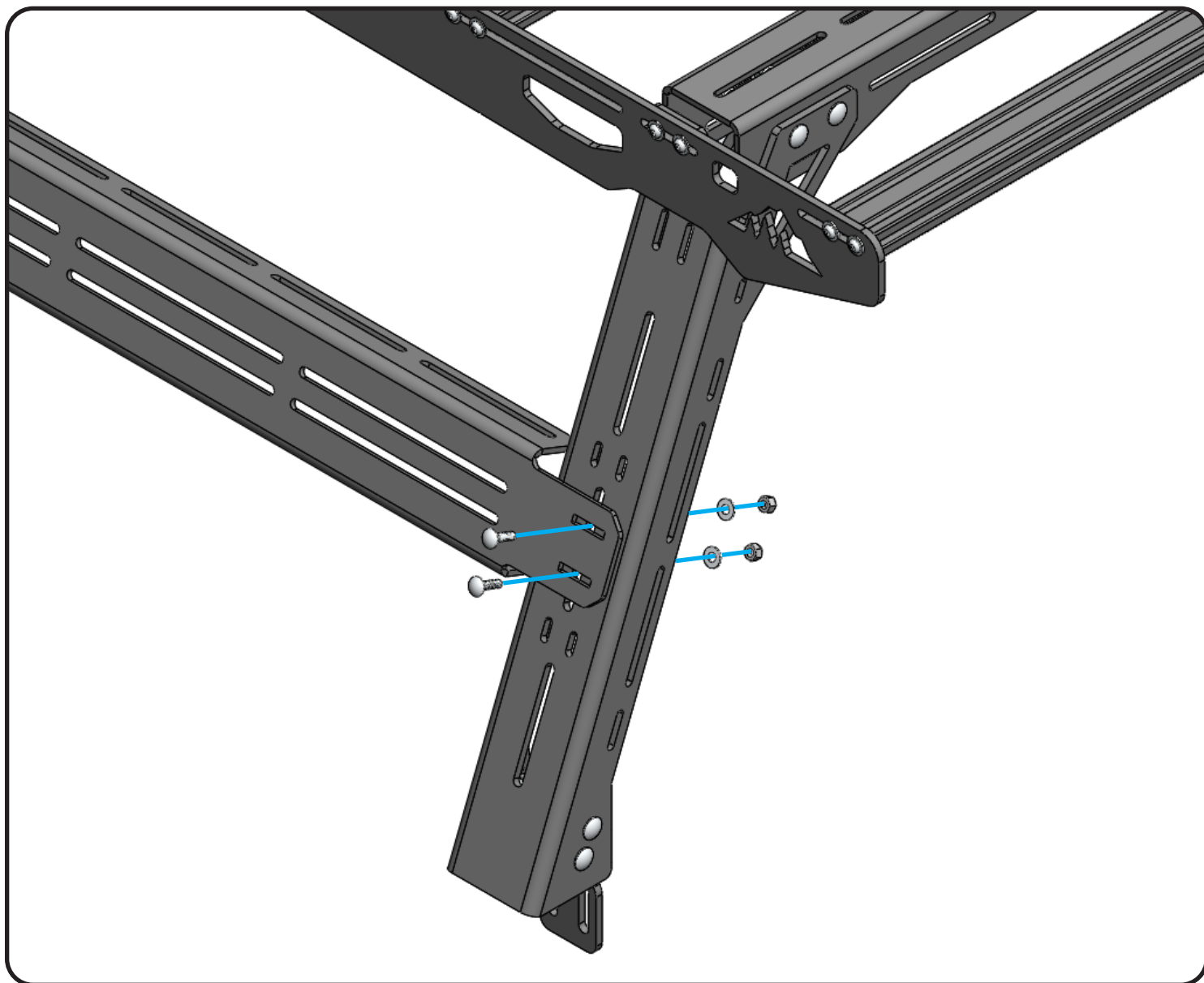



STANDARD



- **XL ACCESSORY PANEL**
- **ROOFTOP TENT**
(Sold separately)

EXPLORE.



All products built and designed by Sherpa Equipment Company are intended for off-road use and should be assembled, installed, and used according to Sherpa Equipment Company's recommendations. Sherpa Equipment Companies products should be used safely with good judgment towards others and surroundings.

By installing Sherpa Equipment Companies products on your vehicle you assume all liability. Sherpa Equipment Company will not be held liable for damages or loss associated with the installation or use of its products. It is recommended that you inspect your roof rack within the first 100 miles of installation and every 500 miles after.