



THE URSA MINOR

I N S T A L L I N S T R U C T I O N S

HARDWARE CHECKLIST

Exact hardware color counts may vary based on the options selected at checkout.

8
3/16"
Rivets



24
1/4"-20
(1")



8
M8
(16mm)



8
1/4"-20
(9/16")



6
1/4"-20
(1/2")



8
M8 Flat
Washer



38
1/4" Flat
Washer



14
1/4" Tnut

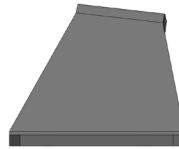

2
FRONT
Mounting
Brackets

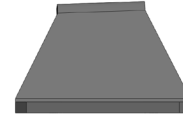

2
REAR
Mounting
Brackets

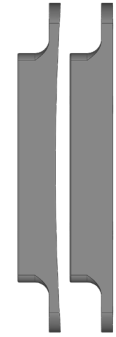

2 Contoured Rivet Spacers
2 Flat Rivet Spacers

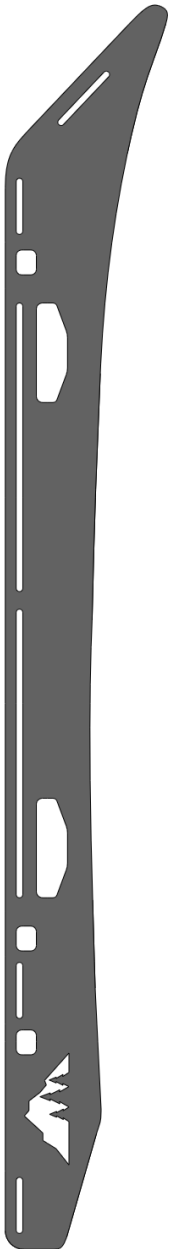

2

Sideplates



6

Extrusion Crossbars

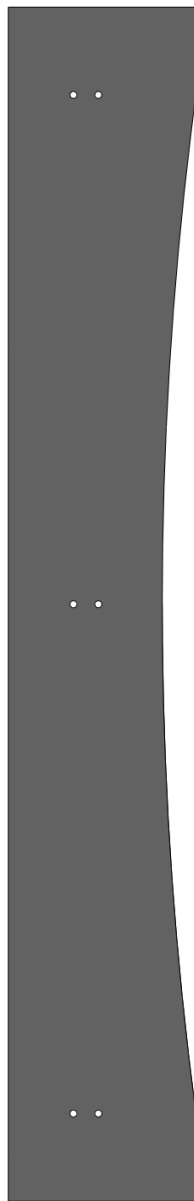

1

Wind Fairing w/ Edge Trim

BEFORE YOU BEGIN

The installation of this rack requires you to drill into your roof. If you are not comfortable with this, please contact a reputable installer.

USING TNUTS

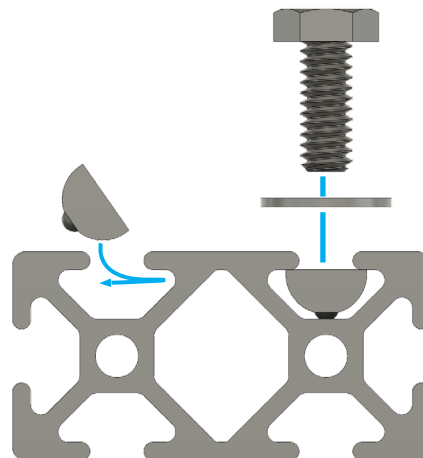

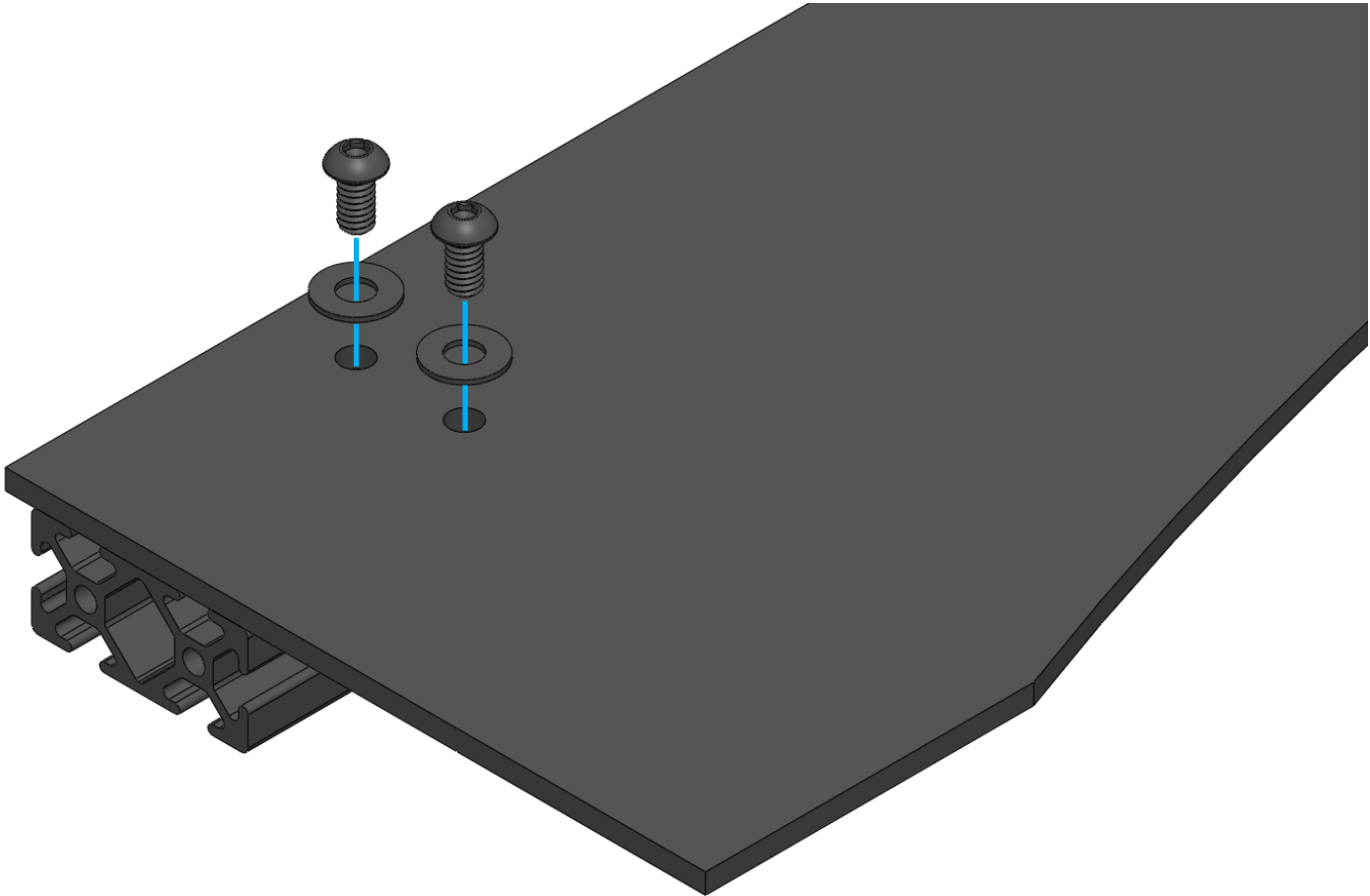

FAIRING ASSEMBLY

Required Components:

6x 1/4"-20 x 1/2"

6x 1/4" Flat Washers

6x Nuts

Drop 6 nuts into the slots on the cross member and line them up with the holes in the fairing. Secure with 6 bolts and washers.



MOUNT ASSEMBLY 01

Required Components:

- 8x** M8 x 16 Hex bolt
- 8x** M8 Flat Washers
- 2x** Rivet Spacer - Contour
- 2x** Rivet Spacer - Flat

Loosely fasten the supplied rivet spacers to the bottom (longer) flange of the mounting brackets using the supplied M8 hex bolts and M8 flat washers. The **contour** spacers go on the front mounting brackets, and the **flat** spacers go on the rear mounting brackets. The brackets are designated with 'F' and 'R', respectively.

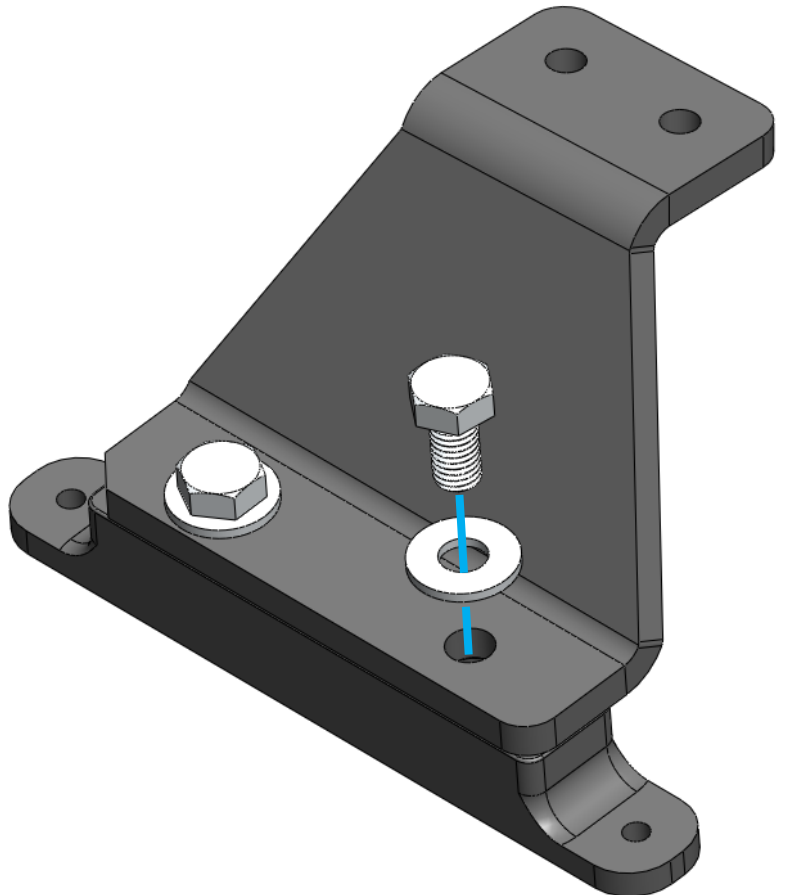

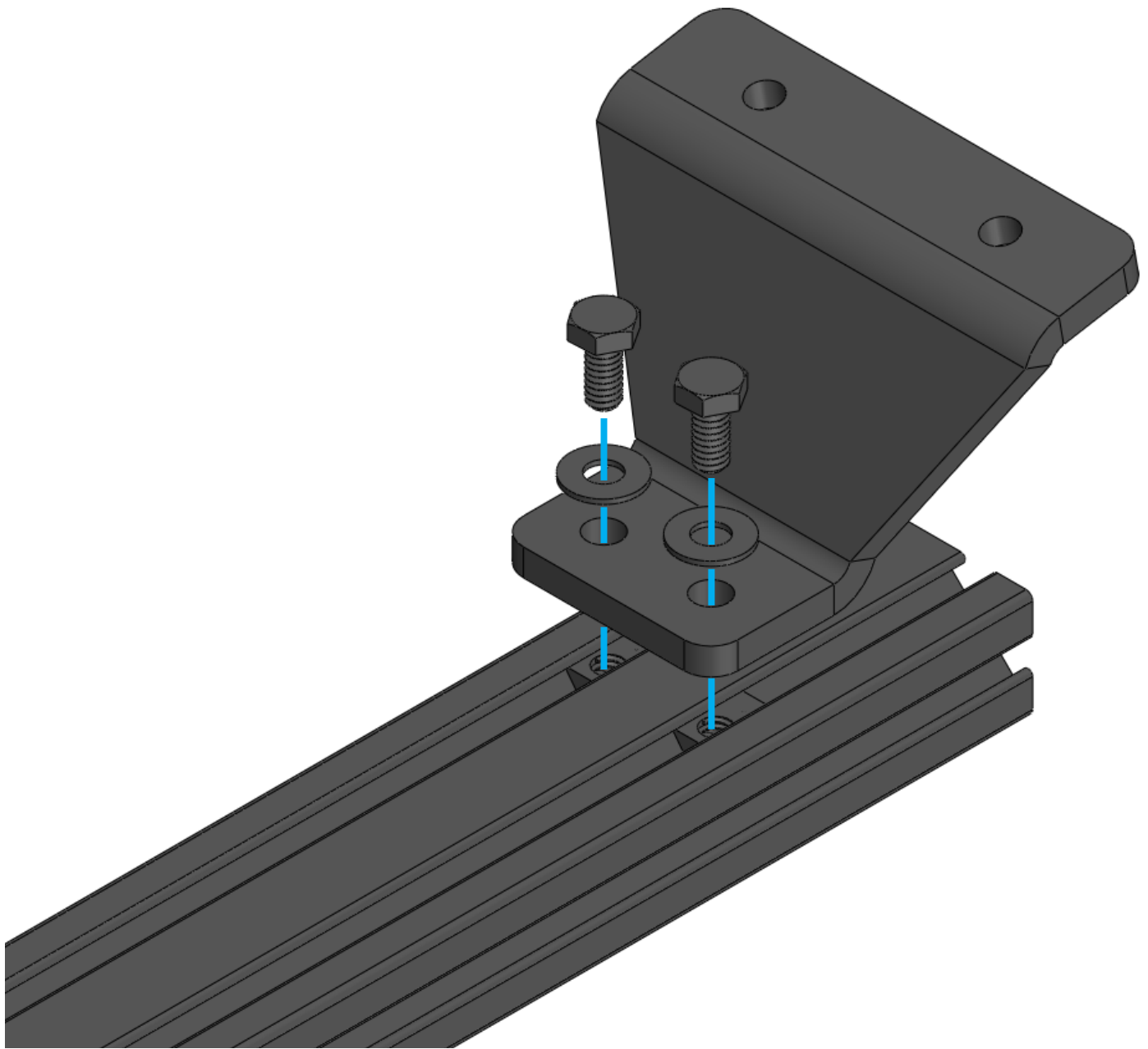

MOUNT ASSEMBLY 02

Required Components:

- 8x** 1/4"-20 x 9/16"
- 8x** 1/4" Flat Washers
- 8x** 1/4" Tnuts

Secure the tops of the mounting bracket pairs to the wide faces of the cross members using the supplied T-nuts, 9/16" hex bolts, and flat washers.

Leave the hardware that attaches the mount to the crossbar loose. This will make it easier when placing the rack on the truck later.

For reference, we have found that the front mounts sit roughly 4.75" from the end of the cross member, and the rears, 4.5".

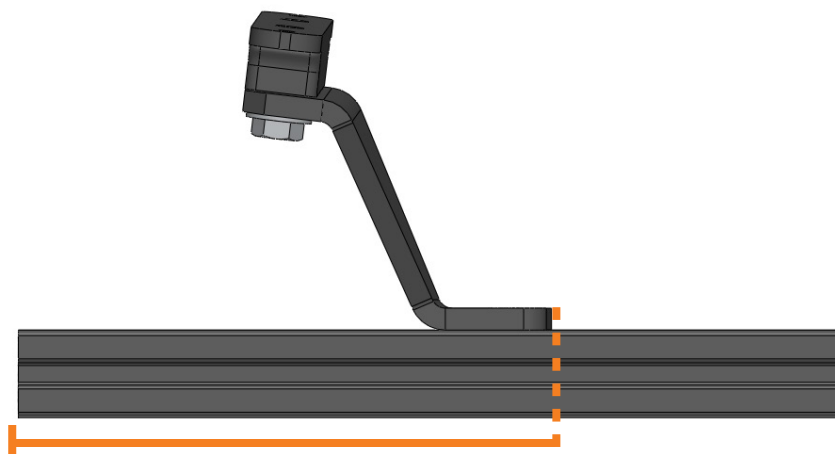

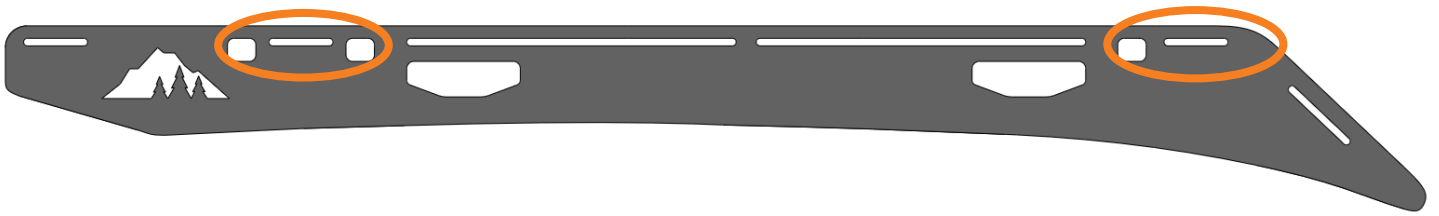

SIDEPLATES

Required Components:

8x 1/4"-20 x 1"

8x 1/4" Flat Washers

Fasten the sideplates to the ends of the two mounting-foot cross members using the supplied 1" socket buttons and flat washers in the **designated mounting slots**, as pictured above. Recall that the brackets come in pairs denoted by the 'F' (front) or 'R' (rear). Note the small notch in the bottom corner of the bracket - this will face toward the front of the vehicle when installed.

The cross member should sit relatively centered in the slot, but may shift slightly due to small variations in roof construction or shifting during the drilling step. More on that later.

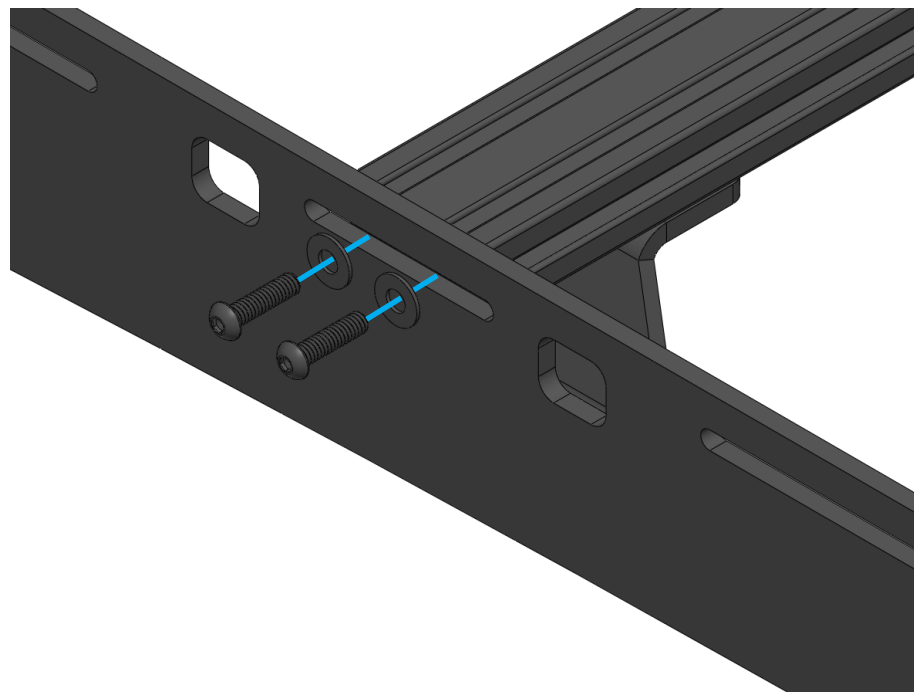
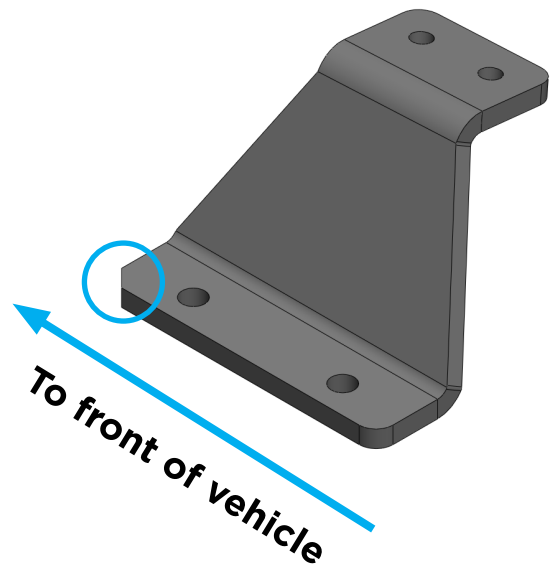



TEMPLATE

Position the assembled rack on the roof of your vehicle. Move the mounting brackets along the cross members so that they sit in the gutters of the roof.

Adjust the brackets along the length of the cross member so that the rivet spacer sits flat and is relatively centered in the gutter. Likewise, the bottom edge of the sideplate should fit nicely along the curvature of the vehicle with a consistent gap of around 1/2". If it does not, move the rack (or cross members in the slot) until the rack looks centered and placed properly.

The properly aligned rack will serve as the drilling template. Follow the next steps to ensure the best fitment of the rack.

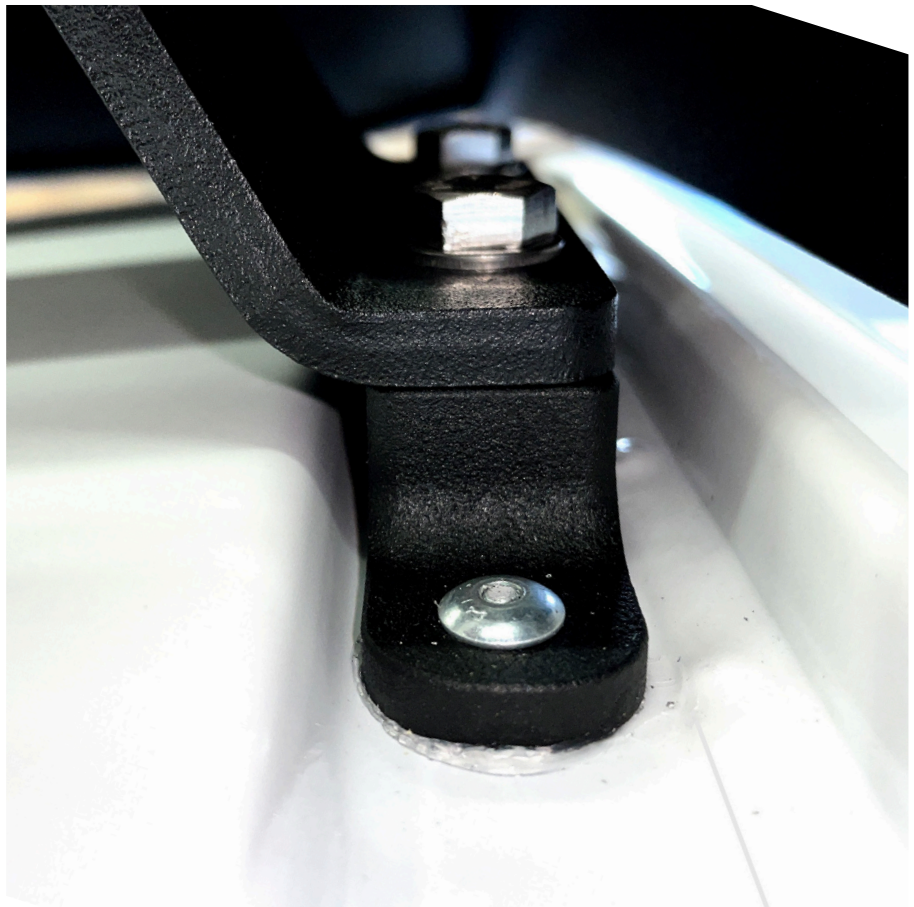

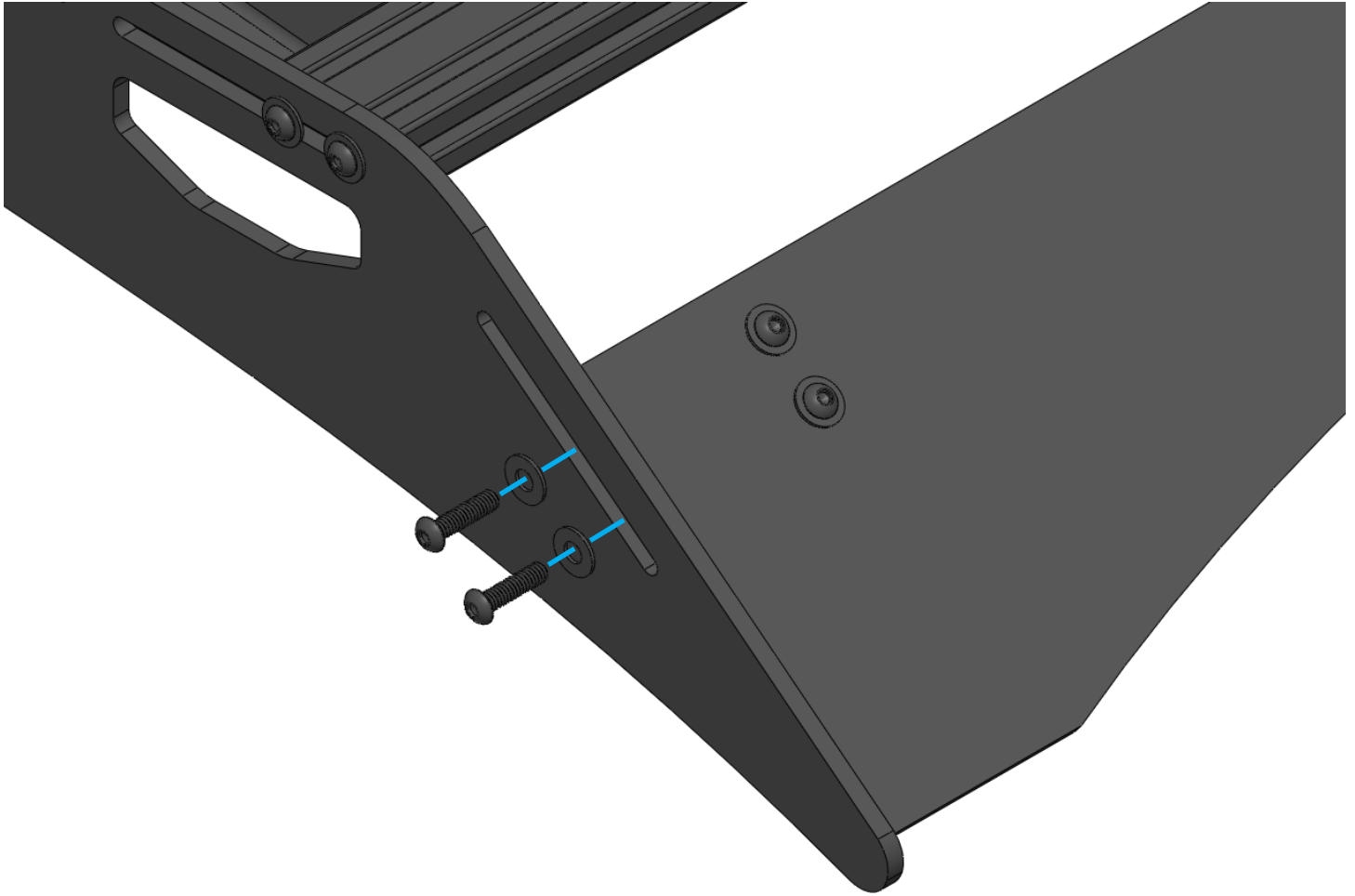

WIND FAIRING

Required Components:

4x 1/4"-20 x 1"

4x 1/4" Flat Washers

Position the wind fairing in line with the diagonal slot at the front of the rack. Align the bottom of the fairing with the tip of the roof rack and secure it using four 1" socket buttons and washers. Note that the wind fairing is NOT intended to sit on the vehicle's roof - a small gap of 1/8" - 1/4" is ideal.

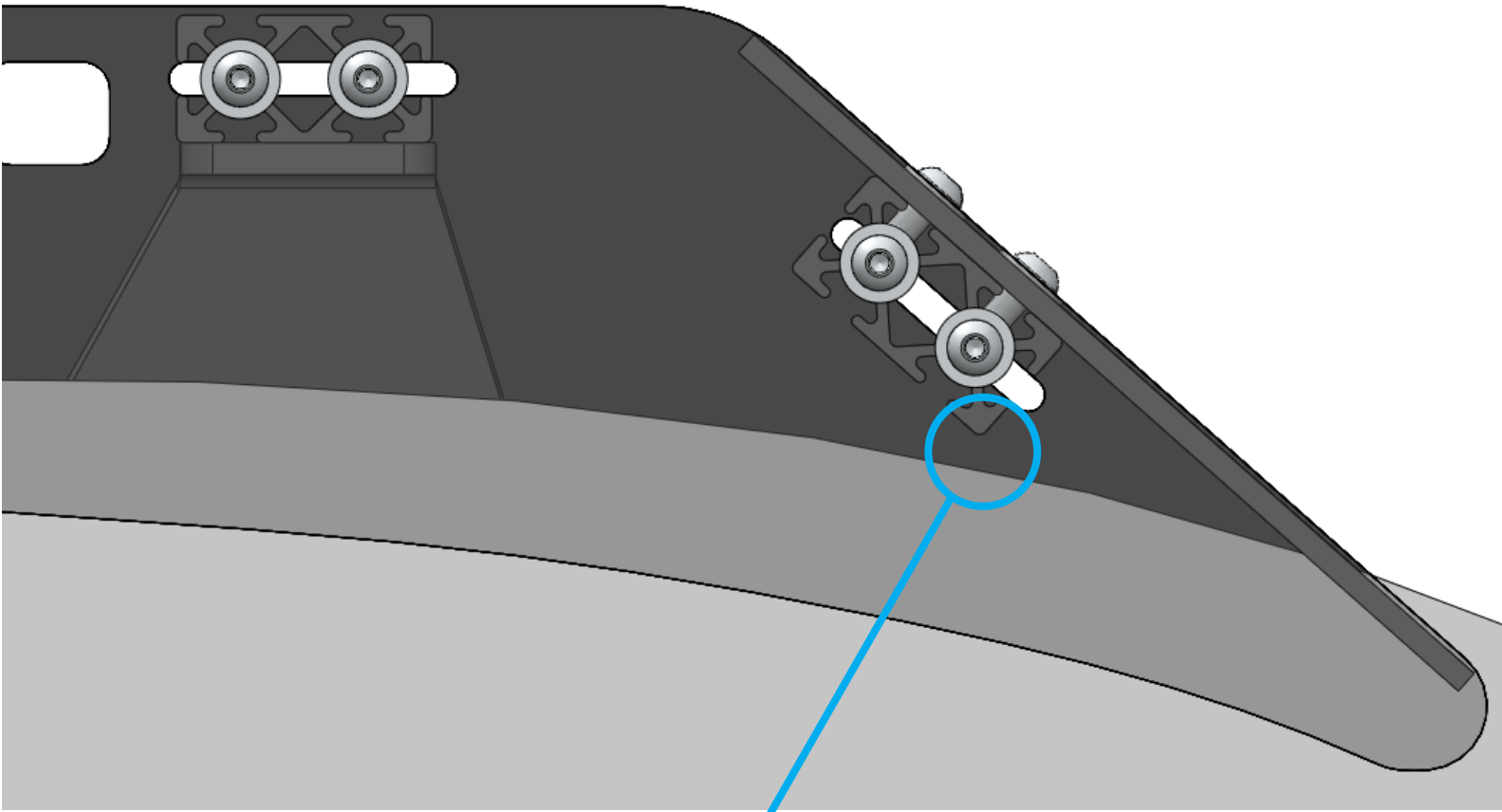

NOTE

For half-sized fairing installations of the Ursa Minor, it is important to note the proximity of the cross member that supports the wind fairing to the roof. If this cross member is touching - or too close to - the roof, the rack can be adjusted by moving the mounting bracket cross members along the designated slots.

This moves the rack forward without changing the rake angle of the rack in relation to the vehicle to ensure the rack is level.

The crossbar sits low to allow for lightbar clearance while maintaining a low profile.

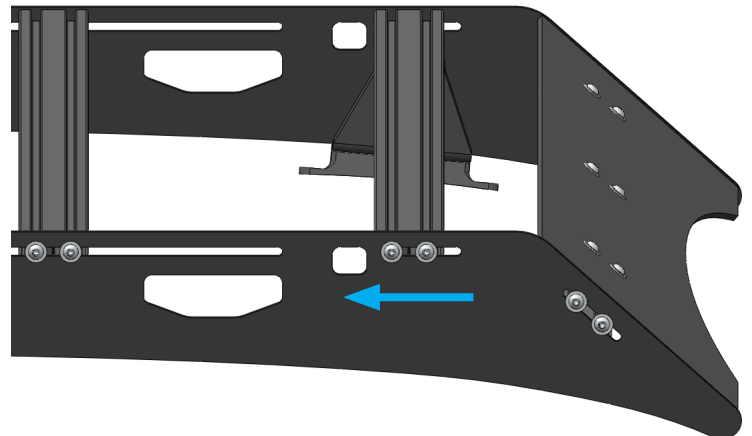
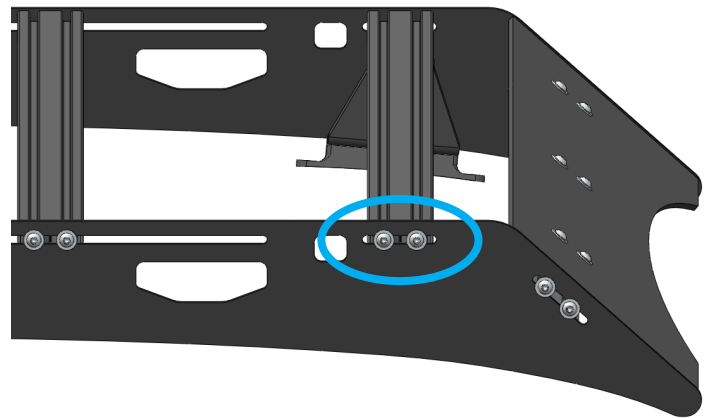

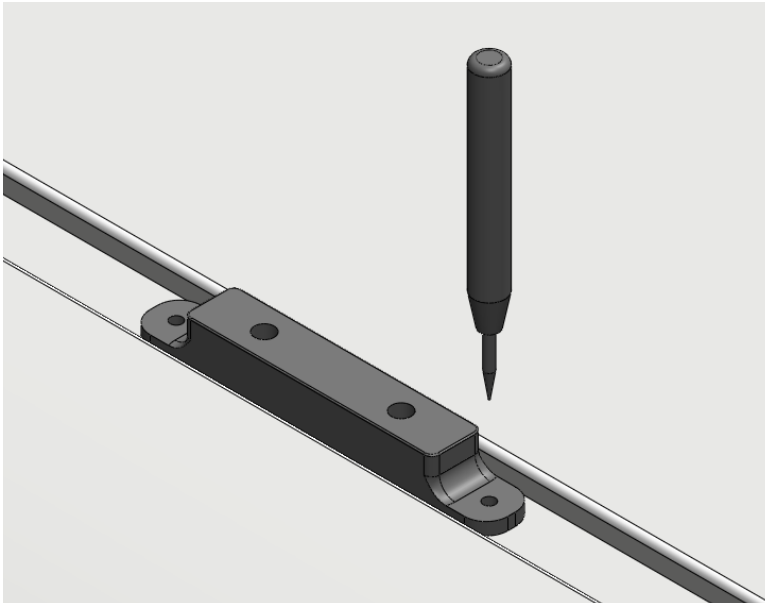

THE NEXT STEPS ARE CRITICAL AND ARE CONSIDERED AN EXPERT LEVEL INSTALL. IF YOU ARE NOT COMFORTABLE DRILLING PLEASE FIND A LOCAL SHOP TO INSTALL YOUR RACK.

DRILLING

Required Tools:

1x Center Punch

1x 3/16" Drill Bit

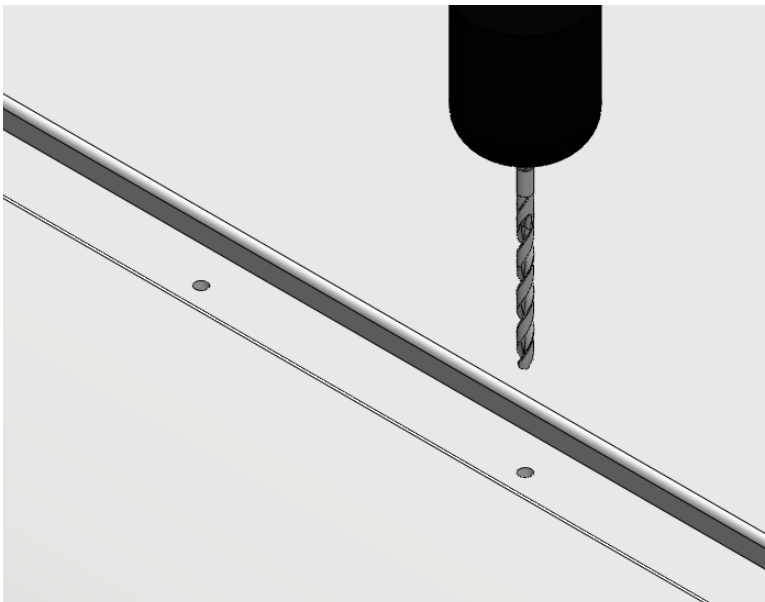

With the rack on the truck, mark the position for each rivet spacer **USING A PUNCH** to create your starting points for drilling. This is important as the drill bit will want to walk away while drilling your pilot holes. The position of these holes are important in making sure that the rack fits your vehicle correctly. **Measure 3 times, check 4 times.** Be extremely careful not to drill through your airbags - using a drillstop on your drill bit can help prevent this by limiting the travel of the drill bit.

With the holes marked, the rack can be removed from the roof. It is worth double checking that the rack sits in its final configuration before marking, removing, and drilling. The rivet spacers can also be removed from the mounting brackets on the rack to assist the following steps.

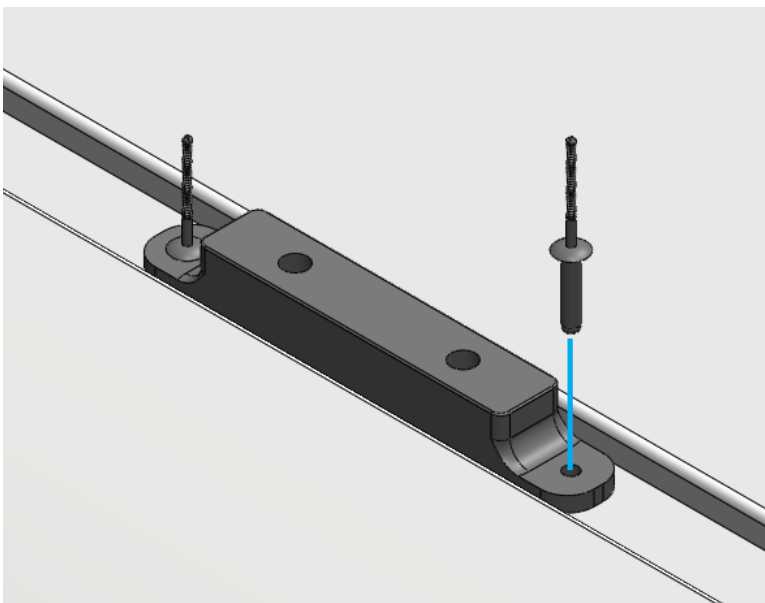

Once you have your drilling points marked with the punch, drill the hole using a **3/16"** drill bit. A pilot hole using a smaller drill bit - such as a 1/8" or 5/32" bit - can be drilled first. **DO NOT** allow the drill bit to plunge after the hole is drilled. The headliner is only a small distance below the surface of the roof. Be sure to keep the drill bit as straight as possible while drilling. **AGAIN, DO NOT** allow the drill bit to plunge after the hole is drilled.

Check that the rivets will pass through the rivet spacer and the drilled hole. A tight fit is preferred in order to solidify the connection between the vehicle and the rack.

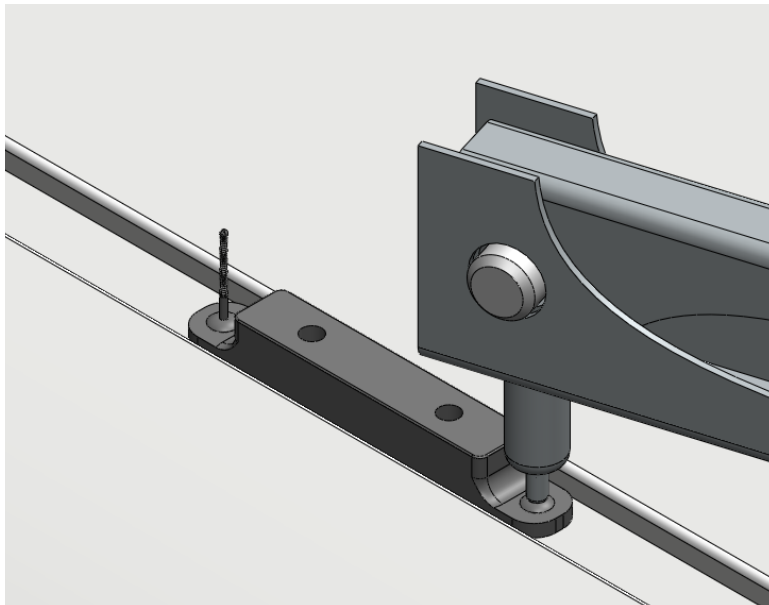

RIVETS

Required Components:
8x 3/16" Rivets
1x Rivet Tool

Next, secure the rivet spacers using the holes you have drilled. It is important that the spacer is tight against the roof and free of debris before riveting it down. Apply a small amount of silicone in and around the rivet spacer and rivet to seal up the hole in the roof. Using your rivet tool, clamp down on the rivet as close to the head as possible. The mandrel of the rivet will shear off once it is installed and should be flush with the head.

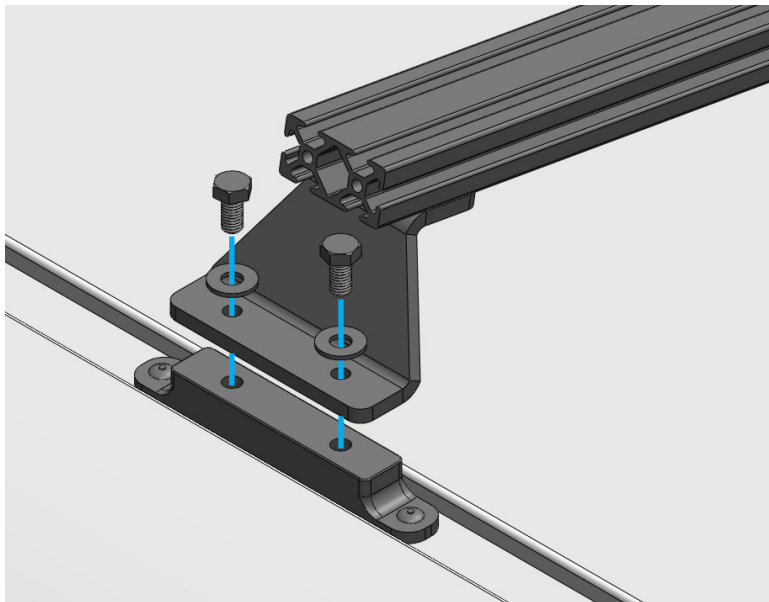

WE RECOMMEND PLACING THE FULL RACK BACK ON THE ROOF FOR THE REMAINING STEPS. IMAGES ARE SHOWN WITHOUT SIDES FOR ILLUSTRATIVE PURPOSES.

MOUNTS

Required Components:
12x M8 Bolts
12x M8 Flat Washers

Next, re-install the assembled rack on the roof, allowing the mounting brackets to rest on the rivet feet. If these do not line up, loosen the hardware that secures the mounting bracket to the cross member and adjust as needed. Fasten the mounting bracket to the rivet spacer using the M8 x 16 hex bolt and washers with the addition of a drop of blue threadlocker on the bolt threads supplied with the rack.

Once satisfied with how the rack sits on the vehicle, tighten down all hardware between the cross members and the mounting brackets. The rack should not need adjusting after this step.

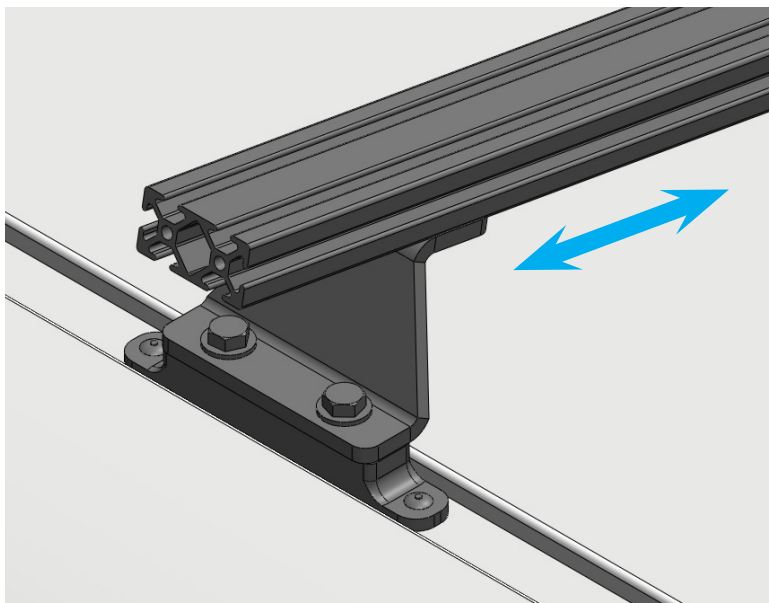

TORQUE SPEC: 22in-lb

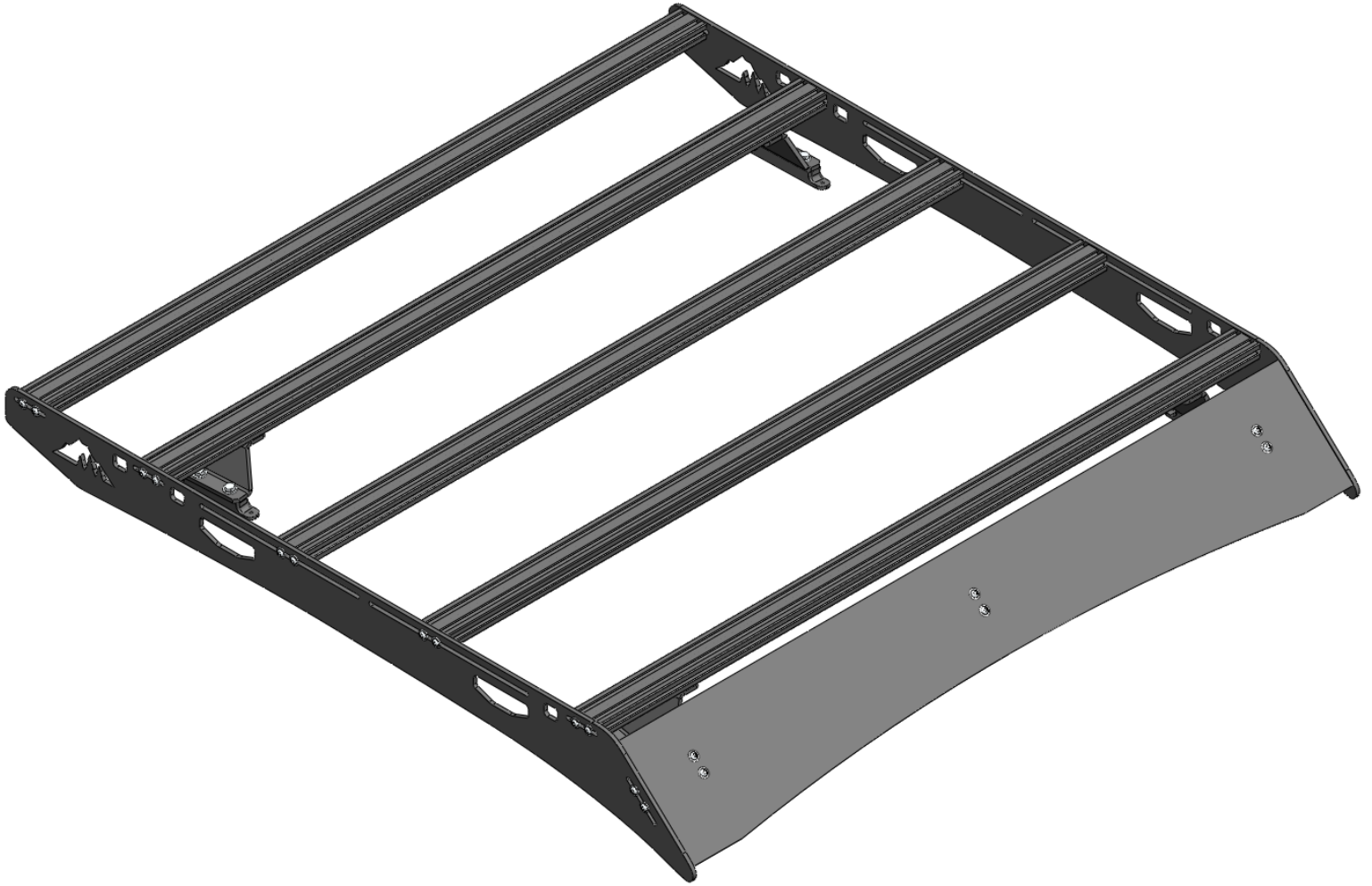

CROSS MEMBERS

Required Components:

12x 1/4"-20 x 1" Socket buttons

12x 1/4" Flat washers

3x 47" Cross members

Secure all of the remaining cross members to the rack system using the 1" socket buttons and washers in the open slots in the sideplate. Position according to your load requirements.

EXPLORE.

A white SUV is driving away from the viewer on a dirt road at night. The vehicle's headlights are on, illuminating a large cloud of dust or dirt kicked up by the tires. The background is dark, showing silhouettes of hills or mountains under a dark sky.

All products built and designed by Sherpa Equipment Company are intended for off-road use and should be assembled, installed, and used according to Sherpa Equipment Company's recommendations. Sherpa Equipment Companies products should be used safely with good judgment towards others and surroundings.

By installing Sherpa Equipment Companies products on your vehicle you assume all liability. Sherpa Equipment Company will not be held liable for damages or loss associated with the installation or use of its products. It is recommended that you inspect your roof rack within the first 100 miles of installation and every 500 miles after.