



THE RAMMSTEIN

I N S T A L L I N S T R U C T I O N S

HARDWARE CHECKLIST

Exact hardware color counts may vary based on the options selected at checkout.

4
1/4"-20
(1")



32
1/4"-20
(1")



8
M8 Hex Bolt
(16mm)



12
1/4"-20
(9/16")



6
1/4"-20
(1/2")



18
1/4" Tnut



4
1/4" Nylock
Nut



58
1/4" Flat
Washer



8
M8 Flat
Washer

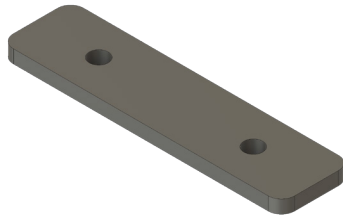

4
TRACK ANCHOR
PLATE

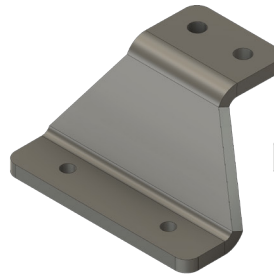

2
REAR (R)
MOUNTING
BRACKETS

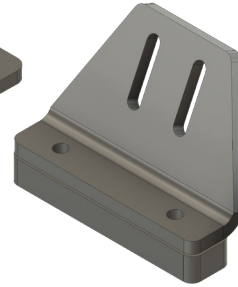

2
FRONT
ADJUSTABLE
MOUNTS

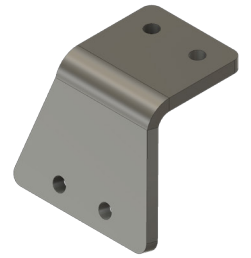

2
Middle (M)
MOUNTING
BRACKETS

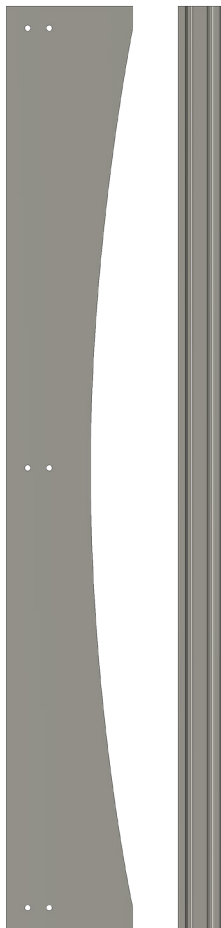

USING TNUTS

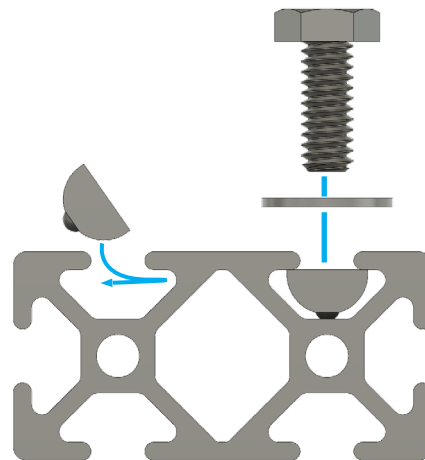

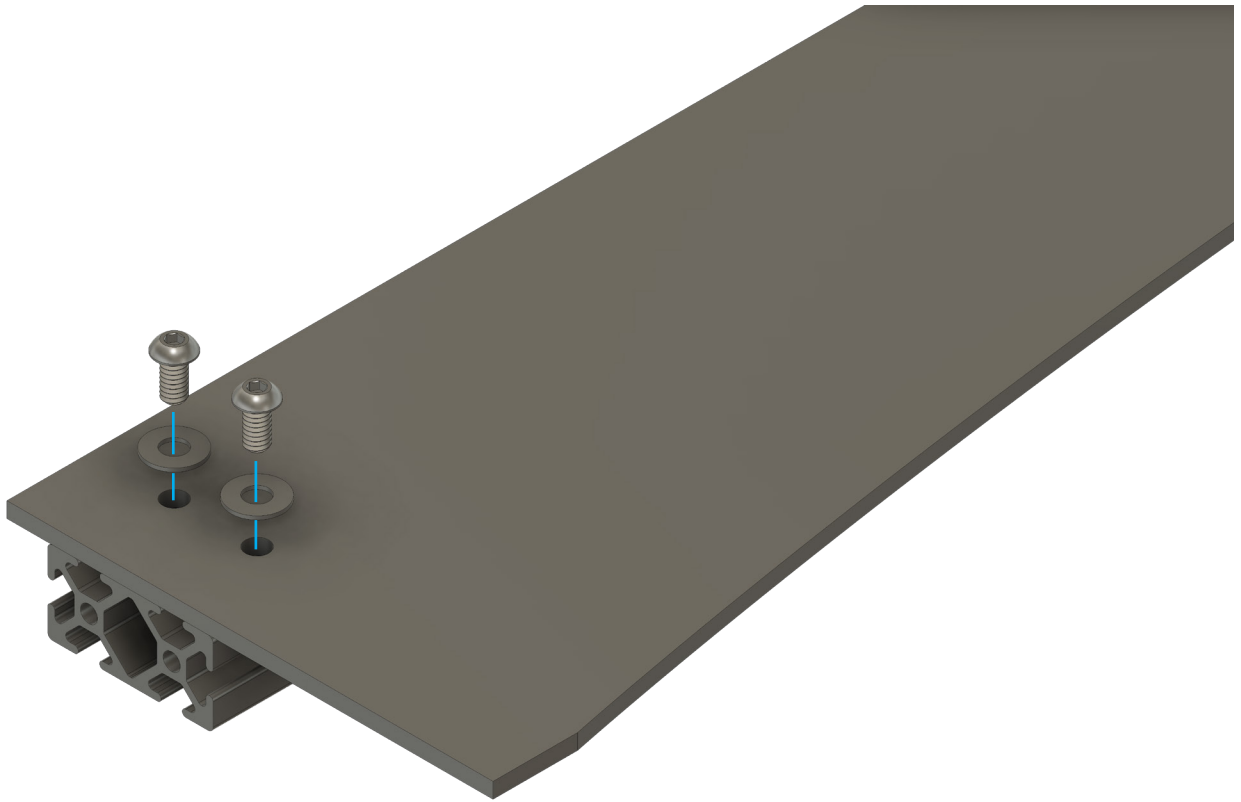

PRE-ASSEMBLY

Required Components:

6x 1/4"-20 x 1/2"

6x 1/4" Flat Washers

6x Tnuts

Drop 6 tnuts into the slots on the cross member and line them up with the holes in the fairing. Secure with 6 bolts and washers.

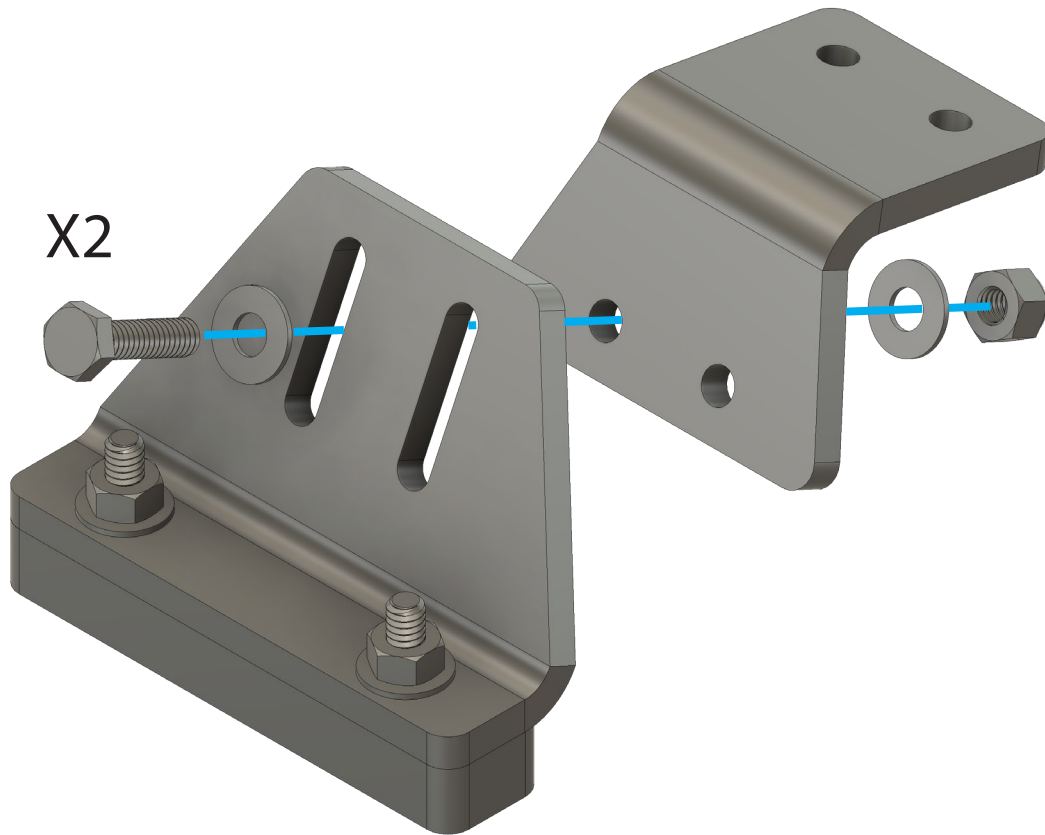

PRE-ASSEMBLY

Required Components:

- 4x 1/4"-20 x 1"
- 12x 1/4" Flat Washers
- 4x Nylon Lock Nuts
- 4x 1/4" Nut

Leave the hardware in the center of the leveling mount loose so that it can be adjusted during a later step.

FOR MOST RACK SYSTEMS THE RUBBER PAD WILL COME PRE-ASSEMBLED.

01

Required Components:

4x 1/4"-20 x 5/8"

4x 1/4" Flat Washers

4x Tnuts

Start by positioning the cross member vertically. Next, drop the 4 tnuts into the slotted profile of the extrusion, then fasten the front leveling mounts to the crossbar by threading 4 bolts and washers through the leveling bracket and into the tnut.

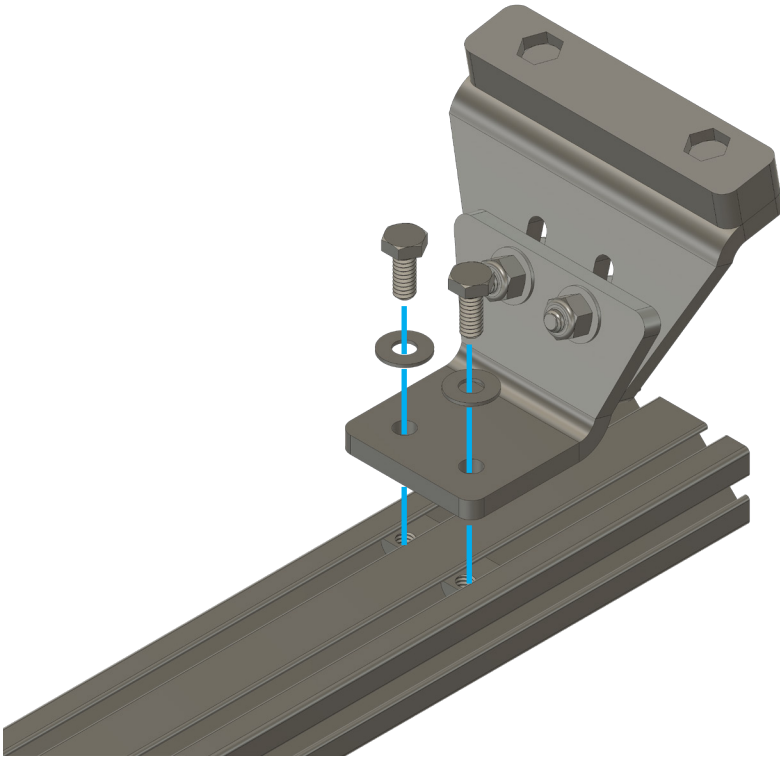

02

Required Components:

8x 1/4"-20 x 5/8"

8x 1/4" Flat Washers

8x Tnuts

Drop the 8 tnuts into the slots of two crossbars, two in each track. Bolt the top of the mounting brackets to the cross member, one foot on each end as shown in the diagram. There is a rear pair and middle pair of brackets, denoted by the letters etched in the middle face. The notch in the bottom corner of the bracket faces towards the front of the vehicle. Leave this hardware loose so that it can be adjusted once the cross members are placed on the vehicle.

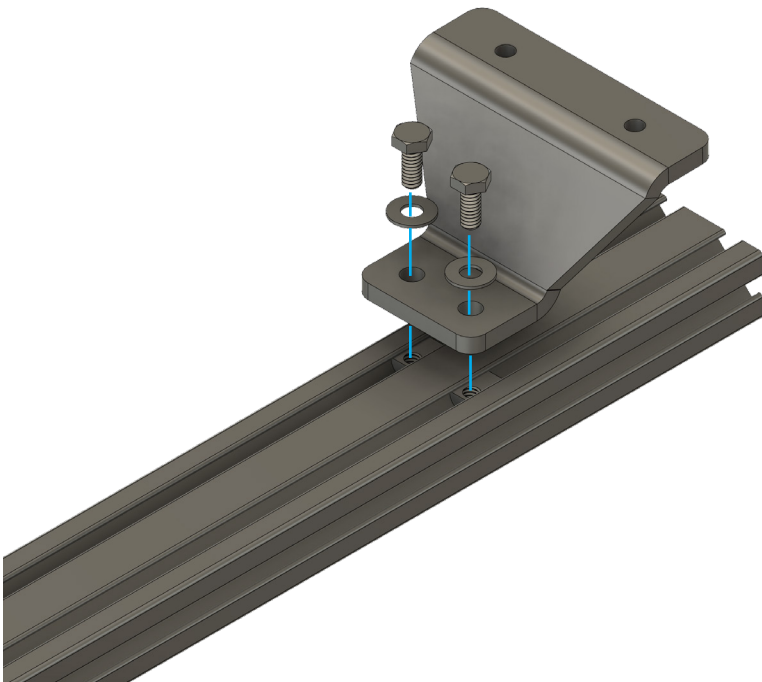

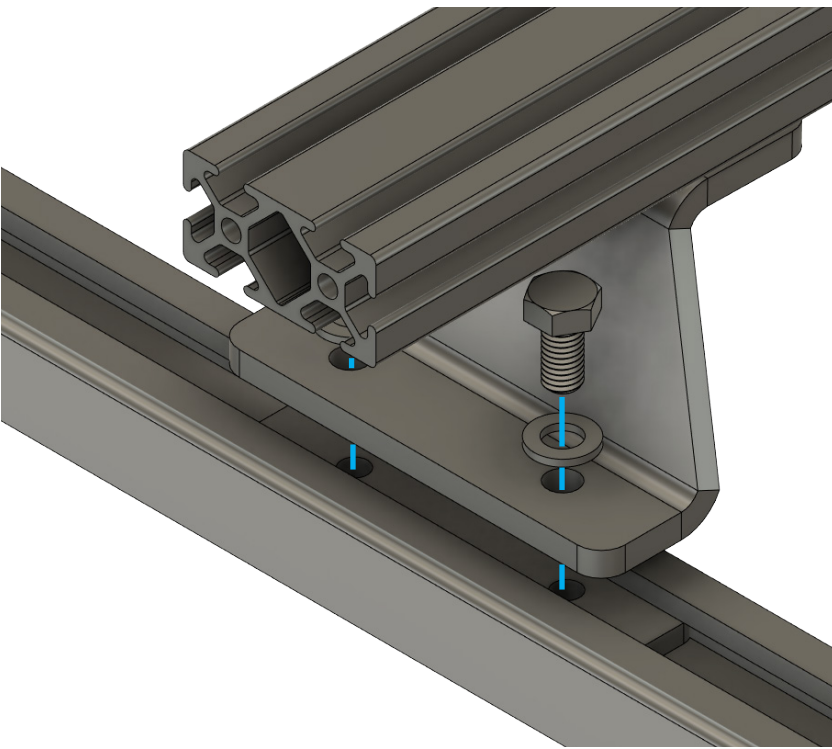

03

Required Components:

- 8x** M8 Bolts
- 8x** M8 Flat Washers
- 4x** M8 Anchor Plates

With the two main support cross members assembled, flip them over and align the mounting brackets with the OEM roof tracks. Secure them to the vehicle using eight M8 bolts and washers, passed through the mounting bracket and into the anchor plates in the roof track. Leave this hardware loose so that it can be adjusted once the side plates are attached.

Center the cross members on the vehicle using a tape measure and tighten them to the mounting bracket.

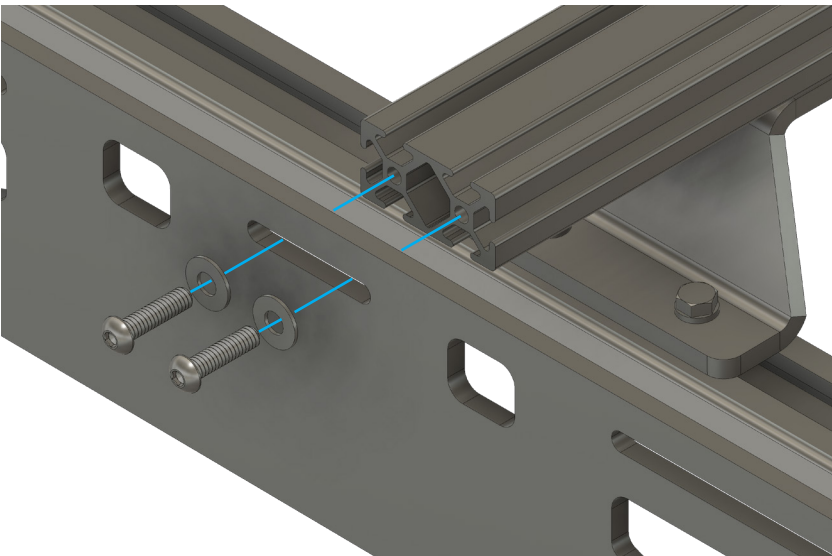

04

Required Components:

- 8x** 1/4"-20 x 1"
- 8x** 1/4" Flat Washers

After the main support cross members have been secured to the vehicle, you can install the side plates. Align the slots in the rack side with the ends of the main support crossmembers. Secure it using 8 bolts and washers. Leave the bolts loose enough to move the sideplate to the position that matches the curve of the vehicle.

Once the rack is positioned correctly, tighten down all of the hardware for the rack sides, mounting hardware and roof track bolts.



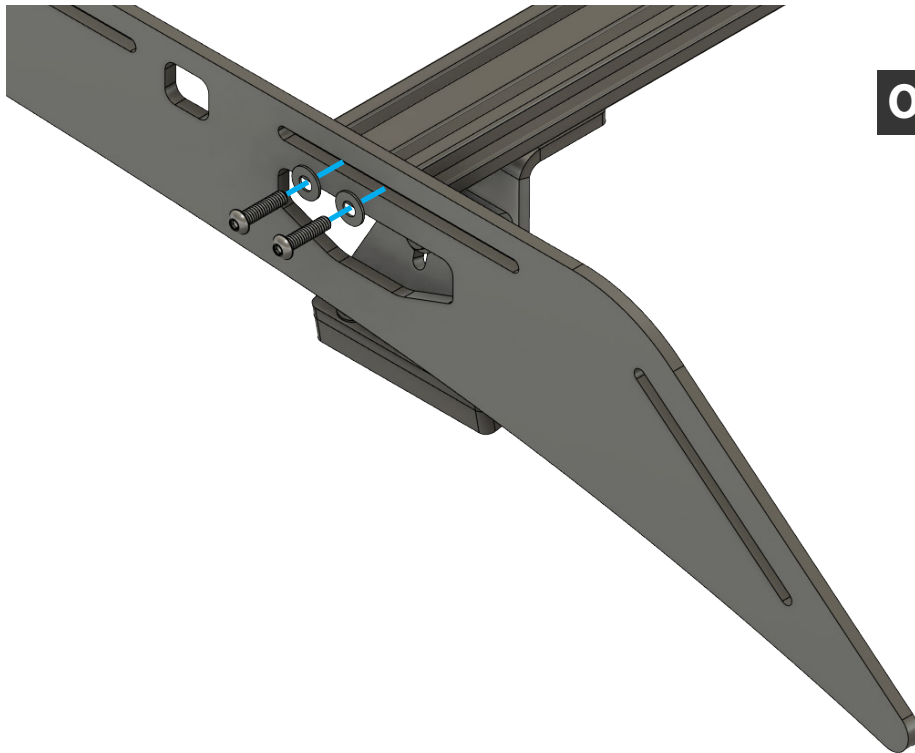

05

Required Components:

4x 1/4"-20 x 1"

4x 1/4" Flat Washers

With the side plates attached to the vehicle, align the vertical cross member (with adjustable leveling mounts) to the front vertical slot. Set the height and angle of the adjustable mount so that the rack lines up well with the curvature of the roof, and the foot is tight against the roof surface. Sliding it back along the slot can allow for a tighter fit if necessary. More on this process in install step-08. Fasten the two front mounts with 4x socket buttons and washers.

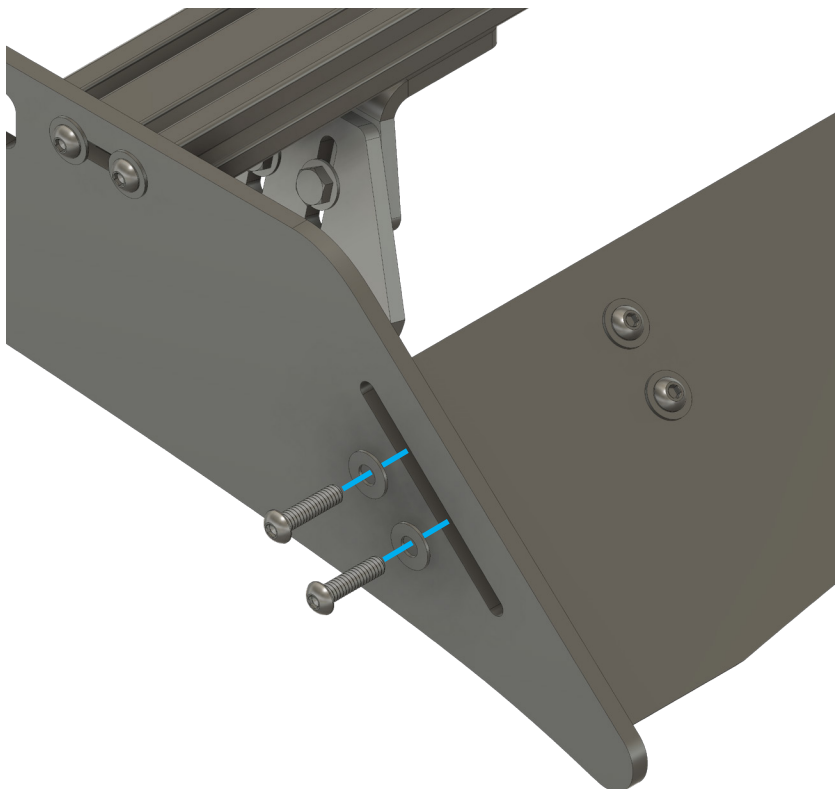

06

Required Components:

4x 1/4"-20 x 1"

4x 1/4" Flat Washers

Position the wind fairing in line with the diagonal slot at the front of the rack. Align the bottom of the fairing with the tip of the roof rack and secure it using 4 bolts and washers.



07

Required Components:

16x 1/4"-20 x 1"

16x 1/4" Flat Washers

Secure all of the remaining cross members to the rack system. Position according to your load requirements.

08

Once the rack has been fully assembled on the vehicle it is time to setup the front adjustable leveling mounts. We recommend an extra set of hands for this step. You may also need to loosen the middle mounts for this step depending on your configuration.

Pull up firmly on the front of the rack, and insert a microfiber towel or wedge. Then push the bottom of the mounting foot down, and then tighten the hardware in the center of the mount. We recommend positioning these mounts on the rubber gutter trim to prevent possible paint damage.

Once the mounts are in the correct position remove the "wedge" and inspect the rack to make sure it is firm.

EXPLORE.

All products built and designed by Sherpa Equipment Company are intended for off-road use and should be assembled, installed, and used according to Sherpa Equipment Company's recommendations. Sherpa Equipment Companies products should be used safely with good judgment towards others and surroundings.

By installing Sherpa Equipment Companies products on your vehicle you assume all liability. Sherpa Equipment Company will not be held liable for damages or loss associated with the installation or use of its products. It is recommended that you inspect your roof rack within the first 100 miles of installation and every 500 miles after.