



SHERPA
PREMIUM RACK SYSTEMS

THE RAINIER

RACK SYSTEM INSTALL GUIDE

HARDWARE CHECKLIST

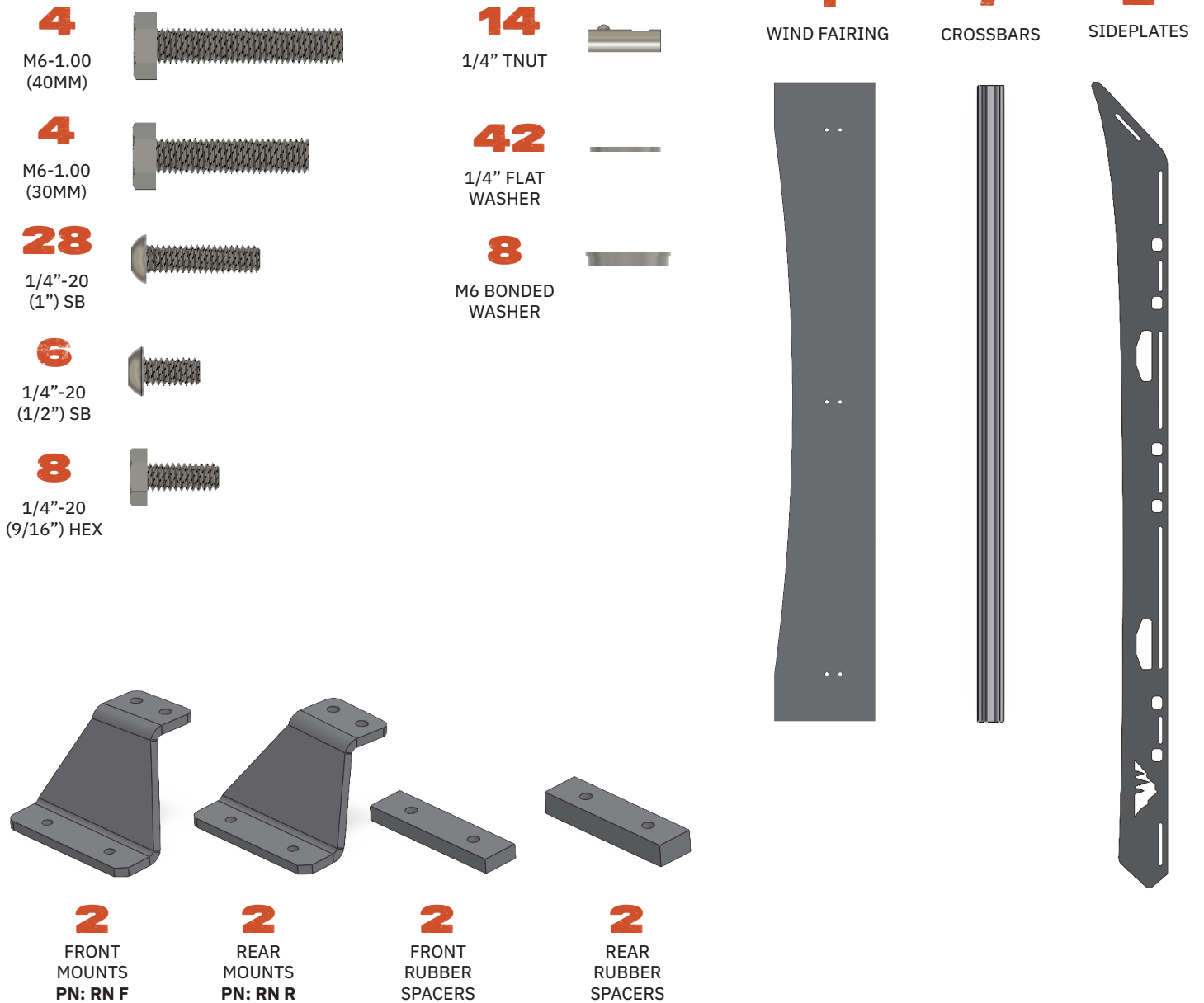

BEFORE YOU START

Remove your stock roof rack (if applicable). Loosen all stock rack bolts before fully removing any of them. This will prevent the capture plates from working loose inside of the roof. Work slowly when removing the stock rack as not to break the plastic sleeves.

The below assembly images may differ slightly in appearance from actual product.

USING TNUTS

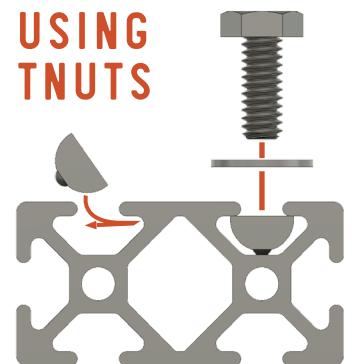

PRE-ASSEMBLY

01 WIND FAIRING

Required Components:

- 1 Crossbar
- 6 1/4"-20 x 1/2"
- 6 1/4" Flat Washers
- 6 Tnuts

Drop 6 tnuts into the slots on the crossbar and line them up with the holes in the fairing. Secure with 6 bolts and washers.

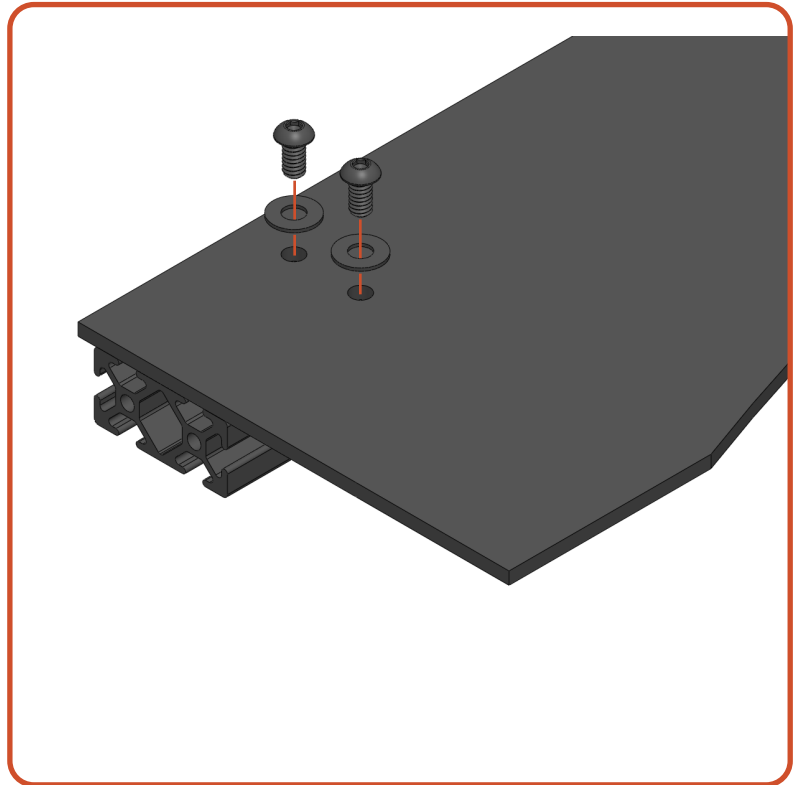

02 FRONT MOUNT

Required Components:

- 1 Crossbar
- 2 Front Mounts **PN: RN R**
- 4 1/4"-20 x 9/16"
- 4 1/4" Flat Washers
- 4 Tnuts

Drop 4 tnuts into the slots on the crossbar and line them up with the holes in mounts. Secure top of the mounting bracket to the crossbar leaving the hardware loose so that it can be adjusted during a later step.

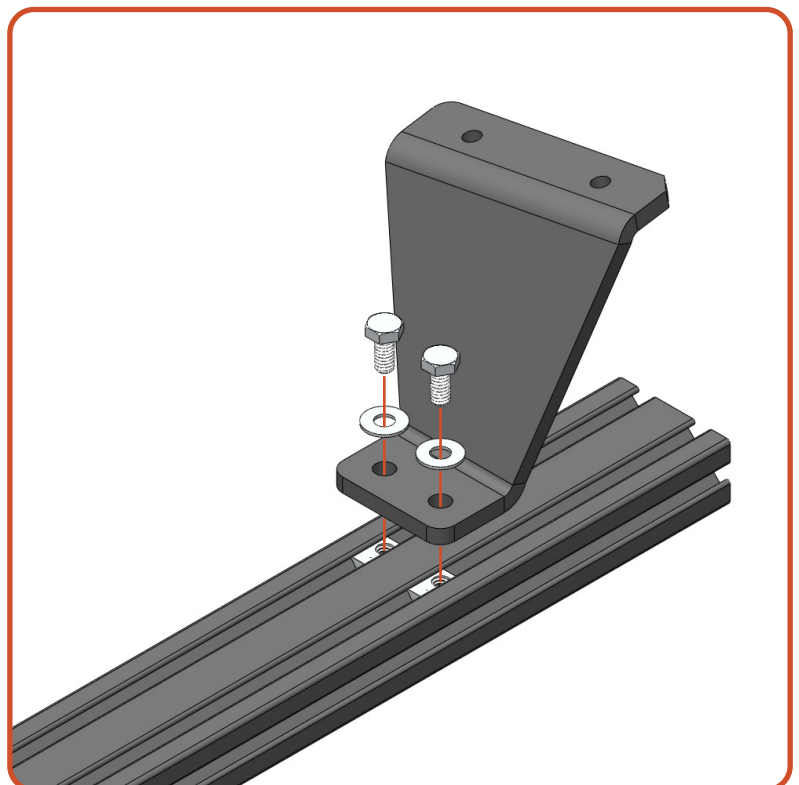

03 REAR MOUNT

Required Components:

- 1 Crossbar
- 2 Rear Mount **PN: RN R**
- 4 1/4"-20 x 9/16"
- 4 1/4" Flat Washers
- 4 Tnuts

Drop 4 tnuts into the slots on the crossbar and line them up with the holes in mounts. Secure top of the mounting bracket to the crossbar leaving the hardware loose so that it can be adjusted during a later step.

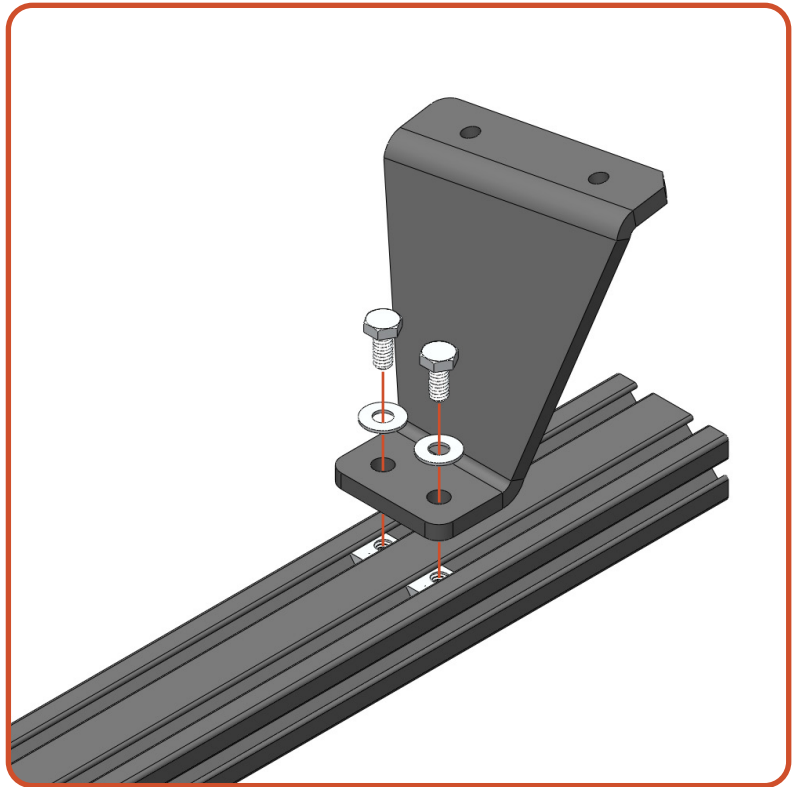

FINAL ASSEMBLY

01 FRONT & REAR MOUNTS

Required Components:

- 4 M6-1.00x30
- 4 M6-1.00x40
- 8 M6 Bonded Washers
- 2 Front Rubber Spacers
- 2 Rear Rubber Spacers

Position the mounting bracket over the rubber spacer and secure it with bolts and bonded washers passed through the bracket, rubber, and into the holes in the roof.

Note: The thicker rubber spacers and 40mm bolts go on the rear mounts.

Note: Chamfered corner on the lower part of the mount faces the front of the vehicle.

The bonded washers should compress and become flat, but not concave. Do not over tighten these mounts.

TARGET TORQUE SPEC: 22in-lb

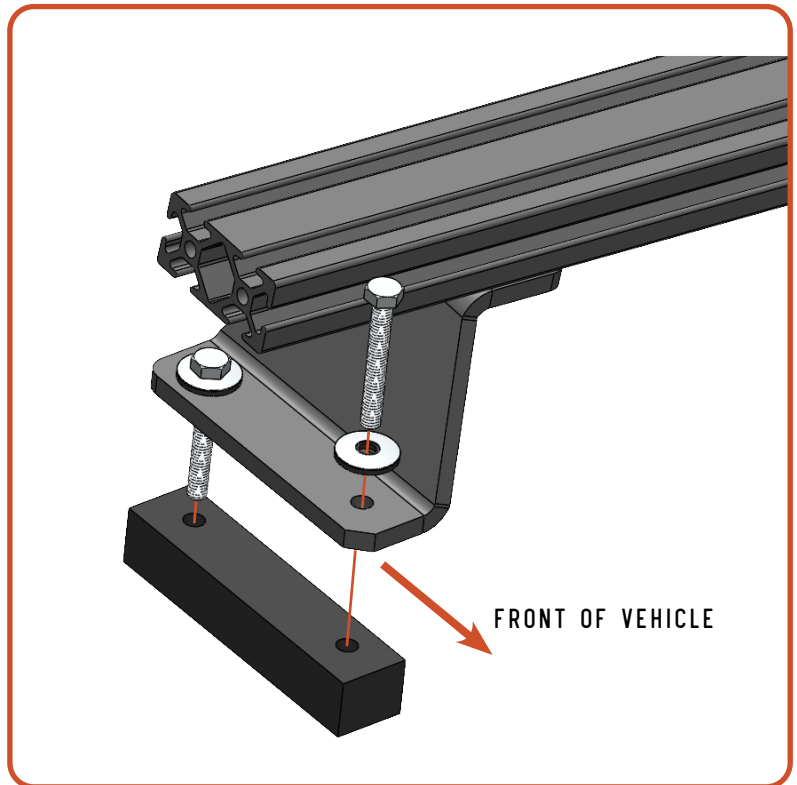

02 SIDEPLATES

Required Components:

- 2 Sideplates
- 8 1/4"-20 x 1" SB
- 8 1/4" Flat Washers

After the main support crossbar have been secured to the vehicle, use a tape measure and center all of the bars on the vehicle. Measure from the inside edge of the mount to the outside face of the crossbar and make these equal side-to-side.

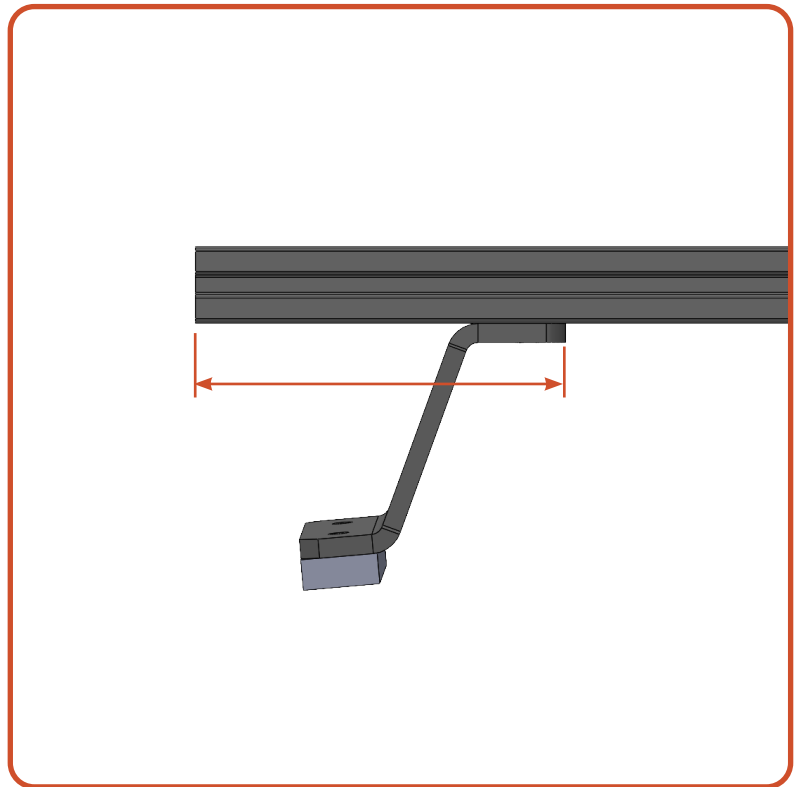

Next, align the small slots in the sideplates with the ends of the main support crossbars. Secure them using bolts and washers. Leave the bolts loose enough to move the sideplate to the position that matches the curvature of the vehicle.

Once the rack is positioned correctly, tighten down all of the hardware for the sideplates.



03 WIND FAIRING

Required Components:

4 1/4"-20 x 1" SB

4 1/4" Flat Washers

Position the wind fairing in line with the diagonal slot at the front of the rack. Align the bottom of the fairing with the tip of the roof rack and secure it using bolts and washers.

The fairing can be adjusted up or down if wind noise is detected.

Small adjustments make a big difference here.

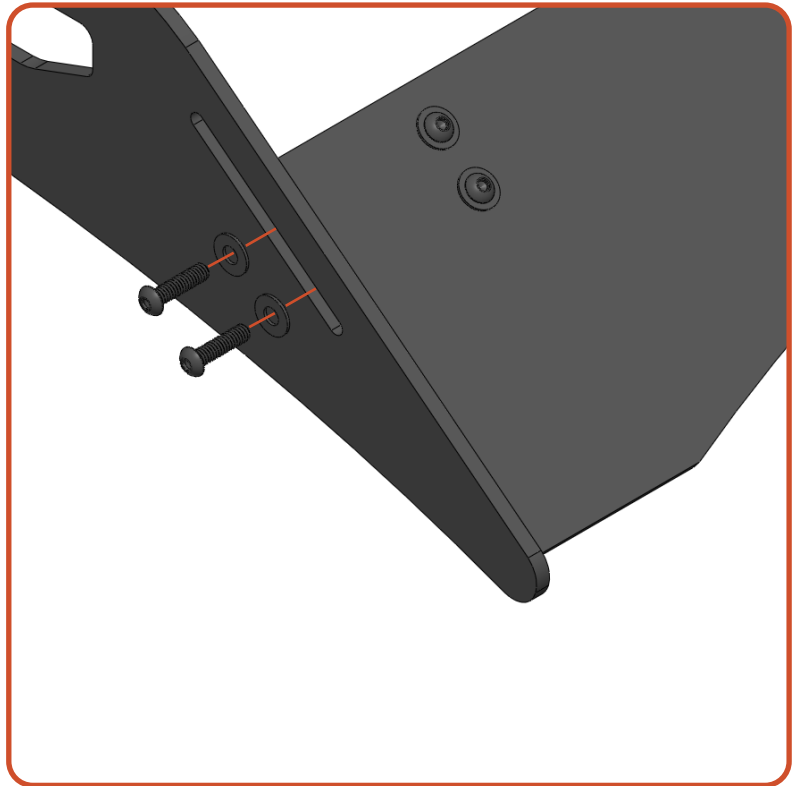



04 FREE CROSSBARS

Required Components:

4 Crossbars

16 1/4"-20 x 1" SB

16 1/4" Flat Washers

Secure all of the remaining crossbars to the rack system. Position according to your load requirements.

NOW GET OUT THERE AND
EXPLORE.

WELCOME TO THE SHERPA FAMILY!
MAKE SURE TO FOLLOW US ON YOUR SOCIALS AND TAG US IN YOUR ADVENTURES.

All products built and designed by Sherpa Equipment Company are intended for off-road use and should be assembled, installed, and used according to Sherpa Equipment Company's recommendations. Sherpa Equipment Company's products should be used safely with good judgment towards others and surroundings.

By installing Sherpa Equipment Company's products on your vehicle you assume all liability. Sherpa Equipment Company will not be held liable for damages or loss associated with the installation or use of its products. It is recommended that you inspect your roof rack within the first 100 miles of installation and every 500 miles after.