



WARNING: When using Sloggn Base Deck and accessories, the user must understand the precautions. The points listed below will assist you in using the rack system and will encourage safety.

- For quality fits and safety, use only the recommended Sloggn Gear rack or accessories.
- The maximum load specified in the assembly instructions is not to be exceeded. However, this limit is always subordinate to the maximum load recommended by the manufacturer of the car itself. It is always the lower maximum recommended load that applies. Max load = load carrier weight + any fitted carrier accessories + the weight of the load itself.
- Make sure all knobs, bolts, screws, straps, and locks are firmly attached, tightened, and locked before every trip. Knobs, bolts, screws, straps, and locks must be periodically inspected for signs of wear, corrosion, and fatigue. Check your gear at stops during the trip to ensure continued fastening security.
- Check local and state laws governing the projection of objects beyond the perimeter of a vehicle. Be aware of the width, length, and height of your cargo since low clearance branches, bridges, and parking garages can affect the load. All cargo will affect the vehicle's driving behavior. Never drive with any lock, knob, or rack in an open or unlocked position.

- Remove your Sloggn rack and accessories when they are not in use and before entering automatic car washes.
- For the safety of your vehicle and rack system, obey all posted speed limits and traffic cautions. Adapt your speed to the conditions of the road and the load being carried.
- Do not use Sloggn Gear and accessories for purposes other than those for which they were designed. Do not exceed their carrying capacity. Failure to follow these guidelines or the product's instructions will void the warranty.
- All loads must be secured using the provided hardware.
- Use of the carrier is restricted to Class II (and higher), 2" or 1 1/4" receiver hitch.
- Do not allow people to climb, get into, or sit on the carrier at any time.
- Do not use this carrier for transporting people, animals, or flammables.
- Not for off-road use.
- Vehicle taillights must remain visible.
- Contact customer service if you have any questions regarding the operations and limits of Sloggn products. Review all instructions and warranty information carefully.

Parts List:

Images not to scale

1.25 - 2 inch
Filler Block

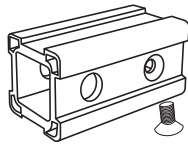

(6) 8mm Carriage Bolt,
Lock Nut & Washer



12mm Wobble Bolt

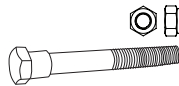

8 + 12mm Deck Wrench



5mm Allen Wrench



1.25" Tow Bar

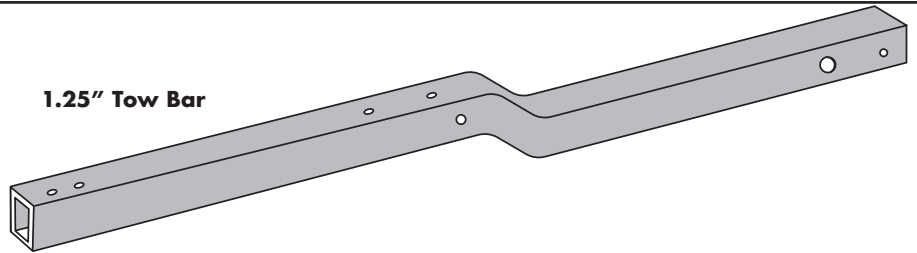

Deck Plate

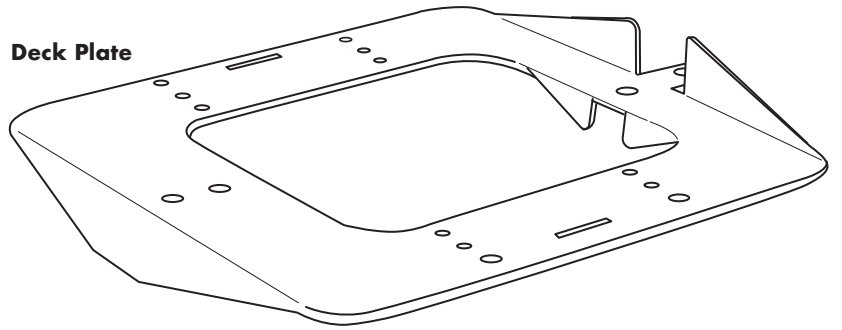

1 Hitch Receiver Size:

First determine your hitch size, the Sloggn Base Deck fits both 1.25" and 2" standard size hitches. The 1.25" hitch is, wait for it, 1.25" wide (about the width of a fat thumb) and the 2" is 2" wide, about the width of the narrow side of a credit card.

If you have a 1.25" hitch, remove the two 5mm hex screws from the Filler Block

2"

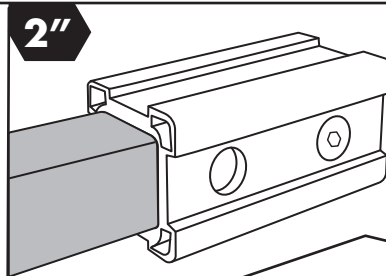

1.25"

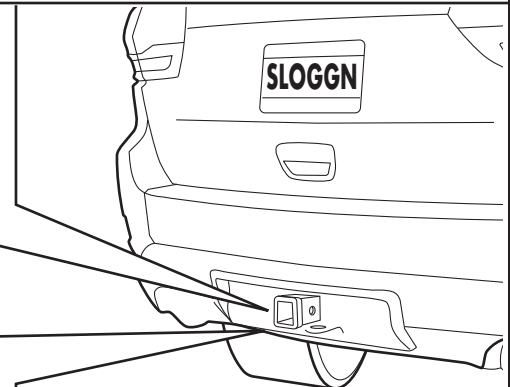
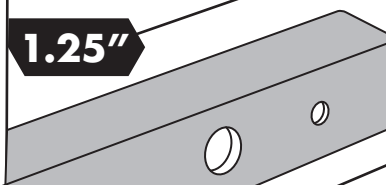

2 Attach Tow Bar to Hitch Receiver

- With Tow bar in high position, insert bar into hitch receiver.
- Insert No-wobble bolt into receiver hole.
- Tighten bolt using 12mm Deck Wrench or your own wrench. There should not be any movement on the bar inside of the hitch when done.
- For added security, add lock nut on other side of No-wobble bolt

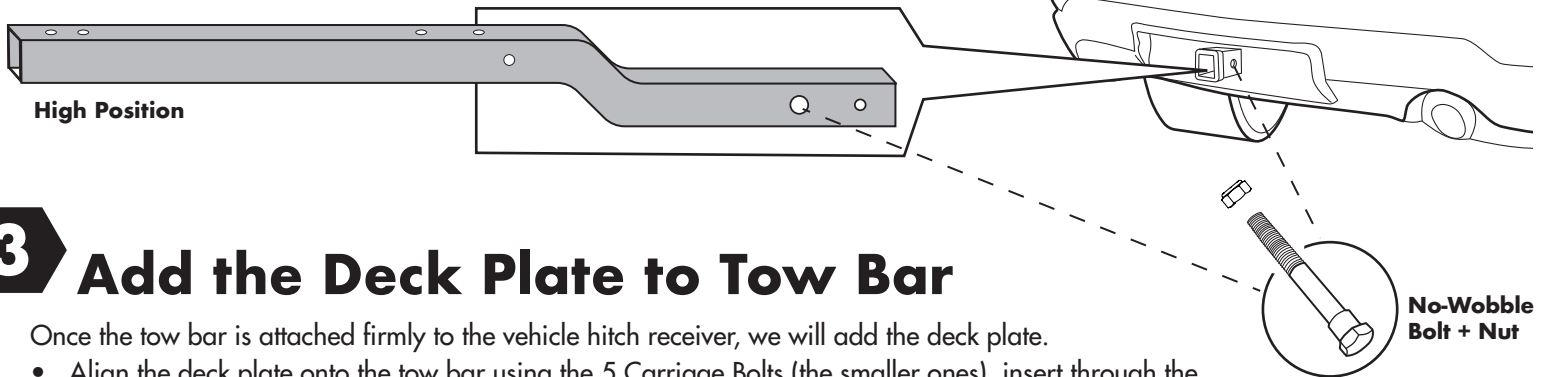

3 Add the Deck Plate to Tow Bar

Once the tow bar is attached firmly to the vehicle hitch receiver, we will add the deck plate.

- Align the deck plate onto the tow bar using the 5 Carriage Bolts (the smaller ones), insert through the holes marked below.
- Use the included Deck Wrench to tighten the 8mm Lock Nuts with washer, you should tighten so it is firmly attached (to the extent that you may have a slight indentation on your hand, but not so hard that it hurts).

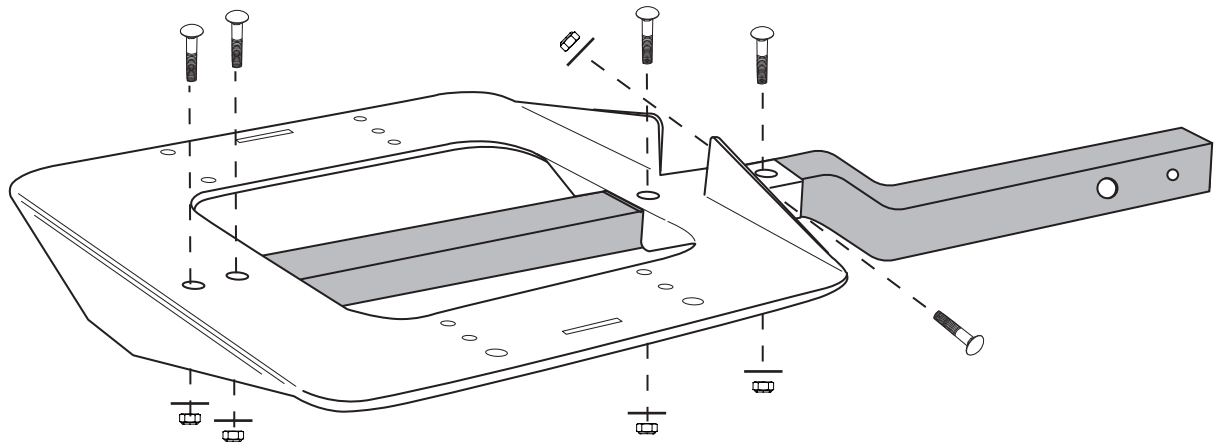

4 Attach Accessory

Follow the instructions that were included with your Sloggn Awesome Accessory for specific instructions on attaching your accessory.

Note: The Tow Bar can be flipped to the low position, to create more space for your tailgate to open. This will depend on your vehicle and accessory type.



NEED HELP? Contact us.
Do not return this product to your retailer, email us!

100% KARE Warranty (Kick Ass Remedy Experience)

We do our best to create the finest gear in the market, however on occasion we don't nail it the first time. For this reason, Sloggn unconditionally guarantees its products against defects in materials, design and craftsmanship for the practical lifetime of the product. If the product just got too much love (you can never get too much love but...) or you abused it in a fit of rage we have a great upgrade, repair and replace programs at a very reasonable rate.

SLÖGGN
GEAR

Sloggn Gear LLC] [Burlington, VT USA
(802) 575-6446] [info@sloggn.com

www.SLOGGN.com