



Product presentation:
TWIN BELL

TWIN BELL



Features



1. Doors can be lifted to create shade
2. Zippable panel to add transparent panel, technical panel, heat panel... (x4)
3. Opening for insulation layer
4. Zippable panel to add transparent panel, technical panel, heat panel... (x4)



Features (section view)

1. Insulating double roof design
2. Large doors to enter without bending (x4)
3. Large sidewindows (x4)
4. Interior curtain to control light & draft from the inside



Dimensions



Tent info	
Exterior height	325 cm
Interior height (with double roof)	293 cm
Door center height	230 cm
Door side height	170 cm
Door width	300 cm
Exterior wall height	86 cm
Interior wall height (with double roof)	71 cm
Width	550 cm
Length	726 cm
Groundsurface	32,6m ²
Tub height	13 cm
Weight of tent	90 kg
Number of small windows	4
Number of large windows	4
Number of roof vent	4
Cable inlet	Optional

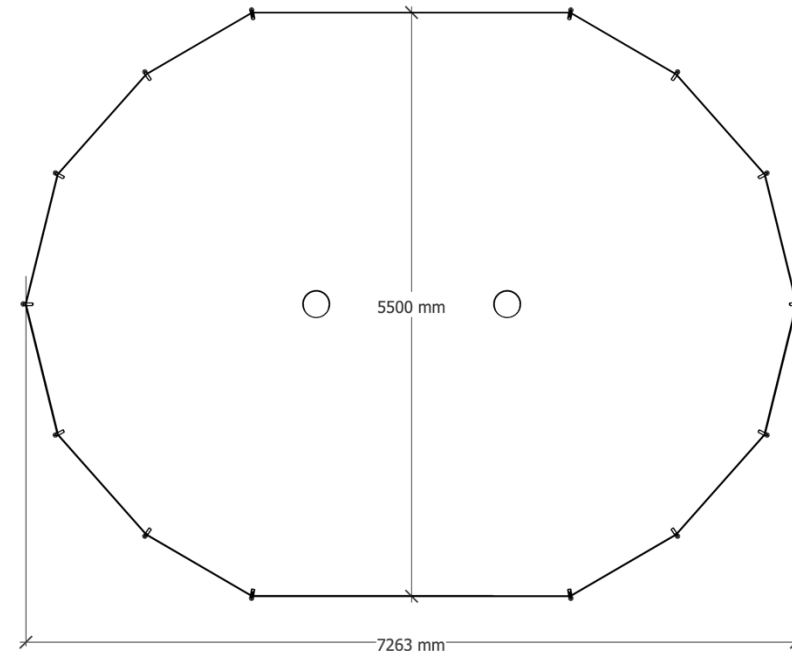
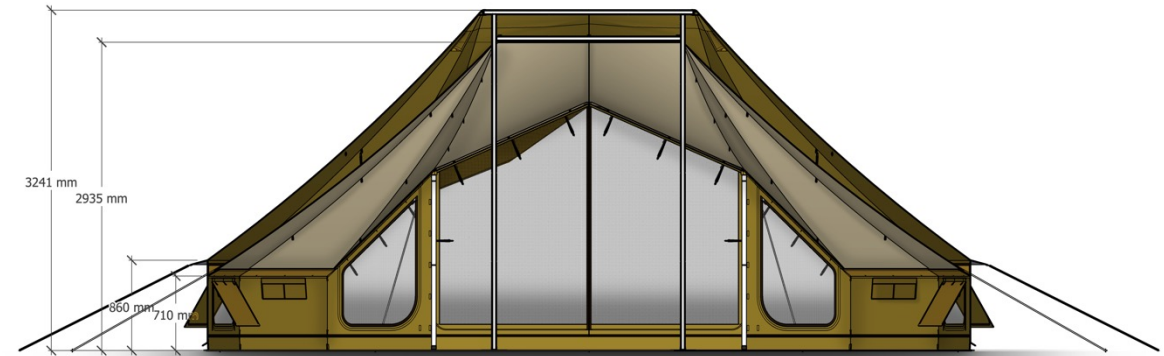

Used materials



Tent info	
Groundsheet material	Grey PVC leather look – green bottom 550 GSM
Canvas	Cotton 320 GSM Aubergine/ Blue lagoon/ Desert/ Roasted pumpkin/ Turmeric/ Treatment: Rot-mildew resistance, Colour fastness, Water resistance
Double roof	Trevira fabric
Divider	Trevira fabric
Mosquito	Polyester olive colour/ silver colour
Center pole	∅40x2; Aluminium champagne colour
A-frame	∅40x2; Aluminium champagne colour

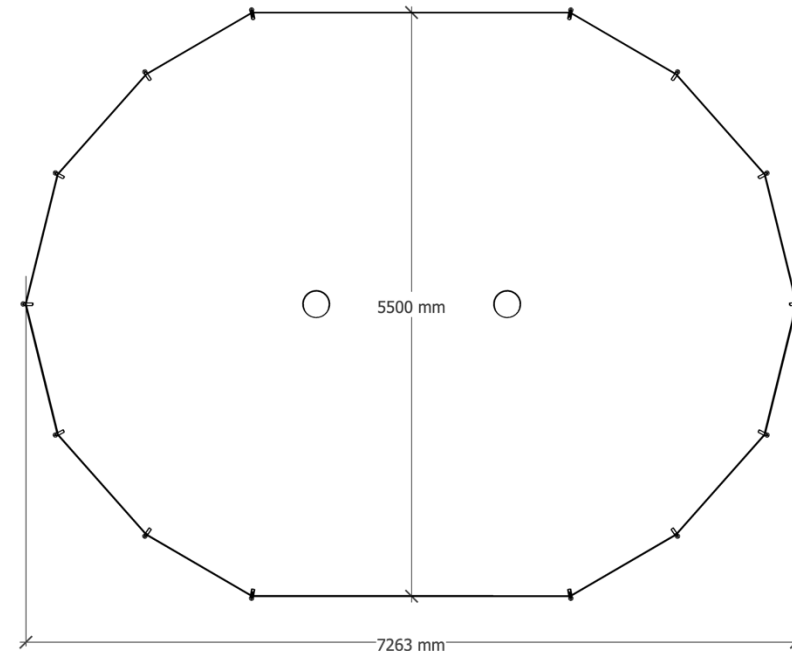
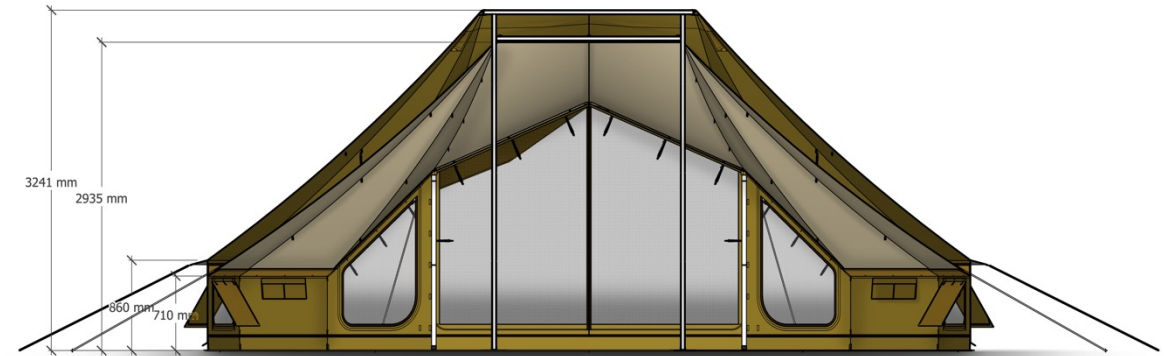

Divider option: Family suite

Divider to split the tent into 4 equal compartments.

Example of arrangement options:

- 4 single beds,
- 4 double beds,
- 2 double beds + 2 seating areas
- 3 single beds + 1 common seating area
- ...

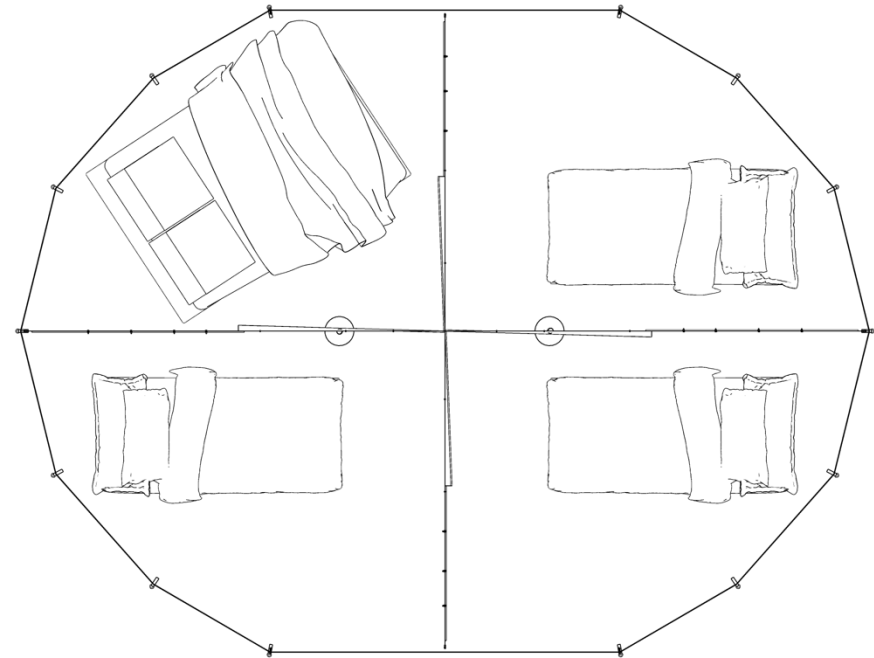
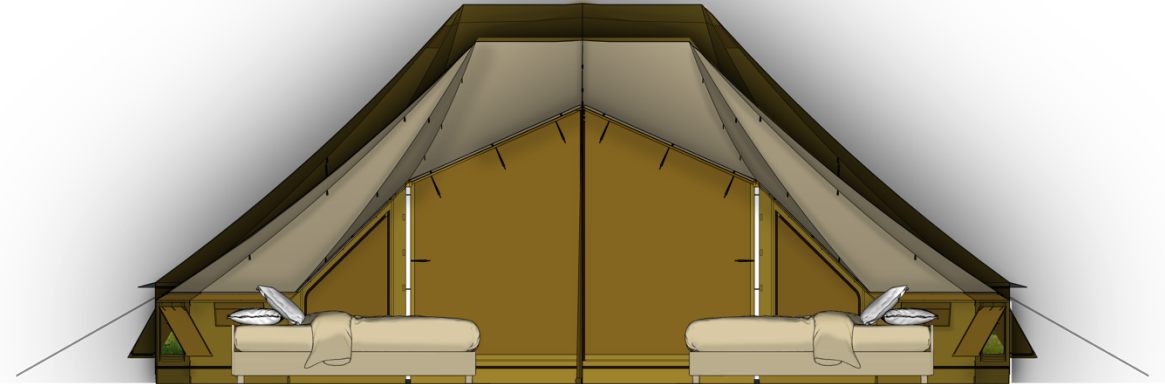

Divider option: Single suite

Divider to split the tent into 2 compartments.

Example of arrangement options:

- 1 double beds + large seating & lounging area
- 4 single beds + 1 double bed
- ...

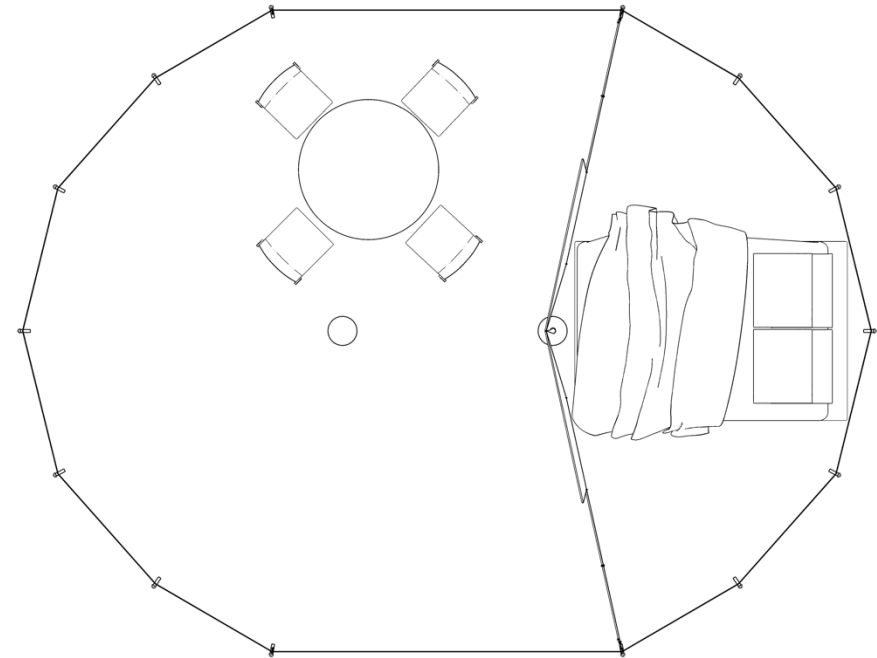

Divider option: Double suite

Divider to split the tent into 3 compartments.

Example of arrangement options:

- 2 double beds + common seating & lounging area
- ...

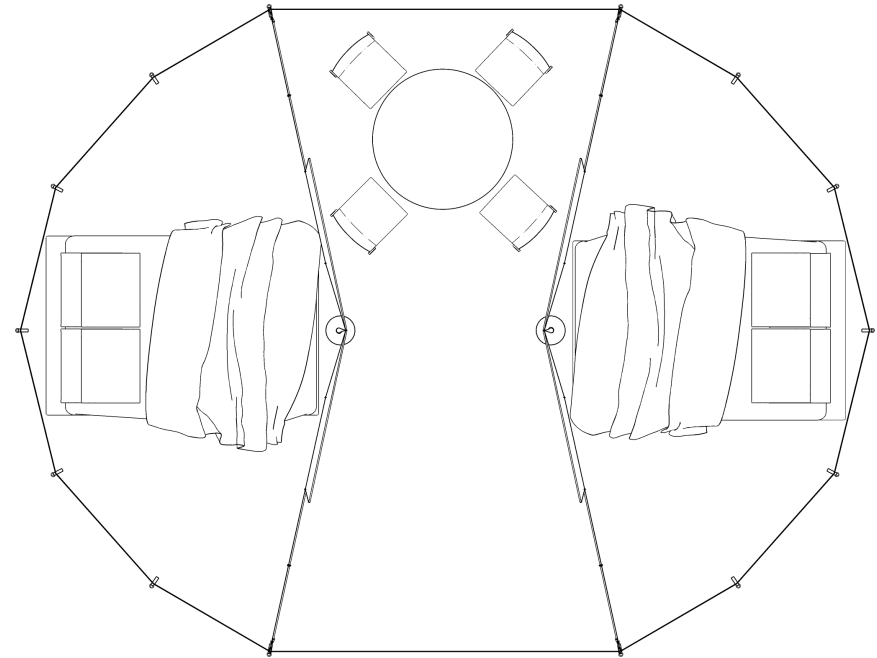
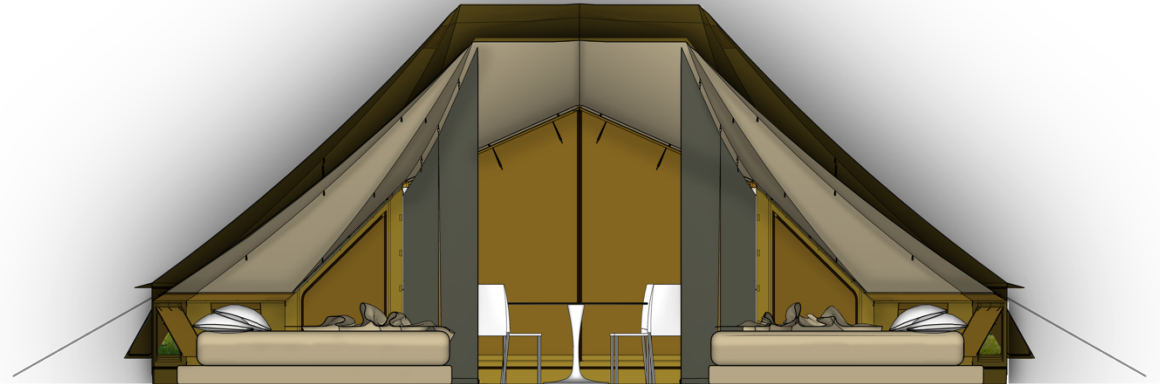

Front View

ORGANIC-CONCEPT



Back View

