



*The Premium Collection*

Ambient and Refrigerated models

# SERVICE and PARTS MANUAL



700 Seaga Drive, Freeport, IL 61032, U.S.A. visit: [seagamfg.com](http://seagamfg.com) email: [info@seagamfg.com](mailto:info@seagamfg.com)

## INTRODUCTION

Congratulations on the purchase of your vending machine. This vending machine has been designed to give you many years of dependable service. It requires little maintenance and is easy to set up and operate.

## READ THIS MANUAL COMPLETELY

Your vending machine is designed to operate simply and reliably, but to take full advantage of your vendor, please read this owner's manual thoroughly. It contains important information regarding installation and operations, as well as a brief trouble-shooting guide.

## EQUIPMENT INSPECTION

After you have received your vendor and have it out of the box, place it on a secure surface for further inspection. **Note:** Any damages that may have occurred during shipping must be reported to the delivery carrier immediately. Reporting damages and the seeking of restitution is the responsibility of the equipment owner. The factory is willing to assist you in this process in any way possible. Feel free to contact our Customer Care Department with questions you may have on this process.

It is important that you keep the original packaging for your vending machine at least through the warranty period. If your machine needs to be returned for repair, you may have to purchase this packaging if it is not retained.

Once you have your vendor located, we suggest that you keep this manual for future reference, or you can view this manual online at [www.seagamfg.com](http://www.seagamfg.com). Should any problems occur, refer to the section entitled "COMMON QUESTIONS AND ANSWERS". It is designed to help you quickly identify a problem and correct it.

## MANUFACTURER'S WARRANTY

### **WHAT IS COVERED:**

Manufacturer warrants TO THE ORIGINAL PURCHASER ONLY that each item of equipment manufactured is free from defects in material and workmanship under normal use and service. Manufacturer's obligation under warranty shall be limited to repair or replacement, at our plant, of any parts of the equipment, which shall, within one year of the date of shipment to the original purchase, be demonstrated to be defective. The original purchaser may obtain repair or replacement of the equipment under warranty by returning the defective item or entire vendor to the Manufacturer, freight prepaid.

### **WHAT IS NOT COVERED:**

Manufacturer's warranty obligations DO NOT EXTEND TO OR INCLUDE installation expenses, vandalism, or difficulties resulting from failure to operate equipment in accordance with Manufacturer's instructions under competent supervision and difficulties due to changes in vended products, which are beyond the control of manufacturer.

**SPECIAL NOTE:** Manufacturer is not responsible for any loss of income due to a vending machine being out of service due to a warrantable item.

This warranty is in lieu of all the other warranties, expressed or implied, including the warranty of merchantability and fitness or use, and of all other obligations or liabilities on Manufacturer's part. Manufacturer neither assumes, nor authorizes any other person to assume for it, any other liability in connection with the sale of equipment manufactured by itself. This warranty shall not apply to equipment manufactured or any part thereof which is subject to accident, negligence, alteration, abuse, misuse, or damage in shipment. The term "original purchaser", as used in this warranty, shall be deemed to mean that person for whom the equipment is originally installed.

Manufacturer is not liable for any incidental, consequential or other damages of any kind whatsoever, directly or indirectly, arising from the use of the equipment whether based upon theories of contract negligence or tort.



For Service and Customer Care:  
8:30 a.m. - 4:00 p.m. CST. Mon thru Fri  
815.297.9500 ext 160  
815.297.1758 Fax  
email: [customercare@seagamfg.com](mailto:customercare@seagamfg.com)

For Service and Customer Care:  
9:00 a.m. - 5:30 p.m. Mon thru Fri  
+44(0)1492 874010  
+44(0)1492 874644 Fax  
email: [info@seaga.co.uk](mailto:info@seaga.co.uk)

Seaga Manufacturing, Inc.  
700 Seaga Drive  
Freeport, IL 61032 U.S.A.  
[www.seagamfg.com](http://www.seagamfg.com)

Seaga UK Ltd.  
Unit 8, Caebach, Off Builders Street  
Llandudno North Wales LL30 1DR  
[www.seaga.co.uk](http://www.seaga.co.uk)

**US Version, 110 V**

Specifications	4 Wide			5 Wide		
	SP 432 Ambient	SP 430D Refrigerated	SP 735R Refrigerated	SP 540 Ambient	SP 536D Refrigerated	SP 536R Refrigerated
Height	72"	72"	72"	72"	72"	72"
Width	35"	35"	35"	39"	39"	39"
Depth	37"	37"	37"	37"	37"	37"
Floor Space	8.75 Sq. Ft.	8.75 Sq. Ft.	8.75 Sq. Ft.	9.75 Sq. Ft.	9.75 Sq. Ft.	9.75 Sq. Ft.
Packing Size	56.27 Cu. Ft.	56.27 Cu. Ft.	56.27 Cu. Ft.	62.53 Cu. Ft.	62.53 Cu. Ft.	62.53 Cu. Ft.
Voltage (AC)	110V	110V	110V	110V	110V	110V
Hertz	60Hz	60Hz	60Hz	60Hz	60Hz	60Hz
Running Amperes	1Amp.	8Amp.	8Amp.	1Amp.	8Amp.	8Amp.
Watts	300 Watts	750 Watts	750 Watts	300 Watts	750 Watts	750 Watts
Refrigerant Type	-	134a	134a	-	134a	134a
Refrigerant Charge	-	300 Grms.	300 Grms.	-	300 Grms.	300 Grms.
Shipping Weight	470 lbs.	703 lbs.	698 lbs.	528 lbs.	764 lbs.	721 lbs.

**UK Version, 220 V**

Specifications	4 Wide			5 Wide		
	SP 432 (F) Ambient	SP 430D(F) Refrigerated	SP 735R(F) Refrigerated	SP 540(F) Ambient	SP 536D(F) Refrigerated	SP 536R(F) Refrigerated
Height	183 cm	183 cm	183 cm	183 cm	183 cm	183 cm
Width	89 cm	35" 89 cm	89 cm	99 cm	99 cm	99 cm
Depth	93 cm	93 cm	93 cm	93 cm	93 cm	93 cm
Floor Space	0.812 S Mtr	0.812 S Mtr	0.812 S Mtr	0.905 S Mtr	0.905 S Mtr	0.905 S Mtr
Packing Size	1.59 Cu Mtr	1.59 Cu Mtr	1.59 Cu Mtr	1.77 Cu Mtr	1.77 Cu Mtr	1.77 Cu Mtr
Voltage (AC)	220V	220V	220V	220V	220V	220V
Hertz	50Hz	50Hz	50Hz	50Hz	50Hz	50Hz
Running Amperes	1Amp.	5Amp.	5Amp.	1Amp.	5Amp.	5Amp.
Watts	300 Watts	750 Watts	750 Watts	300 Watts	750 Watts	750 Watts
Refrigerant Type	-	134a	134a	-	134a	134a
Refrigerant Charge	-	350 Grms.	350 Grms.	-	350 Grms.	350 Grms.
Shipping Weight	317 kg	319 kg	317 kg	239 kg	347 kg	327 kg

**PHYSICAL CHARACTERISTICS**

- Finish : Powder Coat paint
- Number of Trays : 6 Standard

**ENVIRONMENT**

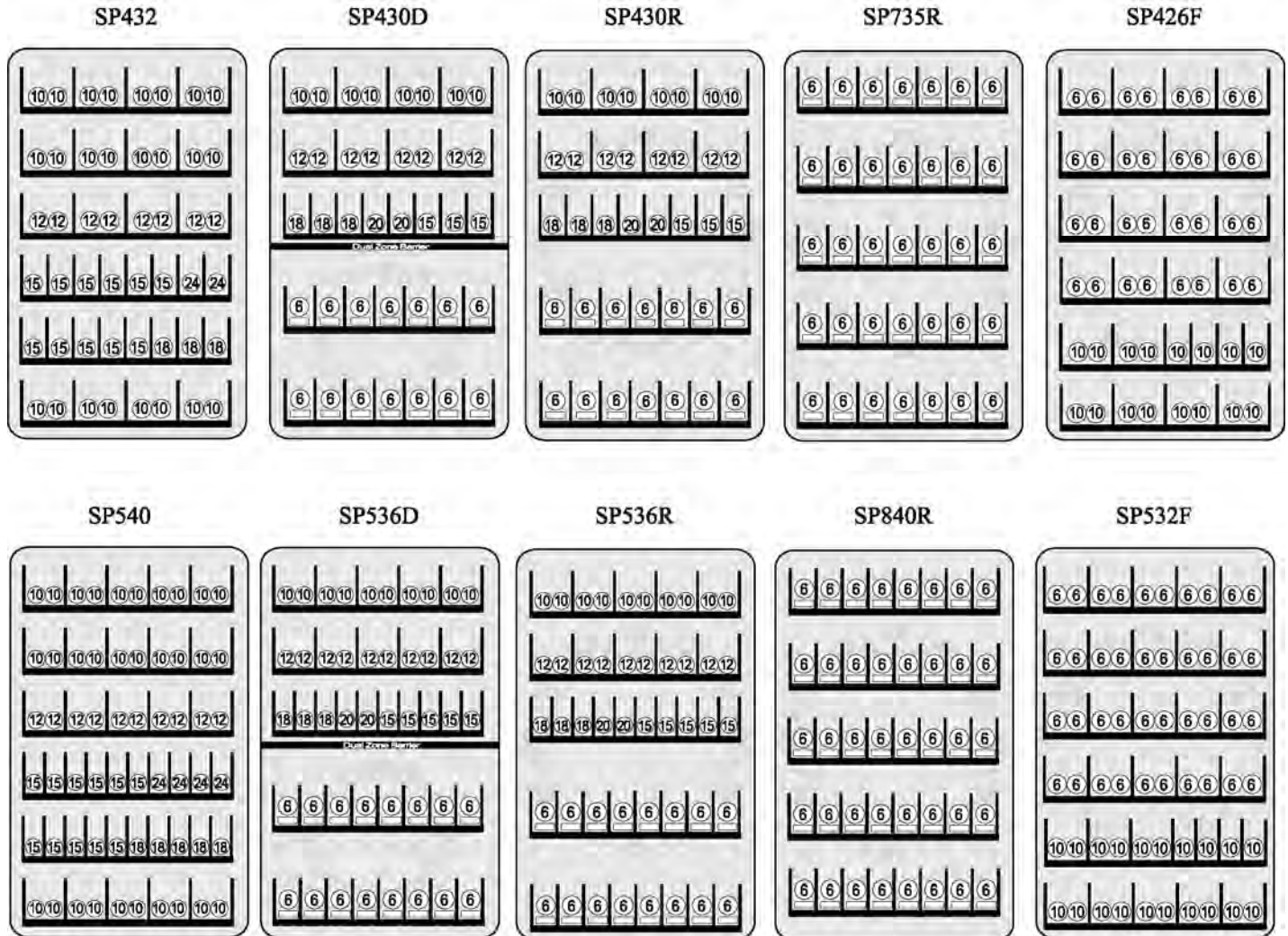
- Location Environment: Indoors only

**ELECTRICAL REQUIREMENT**

US version requires one (1) 120 VAC 12 Amps grounded outlet.  
 UK version requires one (1) 220 VAC 12 Amps grounded outlet.

**STANDARD COIL CONFIGURATION**

Subject to change without notice.



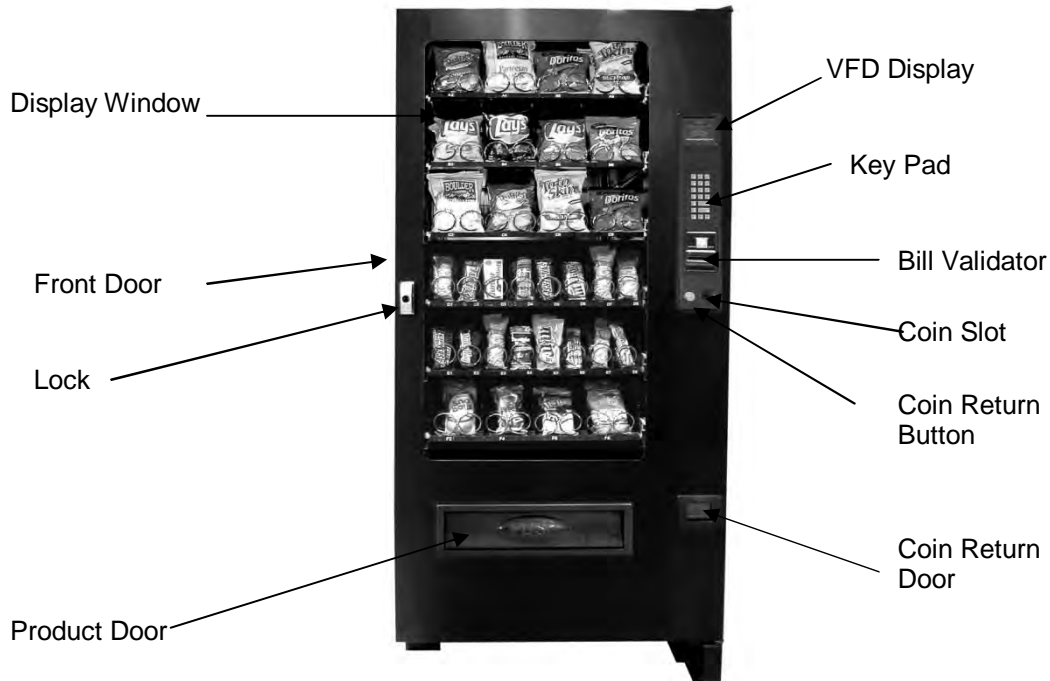
**CAUTION:** Certain procedures described in this manual require that voltage be on in the machine. Only trained personnel should perform these functions. Use extreme caution while performing the procedures marked with the voltage symbol shown here:



**CAUTION:** Certain procedures described in this manual require a qualified, trained technician to perform the particular task at hand. These procedures will be marked with the attention symbol shown here:

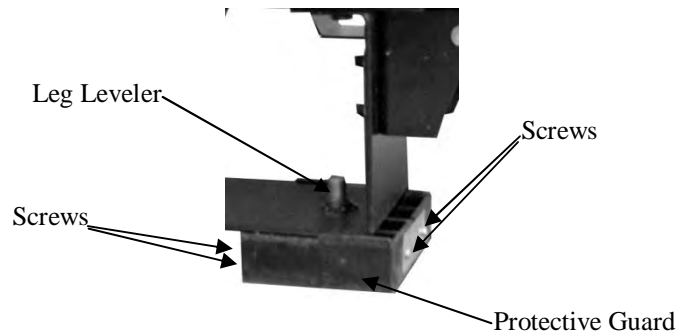


**Fig. 1**  
**Exterior View (SP432 4-Wide Snack Machine Shown)**



Protective shipping guards (Fig. 2) were installed on the leveling legs at the factory. Once the machine is placed near its final location the protective shipping guards may be removed. To remove the shipping guard, unscrew the leveling leg from the bottom until the guard is loose – a few turns only. The guard is held together with four phillips head screws and two brackets. Remove the screws and the guard will split in half for removal.

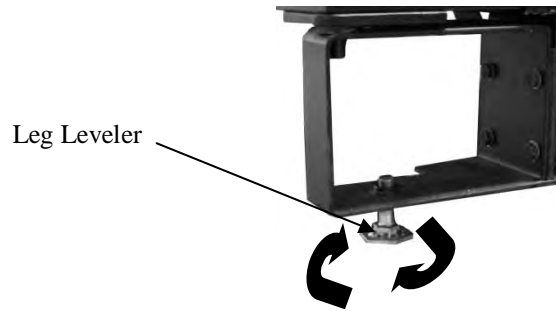
**Fig. 2**



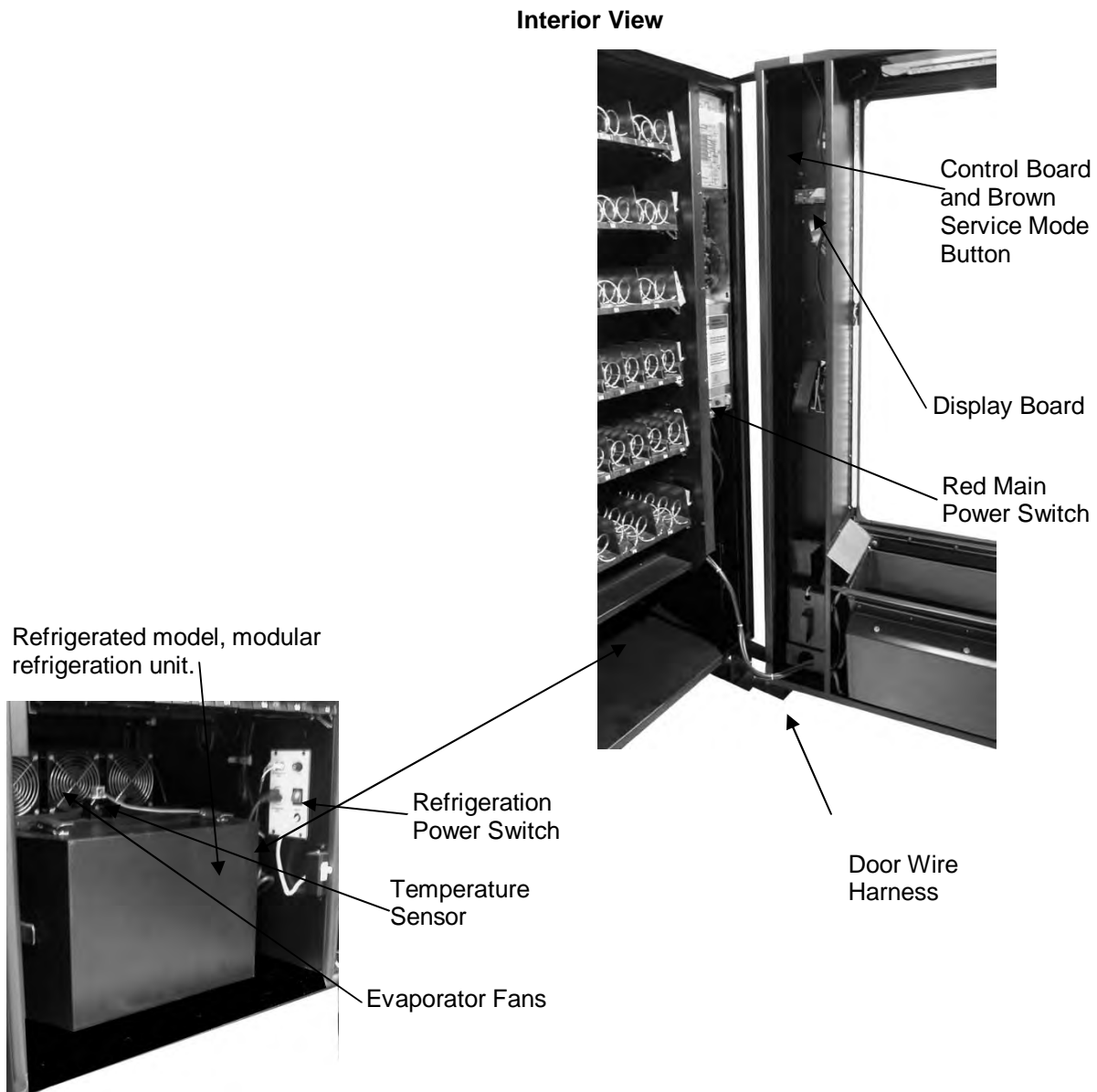
Now place the machine into its final location. Using a level on the top of the machine, adjust the five leveling legs, if necessary, for proper level both side to side and front to back. A good point to keep in mind is the shorter the leveling legs are kept to achieve proper leveling the more stable the machine will be.

Proper leveling is also necessary to allow easy opening and closure of the vending machine door and to insure proper vending operation.

**Fig. 3**



**Fig. 4**



CAUTIONS**Your vendor is intended for indoor use only.**

Your vendor must be set on a level, well-supported location.  
Always unload vendor before transporting it.  
Remove all wire ties and protective sheeting prior to vending.

**CAUTION!**

Procedures marked in this manual with the symbol shown to the left require power to the machine, which means that there is a shock hazard.

**CAUTION!**

It is important that this machine is hooked up to the proper voltage. Verify the voltage before connecting the machine to a wall outlet.

**CAUTION!**

Different countries may have different power arrangements. Insure that the machine is properly grounded before operating.

**CAUTION!**

If the power cord is damaged, it must be replaced by the manufacturer, authorized service agent or a similarly qualified person to avoid electrical hazards.

**ATTENTION!**

This vending machine is very heavy. Ensure that sufficient personnel are available for lifting or transporting the machine. Use proper lifting procedures and equipment.

**CAUTION!**

Certain components of this machine are sensitive to static electricity. Precautions for handling sensitive devices should be observed when handling these items.

**ATTENTION!**

Refrigerated models need air flow. Leave at least 6" between the back of the vending machine and the wall. Condenser cooling air is taken in the bottom and exhausted out the back of the machine. Clean the condenser once every two weeks or more often for high-particle locations.

## DOOR CLEARANCE

Please leave 7" clearance on the right side of the machine for the door to open and extend past the cabinet side. See clearance requirements above for refrigerated units.

## LOADING PRODUCTS

To present your product in as an attractive and professional manner as possible, do not load any damaged items, and make sure items are facing forward for easy identification by your customer.

Note: The size of the item being vended must be larger than the Helix Coil, but smaller than the Product Chute, to vend correctly. Never force an oversized item into the Helix Coil or Product Chute, nor attempt to vend an item that is smaller than the Helix Coil as this will create problems and deter customers. (Fig.1)

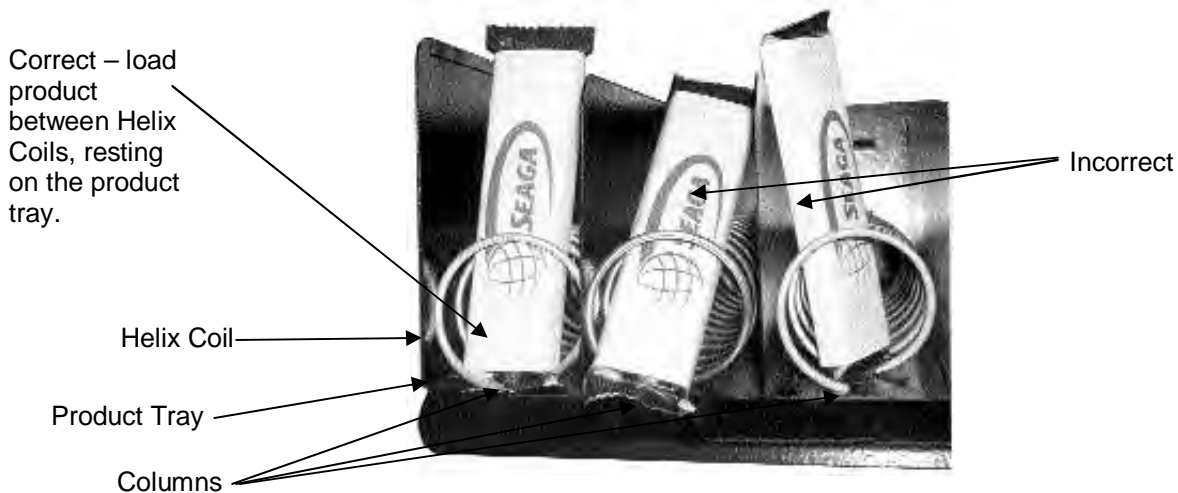
### 1. To Load Product:

- A.) Use the release latches and pull the desired Product Tray all of the way forward. Product Tray will tilt down or can be removed and placed on the floor or a table.  
**Note: Pull out only one (1) Product Tray at a time.**
- B.) Place product in proper size Helix Coil. Note: Bottom of product must rest on the Product Tray and not on the Helix Coil. (Fig. 12) Load each Product Chute from front to back. Note: Do not leave any spaces between items.
- C.) Once Product Tray is loaded, lift the front of the tray to level and push it back in. Repeat above steps until all Product Trays are fully loaded.
- D.) After loading the product, if you have removed the tray to do so, place the Tray in the cabinet by aligning the wheels in the guide rails. Clear the wire harness To the side so that it is not interfering with the tray below.

To increase the length of the Helix Coil, white plastic Product Pushers can be snapped on the end. A supply of Product Pushers are provided in the vendors hardware bag.

**Special Note:** We suggest that you always partially fill the vendor with product and perform at least five (5) test vends. Test vends can be performed easily by entering Service Mode and running "Individual Motor Testing". (See: Keypad and LED Display, Individual Motor Testing.)

Fig. 5



## PRODUCT PUSHERS

Product pushers assist in moving the top of the product forward while it is being vended on the bottom, helping it fall smoothly from the shelf. Product pushers are also good for products that have the wrapper flaps on the ends of the package. Packaging such as this benefits from the extra momentum from the product pushers to keep the flaps from



hanging up the product on the spiral. The pusher is installed approximately 15mm from the front end of the coil with the tab extending forward (see Fig. 6). Locate the pusher in its proper position, hold it against the coil wire and push the semi-circular part around the coil wire. Note: Boxed items will not need a product pusher.

Figure 6 – Product Pusher Installation



### **LOADING BAGGED OR BOXED ITEMS**

When vending small bagged items in the 8 or 10 selection trays can be a problem when the products are not loaded properly. The flap edges of some products may get trapped under the spiral and cause the product to “hang up”. It is recommended that the bottom flap of this type of packaging be folded forward and up (Fig. 4) next to the product when loading. This type of packaging also lets the product settle to the bottom, so using the wider spirals is also recommended.

### **PRODUCT STABILIZERS**

Models with beverage vending can accommodate various sizes of cans and bottles. Product stabilizers have been included with your machine, carefully wrapped, and inserted into the cabinet. Product stabilizers are not absolutely necessary, but do assist the product in several ways: 1.) They present the product in an upright manner, which attracts more attention and will increase your sales and 2.) They keep the product steady as it moves forward during vend cycles.

To install the product stabilizers for beverage vending, first pull out one of the beverage trays. Note the silver tab at the back of the tray, inside the coil (Fig. 7).

Fig. 7 – Product Stabilizers



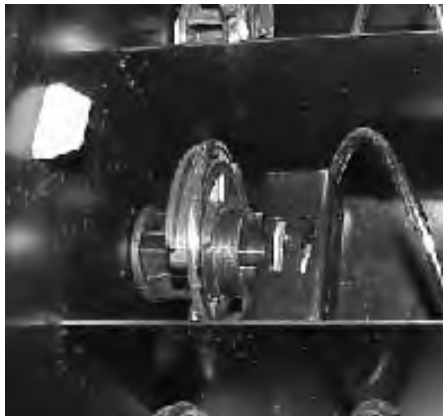
The product stabilizers (one for each selection) should be slid inside the coil and the silver tab at the back of the tray should be inserted into the slot on the end of the platform. Note that there are two slots at the end of the platform; the rear-most slot should be used for this application. (Fig. 8)

Fig. 8 – Product Stabilizers

Installed, side view.



Installed, Top View



Installed



Installed, Front View



### LOCK

Your vendor has one Lock, more commonly known as T-handle lock. To unlock the front door, insert key and turn clockwise  $\frac{1}{4}$  turn. When unlocked the 'T' of the Lock will pop out from its base. Turn the 'T' 15 to 20 times counter clockwise to unlock the door. To Lock the door turn the 'T' handle clockwise 15 to 20 times and then push the 'T' inside the Lock to lock the door. Key can now be removed. Note: Do not over-tighten when locking – this could strip the threads and damage your machine.

### REFRIGERATION

If you purchased a refrigerated model, please see special information throughout the manual regarding refrigeration, settings and other information. The refrigeration system consists of Compressor, Relay circuit, Accumulator, condenser, condenser fan, evaporator, evaporator fans and air duct. The entire refrigeration system is modular and has a separate internal power cord, which is plugged in on the plug point provided at the bottom area below the last tray. The power switch has to be turned ON in order to start up the refrigeration system. There is a door switch that controls the refrigeration system ON and OFF condition. When the door is opened, the door switch is not depressed and the refrigeration system shuts OFF. When the door is closed, the switch is activated and the evaporator fans starts turning. There will be a delay before compressor starts running after the door closure.

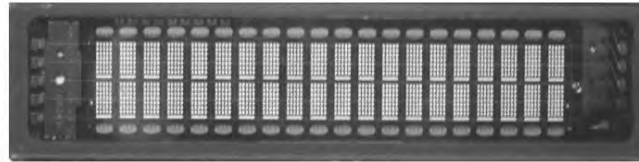
There is a vent on the cabinet back to blow the air from condenser. The inlet vent is at the bottom of the cabinet in front of the condenser. The condenser has to be cleaned regularly. The recommended frequency is once every two weeks. There are 6 clips around the front of the refrigeration module that has to be un-hooked in order to remove the front door of the refrigeration module. This will provide the access to the condenser. Either using fin-comb or a brush, clean the lint in between the condenser fins. Note: Be careful not to bend the fins – this could restrict airflow and damage your machine.

The compressor and the relay circuit, condenser fan motor and drain pan can be accessed in the same manner by removing the front door. The refrigeration system has to be unplugged and the module has to slide completely outside in order to gain access to these components.

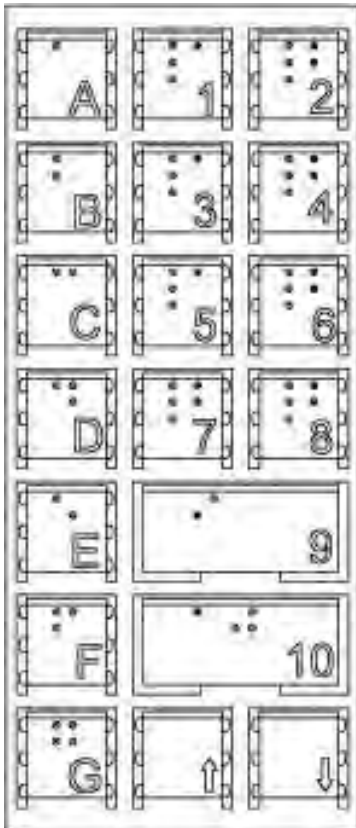
**DISPLAY**

The VFD Display (Fig. 9) is a 2 x 20 Text Display. The display shows the customer the amount of money entered into the vendor and the cost of their selection among other information as programmed. It shows the operator the Service Mode functions for setting the various functions of the vendor.

Fig. 9

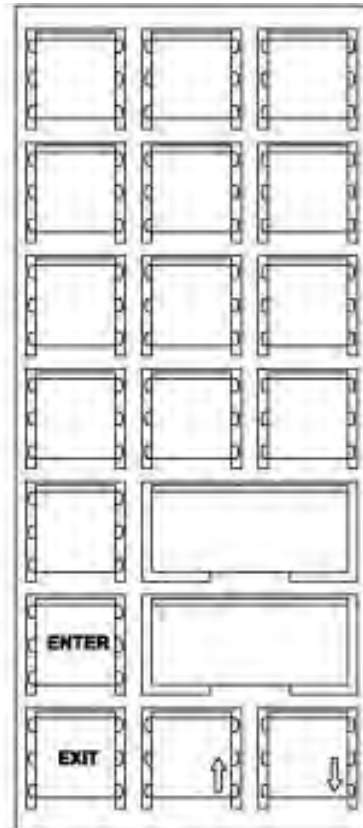


**SERVICE MODE**



Sales mode keypad

F = ENTER  
 G = EXIT  
 ↑ = Scroll Up  
 ↓ = Scroll Down



Four Service mode Button of keypad

**Navigation of the Service Mode Menu**

Button	Definition
↑ <b>Button</b>	This key is used to increase a numeric value, or move forward through the various service mode functions.
↓ <b>Button</b>	This key is used to decrease a numeric value or move backwards through the various service mode functions.
<b>F Button</b>	This key is used to confirm, accept, or enter into a service mode function. In the Test Key pad Mode it displays a '0' Key on the VFD
<b>G Button</b>	This key is used to EXIT SERVICE or LEAVE a service mode function.

## Entering Service Mode

To enter into service mode open the vendor door and Press the Brown Menu Service Mode Button (Fig. 10). After pressing the Service mode switch the controller will beep twice and the display will change to show **“Service Menu”** on the first line and **“Prices”** on the second line (Fig. 11). At this time you can use the keypad on the front of the machine to move through the various service mode MENUS.

Fig. 10 - Service Mode Button

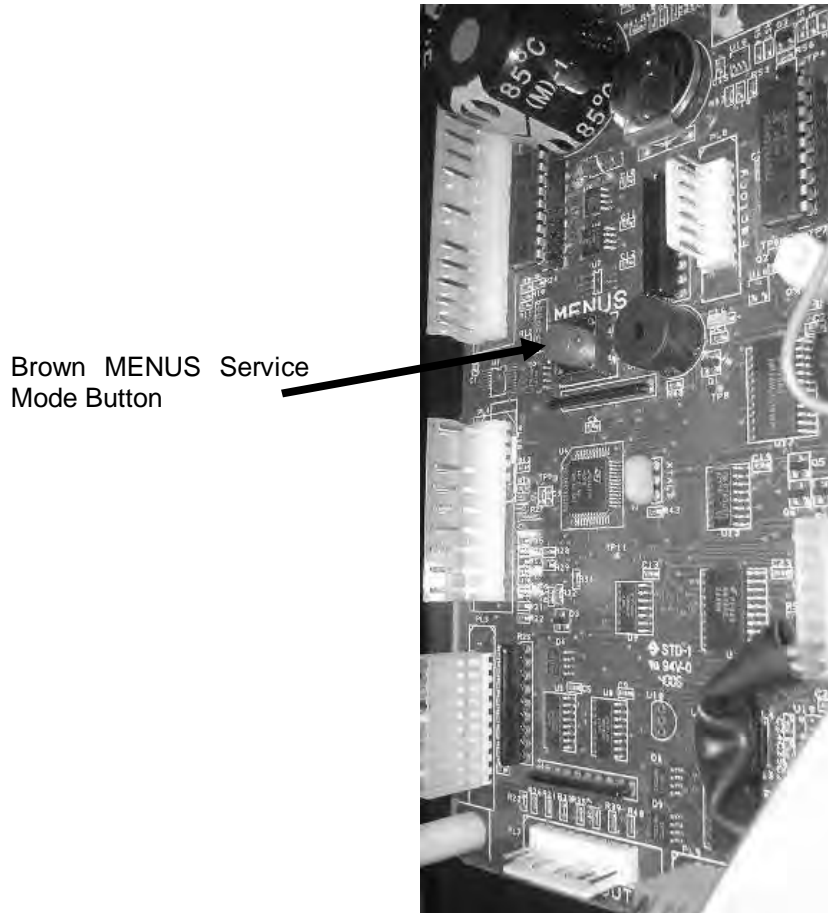


Fig. 11 – VFD Display while in Service Mode. The Prices menu is the first sub-menu.



## Exiting service mode

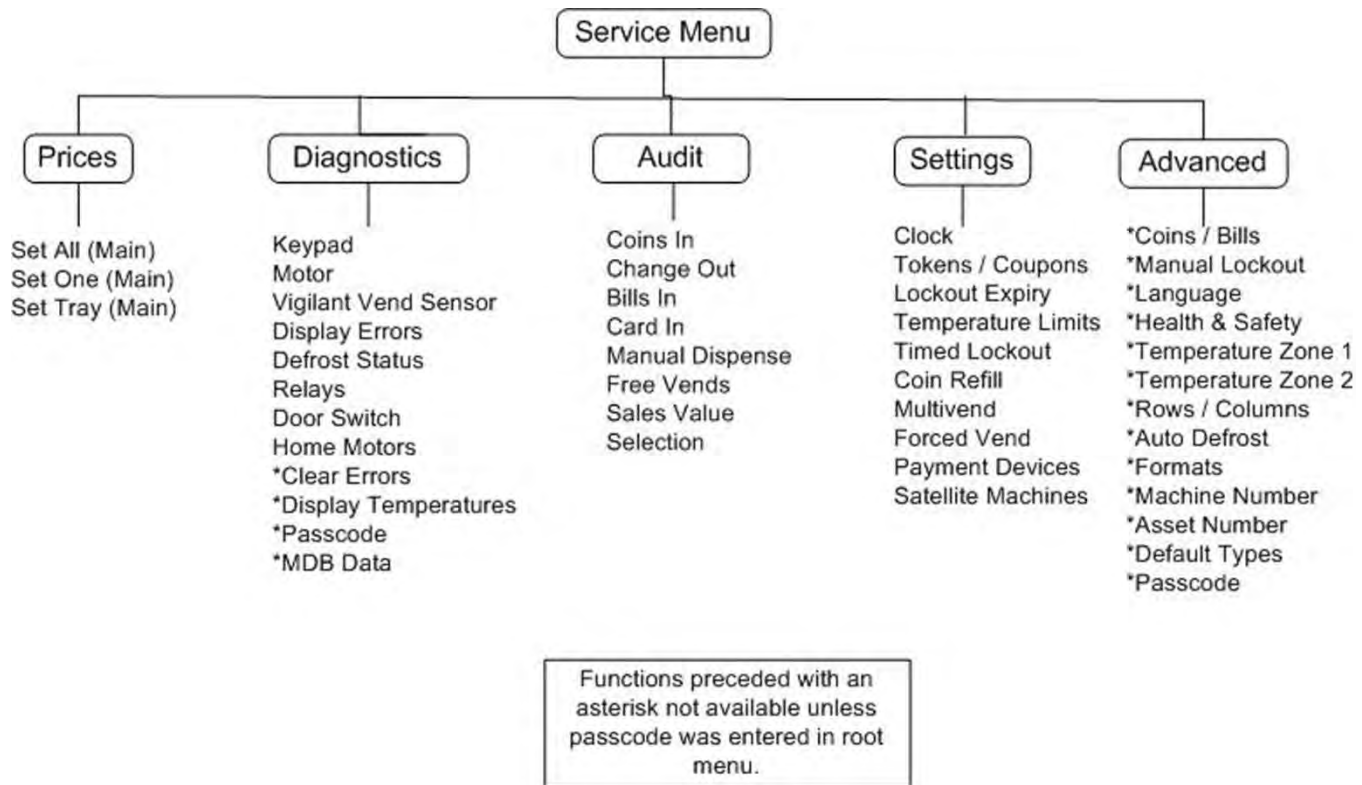
The controller will remain in service mode as long as the user keeps using the keypad to move through the various service mode MENUS. The controller will automatically exit service mode and return to sales mode if any of the following occur:

- 1) The user is inactive for more than 3 minutes
- 2) The user presses the EXIT key (G).

When service mode is exited the beeper will sound twice and the installed firmware version will be shown on the display for three seconds, then the controller will revert to sales mode.

## Service mode MENUS

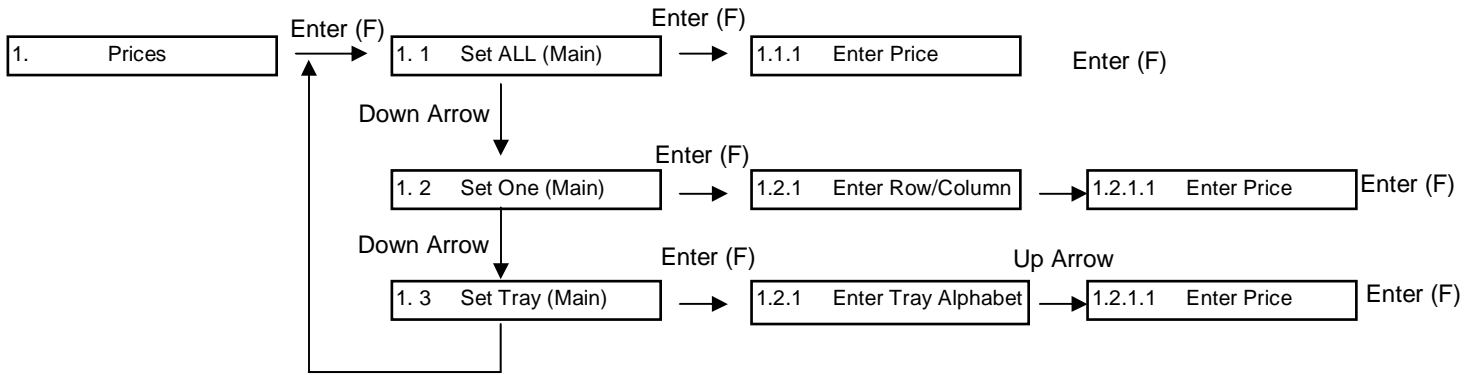
The chart below shows the sub-menus while in Service mode:



## PRICES SUB-MENU

The Prices sub-menu allows you to set prices in three different ways – Set ALL, Set ONE, Set Tray. Set ALL will allow you to set all of selections in the machine to the same price. Set ONE will allow you to set one individual selection of your choosing. Set Tray will allow you to set an entire tray to the same price.

Using these available options will save you time – if the majority of your price is, for example, set at \$1, use the Set ALL sub-menu to set all prices to \$1. You can then go back and set individual prices for certain selections as needed.



In order to enter the price, Press the corresponding number. For example, if the Price of a Selection is \$0.75, then Press “7” and “5”. Press F to accept the value; G to exit to the main menu. *Note: Discount prices can only be set using a Seaga Smart Card.*

**Diagnostics** - The Diagnostics menu is used to test various features of the machine. Certain critical features of the machine are protected by a pass code provided to the operator to prevent inadvertent modifications to the machine.

## DIAGNOSTICS SUB-MENU

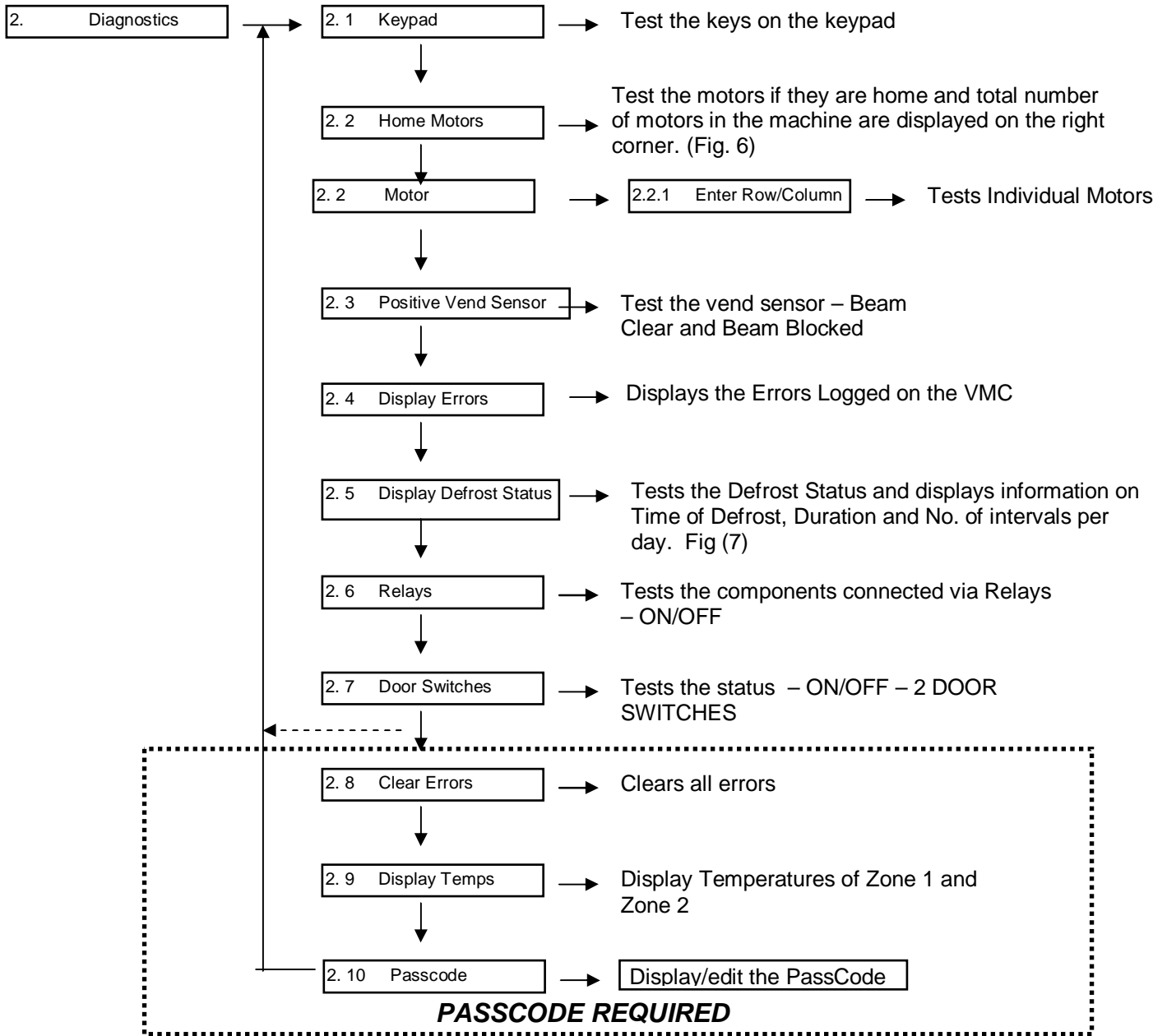


Fig. 12

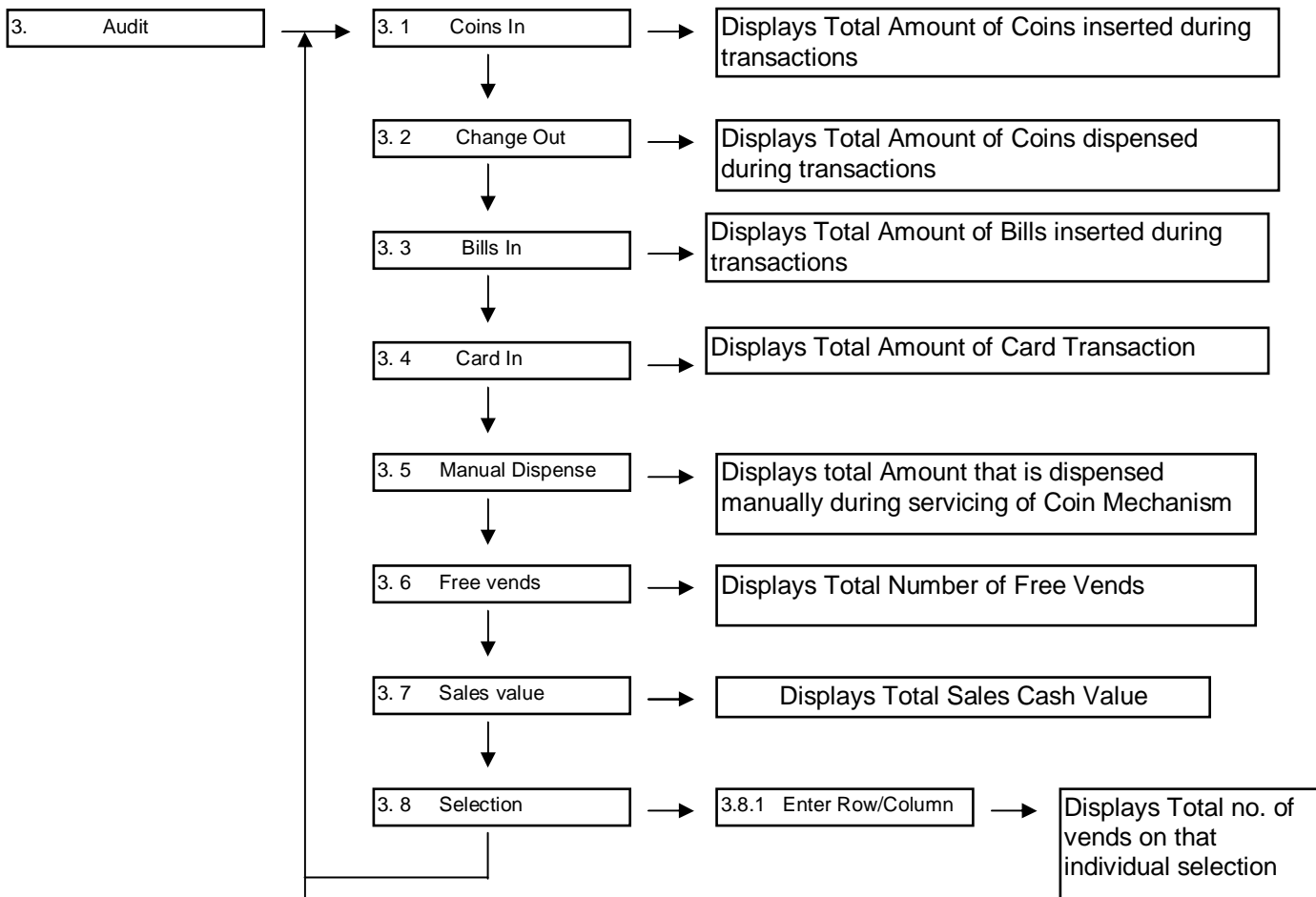


Fig. 13



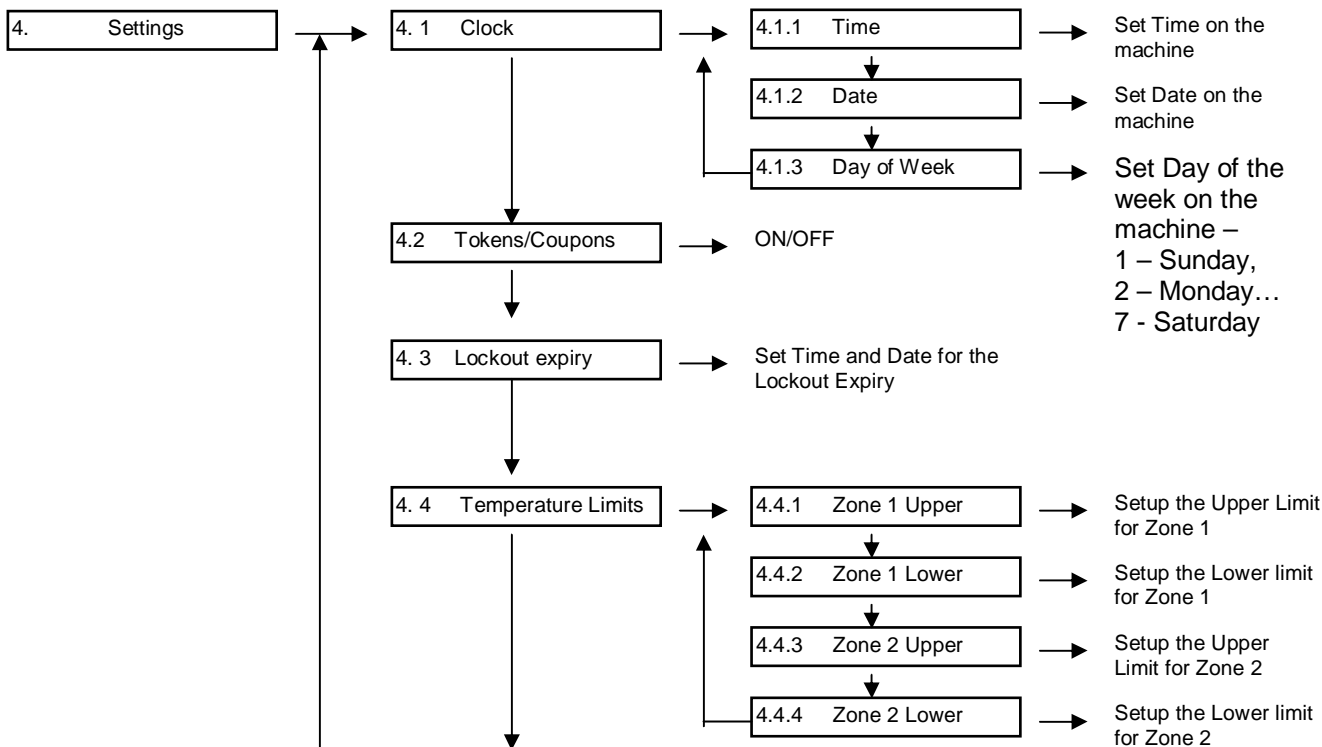
**AUDIT MENUS** -The Audit Menu is used to track the machine operation in all aspects but not limited to the transactions.

**AUDIT SUB-MENU**



**SETTINGS** - This menu is used to Setup the features of the machine.

**SETTINGS SUB-MENU**





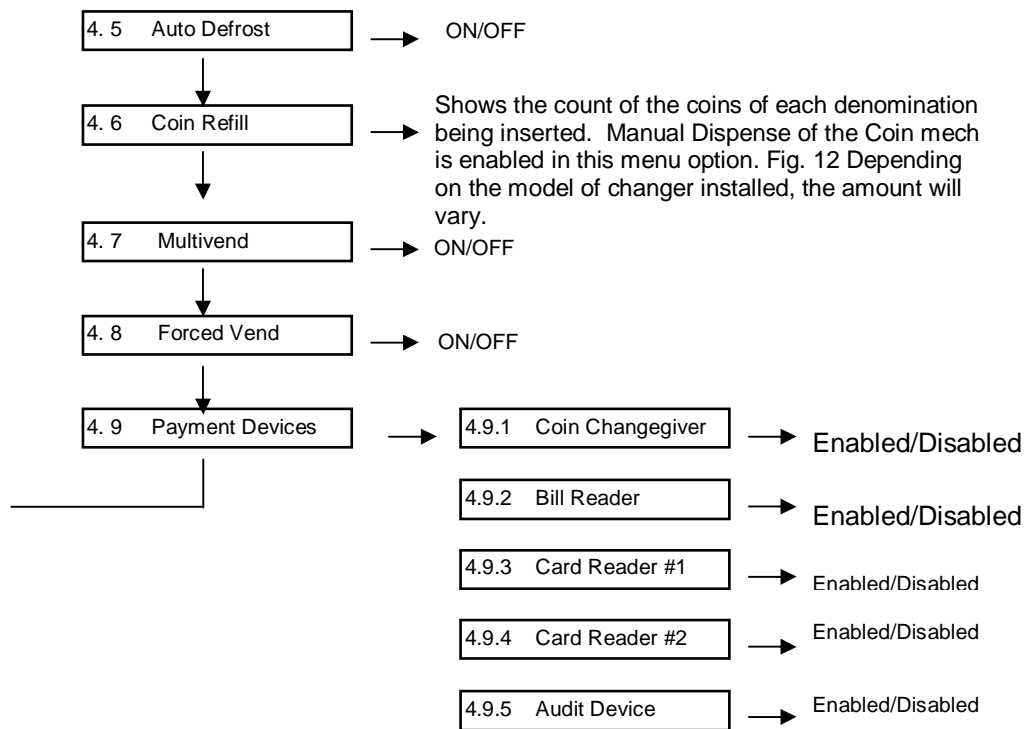
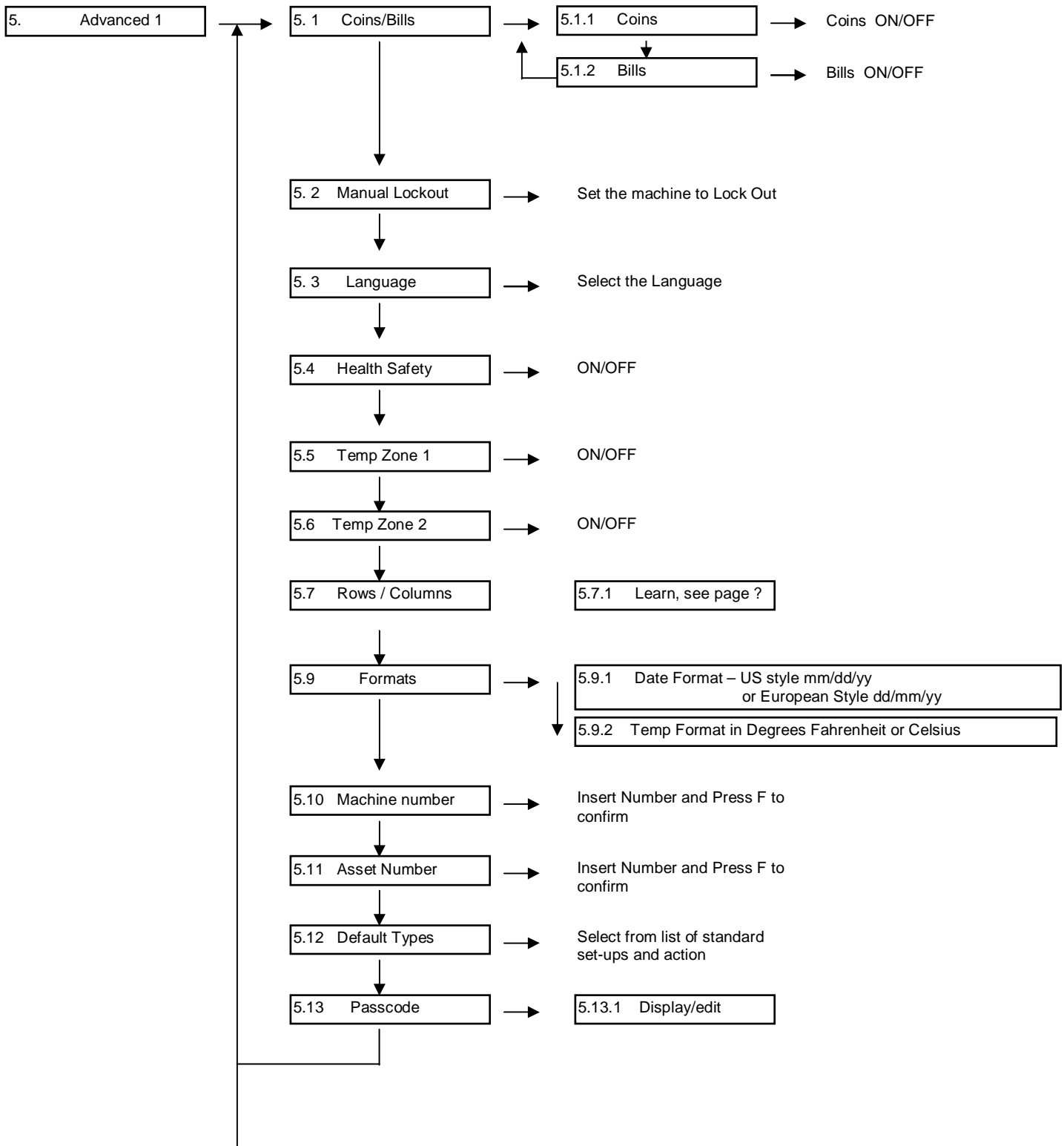


Fig. 14



**ADVANCED** - This menu is used to setup the Advanced Settings. Please enter the Pass Code in order to access this menu.

**ADVANCED SUB-MENU**



**EXIT SERVICE MODE:** Press “G” to Completely Exit from the Service Menus.

The Seaga Smartware setup utility enables Setup smart cards to be used to set the configuration of the new generation of Seaga vending machine controller boards. The utility works in conjunction with a USB smart card reader.

- **System Requirements**

- Seaga Smartware CD
- Approved USB Card Reader
- Seaga Smart Cards
- PC with the following specification:

	Minimum	Recommended
Processor	Pentium 200MHz Processor	Pentium P4 1000MHz or better
RAM	128M byte	> 256M byte RAM
Free Hard Disc Space	20Mbyte	> 100Mbyte
Graphics	800x600 16 colour SVGA	1024 x 768 256 colour SVGA
Operating System	Windows 98SE	Windows Me, 2000, XP or Vista
CD-ROM	Yes	Yes
USB port	One	More than One

- **Software Installation**

- (i) Installation of Card Reader Drivers

Either :

- Insert the CD into the CD ROM drive
- Select the "Install Card Reader Driver" option

Or (Windows XP / Vista only):

- Insert the CD into the CD ROM drive
- Plugg the card reader into the PC and follow the instructions in the "Add New Hardware" wizard. The Card Reader drivers are located in the **/drivers/** folder on the CD.

Or :

- Run the programme "**setup.exe**" in the "**/2/**" folder on the CD and follow the instructions.

- (ii) Installing the Smartware Application

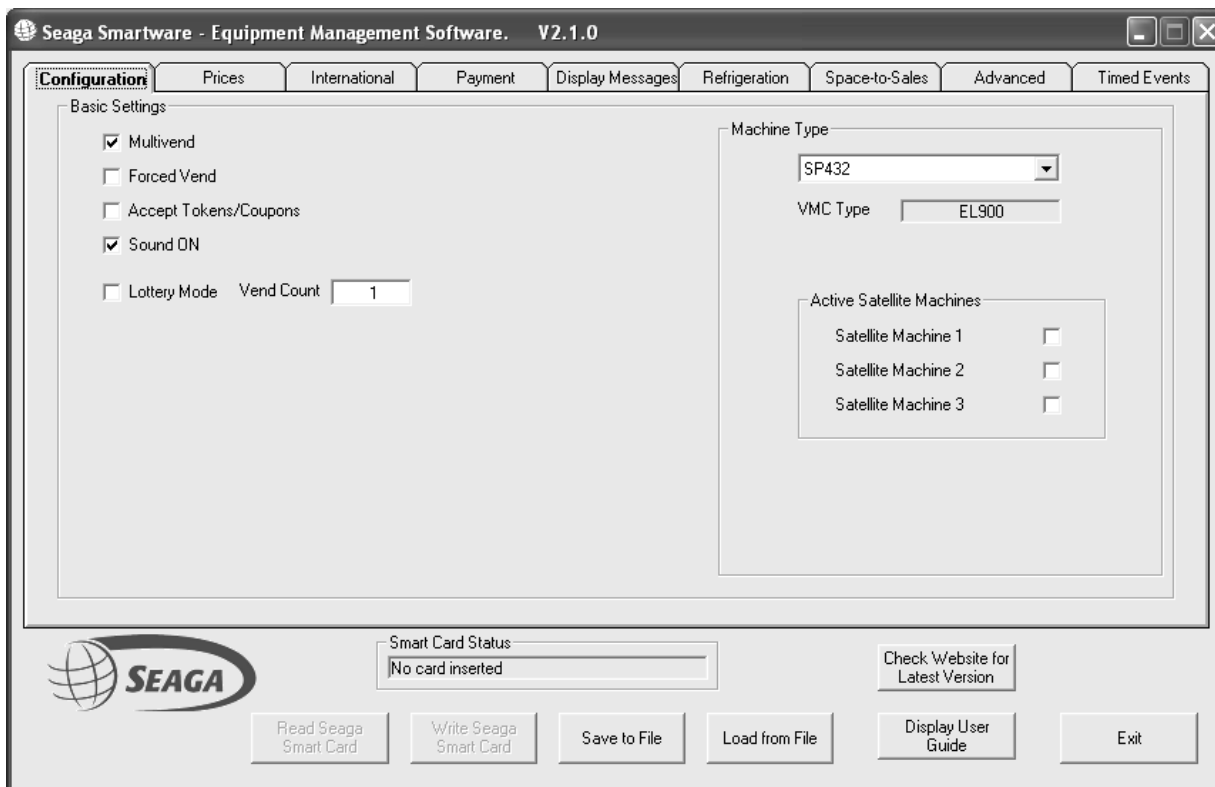
Either :

- Insert the CD into the CD ROM drive
- Select the "Install Seaga Smartware" option

Or :

- Run the programme "**setup.exe**" in the top level folder on the CD and follow the instructions.

## CONFIGURATION PAGE



### General Operations

**Read Seaga Smart Card** – read an existing smart card

**Write Seaga Smart Card** – programme a card with the current settings

**Save to File** – save the complete settings to a text file

**Load from File** – restore previously saved configurations

**Check Website for Latest Version** – Hyperlink to [www.seagamfg.com/smartware/index.html](http://www.seagamfg.com/smartware/index.html)

**Display User Guide**

– Hyperlink to [www.seagamfg.com/smartware/Seaga Smartware Guide.pdf](http://www.seagamfg.com/smartware/Seaga%20Smartware%20Guide.pdf)

**Exit** – close the utility programme

**Card Status** – shows the status of the card reader

No card inserted	(Read and Write Card buttons disabled)
Seaga 256K smart card	Standard smart card inserted
Seaga 512K smart card	Alternate smart card inserted

### Notes

If an Audit or a Temperature Logging Card card type being read the data will be saved to a file once the read is complete. There is a prompt for the file name and an option to clear the card after it has been saved to the file. Refer to Appendix 1 for the file formats.

## CONFIGURATION PAGE (continued)

Seaga Smartware - Equipment Management Software. V2.1.0

Configuration | Prices | International | Payment | Display Messages | Refrigeration | Space-to-Sales | Advanced | Timed Events

Basic Settings

Multivend  
 Forced Vend  
 Accept Tokens/Coupons  
 Sound ON  
 Lottery Mode    Vend Count:

Machine Type

Machine Type: SP432  
VMC Type: EL900

Active Satellite Machines

Satellite Machine 1   
Satellite Machine 2   
Satellite Machine 3

Smart Card Status: No card inserted

Check Website for Latest Version

Read Seaga Smart Card    Write Seaga Smart Card    Save to File    Load from File    Display User Guide    Exit

### Machine Selection / Basic Settings

Use the **Machine Type** “pull-down” to select a standard machine configuration, or select a specific VMC type.

**Multivend**, **Forced Vend**, **Accept Tokens/Coupons** and **Sound ON** – check the option to enable the corresponding feature.

**Lottery Mode** – check this option and enter a “**Vend Count**” value to allow a free selection, every “**Vend Count**” vends.

**Satellite Machine n** – check the box to allow the VMC to work with the corresponding Satellite machine.

When a Satellite machine type (VMC type EL906) is selected there is an option to configure the machine as **Satellite 1**, **Satellite 2** or **Satellite 3**.

**Note** : some features described in this guide are not available on all VMC configurations. If a particular item is “greyed out” or not shown, it is not available for the current machine.

## PRICES PAGE

Seaga Smartware - Equipment Management Software. V2.1.0

Configuration Prices International Payment Display Messages Refrigeration Space-to-Sales Advanced Timed Events

Main Prices

A2	75	A4	75	A6	75	A8	75								
B2	75	B4	75	B6	75	B8	75								
C2	75	C4	75	C6	75	C8	75								
D1	75	D2	75	D3	75	D4	75	D5	75	D6	75	D7	75	D8	75
E1	75	E2	75	E3	75	E4	75	E5	75	E6	75	E7	75	E8	75
F2	75	F4	75	F6	75	F8	75								

Price Bank: Main Prices Machine: Main Machine

Set All Prices ALL Price: 100

Smart Card Status: No card inserted

Check Website for Latest Version

Read Seaga Smart Card Write Seaga Smart Card Save to File Load from File Display User Guide Exit

Depending on the machine configuration, up to 80 Price Boxes will be displayed for the machine.

To set a particular **price** type the value, in cents/pence, into the corresponding **price box**.

To set **ALL** the prices to the same amount, enter the amount in the **ALL Price** box and click the **Set All Prices** button.

The VMC can hold prices for the Main Machine and also up to three Satellite (MDB USD) machines – prices for the satellite machines can be accessed using the **Machine** “pull down” menu.

Individual selections may be named – refer to the **Text Messages** page for more details

## PRICES PAGE (continued)

Seaga Smartware - Equipment Management Software. V2.1.0

Configuration | **Prices** | International | Payment | Display Messages | Refrigeration | Space-to-Sales | Advanced | Timed Events

Discount Prices

A2	40	A4	40	A6	40	A8	40								
B2	40	B4	40	B6	40	B8	40								
C2	40	C4	40	C6	40	C8	40								
D1	40	D2	40	D3	40	D4	40	D5	40	D6	40	D7	40	D8	40
E1	40	E2	40	E3	40	E4	40	E5	40	E6	40	E7	40	E8	40
F2	40	F4	40	F6	40	F8	40								

Price Bank: Discount Prices | Machine: Main Machine | Set All Prices | ALL Price: 100

Smart Card Status: No card inserted | Check Website for Latest Version

Read Seaga Smart Card | Write Seaga Smart Card | Save to File | Load from File | Display User Guide | Exit

### Discount Prices

Select **Discount Prices** using the **Price Bank** pull-down.

The VMC can operate at discounted prices between the **Discount Start Time** and **Discount End Time** points - refer to the "Timed Events" section.

## PRICES PAGE (continued)

Seaga Smartware - Equipment Management Software. V2.1.0

Configuration | **Prices** | International | Payment | Display Messages | Refrigeration | Space-to-Sales | Advanced | Timed Events

Meal Deals

	Price	Selection 1	+ Selection 2	+ Selection 3	+ Selection 4
GG1	200	A4	D8	D7	
GG2	200	D1	BA10		
GG3	0				
GG4	0				
GG5	0				
GG6	0				
GG7	0				
GG8	0				
GG9	0				
GG10	0				

Price Bank: Meal Deals (dropdown)  
Machine: Main Machine (dropdown)

Set All Prices | ALL Price: 100

Smart Card Status: No card inserted

Check Website for Latest Version

Read Seaga Smart Card | Write Seaga Smart Card | Save to File | Load from File | Display User Guide | Exit

### Meal Deals

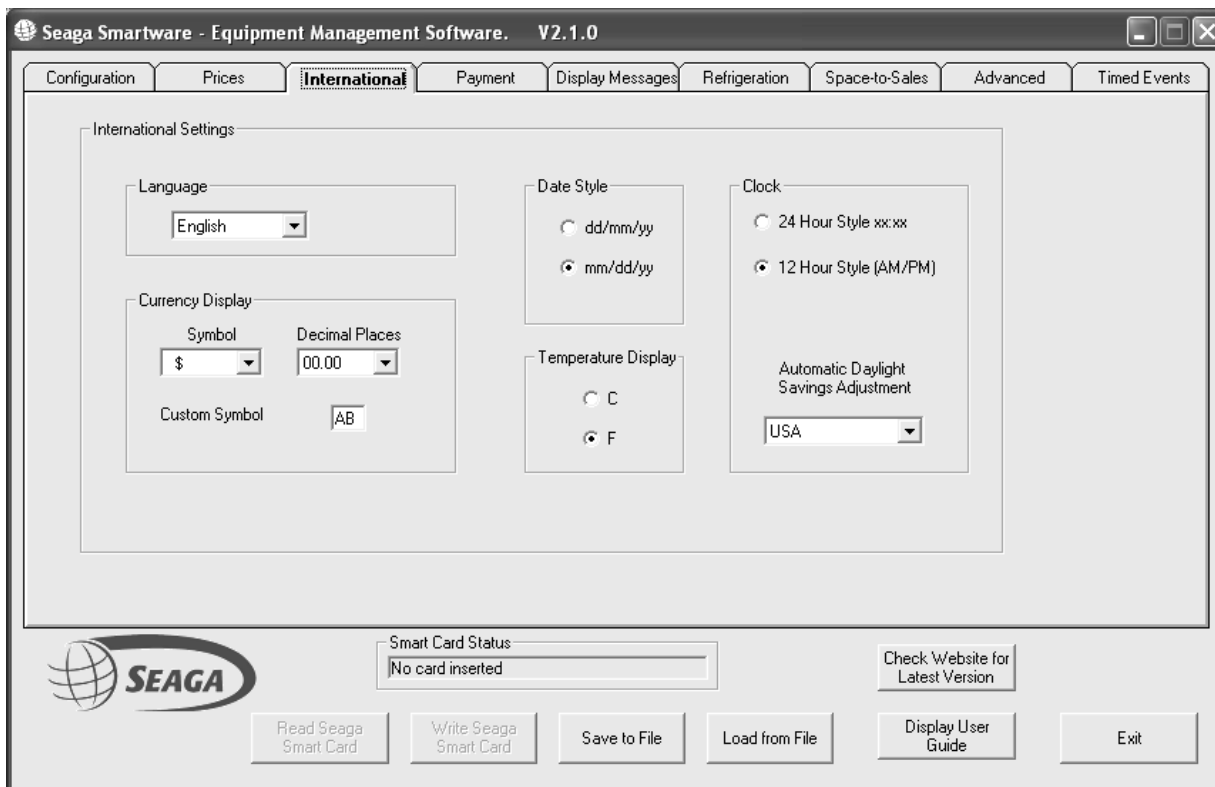
These are multiple selections that may be offered at a discount price for the group of selections.

Meal deals are selected using the special selection prefix “GG” followed by the 1 – 10 key. The Meal Deal price is charged to the customer and multiple products are vended as specified.

Each of the 10 meal deals can have an individual price, followed by a list of selections that make up the deal. Each deal can comprise up to 4 selections which may be from the Main machine, or from Satellite machines. In the example above meal deal GG2 comprised selection D1 from the main machine plus selection A10 from the second satellite machine.



## INTERNATIONAL PAGE



### Language

Select the default language for the display using the pull-down list. One language option is **EEPROM**. This language bank may be edited for special configurations and non-supported languages. Refer to the **Text Messages** page for more details.

### Currency Display

Choose the desired currency **Symbol** and the number of **Decimal Places** to be displayed. If the required currency symbol is not in the options, choose **Custom** and type in two characters in the **Custom Symbol** box.

### Date Style

Choose between **mm/dd/yy** and **dd/mm/yy** styles

### Temperature

Choose between displaying Centigrade and Fahrenheit. **IMPORTANT**: Check the values on the **Refrigeration Page** AFTER changing the Temperature scale.

### Clock

Choose between 24 hour and 12 hour modes to be displayed.

Select the **Daylight Saving Time** option for automatic summer/winter changes in the **USA** and the **UK/Europe** if required.

## PAYMENT PAGE

Seaga Smartware - Equipment Management Software. V2.1.0

Configuration Prices International **Payment** Display Messages Refrigeration Space-to-Sales Advanced Timed Events

**Coin Changegiver**

	Enabled	Enabled in Exact Change
Coin 1	<input checked="" type="checkbox"/>	<input checked="" type="checkbox"/>
Coin 2	<input checked="" type="checkbox"/>	<input checked="" type="checkbox"/>
Coin 3	<input checked="" type="checkbox"/>	<input checked="" type="checkbox"/>
Coin 4	<input checked="" type="checkbox"/>	<input checked="" type="checkbox"/>
Coin 5	<input checked="" type="checkbox"/>	<input checked="" type="checkbox"/>
Coin 6	<input checked="" type="checkbox"/>	<input checked="" type="checkbox"/>
Coin 7	<input checked="" type="checkbox"/>	<input checked="" type="checkbox"/>
Coin 8	<input checked="" type="checkbox"/>	<input checked="" type="checkbox"/>
Coin 9	<input checked="" type="checkbox"/>	<input checked="" type="checkbox"/>
Coin 10	<input checked="" type="checkbox"/>	<input checked="" type="checkbox"/>
Coin 11	<input checked="" type="checkbox"/>	<input checked="" type="checkbox"/>
Coin 12	<input checked="" type="checkbox"/>	<input checked="" type="checkbox"/>
Coin 13	<input checked="" type="checkbox"/>	<input checked="" type="checkbox"/>
Coin 14	<input checked="" type="checkbox"/>	<input checked="" type="checkbox"/>
Coin 15	<input checked="" type="checkbox"/>	<input checked="" type="checkbox"/>
Coin 16	<input checked="" type="checkbox"/>	<input checked="" type="checkbox"/>

Manual Dispense ON

**Bill Reader**

	Enabled	Use Escrow	High Security
Bill 1	<input checked="" type="checkbox"/>	<input checked="" type="checkbox"/>	<input checked="" type="checkbox"/>
Bill 2	<input checked="" type="checkbox"/>	<input checked="" type="checkbox"/>	<input checked="" type="checkbox"/>
Bill 3	<input checked="" type="checkbox"/>	<input checked="" type="checkbox"/>	<input checked="" type="checkbox"/>
Bill 4	<input checked="" type="checkbox"/>	<input checked="" type="checkbox"/>	<input checked="" type="checkbox"/>
Bill 5	<input checked="" type="checkbox"/>	<input checked="" type="checkbox"/>	<input checked="" type="checkbox"/>
Bill 6	<input checked="" type="checkbox"/>	<input checked="" type="checkbox"/>	<input checked="" type="checkbox"/>
Bill 7	<input checked="" type="checkbox"/>	<input checked="" type="checkbox"/>	<input checked="" type="checkbox"/>
Bill 8	<input checked="" type="checkbox"/>	<input checked="" type="checkbox"/>	<input checked="" type="checkbox"/>
Bill 9	<input checked="" type="checkbox"/>	<input checked="" type="checkbox"/>	<input checked="" type="checkbox"/>
Bill 10	<input checked="" type="checkbox"/>	<input checked="" type="checkbox"/>	<input checked="" type="checkbox"/>
Bill 11	<input checked="" type="checkbox"/>	<input checked="" type="checkbox"/>	<input checked="" type="checkbox"/>
Bill 12	<input checked="" type="checkbox"/>	<input checked="" type="checkbox"/>	<input checked="" type="checkbox"/>
Bill 13	<input checked="" type="checkbox"/>	<input checked="" type="checkbox"/>	<input checked="" type="checkbox"/>
Bill 14	<input checked="" type="checkbox"/>	<input checked="" type="checkbox"/>	<input checked="" type="checkbox"/>
Bill 15	<input checked="" type="checkbox"/>	<input checked="" type="checkbox"/>	<input checked="" type="checkbox"/>
Bill 16	<input checked="" type="checkbox"/>	<input checked="" type="checkbox"/>	<input checked="" type="checkbox"/>

**Payment Devices**

MDB Coin Changegiver ON

MDB Bill Reader ON

MDB Card Reader #1 ON

Executive Changegiver

**Exact Change Algorithm**

Minimum Coins in Tube

Minimum Value in Tube (x max price)

**Special Features**

Card Reader can change Price

Smart Card Status: No card inserted

Check Website for Latest Version

Read Seaga Smart Card Write Seaga Smart Card Save to File Load from File Display User Guide Exit

### Payment Devices

Check the corresponding boxes to turn Card, Coin and Bill payment on

**Executive** – check this box to operate with an Executive / Protocol-A coin changegiver.

### Coin Changegiver

Check the **Enabled** box to allow the corresponding coin to be accepted normally, and the **Enabled in Exact Change** box to allow this coin to still be accepted when the machine is in Exact Change mode.

Check the **Manual Dispense ON** box to allow tubes to be emptied manually.

### Bill Reader

Check the **Enabled** box to allow the corresponding Bill to be accepted. Check the **Use Escrow** box to hold the Bill for change and the **High Security** box to use the corresponding bill acceptance security level.

### Exact Change Algorithm

The VMC applies two criteria for creating the **Exact Change** condition. **Exact Change** is set when ANY tube has less coins in the tube than the **Minimum Coins In Tube** quantity OR if the total value of the coins in the tubes is less than the highest price set multiplied by the **Minimum Value in Tube** multiplier.

### Special Features

**Card Reader can Change Price** – check this box to allow the card reader device to apply discounts.

## SPACE to SALES PAGE

Seaga Smartware - Equipment Management Software. V2.1.0

Configuration Prices International Payment Display Messages Refrigeration **Space-to-Sales** Advanced Timed Events

Space-to-Sales

	Column 1	Column 2	Column 3	Column 4	Column 5	Column 6	Column 7	Column 8	Column 9	Column 10
Tray A		A2		A4		A6		A8		
Tray B		B2		B4		B6		B8		
Tray C		C2		C4		C6		C8		
Tray D	D2	D3	D1	D4	D5	D6	D7	D8		
Tray E	E1	E2	E3	E4	E5	E6	E7	E8		
Tray F		F2		F4		F6		F8		
Tray G										
Tray H										

Hot Buttons

Active

Smart Card Status: No card inserted

Check Website for Latest Version

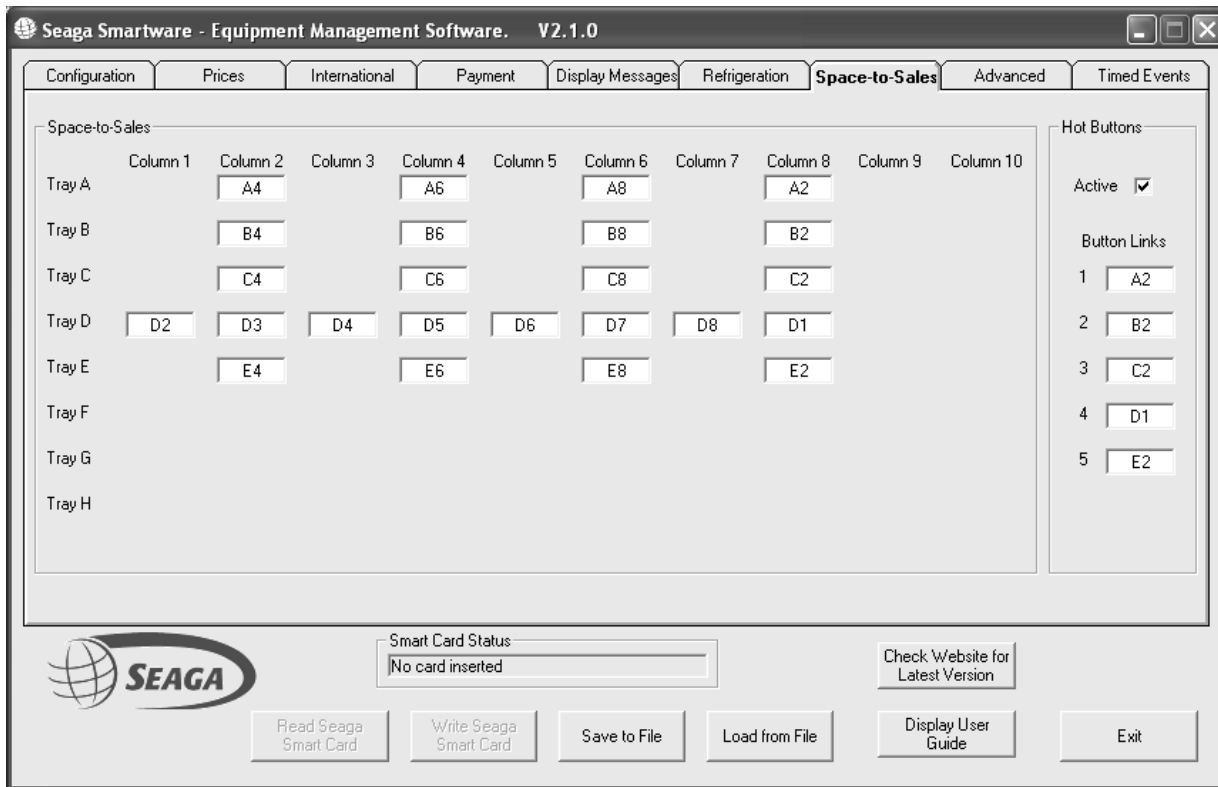
Read Seaga Smart Card Write Seaga Smart Card Save to File Load from File Display User Guide Exit

### Stock Links

Where more than one selection contains the same product it is possible to link these selections together so that if one selection is sold out the product can be dispensed from another selection. This is particularly useful for increasing the effective stock for Meal Deals, and for Can/Bottles operation.

In the example above selections D1, D2 and D3 have the same type of product and have been linked together in a chain. All other selections are not linked and refer back to themselves.

## HOT BUTTONS (Space to Sales Page)



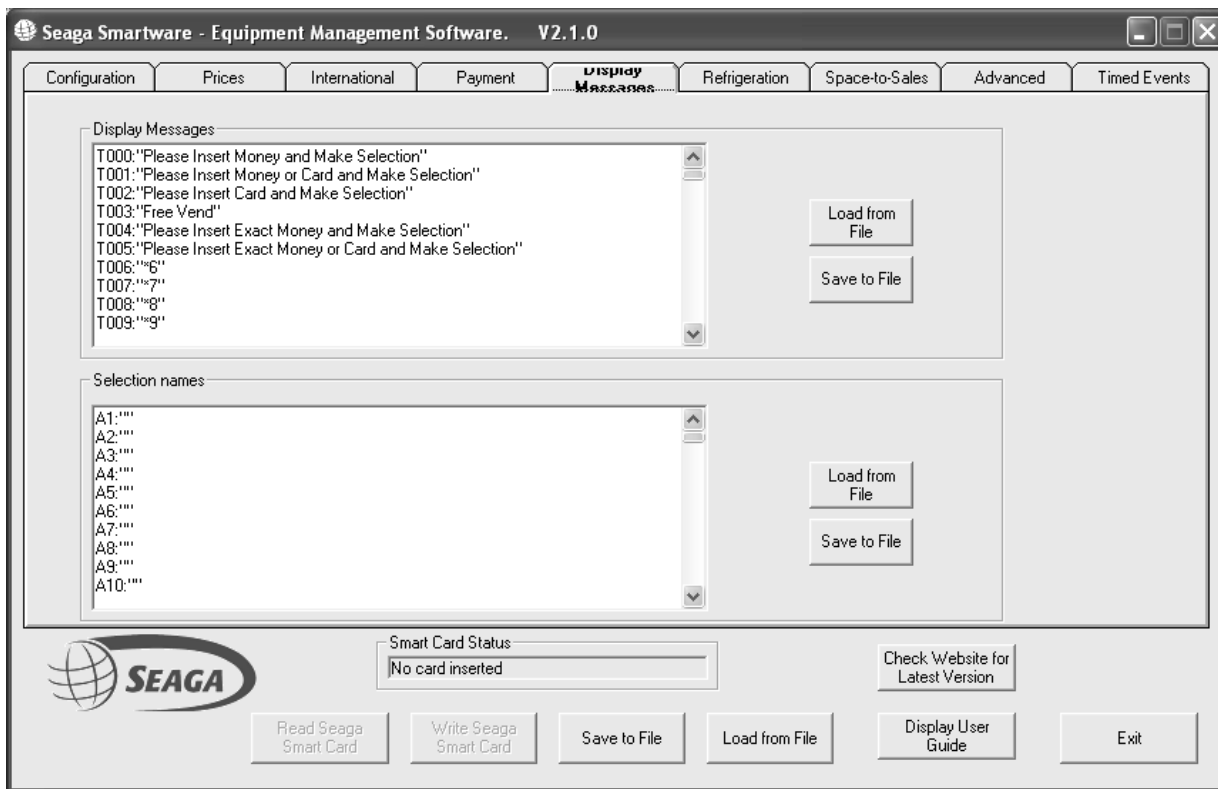
### Hot Buttons

Check the “Active Button” to use Hot Buttons.

**Hot Buttons** replace the standard keypad selections with up to 5 direct, single button selections. For capacity the Space To sales links allow multiple internal spirals to stock the same product.

In the above example Hot Button 1 selects effectively Tray A. The hot button is linked to Selection A2 which in turn is linked in a chain to the other selections in Tray A. Similarly hot buttons 2 – 5 access trays B to E respectively.

## TEXT MESSAGES PAGE



### VMC Text Messages

This window displays the text held in EEPROM for an alternate language set. To Edit the **VMC Text Messages** use the **Save to File** button to save the text to a particular file . This file can be edited using **Notepad** and then reloaded using the **Load from File** button.

### Selection Names

This window displays the text that is displayed for each **Selection** or **Meal Deal**. To Edit the **Selection Names** use the **Save to File** button to save the text to a particular file . This file can be edited using **Notepad** and then reloaded using the **Load from File** button.

When either of the "Save to File" options are selected Windows Notepad is launched directly to allow easy editing. **IMPORTANT:** When editing is complete save the changes from within Notepad and then use the **Load from File** button to install the changes.

## ADVANCED PAGE

Tray	Columns	Type	Timeout	Sold Out SW	Positive Vend Sensor
Tray A	4	Cycle Switch	5	<input type="checkbox"/>	<input checked="" type="checkbox"/>
Tray B	4	Cycle Switch	5	<input type="checkbox"/>	<input checked="" type="checkbox"/>
Tray C	4	Cycle Switch	5	<input type="checkbox"/>	<input checked="" type="checkbox"/>
Tray D	8	Cycle Switch	5	<input type="checkbox"/>	<input checked="" type="checkbox"/>
Tray E	4	Cycle Switch	5	<input type="checkbox"/>	<input checked="" type="checkbox"/>
Tray F	N/A				
Tray G	N/A				
Tray H	N/A				

### Build Configuration

This section allows the tray options to be defined for the particular machine. Select the number of **columns** for a particular tray, the Motor **Type** as below, the overall run **Timeout** in seconds for the motor and whether a **Sold Out switch** is fitted.

#### Motor Types :

- |              |  |
|--------------|--|
| Cycle Switch | - stops when the Home Switch is reached                    |
| PV Sensor    | - stops when a product triggers the "Positive Vend Sensor" |
| Timed        | - runs for a fixed period of time                          |

#### Positive Vend Sensor

- check this box if one is fitted and to be used for the corresponding tray. (Please note that some older VMC software versions may not support individual use of the Positive Vend Sensor)

### Timings

**Selection Timeout** is the number of seconds for which a selection is deemed made, and for which the **product name** and **price** are displayed.

**Motor Nudge Time** is the amount of time the motor is run after it has "homed" when **the Positive Vend Sensor** has not been triggered

### Configuration

- |                             |   |
|-----------------------------|---|
| <b>Motor Nudges</b>         | - define the maximum number of nudges (up to 6) to be used                  |
| <b>Diagnostics Passcode</b> | - a 4 digit code for access to additional diagnostic features in the menus. |
| <b>Advanced Passcode</b>    | - a 4 digit code for access to the Advanced menu features.                  |

### Make Logging Smart Card / Make Audit Smart Card

- create a blank smart card of the selected type.

## REFRIGERATION PAGE

Seaga Smartware - Equipment Management Software. V2.1.0

Configuration Prices International Payment Display Messages **Refrigeration** Space-to-Sales Advanced Timed Events

Refrigeration

Zone 1 ON Low Limit 32.0 F High Limit 32.0 F

Zone 2 ON Low Limit 32.0 F High Limit 40 F

Auto Defrost ON Defrost Duration 10 mins First Defrost Time 00:00 Interval (Hours) 03

Health & Safety Mode ON

Smart Card Status: No card inserted

Check Website for Latest Version

Read Seaga Smart Card Write Seaga Smart Card Save to File Load from File Display User Guide Exit

**Zone n ON** – check the appropriate boxes turn refrigeration control ON for the Zone

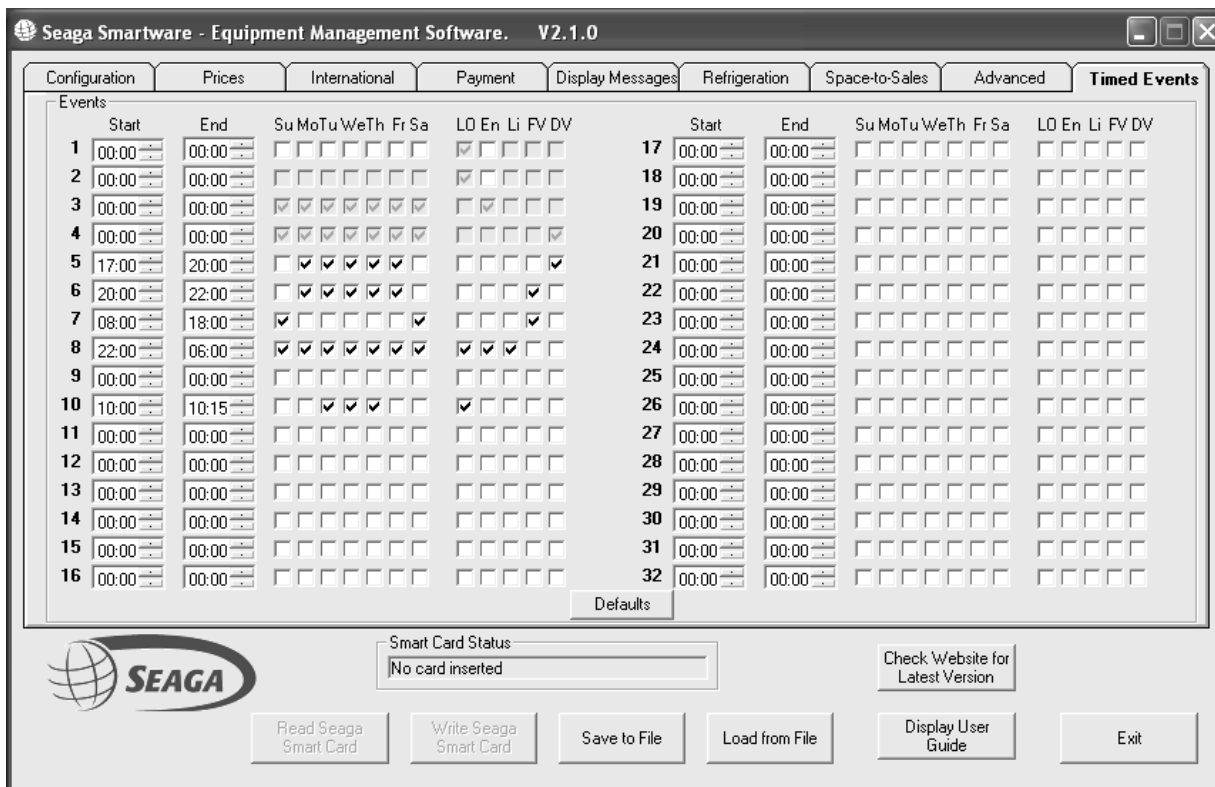
**Low Limit / High Limit** Temperatures – set the upper and lower temperature limits for the zone. Note: the VMC internally works in 0.5C steps so exact Fahrenheit figures may be adjusted to the nearest 0.5C step.

### **Auto Defrost**

Check the box to turn automatic defrosting ON. The defrost cycle is run for **Defrost Duration** minutes every **Interval** hours. The **First Defrost** after turning the feature ON may be set with the pull-down option. Thereafter the **Interval** value defines when the next defrost will occur.

**Health & Safety Mode ON** – check the box to turn this lockout mode ON.

## TIMED EVENTS PAGE



Version 1.10 and later Premier VMC software supports up to 32 separate timed events. Each event can be set to occur between the **START** and **END** times for the selected **days of the week**. Event times may overlap.

Each Event can then have the following actions (more than one selection may be applied)

- LO** Timed Lockout
- En** Refrigration Energy Saving
- Li** Lights OFF
- FV** Free Vend
- DV** Discounted Vend (If both **DV** and **FV** are selected, free vend will apply)

Use the **Defaults** button to clear the events back to the factory default configuration

Events 1 – 4 are backwards compatible with earlier versions of VMC software.

- Events 1 and 2** Timed Lockouts with shared **Days of the Week** active.
- Event 3** Energy Saving only
- Event 4** Discounted Vend only

In the screenshot above the following events are set for an example “factory/office” application:

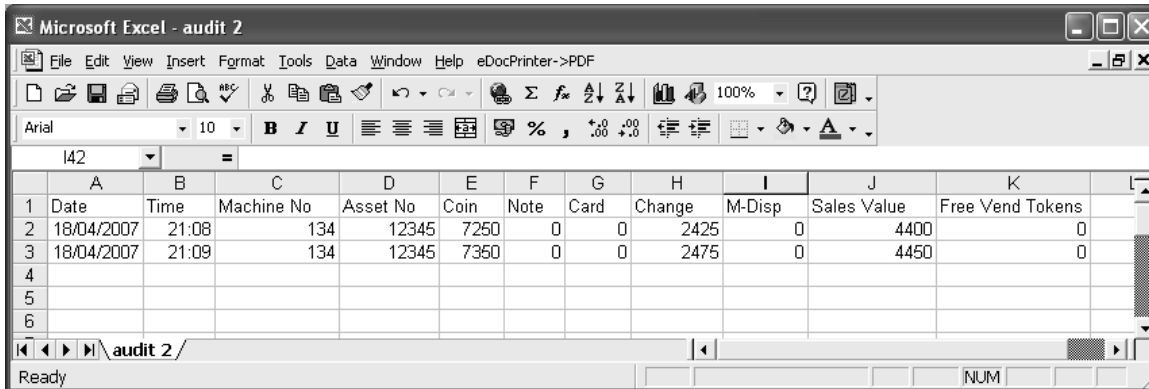
- Discounted prices for anyone working late 17:00 to 20:00 on weekdays
- Free vend for anyone working after 20:00 on weekdays and between 08:00 and 18:00 at weekends.
- Energy saving every night from 22:00 until 06:00 the next morning.
- Timed Lockout between 10:00 and 10:15 on Tuesdays, Wednesdays and Thursdays for a “staff meeting”  
!



## Appendix 1 – File formats

Both Audit and Temperature Logging Cards are saved to .csv (comma separated value) format files that can be imported into a number of packages, including Microsoft Excel. Records are tabulated with a title to each column.

**Example Audit File** – values are in base units (cents, pence etc.)



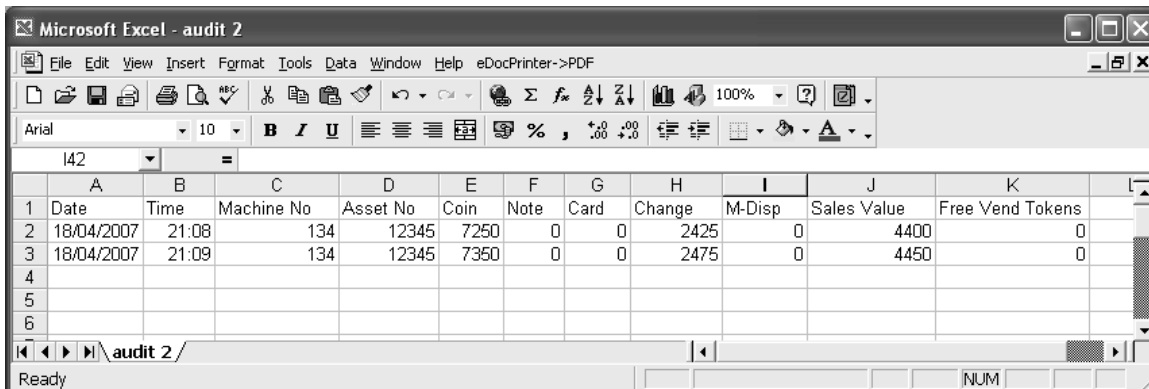
	A	B	C	D	E	F	G	H	I	J	K	L
1	Date	Time	Machine No	Asset No	Coin	Note	Card	Change	M-Disp	Sales Value	Free Vend Tokens	
2	18/04/2007	21:08	134	12345	7250	0	0	2425	0	4400	0	
3	18/04/2007	21:09	134	12345	7350	0	0	2475	0	4450	0	
4												
5												
6												

**Example Temperature Logging File** – temperatures are in Centigrade, defrost duration is in minutes. Readings are logged approximately every minute.

## Appendix 1 – File formats

Both Audit and Temperature Logging Cards are saved to .csv (comma separated value) format files that can be imported into a number of packages, including Microsoft Excel. Records are tabulated with a title to each column.

**Example Audit File** – values are in base units (cents, pence etc.)



	A	B	C	D	E	F	G	H	I	J	K	L
1	Date	Time	Machine No	Asset No	Coin	Note	Card	Change	M-Disp	Sales Value	Free Vend Tokens	
2	18/04/2007	21:08	134	12345	7250	0	0	2425	0	4400	0	
3	18/04/2007	21:09	134	12345	7350	0	0	2475	0	4450	0	
4												
5												
6												

**Example Temperature Logging File** – in this example, temperatures are in Centigrade, defrost duration is in minutes. Readings are logged approximately every minute.

Microsoft Excel - log8

File Edit View Insert Format Tools Data Window Help eDocPrinter->PDF

100%

Arial 10 B I U

F25 =

	A	B	C	D	E	F
1	Date	Time	Zone 1	Zone 2	Defrost	
2						
3	18/04/2007	23:55	24.5	26.5		
4			-18.5	-4		
5			4.5	12.5		
6			12	19		
7			16	21.5		
8	19/04/2007	00:00			10	
9			19.5	23.5		
10			21	24.5		
11			22	25.5		
12			22.5	26		
13			23	26		
14			23.5	26.5		
15			23.5	26.5		
16			23.5	26.5		
17			23.5	26		
18			23.5	26		
19			24	26.5		
20			23.5	26.5		
21			24	27		
22			24	27		
23			24	27.5		
24			24.5	27.5		
25			24.5	28		

Ready NUM

## SECTION 5

## DELIVERY OF PRODUCT

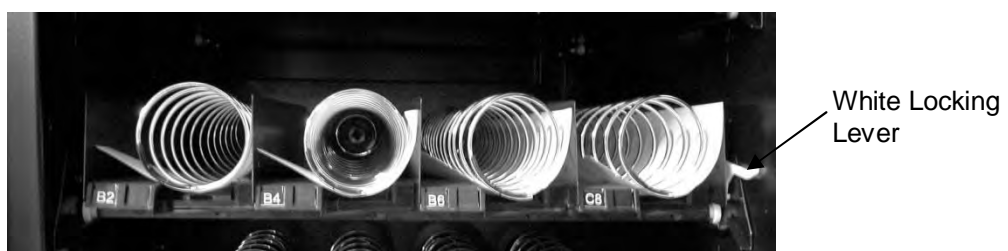
### DELIVERY SYSTEM

Your vendor consists of the Keypad, 2 Line VF Display, Driver Motors, Product Trays, Helix Coils and Delivery Bin. In the case of the refrigerated models vending beverages, product stabilizers are also included. The customer inserts money and enters their selection on the Keypad. The selection's Driver Motor turns the Helix Coil that vends the product into the Delivery Bin.

### PRODUCT TRAYS

The SP Series features lock and release product trays. On the right side of each product tray you will find a Locking Lever (Fig. 15). To pull out the Product Tray push down on the Locking Lever and roll toward you to tilt position. Or completely push the locking lever to the back.

Fig. 15



## **VIGILANT VEND SENSOR SYSTEM**

The Vigilant system is a series of infrared sensors that send a beam of light across the delivery bin. If this beam is broken by a product, the Premium machine knows that an item was delivered to the customer. If this beam is not broken, the Premium machine assumes that nothing was vended and turns the selection spirals by ¼ turns until a product delivery is sensed. If, after the coils have turned a full revolution back to home without delivering a product, the customer will be asked to make another selection or to press the Coin Return button to receive their money back.

Certain products can be problematic for any vend sensing system. Products that are very thin or very small in size may, on occasion, miss the beams. With proper loading of the machine, sensing systems are irrelevant. A comfort level is provided to customers who walk up to the machine and know, through technology, they will not experience a “rip-off”. For this reason, a vend sensor system is desirable – however, if you vend very small or very thin items, you may want to consider turning off your sensing system in case of malfunction via product size. See the Service Mode section of this manual, Diagnostics sub-menu, for instructions.

The Vigilant sensors are located inside the delivery bin as shown in Figure 14 below. There is a red indicator light located on the left side when viewing the bin from the inside with the door open. This light should be lit when the system is on, indicating that there is power to the system. Blocking any of the beams turns off the red indicator light, which means the system is working correctly.

Note: When performing Test Motors without product loaded, it is a good idea to shut off the Vigilant system.

## **SECTION 6**

## **TROUBLE SHOOTING**

1. **NO DISPLAY ON THE FRONT PANEL**

- a. Transformer fuse blown
- b. Display board defective
- c. System control board defective
- d. Faulty display harness
- e. Harness may be unplugged
- f. Restart machine

2. **SELECTION WILL NOT VEND**

- a. Vend mechanism binding on tray
- b. Product jammed
- c. Tray or Motor connection unplugged or faulty connection
- d. Bad motor or defective motor
- e. System control board defective
- f. Detection system may be blocked, if enabled

3. **MULTIPLE VENDS FROM ONE SELCTION**

- a. System control board defective
- b. Defective motor switch
- c. Detection system malfunction, if enabled

4.

**MULTIPLE VENDS MORE THAN ONE SELECTION SIMULTANEOUSLY**

- a. Defective motor
- b. Motor harness not plugged into the vend motor correctly
- c. Defective or damaged motor interface board [KS11]
- d. Tray cable faulty
- e. System control board defective

5.

**UNIT WILL NOT ACCEPT MONEY**

- a. All Prices are set to zero or machine is set to Free Vend
- b. Will not accept bill if coins in coin changer below the minimum level
- c. Will not accept more than one bill if the bill equal or exceeds the highest priced item.
- d. No power to system control board
- e. Coin Mechanism or Bill acceptor defective.

A: These buttons are disabled in the normal operating mode to protect from unauthorized use. To enable the buttons enter the service mode, scroll to the settings submenu, press F to enter then scroll to Coin Refill and press F. The button will now be enabled. To exit press the G button multiple times.

**Q: I rearranged my trays and now some selections don't work. Display says Make Alternate Selection.**

A: Enter the service mode. Press the 10 button 4 times. Display should show Passcode Accepted. Scroll to Advanced sub menu and press F to enter. Scroll to Rows / columns setting and press F to enter. Display will show setting for each tray position. The 1 button will cycle through the different tray configurations. It will cycle from 0 (tray off) then to 4, 5, 7, 8, 10 then back to 0. Set this to the number of selections on that tray. When finished with the settings for that tray use the arrow keys to scroll to the next one to set. If you are finished press the G key multiple times to exit. This only applies to machines with software revision .65 and higher. Earlier versions will require a software update. Contact your distributor or sales person for update information.

**Q: My machine will not take in bills but accepts change ok.**

A: Several options here but the most common especially when first setting up the machine is that there is not enough change in the changer. By looking at the display it will give you a clue as to what may be wrong. If the display reads "Please Insert Exact Money...." that indicates there is not enough change in the changer. Fill the coin tubes completely full. Completely full means you can't get any more change into the coin tube. Press the coin return button and the display should show Canceling. The display should now show "Please Insert Money....." without the word Exact.

**Q: My machine still will not accept bills and the display does not indicate Exact change.**

A: If the validator takes in the bill a ways but spits it back out, that indicates that the bill may be unacceptable or the validator needs cleaning. Follow the validator manufacturer's recommendation for cleaning.

**Q: My machine will accept \$1 bills ok but not \$5 bills.**

A: This situation can depend on several factors. The amount of change being reported in the changer and the highest vending price in the machine. Make sure the changer is full of change. If you are vending high dollar items you may need to replace the changer with a larger capacity model and/or one that utilizes dollar coins if the changer is constantly low on change.

**Q: My machine will not accept the new \$5 bills.**

A: Contact the bill validator manufacturer for upgrade instructions. Not accepting currency that has been changed due to a Federal Government mandate is not covered under our manufacturer's warranty.

**Q: My machine will vend a product, display Vend Error then give my money back or allow me take make an alternate selection.**

A: This indicates there is a problem detected with the vend motor. Each vend motor has a small micro switch inside that indicates when the motor has made one full revolution and returns back to what is referred to as the "home position". If this signal is not received back to the controller in a specified amount of time the controller will indicate and error and refund the money. The problem could be in an individual motor itself, the tray wire harness or any connection in between the tray to the control board. If the whole tray acts this way that usually indicates that the tray harness or any connection in between to the controller may be bad. The easiest way to troubleshoot this situation would be to swap tray connections where the tray harness plug plugs into the machine. For example if the problem appears on the A tray, unplug the A tray and the B tray (assuming they both have the same number of selections), swap the connections and plug the A tray into the B tray receptacle and vice versa. Now do your test vending by selecting the B selections on the keypad and the A tray should operate. If the problem follows the tray then suspect either the motor or the tray cable harness. If the problem stays with the A receptacle and now the B tray exhibits the problem then the problem is in a connection somewhere between the A receptacle and the controller board. Make sure to examine any and all connections for any loose wires, etc.

**Q: My display is dead or intermittent but the rest of the machine appears to be working.**

A: Check the gray flat ribbon cable connection between the display and the controller board to insure the plugs are plugged in securely.

**Q: My machine will not cool.**

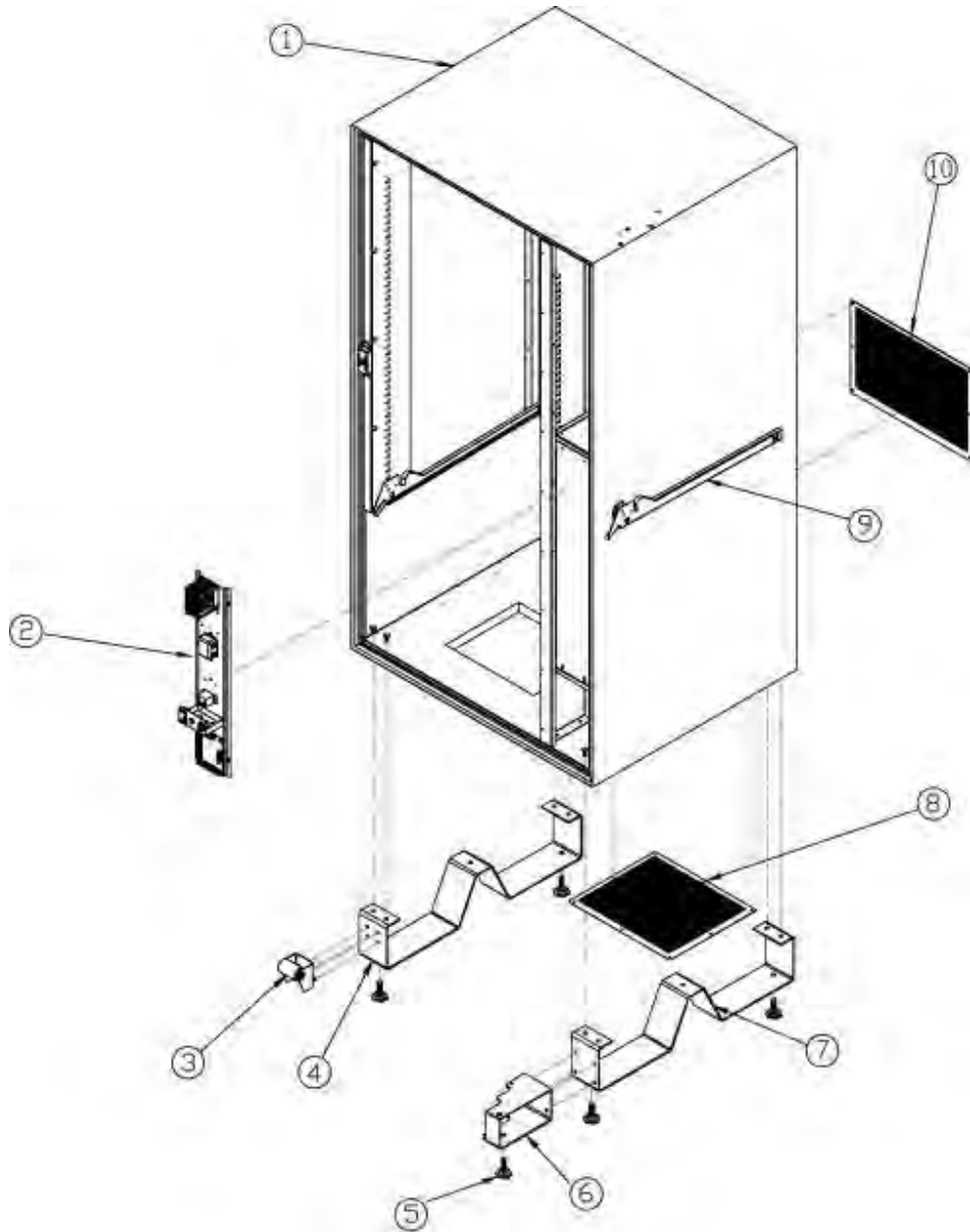
A: Several things to check here.

1. Make sure the machine programming is set up properly so that Zone 2 is enabled and the proper temperature limits are set for Zone 2. Zone 2 lower should be set around 37 degrees and Zone 2 upper should be around 5-6 degrees warmer. If the temperature is set too cold then you risk the chance of evaporator freeze over.
2. On models equipped with a refrigeration fuse make sure it is not blown. The fuse needs to be a 20 amp Slo-Blo fuse. Nothing less. An easy way to test the fuse is to press on the lower door switch to see if the 3 evaporator fans run that are located below the bottom tray.
3. Inspect the evaporator coil to see if it may be frozen over. Using a flashlight shine it into the 3 evaporator fans located under the bottom tray. You are looking for aluminum fins behind the fan motors. If they are completely white or solid with ice this will keep the air from flowing properly and cause the machine to not cool. To thaw out remove the 3 prong condensing unit plug, not the evaporator fan plug and just close the door and let set for overnight to insure it completely defrosts. Be prepared in case the defrost water pan overflows on the floor. You may need to set some towels around and under the machine to catch any overflow. After the machine is thawed completely out you will want to check the temperature settings to insure they are not set too cold. You may also enter the Advanced menu and check the defrost settings. The standard defrost settings are for a duration (DUR) of 25 minutes and interval (INT) of 3 hours. This can be changed if need be. Press the lower door switch to insure all 3 evaporator fans run. Also close the door and listen to hear if the fans start when you close the door. If they don't this will also cause a freeze over. You may need to adjust the door switch to facilitate proper operation.
4. Check the upper door switch. The easiest test is to close the door then while opening the door watch the display to see if you see the message Sales Value \$xxxx.xx in the display. If you do not then suspect the upper door switch may need adjustment. You can reach over the door and press it manually while watching the display to see if it works.
5. As a manual test of the cooling system you can enter the Diagnostics section of the menu and select the Relays test function. Select Relay 02, press F and the cooling system should turn on momentarily.
6. Another manual test you can try on models equipped with a standard 3 prong receptacle for the cooling assembly is unplug the cooling assembly plug from the refrigeration control panel and plug that cord into a standard 3 prong extension cord. The cooling system should run.

**CAUTIONS:**

1. High voltage is located in the area of the unit and could cause injury or death.
2. Replacement of the bill acceptor, coin changer, front panel display, system control board or vend motors should only be performed by trained personnel.

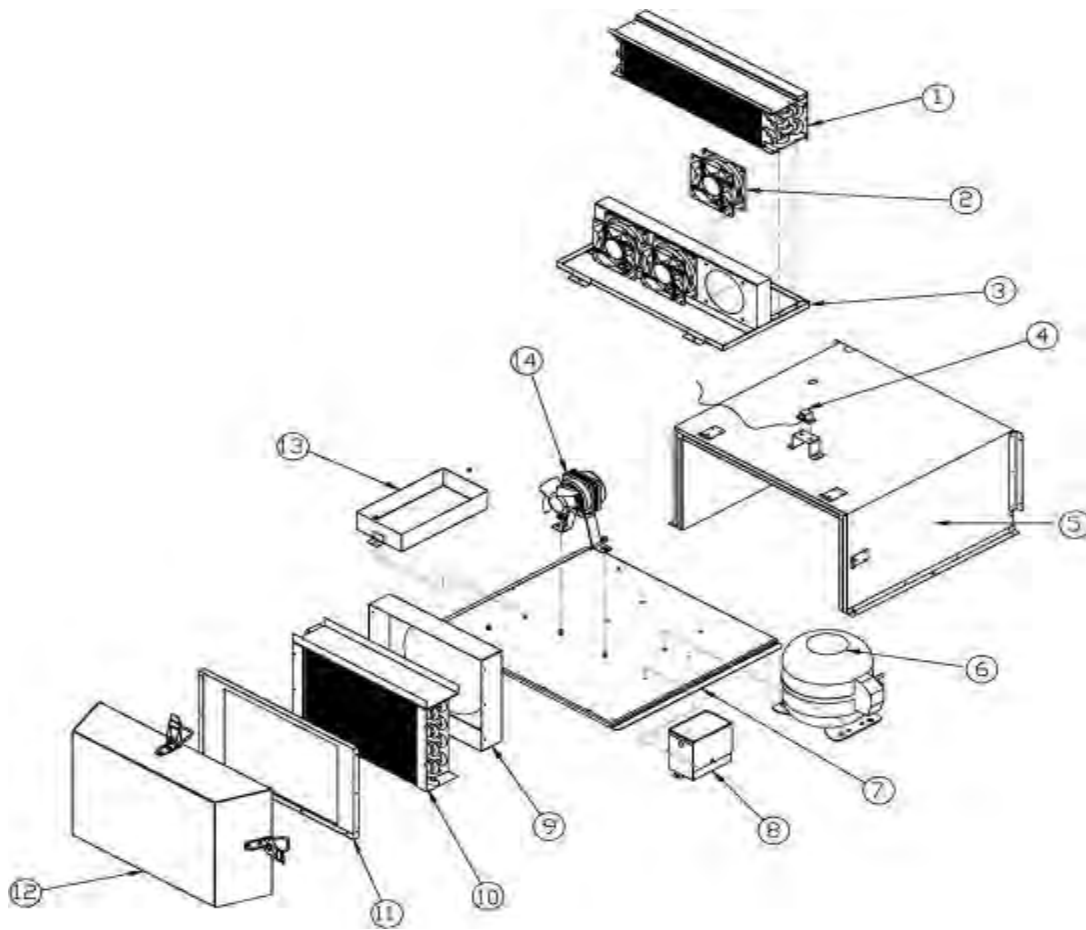
## Cabinet Assembly



### Cabinet Assembly, Parts List

ITEM	PART NO.	DESCRIPTION
1	8428001	CABINET
2	8428008	ELECTRICAL PANEL ASSEMBLY
3	8428003	DOOR SUPPORT ASSEMBLY
4	7011014	LEG (LEFT)
5	7021032A	LEVELLING SCREW
6	8411002	LEG EXTENSION
7	7011006	LEG (RIGHT)
8	8428004	GRILL (CABINET BOTTOM)
9	8628003	PRODUCT TRAY RAIL (RIGHT)
10	8428005	GRILL (CABINET REAR)

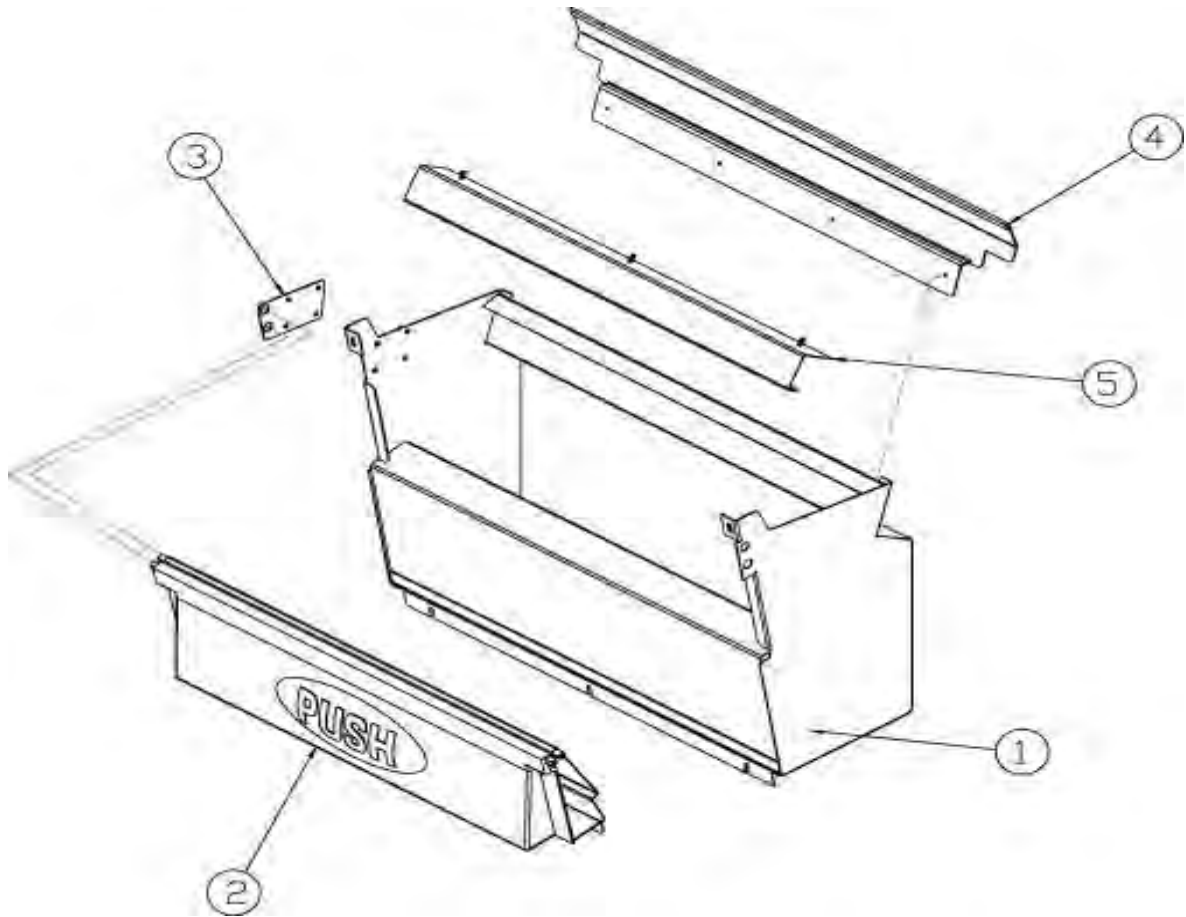
## Refrigeration Deck Assembly



### Refrigeration Deck Parts List

ITEM	PART NO.	DESCRIPTION
1	6717013	EVAPORATOR
2	6418003	MUFFIN FAN
3	8428015	EVAPORATOR ASSEMBLY
4	8418005	TEMPERATURE SENSOR
5	8428016	REFRIGERATION DECK COVER ASSEMBLY
6	8417003	COMPRESSOR
7	8411024	REFRIFERATION DECK TRAY
8	8428017	CAPACITOR BOX ASSEMBLY
9	8411025	CONDENSER FAN HOUSING
10	7017004	CONDENSER
11	8411026	CONDENSER BRACKET
12	8428017	REFRIGERATION DECK FRONT HOUSING
13	8411028	CONDENSATE PAN
14	8418001	CONDENSER FAN

## Product Bin Assembly

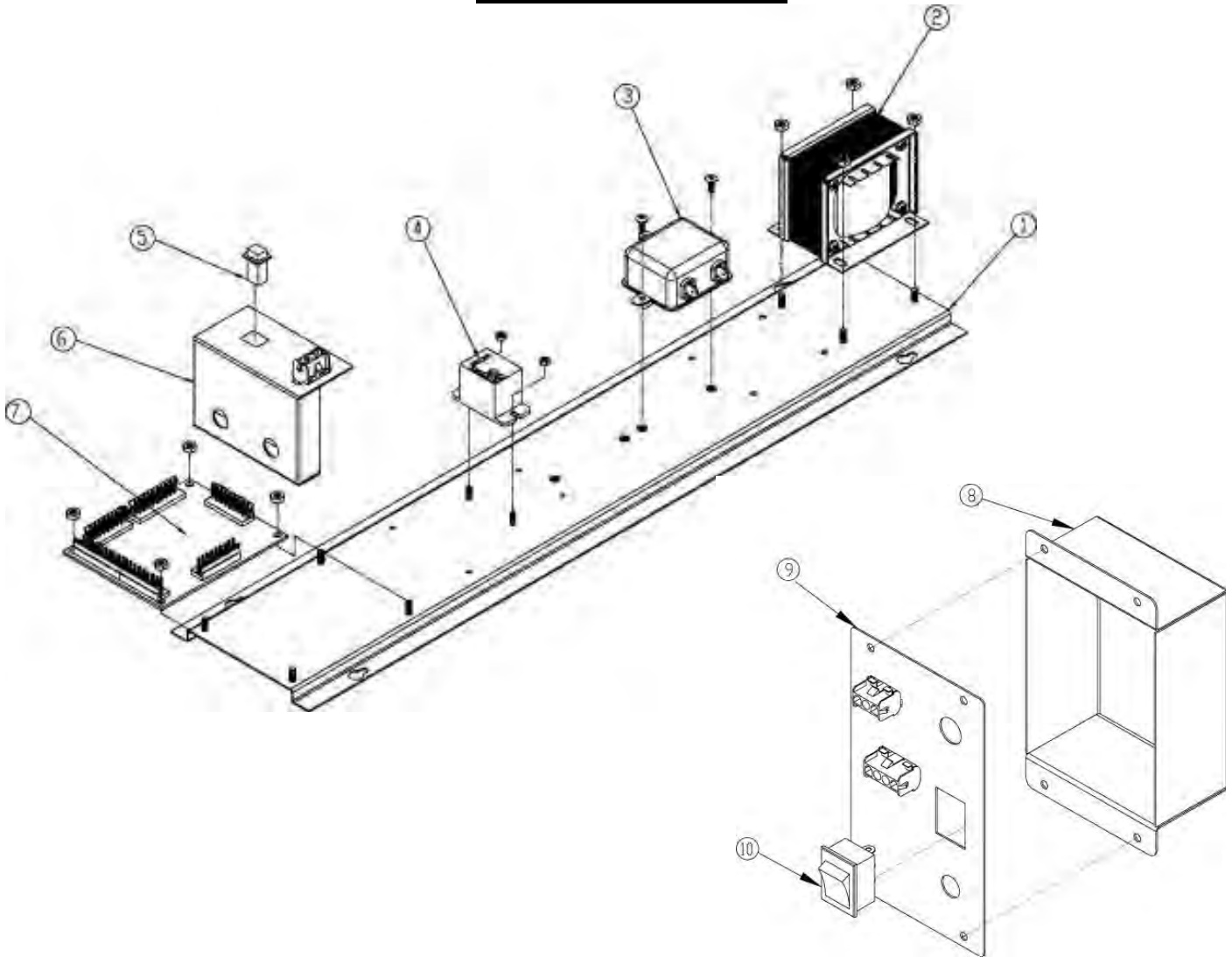


### Product Bin Assembly, Parts List

ITEM	PART NO.	DESCRIPTION
1	7028014	PRODUCT BIN
2	7014014	PUSH DOOR ASSEMBLY
3	8611007	CAM PLATE
4	7011032	PRODUCT GUIDE BRACKET
5	7011033	ANTI THEFT BRACKET



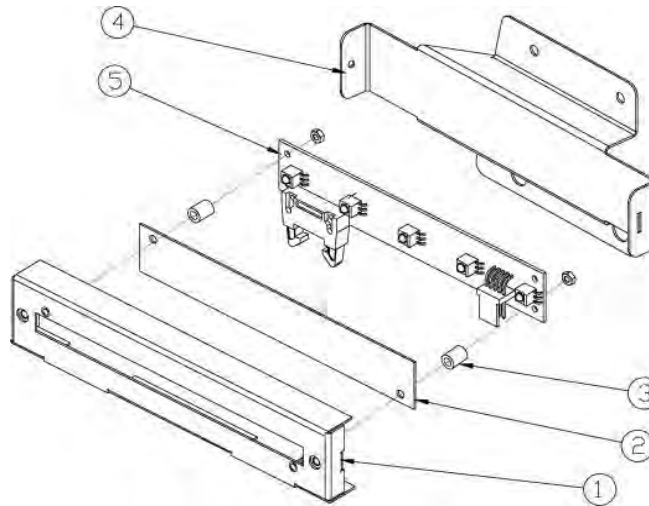
## Electrical Panel Assembly



### Electrical Panel Assembly, Parts List

ITEM	PART NO.	DESCRIPTION
1	8411017	ELECTRIC PANEL
2	8418003	TRANSFORMER (110V/220V, 1.5A)
3	7018012	FILTER
4	7018039	RELAY (24V DC)
5	7018032	CIRCUIT BREAKER
6	8411018	SWITCH BRACKET (ELECTRICAL PANEL)
7	8418006	AUXILARY BOARD
8	8411019	POWER BOX
9	8411020	FRONT PLATE ELECTRICAL BOX
10	7018016	ON/OFF SWITCH (16A, 250V)

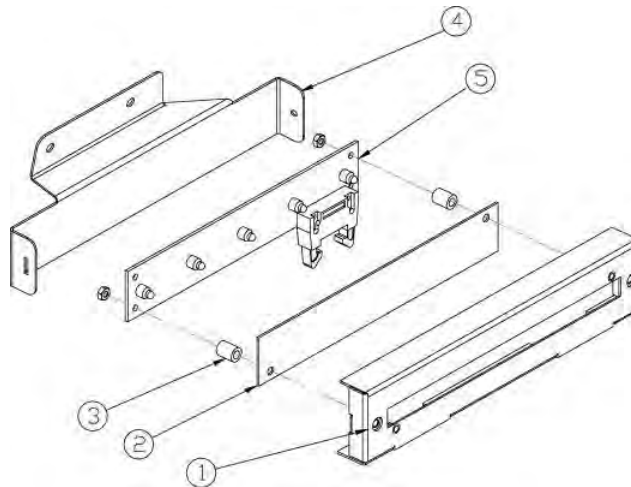
**Vigilant Vend Sensor, Right Side Assembly**



**Vigilant Vend Sensor, Right Side Parts List**

ITEM	PART NO.	DESCRIPTION
1	7011040	SENSOR BRACKET (RIGHT SIDE)
2	7014024	SENSOR SHEET
3	6014015	SPACER
4	7011041	SENSOR BRACKET (RIGHT SIDE)
5	8618009	VEND SENSOR - DETECTOR

**Vigilant Vend Sensor, Left Side Assembly**



**Vigilant Vend Sensor, Left Side Parts List**

ITEM	PART NO.	DESCRIPTION
1	7011042	SENSOR BRACKET (LEFT SIDE)
2	7014024	SENSOR SHEET
3	6014015	SPACER
4	7011043	SENSOR BRACKET (LEFT SIDE)
5	8618010	VEND SENSOR - EMITTER