



VALCHANGER OPERATIONS MANUAL SERIES AC1000/1001

Table of Contents

SECT. A: SET-UP & INSTALLATION

Uncrating & Setup _____	3
Mounting instructions _____	3-4
Filling the Hopper _____	4
Using the Dump Mode _____	4
DIP Switches _____	4-5
Fuses _____	5
Functional Descriptions _____	5-6
Indicator Lights _____	6
Wiring definitions _____	6
Coin Control Hopper (Filling) _____	7
HOPPER ERROR CODES _____	7

SECTION B: VALIDATOR INFO

Setting 18-Pin Jumper Plug _____	8
CoinCo Validator information _____	9-15
Mars 2600 information _____	16-21

SECTION C: COIN HOPPER INFO

Un-Jamming the Hopper _____	24-26
-----------------------------	-------

SECTION D: TROUBLESHOOTING INFORMATION

Troubleshooting Guide _____	28
Technical Flow Diagram _____	29-30

SECTION E: PARTS LISTS

Cabinet Parts Breakdown _____	31
Parts Coin Control Hopper MKIV _____	33
Parts CoinCo Bill Validator _____	34-37
Parts Mars Bill Validator _____	38-40

SECTION F: SERVICE CENTERS

Mars (MEI) _____	41-43
CoinCo _____	44

Rev. MONO A-40 Jan.'04

Specifications

Operating voltage	120 VAC +10/-15 %
Power consumpt.(controller only, add hopper and validator)	10w
Operating temperature	32 - 130 degrees Fahrenheit
Interface to Hoppers	24vdc & 12vdc 1.5 amps max.
Interface to Validators	120vac .5 amps max.

Warranty

CoinCo MAGPRO 00 B & MARS AE2601 Validator is warranted for two years from date of purchase.

COVERED

¥ Defect in workmanship or material.

NOT COVERED

¥ Damage caused by physical abuse.

¥ Misapplication

¥ Vandalism

¥ End users attempt, on his own to repair item

¥ Cleaning maintenance

It is the End User's responsibility to follow cleaning maintenance procedure outline on page(s) 14/20.

Any unit coming in for repair requiring only a cleaning will be charged a flat rate of \$65.00 plus shipping and handling.

Dispensing System and Logic Board

The dispenser and logic board is warranted for one year from date of purchase.

COVERED

¥ Defects caused by material or workmanship.

NOT COVERED

¥ Damage caused by physical abuse.

¥ Misapplication

¥ Vandalism

¥ End Users attempt, on his own to repair.

A Return material authorization number (RMA #) must be obtained before returning a unit for repair. A copy of invoices must accompany any and all warrantee work

UNCRATING AND SET-UP

Remove your Series 1000 changer from the shipping box. Open the door. (*The T-handle is a screw-in type and therefore, must be turned at least 10 times counter-clockwise until it opens.*) Inspect for any connectors or components that may have been dislodged during shipping. The lock and keys for your changer will be inside the manila envelope along with this manual. To install the lock, insert the cylinder into the round hole in the middle of the T-handle and push until it stops. Now turn the key and lock until you hear it "snap." Turn the key counter-clockwise ¼ turn and remove the keys.

NOTE: The only way to get a duplicate set of keys made is to save the red tag that comes between the keys. This ID # starts with "ACC ####".

TEST:

Before permanently installing the changer, do a functional test to verify that there is no shipping damage to your new changer(s).

Extend the power cord through the hole in the back of the changer or the bottom and plug it into a **grounded 120vac outlet**. **The dip switches are already set for a 4 coin per dollar pay-out of the hopper, and the Bill validator is ready to accept \$1-\$5-\$10-\$20 dollar bills.**

Fill the hopper with at least 100 coins. On the main logic board turn the switch on the bottom right corner "ON". (SEE FIG. 1 ON PG.3) *The rocker switch has a "1" and "0" printed on it. When the "1" is pressed down the changer is "ON".*

MOUNTING THE AC1001 TO A WALL

IF YOU ARE UNSURE IN ANY WAY IN PROCEEDING WITH THE FOLLOWING STEPS, PLEASE HIRE A LOCAL PROFESSIONAL ELECTRICIAN TO MOUNT YOUR CHANGER FOR YOU!

1. Disconnect any and all AC power going to the series 1001 changer. (See fig. 1)
 - A. Unplug the AC line cord from the bottom of the board.
 - B. Unplug the validator connectors on the right side of the board.
 - C. Unplug the hopper harness connector on the left side of the board.
 - D. Unbolt the ground wire from the right side of the cabinet.
 - E. Remove the main logic board and hopper from the inside of the changer.
 - F. Put the nuts back on the studs to avoid losing the brass spacers on the studs.
2. Slide the hopper out of the cabinet.
3. Note: You will need to verify with the building code to see if it is allowable to plug the changer into a 3 prong grounded outlet. If it is not, there must be 120VAC run through conduit to the changer. If it is not required, proceed to step #6.
4. Let the electrician run the conduit, install the new breaker, wire and help decide how the wiring will enter

the changer (from the back or the bottom). This will affect the mounting location.

5. After the conduit has been installed, proceed with the mounting.
6. Locate the 4 punch-outs on the back wall of the changer. Using a screwdriver and hammer knock the punch-outs out by hitting them from the inside of the changer.
7. Using a stud locator, find a location to hang the changer by locating the wall studs.
8. Find an appropriate wall to bolt the changer into. The wall should have studs or be constructed of concrete. Consult a professional with any questions you may have.
9. **NOTE: HANGING THE CHANGER FROM LESS THAN ALL 4 HOLES MAY BE DANGEROUS. EACH HOLE NEEDS A BOLT THROUGH EACH ONE MOUNTED SECURELY TO THE WALL. MOUNTING THE CHANGER IN ANY OTHER WAY MAY RESULT IN THE CHANGER BEING TORN OFF OR FALLING OFF THE WALL RESULTING IN PERSONAL OR CUSTOMER INJURY ALONG WITH ELECTRICAL SHOCK.**
10. Choose a height to mount the changer keeping in mind that a handicapped person in a wheelchair should still be able to insert a bill into the bill validator. (We recommend no higher than 4 feet above the ground.)
11. Have someone hold the changer against the wall while someone else marks the holes. **CAUTION: THE CHANGER WEIGHS 70 POUNDS DO NOT EXERT YOURSELF SO THAT YOU MAY CAUSE AN INJURY.**
12. **BEFORE DRILLING THE FOUR MARKED HOLES ENSURE THAT THERE ARE NO ELECTRICAL WIRES, TELEPHONE LINES, GAS, OR WATER LINES BEHIND THE WALL WHICH DISRUPTING MAY CAUSE A LOSS OF LIFE OR PERSONAL INJURY!**
13. Hold the changer back up to the wall. Thread and tighten bolts.
14. Verify that the machine is securely mounted.
15. Reinstall the main logic board.
 - A. Before installing the main logic board, verify that the plastic safety-insulating sheet is still against the back wall where the board will be mounted and that there is a 3/8" spacer on each stud.
 - B. Install the main logic board and properly tighten the nuts.
 - C. Re-bolt the ground wire into the right side of the cabinet.
 - D. Plug the validator connector into the right side of the board.
 - E. Plug the hopper harness connector into the left side of the board
16. If the changer is permanently connected through a conduit, proceed to step #18.
17. Feed the AC line cord out the bottom or the back of the changer then perform the following.
 - A. Connect the AC line cord into the bottom of the main logic board.
 - B. Plug the male end into the AC wall outlet. **Do not use an extension cord unless allowed by the building electrical code.**
 - C. **Important:** Attach the line cord clamp to the line cord. Verify it is at the right length and that the line

cord is not rubbing against any sharp edges or is being strained in any way. Then mount the line cord clamp to the studs at the hole. Tighten securely. Installation is finished and you can proceed to the "Filling the Hopper" section.

18. In order to continue you will need to purchase electrical cable conduit, a standard 3-prong AC wall outlet and 12-gauge wire. We highly recommend **HIRING** a qualified electrician to perform the following!
 - A. Install the conduit box on the conduit entering the cabinet in the lower right side of the cabinet.
 - B. Secure the 3 wires (hot, neutral, and ground) to the AC wall outlet and the ground wire should also be directly attached to the cabinet ground terminal.
 - C. Connect the AC line cord into the bottom of the main logic board.
 - D. Plug the male end into the AC outlet just installed.
 - E. Properly fold the line cord to avoid sharp corners and any other damage.
19. Proceed to the "Filling the Hopper" section.

FILLING THE HOPPER

When the hopper has less than 80 - 100 coins left in it the red "Empty" LED will light on the front of the changer. Whenever the "Empty" LED is "ON" the validator is disabled and it will no longer accept bills.

1. Turn OFF the power on the main logic board.
2. Slide the hopper out from the cabinet and insert the coins through the opening on the top. *There must be at least enough coins to cover the two gold plates at the bottom of the hopper. (Somewhere between 160 and 1600 coins minimum to maximum.)*
3. Slide the hopper back into the hopper plate. **Do not use excessive force!**
4. Turn "ON" the power switch. The "Empty" LED is now off and the bill validator is ready to accept bills.

USING THE DUMP MODE TO EMPTY THE HOPPER

1. Open the cabinet door.
2. Turn OFF the POWER switch.
3. Place a suitable container in front of the hopper to catch the coins.
4. Press and hold the "DUMP" button on the upper left corner of the Main Logic Board. Turn ON the Power switch. The red LED on the main logic board will come on then go off. Once the red LED goes off, release the "DUMP" button. If it is not released within two seconds, the "DUMP" mode is canceled as a security feature. The hopper will dispense coins until the POWER switch is turned OFF. If the Red LED on the Main Logic Board is not flashing 3-5 times per second the dump mode was not accessed. Please try again.

THE DIP SWITCHES

The 1000/1001 series changer is capable of dispensing from 0 to 31 coins per dollar. Setting the coins out per dollar is controlled by which Dipswitches turned "ON." (Refer to figure 1 for their location.) For example, switch #3 is "ON"; therefor the pay out equals 4 coins per dollar.

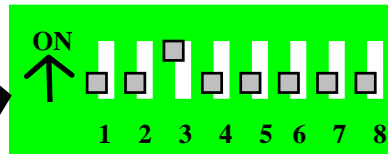
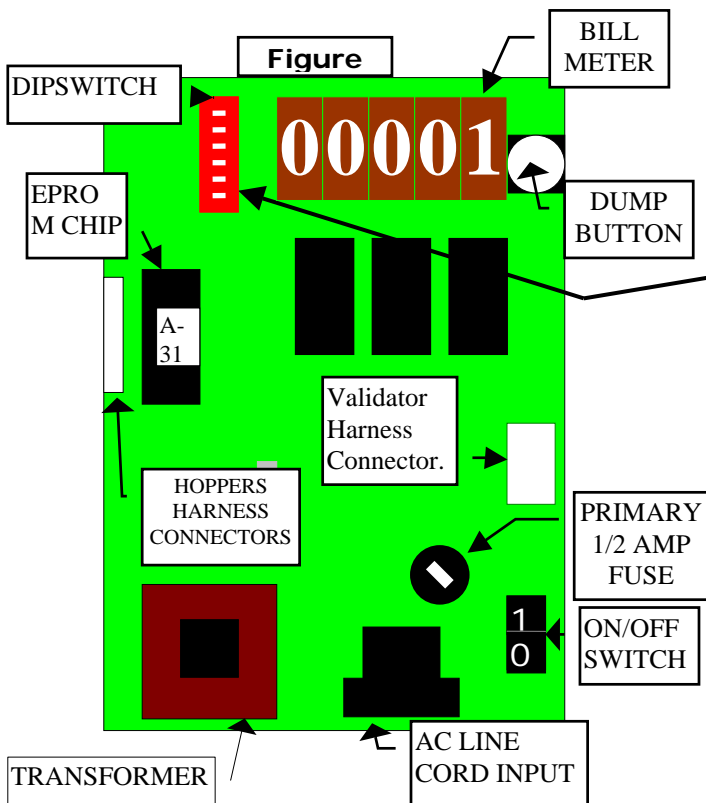

FIGURE 2
(THIS IS NOT THE DipSwitch BANK FOR SETTING THE BILL DENOMINATIONS.
(For those dip switches go to page 10.)

The following table shows how to set the dip switches to your desired pay out.

"ON"	COINS PER DOLLAR
#1	1
#2	2
#3	4
#4	8
#5	16

If you want to dispense 10 dimes per dollar turn "ON" switches 2 and 4. (2 coins + 8 coins = 10 coins.)
If you want to dispense 20 nickels per dollar turn "ON" switches 3 and 5. (4 coins + 16 coins = 20 coins.)

DipSwitch #6 is for giving extra coins for every \$5.00 bill input. This is for a token bonus mode pay out. If you are giving 4 coins per dollar, then 4 extra coins are given. If you are paying 5 tokens per dollar, 5 coins are given extra. This is the only bonus mode available in the 1000/1001 series changer.

EXAMPLE: With dip switch #6 “ON” and a 4 coin per dollar pay out this will be the amount dispensed for each bill denomination.

\$1.00 bill	4 coins
\$5.00 bills	24 coins
\$10.00 bills	48 coins
\$20.00 bills	96 coins

Dip switches 7 and 8 should remain in the “OFF” position.

FUSE

High voltage fuse: This is the primary transformer AC fuse for the main logic board and the validator. Any direct short of the Transformer or validator will cause this fuse to blow. Replace this fuse with a 1-amp GDC fuse only. **REPLACING THIS FUSE WITH ANYTHING OTHER THAN A ½ AMP “AS” MAY RESULT IN A FIRE OR AN UNSAFE WORKING CONDITION!!** (See fig. 1 for location of this fuse.)

Functional Description of the Series AC1000 Changer

To follow along with this walk-through of your changer, fill the hopper with coins and turn the changer on.

- When power is applied the validator will cycle twice, the out-of-service LED flashes then goes out. The green LED on the main logic board comes on steady, and the red LED on the main logic board will light then go off then flicker on once per second in the standby mode.
- During the power-up mode the main logic board relay clicks twice enabling power (120vac) to the validator. When this relay is not enabled it routes 12vdc ground to the out-of-service LED. Without any power to the validator the changer cannot accept bills. Since we are not in the error mode, the red LED on the validator logic board is on steady.
- When a bill is inserted into the validator bill slot, the bill will be pulled inside. The validator then compares what the bill looks like to its memory. After the bill is validated it grounds the 5vdc lines causing a pulse along the yellow and blue validator harness wires to pins 5 and 6 of the main logic board. Each pulse stands for the amount of the denomination validated. (i.e. 1 pulse for \$1, 5 pulses for \$5).
- The 5vdc pulse then travels from pins 5 and 6 to the EPROM chip (MONO-A40) pin #25. The EPROM sends a 12vdc pulse to the meter chip (U5) out pins #21 & 22 (one pulse per denomination validated).The EPROM also multiplies the bill pulse by the DIP switch settings (The EPROM reads the DIP switch settings during the power up mode and stores them into memory.)
- The EPROM then sends the hopper pulses out pin #23 to pins 6 and 7 of the red 12-pin hopper plug. These pulses travel through the purple and brown wires of the hopper wire harness to the hopper pins 8 and 12.
- The hopper turns itself on with the first hopper pulse. The hopper counts the hopper pulses sent from the EPROM chip on IN3 (pin 12) while dispensing the coins at the same time. When the amount of hopper pulses in equals the coins dispensed through the coin counting optical sensor the hopper turns itself off.

- The Changer returns to the standby mode with the red LED flashing once per second until another bill is inserted.

NOTE: THE METER ON THE MAIN LOGIC BOARD CANNOT BE RESET TO ZERO!!!

Functional Descriptions of Out-of-Service Conditions

Out-of-Service conditions occur for the Series 1000 changer for the following reasons; low coins, hopper fault error, validator fault, or a blown fuse.

- Blown Fuse:** an AC power spike in line voltage or a bad transformer on the main logic board can cause A blown fuse on the main logic board. If either fuse blows the indication is the green LED on the main logic board will not light.
 - Replace the fuse. If the green LED now lights then there was a spike.
 - If it does not and the fuse blows again the power transformer is shorted. To test the transformer use a voltmeter set for ohms and measure across the primary (40ohms) and the secondary (1.5ohms).
- Hopper Fault:** A hopper fault can either be a jammed hopper, a blocked coin counting optic or a bad hopper logic board.
 - Indications for a jammed hopper are the changer accepts bills, the meter counts up, but nothing or not enough coins are paid out.
 - After 2 minutes the EPROM shuts off the validator if the coins are not paid out correctly. The “Empty” LED will flash once per second.
 - At this point the three options open are to attempt repair on your own, call your distributor, or return the hopper to American Changer.
 - Indications for a blocked coin optic or bad hopper logic board are the out-of-service LED on the outside of the changer is lit and the red LED on the main logic board is lit and flickers off once per second.
 - If two of the 3 green LED’s on hopper logic board are lit then the hopper logic board is bad.
 - If there is a coin or foreign object caught in the coin exit window LED’s #1 and #3 will be lit on the hopper logic board instead of LED’s #1 and #2.
 - Take off the side of the hopper with 5 Philips screws. Pull up on the exit window logic board and look for the jammed item.
 - Ensure you have the pins aligned before reconnecting logic board.
- Validator Fault:** When a validator fault occurs the validator’s EPROM shuts down the validator and flashes an error code via the red LED on the validator logic board. When there is no error this LED is on steady. The validator only gives bill pulses to the main logic board so the main board never knows if the validator isn’t functioning. Therefore the out-of-service-LED will not light. (Seepage for validator error codes.)

4. **Low Coins:** The low coin condition is probably the most common fault. The EPROM on the main logic board is constantly checking for low coins in the hopper. This is done with a low current 5vdc signal on pin #3 of the hopper output connector. The voltage then travels down the hopper wire harness on the white wire to pin #7 of hopper plug. The signal is applied to one of the gold low contact plates at the bottom of the hopper. The 5v travels through the coins through the other contact gold plate to hopper pin #2. It then goes through the black wire in the hopper harness to pin #10 on the main logic board. Any interruption of more than 1/2 a second will cause an out-of-service condition.

- A. Clean the bottom gold plates of the hopper with steel wool or fine sandpaper. Refill the hopper and try again.
- B. Check continuity, (0 ohms) resistance, from pins 3 (white) and 10 (black) of the red hopper harness. Make sure the hopper full and the changer turned off.
 1. If the continuity is 0 ohms, replace the main logic board.
- C. Pull the hopper out of the changer, then look at the 12 pin black male connector that sticks out of the hopper. Place the continuity checker's leads on pins 2 & 7.
 1. If the continuity is 0 ohms, replace the hopper plate or adjust the hopper plate's female socket's pins so that they are not so spread out.
 2. If the continuity is infinity, then replace the hopper.

Indicator Lights

Main Logic Board:

1. Green LED on: AC power applied to the logic board. All fuses are good.
2. Red LED
 - A. Heartbeat - 5 and 12vdc present. The changer is in standby waiting for a bill pulse.
 - B. On Steady - Out of service, Hopper error detected.

Validator logic board:

1. Red LED
 - A. On Steady - Standby Mode, waiting for bill insertion.
 - B. Flashing - Error mode, go to page for error code information.
 - C. Off - The changer "Empty" LED is lit.

WIRE HARNESS COLOR AND DEFINITIONS

Validator harness:

- Red - Switched Hot 120VAC.
- White - Neutral 120VAC.
- Black - 120VAC Low current validator enable.
- Yellow - +5vdc credit pulse line.
- Blue - -5vdc credit pulse line.
- Orange - +12vdc Empty LED.
- Brown - -12vdc Empty LED.

Hopper Harness

- Gray - Coin counting optic status line.
- White - Low coin sense (+5vdc).
- Green - Coin counting optic pay out feedback line.
- Yellow - Raw sensor output line.
- Purple - Hopper pay out line from main logic board (+).
- Brown - Hopper pay out line from main logic board (-).
- Red - +12vdc logic board supply voltage.
- Black(s) -12v, 24v low coin sense ground.
- Orange - +24vdc Motor supply voltage.

Coin Control Hopper MKIV

Three green LED indicators are fitted on the hopper and are visible in the section where the coins exit the hopper. From left to right these are designated as follows:

1. Logic power supply on (12 & 24vdc present).
2. Security optical obstruction indicator -. Should be "on" when unit is OK.
3. Output indicator, indicates coin passing photo-sensor. This is the optical sensor the coin will obstruct on its way out of the hopper. For normal operation LED # 3 will be off until coins are dispensed.

Coin/Token Sizes

The hopper will automatically adjust to dispense coins/tokens in size from 20-30 mm in diameter and 1.25 - 3.5 mm in thickness.

There is an option available to dispense smaller coins.

A nickel is approximately 21 mm, a quarter is approximately 25mm. A Susan B. Anthony is 28mm

HOPPER ERROR CODES



With the digital display the logic board is now able to convey exactly why the "Empty" LED is lit. Press the "Dump" button **while the "Empty" LED is lit**. On the Light-up display the meter count will go away while holding the button down. These are the error code definitions:

- 1---- - Hopper was shut down completely.
- 2--- - Hopper Exit Window LED is blocked.
- 3-- - Low Coin Failure.
- 23-- - Hopper is not Plugged into the Hopper Harness.
- 4- - Hopper is Jammed.
- 5 - Hopper Overpaid 2 Coins and was shut down.

Refer to the Troubleshooting section of this manual to repair these failures.

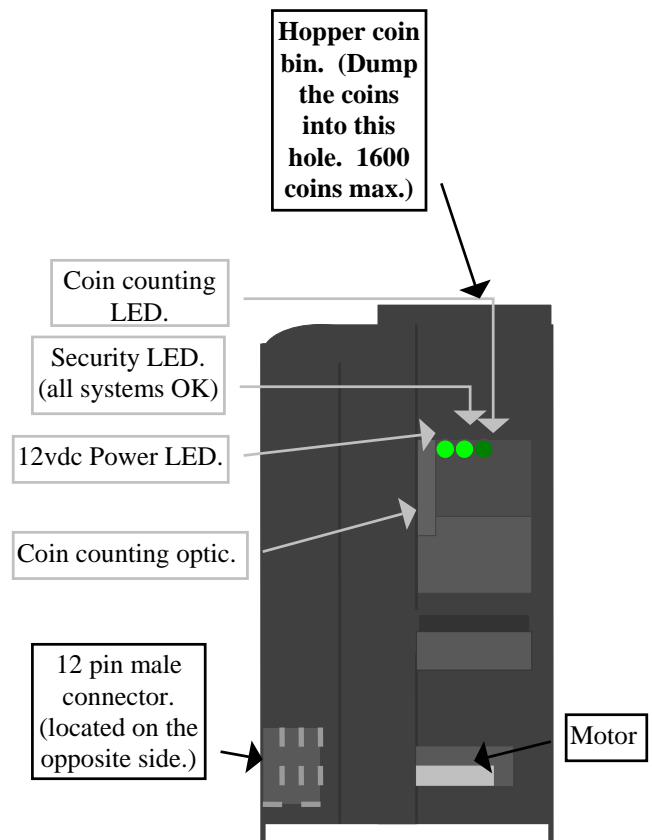

VALIDATOR INTERFACES

18 PIN INTERFACE CONNECTOR DETAILS

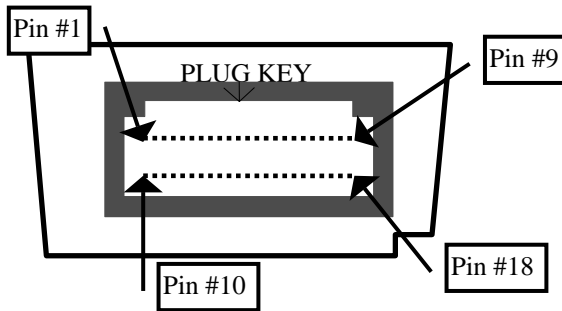

Interfacing the Mars 2501/2511 Series with the ValiChanger

8-Position Switch

1	off
2	on
3	off
4	on
5	off
6	on
7	off
8	off

No change is required to the 18-pin connector.

Ensure the black & yellow wires go to a wire nut and the green & white go to the other wire nut

Interfacing the Mars 2601/2611 Series with the ValiChanger

8-Position Switch

1	on
2	on
3	on
4	on
5	off
6	on
7	off
8	off

The 18-Pin interface connector is not needed.

Interfacing the Mars AL-4 or AL-4 Plus Series with the ValiChanger

8-Position Switch

1	on
2	off
3	on
4	on
5	on
6	off
7	off
8	on

4-Position Switch

1	off
2	off
3	off
4	off

The 18-pin connector is not required.

Interfacing the Maka NB-10 with the ValiChanger

To interface the Maka NB-10 validator with the ValiChanger the following settings should be used for the "\$1 = one pulse" configuration. See the validator manual for full details. The 18-pin interface connector should not be used.

Interfacing the Maka NB/NBE-20 with the ValiChanger

To interface the Maka NB/NBE-20 validator with the ValiChanger the following settings should be used for the "\$1 = one pulse" configuration. See the validator manual for full details. The dipswitch settings should be:

6-Position Switch

1	on
2	on
3	off
4	off
5	off
6	off

The 18-pin interface connector supplied with the ValiChanger should have pins 3, 4, 14, 15 & 18 connected and pins 7,9,12 connected.

Interfacing the CoinCo BA30SA with the ValiChanger

Connect wires 4 & 12 (Black & Red) to gather on the 18-pin connector to enable the Validator. If the validator pulls the bill 1/2 way in and stops change dipswitch #3 on the bill validator logic board.

CoinCo MAG Series Flash Codes

Flash codes 1-18 may appear during normal servicing of the BA30. If more than one error or condition exists, the lower number flash code will appear until its respective error or condition is corrected. The left and right sensors referenced below are given viewing the BA30 from the front.

# of Flashes	Description of Flash Codes
1	Bill box full
2	N/A
3	Check bill path
4	All bill accept switches are off
5	Bill jam or sensor error
6	Stacker motor/home sensor
7	Transport motor/encoder sensor
8	N/A
9	EEPROM Has Failed
10	EEPROM Has Failed
11	Center Optic Failed
12	Right Optic Failed
13	Left Optic Failed
14	Bill Position Sensor Error
15	Right Bill Position Sensor Error
16	Left Bill Position Sensor Error
17	Lower Anti-Stringing Armature out of place
18	Upper Anti-Stringing Armature out of place

MAG BILL ACCEPTOR

Operation and Service Manual



COINCO MAG50B VALIDATOR SECTION

	PAGE
Removing the Bill Box	10
Clearing a bill jam	10
Setting the bill types accepted	11-12
Cleaning the sensors	12-13
Cleaning a salted unit	13
Replacing the belts	14



Removing the bill box.

To remove the 1000 bill stacker from the CoinCo validator follow the picture below.

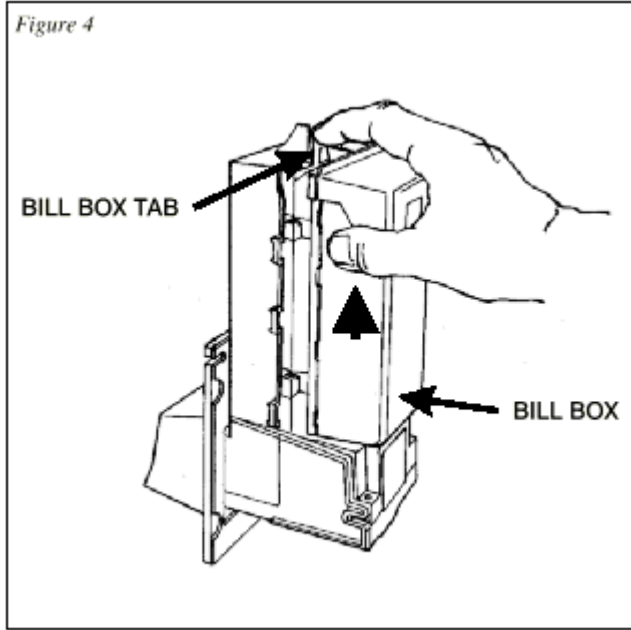

REMOVING A BILL JAM

From time to time a foreign object or ripped bill will become caught in the validator. Follow the picture below to remove the item.

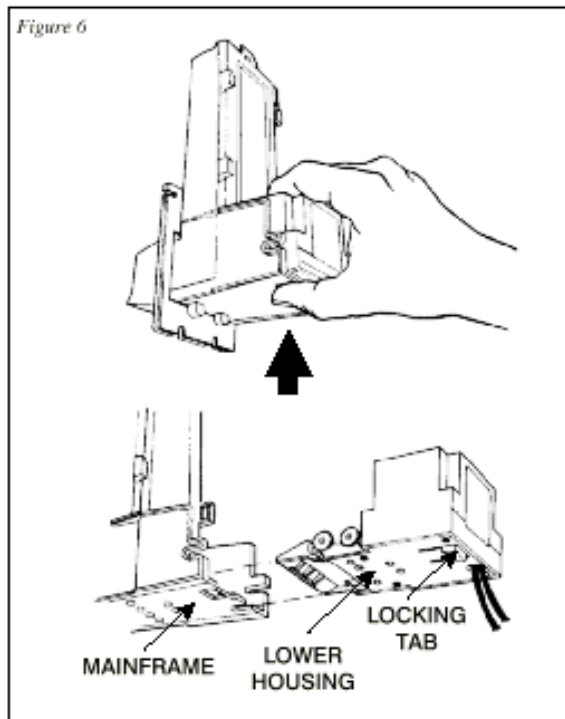

SETTING THE BILL ACCEPT DIP SWITCHES

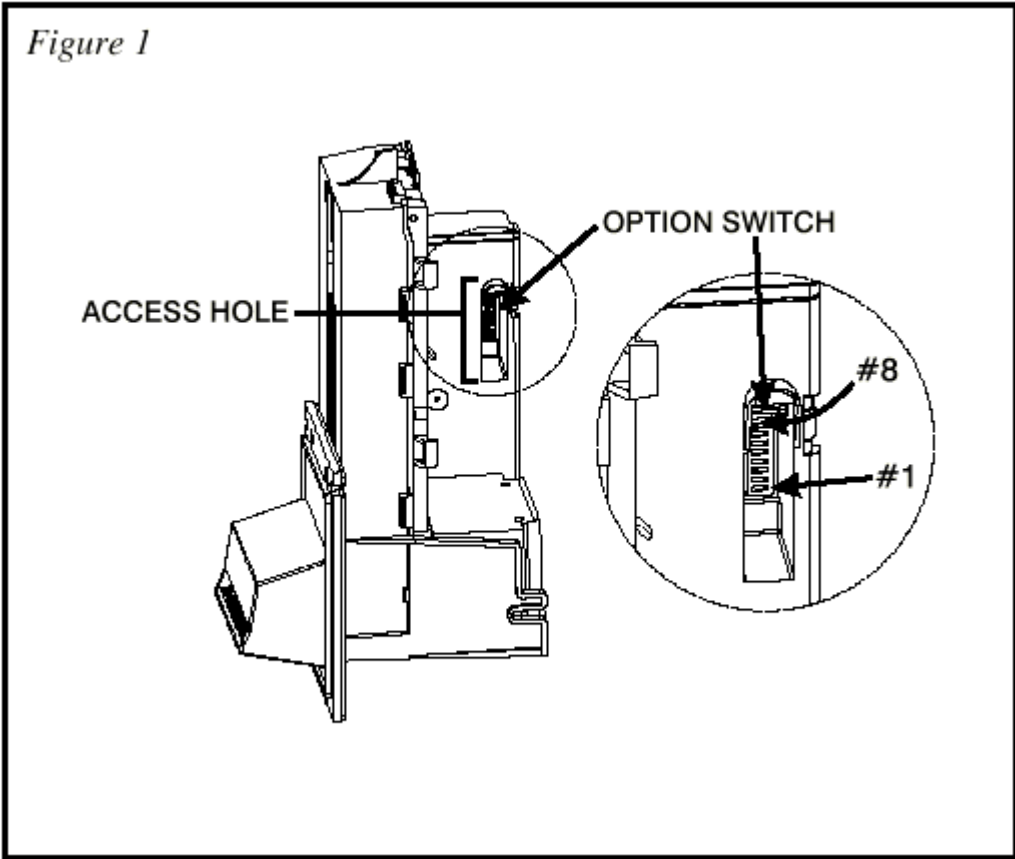
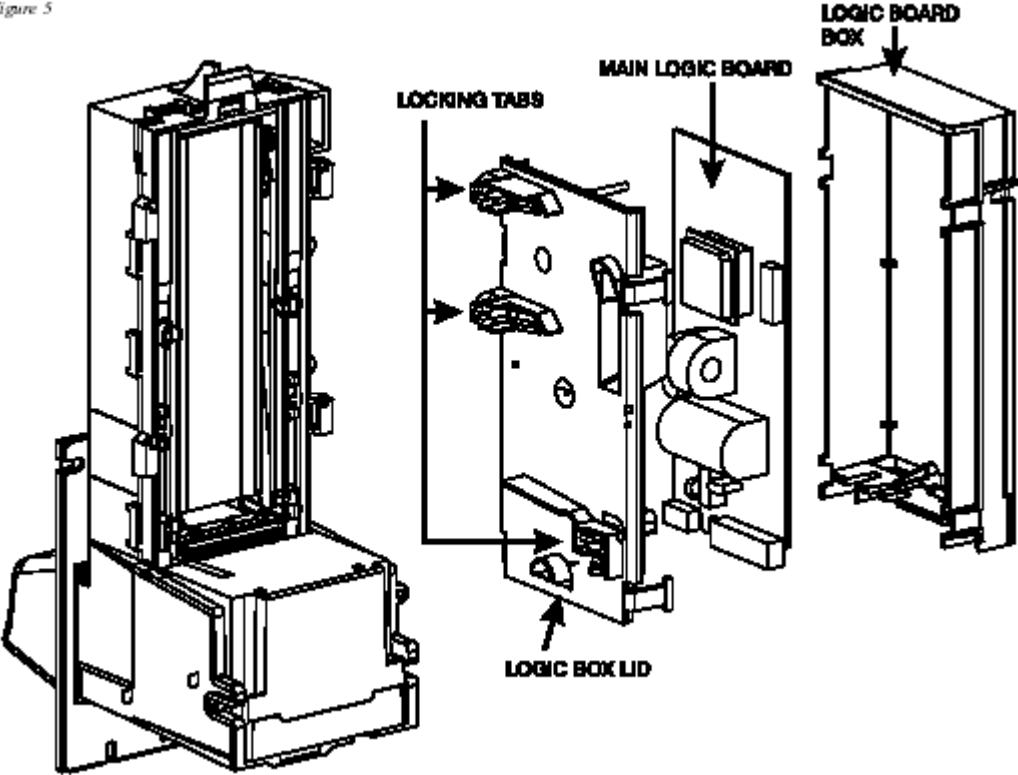
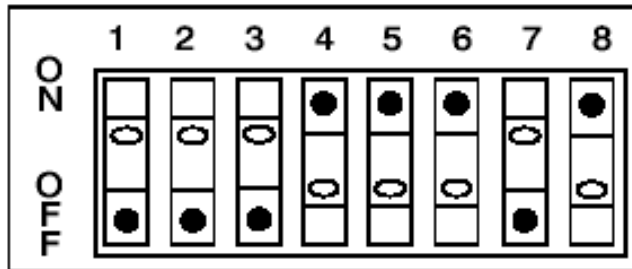

Figure 5



SWITCH	ON	OFF
1	High Security	Standard Acceptance
2	Accepts bills in one directions only (face up, green seal first)	Accepts bills in both directions (face up)
3	Standard credit pulse 150ms on 150ms off	Short credit pulse 50 ms on 50 ms off
4	\$20 Accept	\$20 Reject
5	\$10 Accept	\$10 Reject
6	\$5 Accept	\$5 Reject
7	\$2 Accept	\$2 Reject
8	\$1 Accept	\$1 Reject



CLEANING THE BILL VALIDATOR

Refer to the pictures and the procedure on the next page to clean the bill validator every 4-6 months.

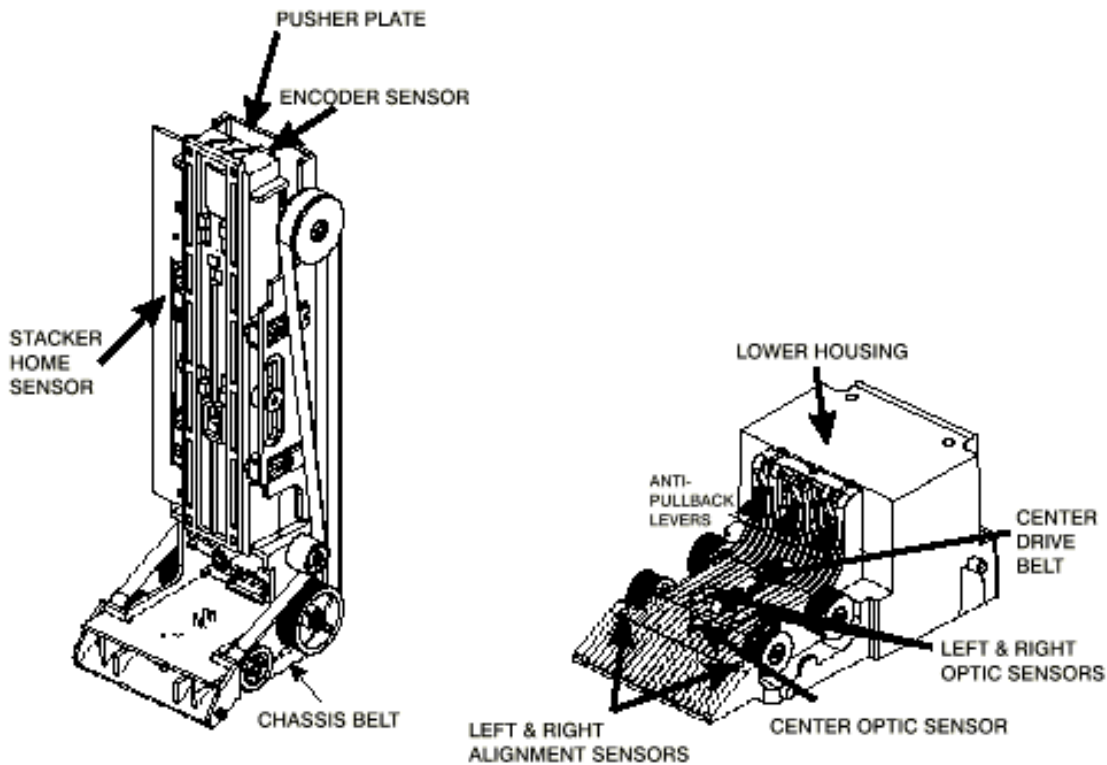

MAGPRO CLEANING: IF ANY OF THESE PROCEDURES ARE PERFORMED TO YOUR VALIDATOR AFTER IT IS RETURNED UNDER A WARRANTY REPLACEMENT, YOU WILL BE SUBJECTED TO A \$65.00 LABOR FEE.

CLEANING AND MAINTENANCE:

Note: *Petroleum-based cleaners and freon-based propellants can damage plastic and some electronic components. Scouring pads and stiff brushes may harm the protective conformal coating on the circuit boards and can mar the plastic. These items should never be used when cleaning the MAGPRO bill acceptor.*

The MAGPRO should be cleaned every 7,000 bills or every 4 -6 months (or as needed, depending on the environmental conditions of the location). Dust can be removed with a soft brush or cloth or it can be blown out using compressed air.

Procedure:

1. Disconnect power from the bill acceptor.
2. Remove the bill box and use a soft cloth to wipe the dust from around the intermediate frame and stacker plate.
3. Remove the lower track.
4. Using compressed air or a soft brush, blow or brush the dust off of the optic sensors and out of the recessed sensor openings.
5. Remove dust from around the belts and wheels on the lower housing and the sensors on the upper sensor board. The upper sensors are located directly above the lower housing sensor when the lower housing is installed.
6. The bill path can be cleaned to remove further dirt and oil using a soft cloth moistened with a mild soap and water solution.
7. Clean the magnetic head using a swab and isopropyl alcohol.
8. Once the lower housing is dry, place it back into the mainframe so that the tab on the bottom locks into place.
9. Blow the dust out of the encoder wheel and its sensors. (It may be necessary to extend the stacker plate to access the encoder wheel. Supplying power to the unit momentarily can do this, so that the stacker plate extends.)
10. Remove dust from the transport belt areas and from any other places of build up.
11. Remount the bill box.
12. Apply power and insert bills to verify that the unit is functions property.

MAGPRO CLEANING PROCEDURE FOR SALT WATER POLLUTED UNITS:

Note: *Petroleum-based cleaners and freon-based propellants can damage plastic and some electronic components. Scouring pads and stiff brushes may harm the protective conformal coating on the circuit boards and can mar the plastic. These items should never be used when cleaning the BA30 bill acceptor.*

Procedure:

1. Remove power from the bill acceptor.
2. Remove the bill acceptor from the vending machine.
3. Open the bill box lid and verify that the stacker plate is in the stand-by/home position. If it is not in the home position, apply power and observe that the stacker plate returns home.

Warning: *If moisture is present, allow the unit to dry thoroughly before applying power to avoid possible shock hazard. If the stacker plate does not return to the home position, remove power and*

carefully remove the bill box to avoid damaging the bill box and/or stacker plate.

4. Remove the lower housing.
5. Remove the bottom cover from the lower housing.
6. Run hot water (1101/4-1401/4F) over the lower housing from the top and bottom. Using a soft brush, gently clean any residual salt. Use a soft absorbent cloth to clean any residue off the lower housing. If the transformer gets wet, allow the unit to dry for 24 hours before applying power.
7. Remove the front mask. Using hot water and a soft brush, clean the front mask, upper sensor board, main frame anti-pullback levers and position sensor mount.

Caution: *The motors are not protected from water, therefore the unit must be held in a manner that prevents water from running over the intermediate frame crossbar.*

8. Remove the position sensor cover on the crossbar and carefully lift the LED from its mount. (Early models only.)

Caution: *Protective coating on the LED leads should not be damaged. Clean all salt residue from the mount, sensor hole and detector area.*

The detector can be seen through the sensor hole, and is located in the chassis. Replace the position sensor cover. (Early models only.)

9. Verify that the anti-pullback levers move freely and that the spring returns them to their open position.
10. Allow the unit to dry thoroughly.
11. Clean the magnetic head using a swab and isopropyl alcohol.
12. Replace the front mask
13. Replace the lower housing cover.
14. Replace the lower housing into the main frame.
15. Remount the bill box.
16. Apply power and insert bills to verify that the unit is functioning properly.

6 OR 7 ERROR CODE FLASHES

The cleaning procedure for this common occurrence is listed below. Just follow these steps.

1. If this code has occurred on a new machine or one that the validators DIP switches were just changed, Ensure that all the white plugs on the side of the validator board away from the red LED are plugged in securely.
2. Remove the bill box.
3. Turn the Changer ON then OFF in an attempt to stop the metal push plate so that it COASTS into the fully outward position.
4. Using an air compressor or a can of compressed air blow out the area behind the push plate until it is completely free of all dust and lint.
5. Turn the changer power back on so that the push plate returns to the inward position. If the same error code persists, repeat steps 1 -

3 concentrating on the top center area behind the plate.

1. Replace the bill box.

6.

REPLACING THE BELTS

Every 2-3 years the belts on the CoinCo will wear out. To replace them, remove the validator components down to the picture show. Refer to the parts diagram at the end of the manual for help getting to this point.

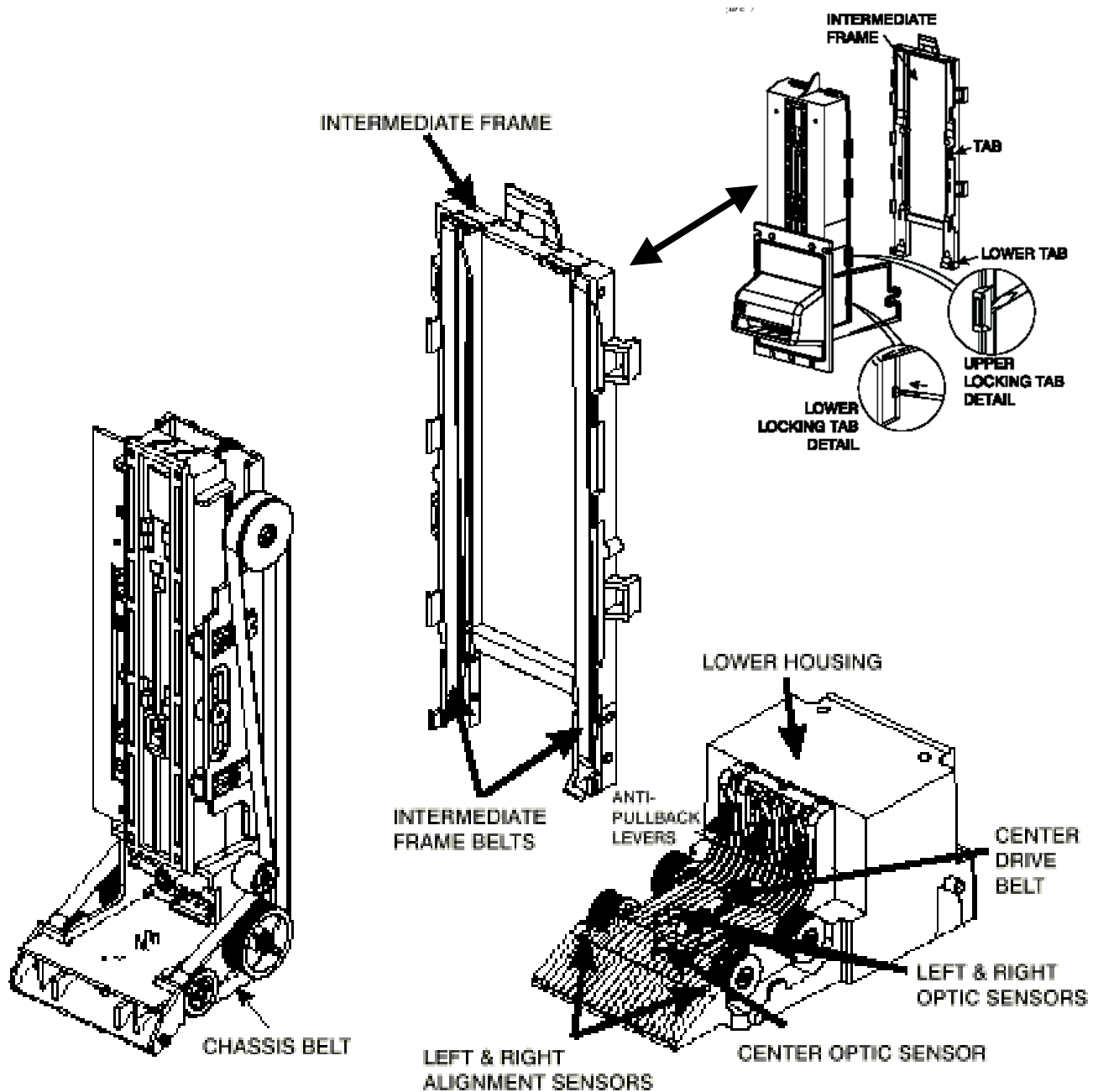

MEI MARS AE2601 BILL VALIDATOR



MEI MARS AE2601 VALIDATOR SECTION

	PAGE
Removing the Bill Box	16
Clearing a bill jam	16
Setting the bill types accepted	17
Coupon Programming (Dip Switch)	18
Cleaning the Validator	19
Trouble Shooting & Trouble Codes	20

In order to use the Mars type VN2611 type validator the hopper extensions must be removed in order for the machine door to shut.

This is not a problem when using the Mars VN2601 style validator!

OPERATIONS MANUAL

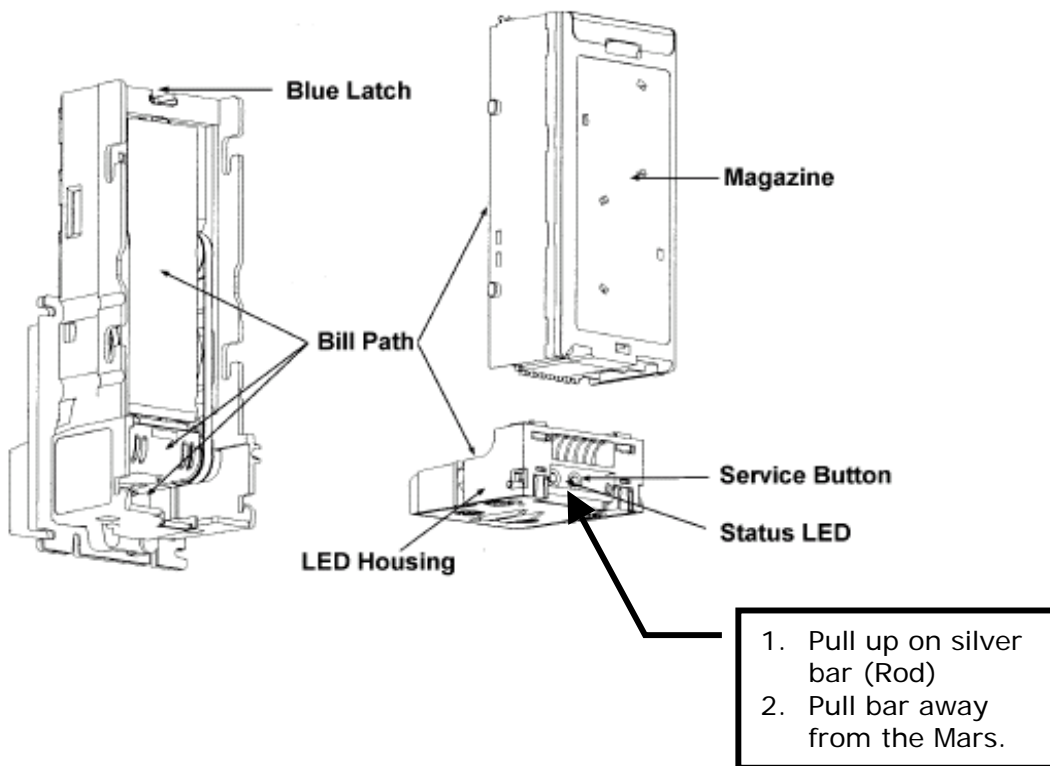
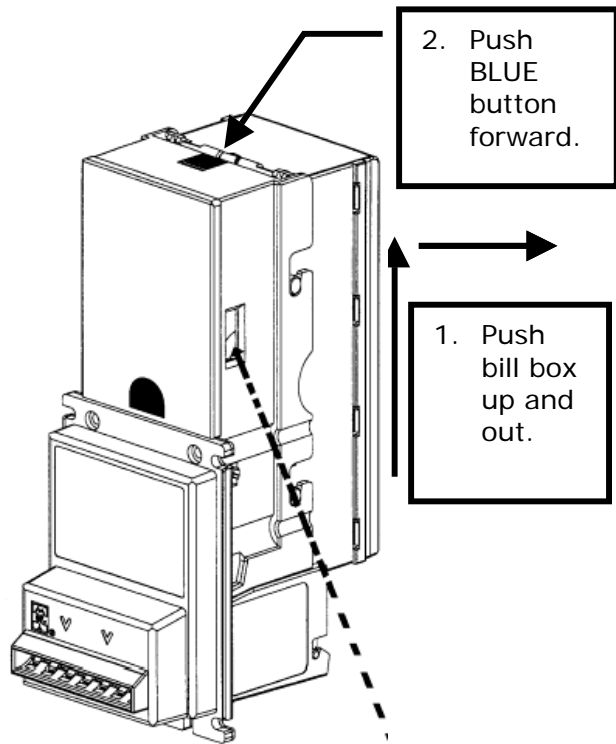

			Factory Default
Switch 1	Switch 2		
ON	OFF	1 Way Bill Acceptance	
OFF	ON	2 Way Bill Acceptance	
ON	ON	4 Way Bill Acceptance	X
Switch 3*			
OFF	High Security		X
ON	High Acceptance		
Switch 4			
ON	Rejects \$ 2 Bills		X
OFF	Accepts \$ 2 Bills		
Switch 5			
ON	Rejects \$20 Bills		
OFF	Accepts \$20 Bills		X
Switch 6			
ON	Always Enable		X
OFF	Harness Enable		
Switch 7			
ON	4 Pulse Per Dollar		
OFF	1 Pulse Per Dollar		X
Switch 8**			
ON	Vending Interfaces		
OFF	Gaming Interfaces		X
<p>* Switch 3 affects all denominations. See Coupon Configuration on page xx for individual acceptance/security enabling options.</p> <p>** The AE2600 defaults to short pulse.</p>			

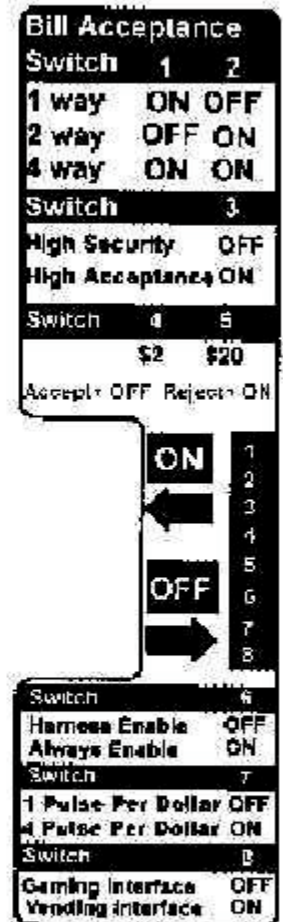

Coupon Configuration

The AE2601 may be configured using a coupon. The coupon is included in the AE2601 Series Installation Guide. Carefully cut the coupon along the dotted-line edge to remove it from the installation guide. Copies of the original coupon may be produced with a standard, carbon-based, non-color copier. Cut copies to match the size of the original coupon.

All option switches must be in the OFF position for the coupon selections to be active.

The coupon selection will remain with the AE2601 until the unit is reprogrammed, even if power is removed.

When filling out the coupon, note the following:

Use only a #2 pencil to fill in the blocks

Fill in the entire block

Do not mark the coupon outside the blocks or on the back of the coupon

Fill in **ONE** block for **EVERY** line

Coupon Programming

1. Fill out the coupon using the table below.
2. Locate the service button on the back of the unit (refer to Figure 2).
3. Press the button once to enter the coupon setup mode. Pressing again will exit the mode. The unit will automatically exit coupon setup mode upon acceptance of the coupon configuration.

The LED Status indicator (located to the left of the service button) will flash rapidly indicating that the unit is in coupon setup mode.

4. Insert the coupon marked-side up. The AE2601 will pull the coupon in, read it, and then return it to the user.

A good coupon will be returned immediately.

After the coupon is pulled from the bill acceptor mouth, the unit will flash the Status LED ten times to confirm a good configuration.

A bad coupon will be held for ten seconds before being returned. This delay is to make you aware that there is a problem with the coupon. When the coupon is pulled from the bill acceptor mouth, the unit will flash the Status LED the number of times corresponding to the section of the coupon wherein a problem lies. For example, if

THIS IS NOT A USABLE COUPON!

DO NOT COPY!!!

FIGURE 1

↑ Insert this end first ↑		
USE #2 Pencil Photocopy can be used	● ●	Complete sections 1-5 ONLY
	●	7
# of Bill Directions	□ □ □	1
	1 2 4	
\$1	□ □ □	2
	High Accept High Sensing OFF	
\$2	□ □ □	
\$5	□ □ □	
Pulse	□ □ □	3
	Short Long Credit Line	
Pulses per dollar	□ □ □ □	4
	1 2 3 4	
Bill lights Dry/Flashing	□ □	5
	ON OFF	
●		6
MARS Bill Acceptor		Model 2601 Configuration Clipboard 9871

FIGURE 2

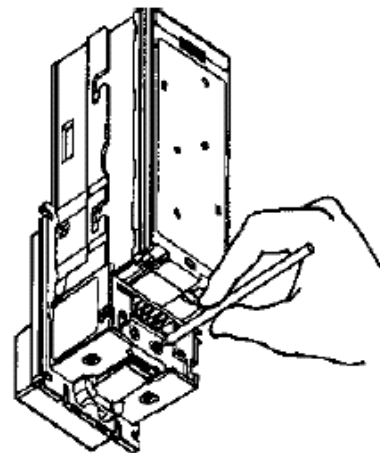

the problem is in section five, the LED will flash five times. Section numbers are located to the far right of each section on the coupon.

5. If the configuration is rejected, check the coupon and repeat the process.

Cleaning

You can clean the bill acceptor while it is still mounted in the machine (refer to Figure 3 below).

1. Remove power from the machine.
2. Unlatch the magazine by pushing the blue latch (located on the top of the unit) toward the front of the unit.
3. Unhook and remove the magazine by holding the latch and lifting up and then back on the magazine.
4. Unlatch the LED Housing by lifting up on the metal bar (located below the Status LED).
5. Remove the LED Housing by holding the metal bar and pulling back on the LED Housing.
6. Clean the bill path with a soft cloth. You may use mild, non-abrasive, non-petroleum based cleaners if sprayed on the cloth.

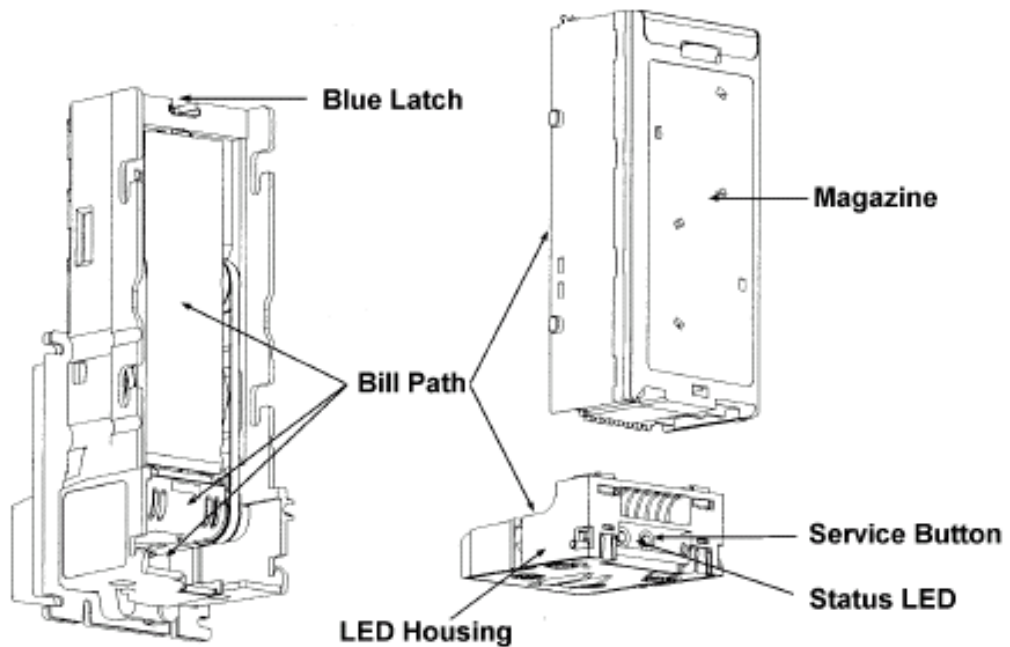

FIGURE 3

Status LED

A Status LED provides assistance in diagnosing the condition of the Series AE2601. The following is a description of the LED codes, their meanings, and suggested remedial actions.

Signal	Meaning	Solution
LED ON	Indicates that the unit is enabled and ready to accept a bill.	No action necessary.
LED OFF	Indicates that no power has been applied to the unit.	Check to ensure that power is applied.
1 Flash	Indicates that something is obstructing the bill path.	Remove the magazine and LED housing; inspect for foreign material.
2 Flashes	Indicates that the unit is not enabled.	Verify configuration. Check the coin tube levels in the coin changer. Check the option switches in the coin changer. Note: Many machines disable the bill acceptor if the machine door is open and the door switch is not activated or if the machine is out of product.
3 Flashes	Indicates that the bill path needs cleaning for optimum performance.	Remove the magazine and LED housing and follow cleaning instructions (page 22) to clean the bill path.
4 Flashes	Indicates that something is obstructing the bill path.	Remove the LED housing and look at the bill path on the housing and inside the unit for foreign material; clean as necessary.
5 Flashes	Indicates that the magazine is removed (the unit will not accept without the magazine attached).	Reinstall the magazine.
Continuous Slow	Unit is defective.	Replace the unit.
Continuous Fast	The magazine is full of money.	Remove the money from the magazine.

MKIV UNIVERSAL HOPPER

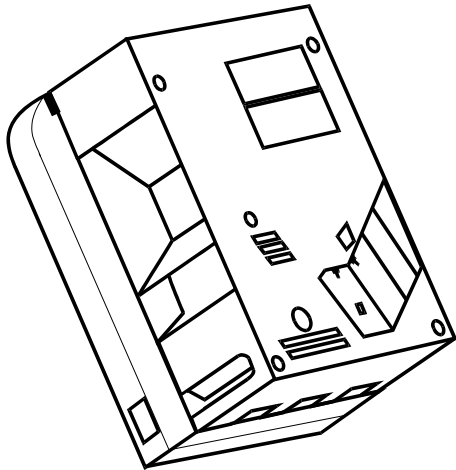

SERVICE MANUAL

INDEX

	PAGE
1. Coin box removal & reassemble.	22-24
2. Exit window replacement.	23
3. Logic board replacement.	24
4. End plate removal.	24
5. Track plate removal.	24
5a. Track plate assembly.	25
5b. Track plate replacement.	26
5c. Final drive gear replacement.	26
6. Gearbox assembly	27
7. Motor replacement.	27

To un-jam a hopper start with “End Plate Removal”, page 24-26.

1. COIN BOX REMOVAL

1. Place the hopper in front of you as shown, (looking at the outside of the 'coin box').

Refer to FIG 1.

2. Remove the 2 locking nuts, which hold the 'low level sense plate' wires to the studs.
3. Remove the crimp & wire from the studs.

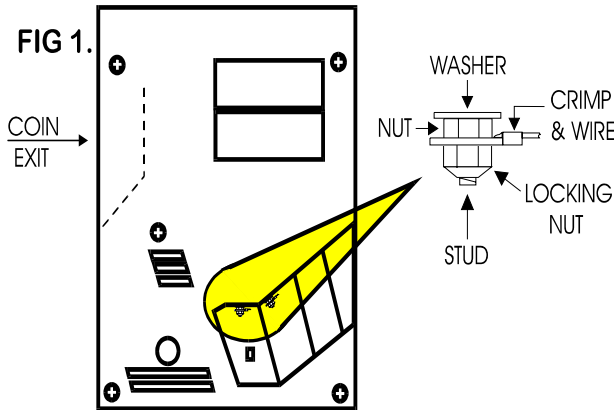

Refer to FIG 1a.

4. Remove the 5 screws indicated (B), which hold the 'coin box' to the 'center plate'.

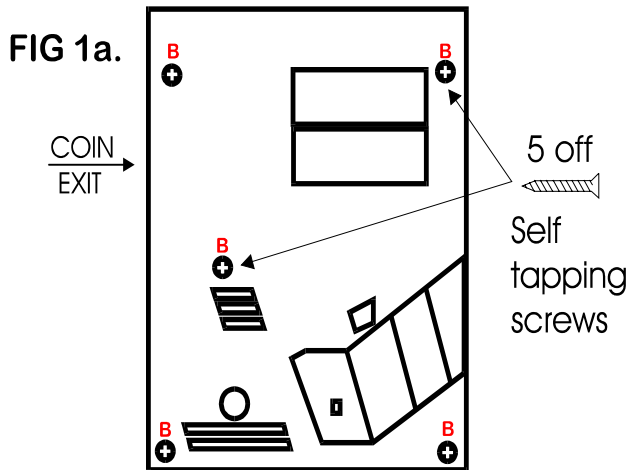

Refer to FIG 1b.

6. Gently lift the 'coin box' away from the rest of the hopper.

NOTE:- The 'logic board' & 'stirrer' are located in the 'coin box'.

7. As the 'coin box' is being removed, carefully slide the 'logic board' out. The stirrer may stay with the 'coin box' or fall onto the center plate.

FIG 1b.

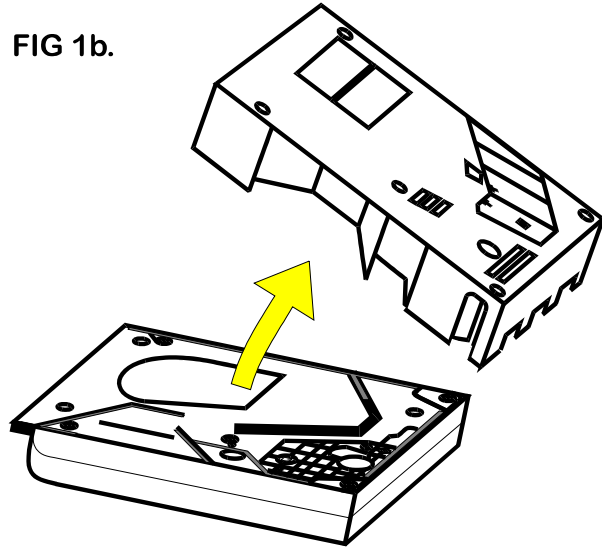

ACCESS IS NOW AVAILABLE TO THE 'LOW LEVEL' SENSE PLATES, THE MAIN PCB, THE EXIT WINDOW, THE MOTOR TERMINALS & PART OF THE WIRING LOOM.

1a. COIN BOX ASSEMBLY

1. Firstly, locate the 'stirrer' in the 'coin box' as shown in FIG 12.

FIG 12.

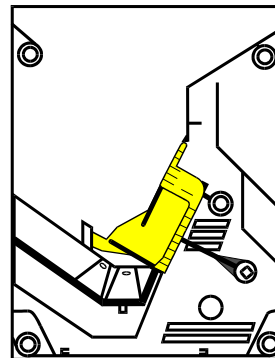
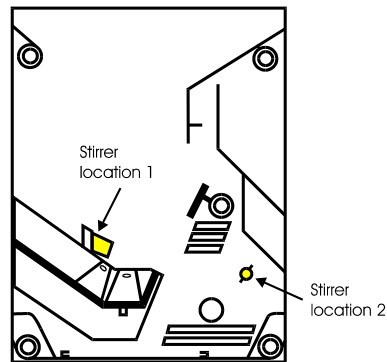

COIN BOX ASSEMBLY (cont.)

- Line up the 'centre plate' & 'coin box' as shown below. FIG 12a.
- Route the ribbon cable as shown below.
- Fit the 'logic board' into slots shown below.
- Feed the level sense wires through the slot shown below.

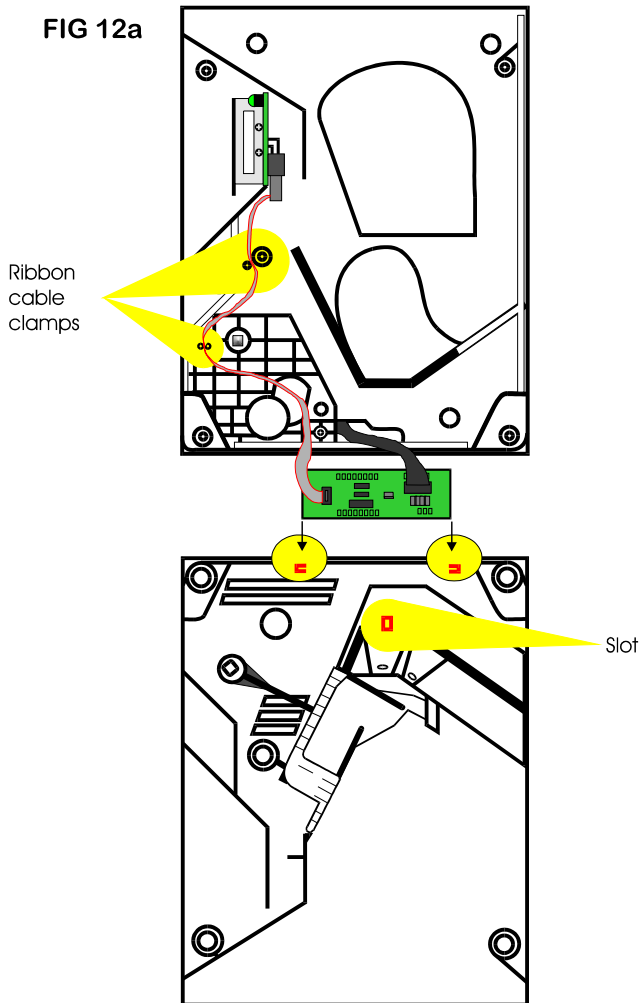

- Lift the 'centre plate' to meet the 'coin box'. FIG 12b & c.

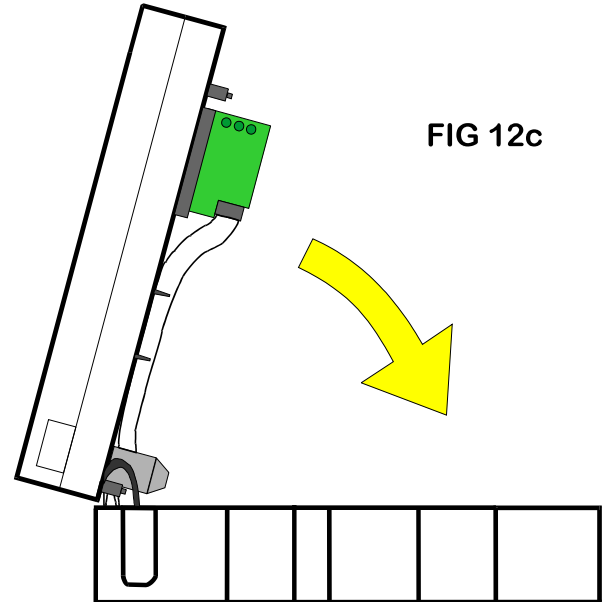
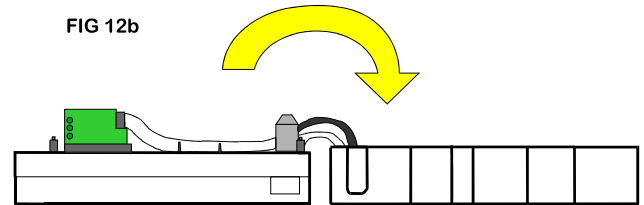

- Align the 'center plate' & 'coin box' & push together.
- Turn the hopper over & refit the screws.
- Refit the level sense wires.

2. EXIT WINDOW REPLACEMENT

- First, remove the 'coin box', section 1.
This will then enable access to the 'exit window'
- Unscrew & remove the 2 fixing screws. FIG 4.
- Remove the 'exit window' from the 'center plate'.
- Unclip & remove the 10-way ribbon cable header.

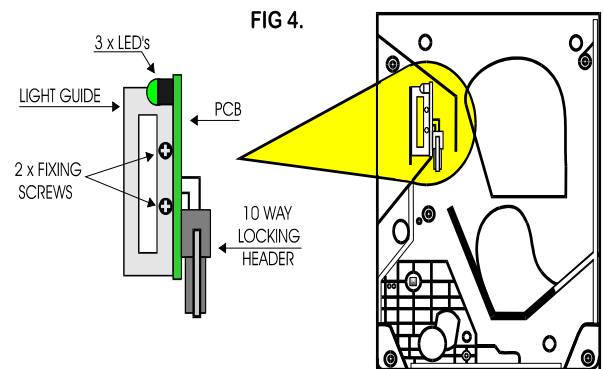

- To re-assemble, follow the above steps in reverse.

3. LOGIC BOARD REPLACEMENT

1. First, remove the 'coin box', section 1.

This will then enable access to the 'logic board'.

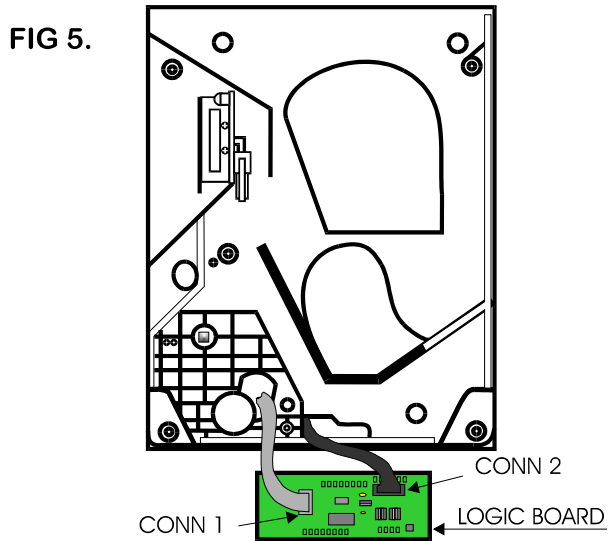

10-way ribbon IDC socket (CONN 1).

2. Move the two ejector arms at right angles to & away from the connector, if fitted.
3. This should release the socket from the header.
4. Clasp the connector between thumb & forefinger, pull away from pin header.
- 14-way crimp socket (CONN 2).
5. Gently, unclip the "friction lock" from the connector housing.
6. Clasp the connector between thumb & forefinger, pull away from pin header.
7. The Logic Board is now released.
8. To re-assemble, follow the above steps in reverse.

4. END PLATE REMOVAL

1. Place the hopper in front of you as shown, (looking at the outside of the 'end plate').

Refer to FIG 6.

2. Remove the 9 screws indicated (B), which hold the 'end plate' to the 'center plate'.
3. Locate the position of the 'connector blanking piece'.

4. Holding the 'connector blanking plate' gently lift the 'end plate' away from the rest of the hopper.

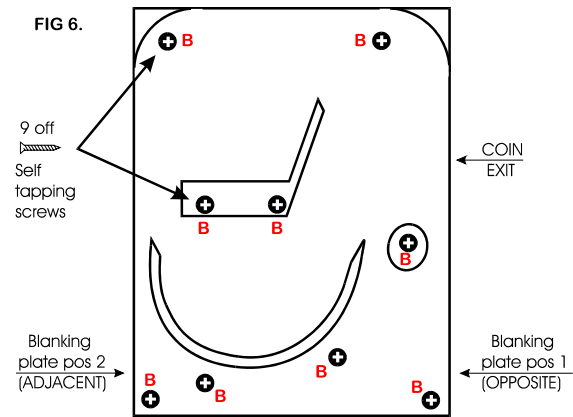

5. To re-assemble, follow the above steps in reverse.

5. TRACK PLATE REMOVAL

1. First, remove the 'end plate', section 6.

See FIG 7.

2. The 'elevator track' & 'final drive gear' can now be removed by lifting up & away from the 'center plate'.

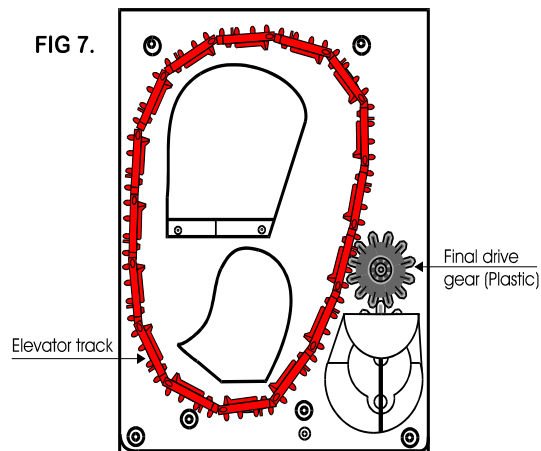

5a. TRACK PLATE ASSEMBLY

The following 3 sketches show how to take the 'track plate' apart.

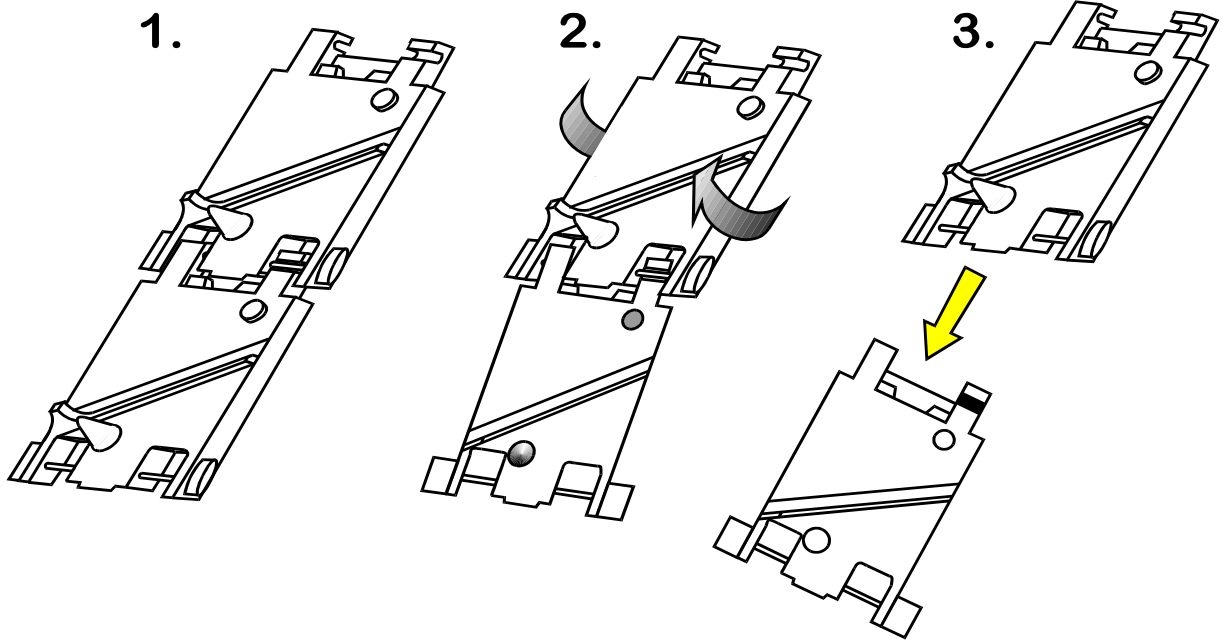

The following 3 sketches show how to assemble the 'track plate'.

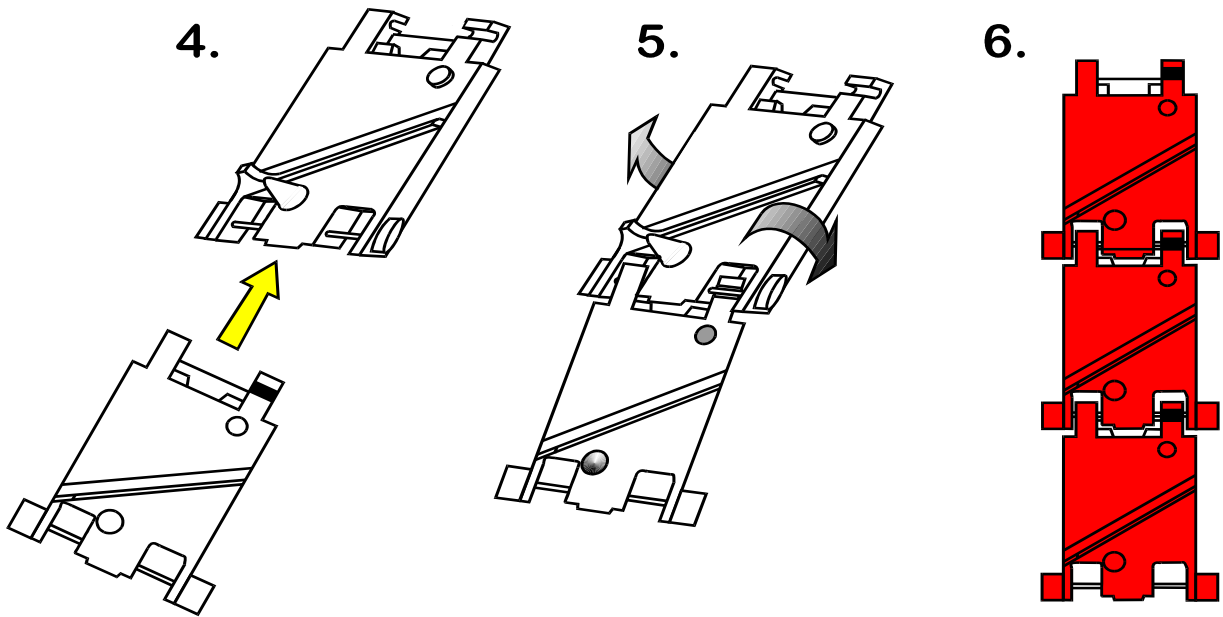

5b. TRACK PLATE REPLACEMENT

1. The gray shaded area, in FIG 7b, is the 'track plate' guide path.

FIG 7b.

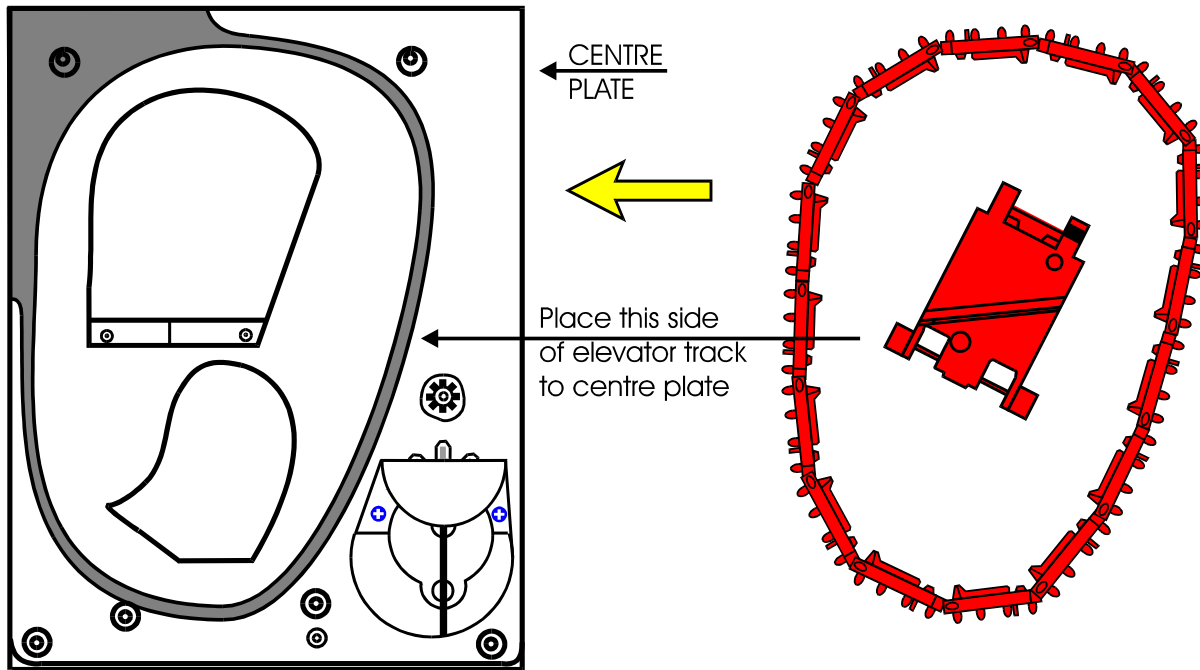

2. Once the 'track plate' is in position, turn the track through 720° to ensure it is seated in the guide path correctly.

5c. FINAL DRIVE GEAR REPLACEMENT

1. Once the 'elevator track' is in place, the 'final drive gear' can be fitted by placing the gear over its mounting spindle, while lining the teeth up with the secondary drive gear, adjust the 'elevator track' so that the gear falls into place. FIG 7c.
2. The end plate can now be re-fitted. See section 6.

FIG 7c.

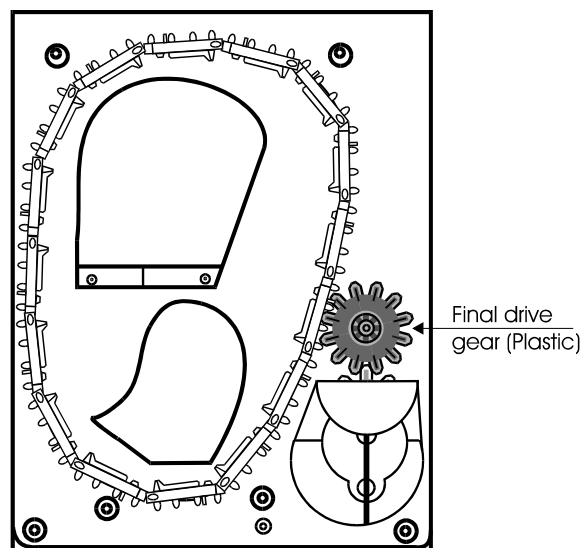

6. GEAR BOX ASSEMBLY

1. Remove the end plate. Section 6.
2. Remove the 'elevator track' & 'final drive gear'. Section 7.
3. Remove the gearbox cover. Section 8.

4. Remove the gears in the order as shown in FIG 9.

Access to the motor fixing screws is now possible.

5. To re-assemble, follow the above steps in reverse.

FIG 9.

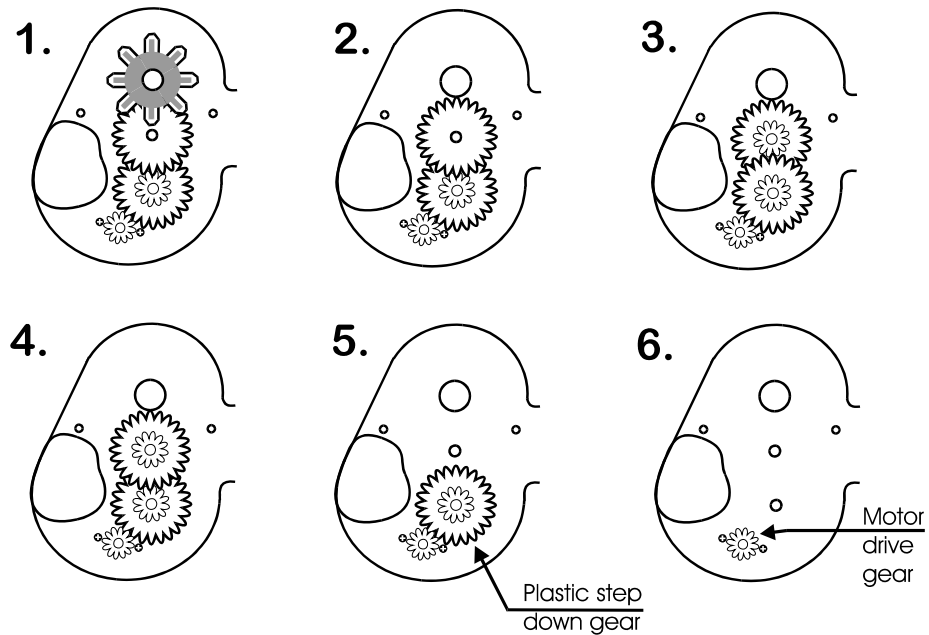

7. MOTOR REPLACEMENT

1. Remove the 'coin box'. Section 1.
2. Unsolder the red & black wires from the motor.

NOTE: The black wire connects to the terminal marked with a RED dot.

3. Remove the 'end plate'. Section 6.
4. Remove the 'track plate' & final drive gear. Section 7.
5. Remove the gearbox cover. Section 8.
6. Disassemble the gearbox. Section 9.

7. Unscrew the 2 motor fixing screws. FIG 10.

8. To re-assemble, follow the above steps in reverse.

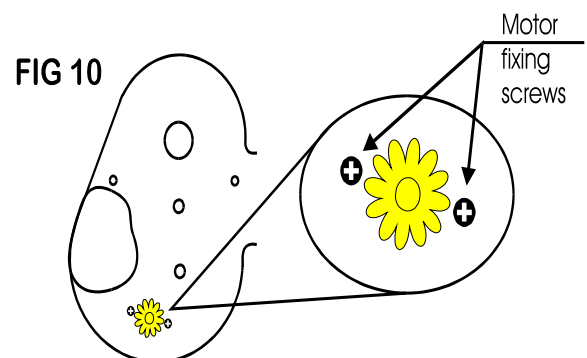

TECHNICAL FLOW DIAGRAM

Before starting this procedure ensure the changer is plugged in, the ON/OFF switch is on, the hopper is full of coins, and all wire harnesses are connected securely and correctly.

The wires exiting the red connectors should point away from the board!!

Start Here!!!

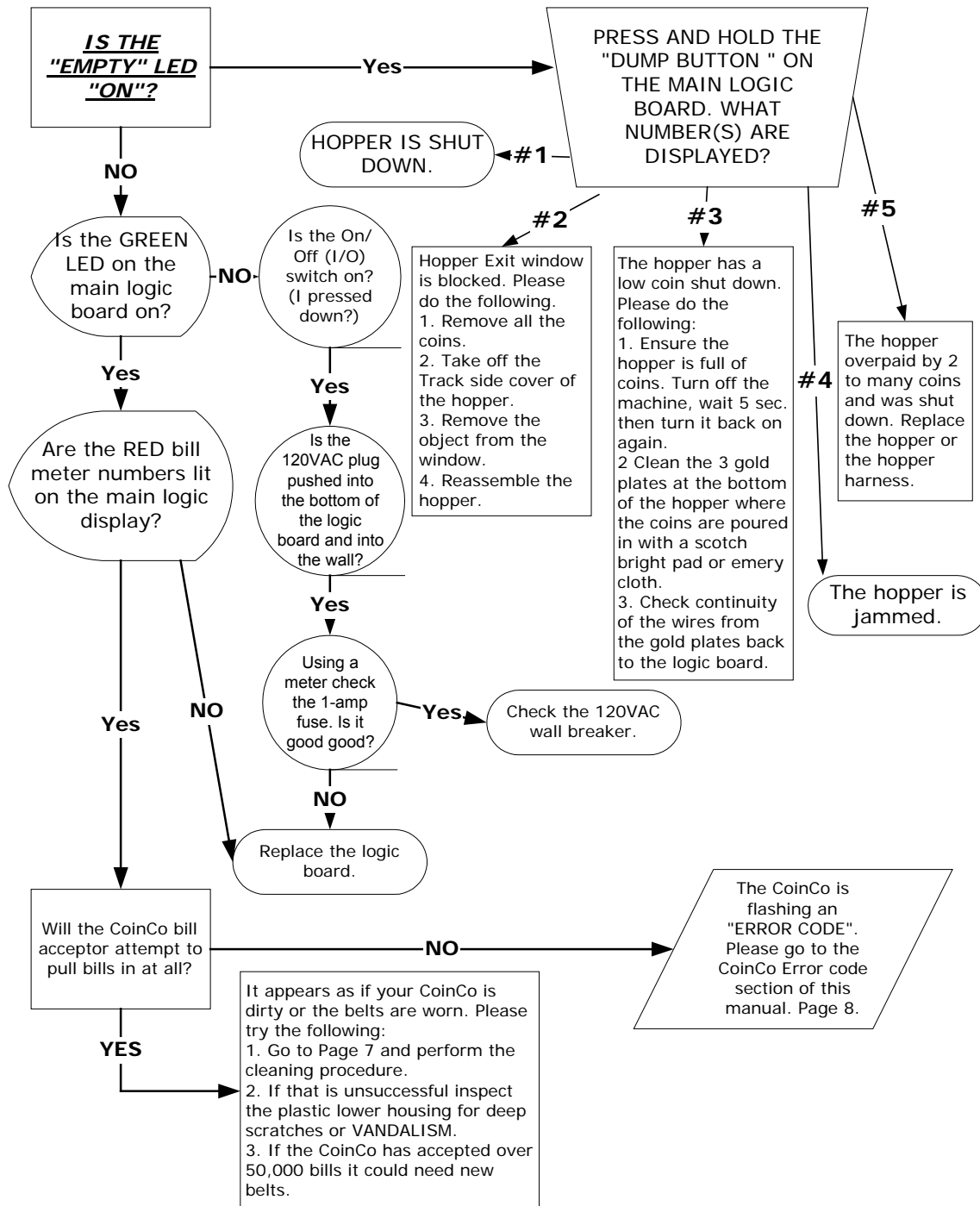

For a more detailed trouble shooting information proceed to the next section!

**FOR TECHNICAL SERVICE OR TO OBTAIN A RETURN AUTHORIZATION NUMBER
CALL (888)741-9840**

ANY REPAIR RETURNED WITHOUT A RETURN AUTH. # WILL BE REFUSED!!

TROUBLESHOOTING GUIDE

TO USE THE TROUBLESHOOTING GUIDE, MATCH UP THE PROBLEM, THEN FOLLOW THE SOLUTION SUGGESTIONS. After every step try operating the changer to see if the problem has been solved.

<i>Problem:</i>	<i>Solution:</i>
<p>A. The changer is completely dead. (The green LED on the main logic board is not lit.)</p>	<ol style="list-style-type: none"> 1. Ensure the changer is plugged in. 2. Ensure the on/off switch is rocked to the (1) position (down) . 3. Unplug the female end of the line cord from the main logic board AC connector and plug it in again tightly. 4. Measure the AC voltage at the outlet or check the breaker/fuse box. You can also plug another item into the AC wall outlet to ensure there is power present at the outlet. 5. Inspect the AC line cord for cuts or abrasions. 6. Check both fuses on the Main Logic Board. 7. Replace the main logic board. 8. Replace the line cord.
<p>B. The “Empty LED is lit. When the red LED on the main logic board is observed, the LED is flickering on briefly once per second.</p>	<ol style="list-style-type: none"> 1. Ensure the hopper is not out of coins. (There should be enough coins in the hopper to cover the gold low-level contact plates. These plates are located at the bottom of the hopper where you pour the coins.) 2. Check the hopper wire harness that extends from the back of the plate that the hopper slides in and out on for chipped pieces or other damage. (Pay close attention to pins # 2 & 7.) 3. Clean the gold contact plates with steel wool. 4. Replace the hopper. 5. Replace the hopper wire harness.
<p>C. The “Empty LED is lit. When the red LED on the main logic board is observed, the LED is on Steady.</p>	<ol style="list-style-type: none"> 1. Ensure the hopper is pushed into the hopper harness on the back of hopper plate tightly. 2. Ensure that left and center green hopper LED’s are lit only. Not the left and right LED’s. If this is the case go to pg. 19 to unjam the hopper exit window. 3. Replace the hopper. 4. Replace the hopper plate.
<p>D. The green LED on the main logic board is lit but the red LED never lights.</p>	<ol style="list-style-type: none"> 1. Bad 5 or 12vdc regulator on the main logic board. 2. The hopper is shorted. 3. Replace main logic board. 4. Replace hopper.
<p>E. The bill validator accepts and stacks the money but the bill meter never counts up.</p>	<ol style="list-style-type: none"> 1. Check continuity and for pin damage to the blue and yellow wires on the validator harness. 2. Replace the validator wire harness. 3. Replace the validator.
<p>F. The bill validator stacks the bills, the meter counts up, but the hopper does not pay out.</p>	<ol style="list-style-type: none"> 1. Ensure the dip switch settings are still correct. (#3 “ON” only) 2. Check the continuity of the brown and purple wires on the hopper wire harness. 3. The hopper is jammed. Go to pg. To unjam the hopper. 4. Replace the hopper wire harness.
<p>G. Bill validator will not pull in the bill and the “Empty” LED is not lit.</p>	<ol style="list-style-type: none"> 1. Ensure the orange wire going to the “Empty” LED is connected to the + or the terminal with the red mark by it. 2. Check for 12vdc going to the orange and brown wires. If there is, replace the LED. 3. Replace the main logic board. 4. Replace the bill validator. 5. Replace the validator wire harness.

TROUBLESHOOTING GUIDE

TO USE THE TROUBLESHOOTING GUIDE, MATCH UP THE PROBLEM, THEN FOLLOW THE SOLUTION SUGGESTIONS. After every step try operating the changer to see if the problem has been solved

<i>PROBLEM:</i>	<i>SOLUTION:</i>
H. The bill validator pulls in the bill slightly then rejects it.	<ol style="list-style-type: none"> 1. Clean the validator. (pg. 9) 2. Remove the lower housing (pg. 11) of the bill validator. Ensure the center wheel spins freely. Push straight down on it slightly to loosen.
I. The bill validator red status LED flashes a “5” error code.	<ol style="list-style-type: none"> 1. Clean the validator optic LED’s. (See pg. 9) 2. Ensure that all the wire harness plugs are plugged firmly into their white female sockets. 3. Turn to the back page of this manual and check for a Coin Acceptors branch in your area to repair your bill validator .
J. The bill validator red status LED flashes a “6 or 7” error code.	<ol style="list-style-type: none"> 1. Take the bill stacker off the bill validator. Cycle the power on / off using the switch on the main logic board and coast the silver push bar so that it stops in its fully extended position. Blow out the area behind the push bar with high pressure or canned air. Concentrate on the encoder wheel in the area top center behind the push bar. 2. Turn to the back page of this manual and check for a Coin Acceptors branch in your area to repair your bill validator .
K. The bill validators red status LED is on steady but it still will not accept the bill.	<ol style="list-style-type: none"> 1. Pull out the lower housing, see page , and look for something obstructing the bill path. (i.e. gum, papers, tickets, coins, etc.) 2. Look inside the Plexiglas case on the side of the bill validator. Ensure that all the wire harness plugs are plugged firmly into their white female sockets.
L. The red “empty” LED on the outside of the changer is on, the red status LED on the main logic board is flickering on and off normally, and the hopper is full of coins.	<ol style="list-style-type: none"> 1. Ensure the hopper is not out of coins. (There should be enough coins in the hopper to cover the gold low-level contact plates. These plates are located at the bottom of the hopper where you pour the coins.) 2. Check the hopper wire harness that extends from the back of the plate that the hopper slides in and out on for chipped pieces or other damage. (Pay close attention to pins # 2 & 7.) 3. Clean the gold contact plates with steel wool. 4. Replace the hopper. 5. Replace the hopper wire harness.
M. The red “Empty” led on the outside of the changer is flashing once per second.	<ol style="list-style-type: none"> 1. The hopper is jammed. 2. The hopper did not pay out what it was told. 3. Service the hopper Pg. 21-24. 4. Replace the Hopper wire harness.
<p>FOR TECHNICAL SERVICE OR TO OBTAIN A RETURN AUTHORIZATION NUMBER CALL (888)741-9840</p>	<p><u>ANY REPAIR RETURNED WITHOUT A RETURN AUTH. # WILL BE REFUSED!!</u></p>

PARTS LIST FOR THE AC1000/1001

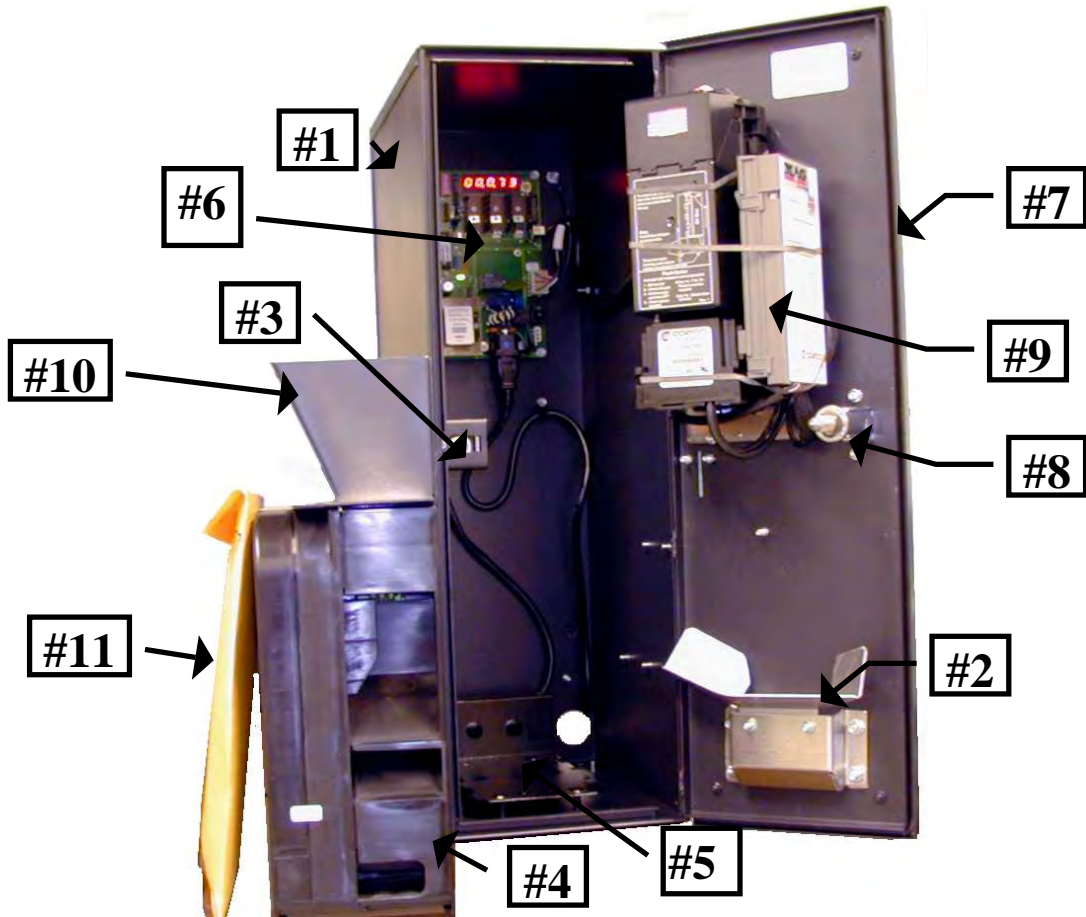

AC1000/1001 PARTS LIST (SHOWN ABOVE)

- | | |
|-----------------------|--------------------------------------------------------|
| 1. AC1010 - | CABINET COMPLETE W/ COIN CUP (#2) & LOCK BRACKET (#3). |
| 2. AC1010-01 - | COIN CUP |
| 3. AC1010-30 - | LOCK BRACKET ASSY. COMPLETE. |
| 4. AC1041 - | COIN CONTROLS MK4 COIN HOPPER. |
| 5. AC1040.3 - | COIN CONTROLS HOPPER PLATE W/ FEMALE PLUG & HARNESS. |
| 6. AC1061 - | MAIN LOGIC BOARD. |
| 7. AC1081 - | FULL FACE LEXAN FRONT. |
| 8. AC5080 - | SCREW-IN T-HANDLE. (No Lock & Key) |
| 9. AC9000 - | COINCO MAG50 (PRO) BILL VALIDATOR. |
| 10. AC1042 - | HOPPER EXTENSION 1200 MORE COINS (1 Per machine ONLY!) |
| 11. 1900 - | MANUAL KIT FOR THE AC1000/1001 |

AC1000/1001 OPTIONAL PARTS LIST (ITEMS NOT SHOWN.)

- AC1043.1** - 650 BILL STACKER
- AC1070** - BASE (PEDESTAL)
- AC1075** - HEADER
- AC1091** - TILT ALARM ONLY
- AC1093** - LOCK AND KEY
- 1093-01** - Extra Keys (Need the ACC key number)
- AC9003** - MARS AE2601-U5E BILL VALIDATOR

- #1 - 1041-24-01
Motor
- #2 - 1041-24-02
Motor Side Cover
- #3 - 1041-24-03
Center Plate
- #4 - 1041-24-04
End Plate
- #5A - 1041-24-05
Coin Optic Board
- #5B - 1041-24-06
Optic ribbon cable
- #6 - 1041-24-07
Red track plates (16 per belt)
- #7 - 1041-24-08
Logic board wire harness
- #8 - 1040-24-113
Male 12 pin connector
- #9 - 1040-24-112
Female 12 pin connector
- #10 - 1041-24-10
Idler gear
- #11 - 1041-24-11
Gear Box
- #12 - 1041-24-12
Gear Shaft
- #13 - 1041-24-13
Black plastic Gear #1
- #14 - 1041-24-14
Gear #3 & 4, metal
- #15 - 1041-24-15
Output gear, metal/plastic
- #16 - 1041-24-16
Idler Gear #4, thick metal

- #17 - 1040-24-22
Blanking Plate
- #18 - 1040-24-25
Fixing screw

- #19 - 1041-24-19
Cam Shaft
1041-24-20
Cam shaft bearing

- #20 - 1041-24-21
Cam Agitator
- #21 - 1041-24-22
Agitator

- #22 - 1040-24-291
Low level contact plate
- #23 - 1041-27-373
Mark IV PC logic board

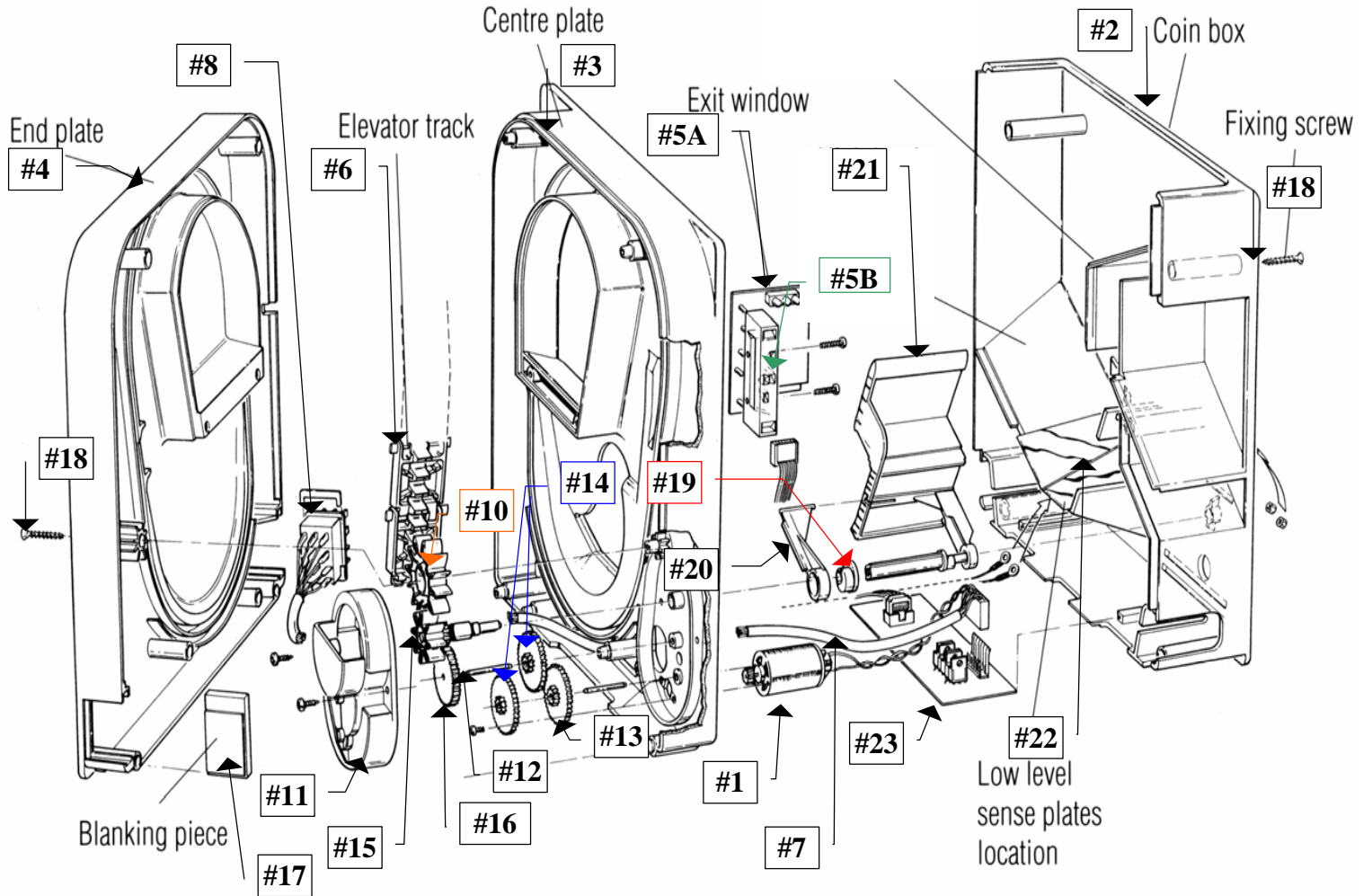

COINCO PARTS LIST

MOUNTING ASSEMBLY PARTS BREAKDOWN

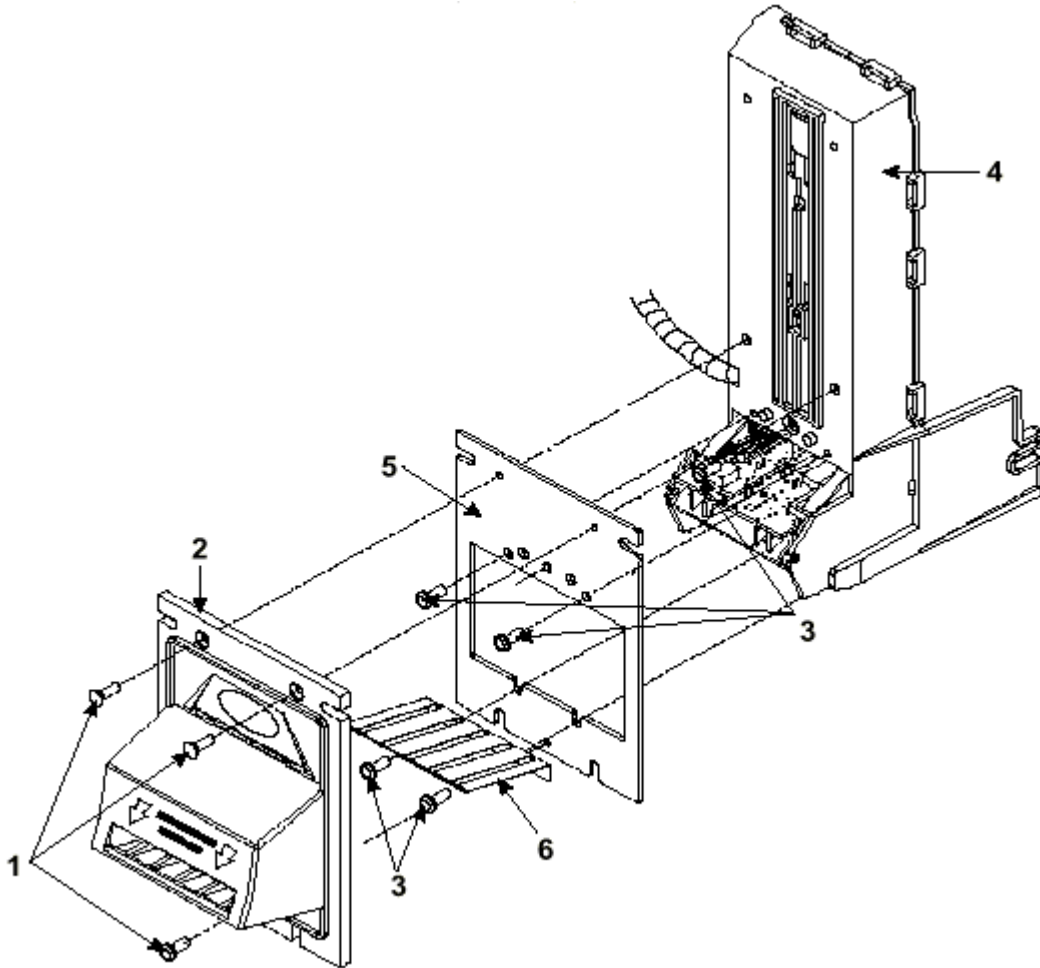

<u>PICTURE #</u>	<u>PART #</u>	<u>DESCRIPTION</u>
#1	MP90-1-1	Machine Screw
#2	MP90-1-2	"Snack Mask" Black Plastic
#3	MP90-1-3	Machine Screw
#4	MP90-1-4	Main Frame, Plastic
#5	MP91-1-5	Mask Gold Mounting Bracket
#6	MP90-1-6	Bill grounding spring
#7	MP91-1-7	Machine Nut

COINCO PARTS BREAKDOWN

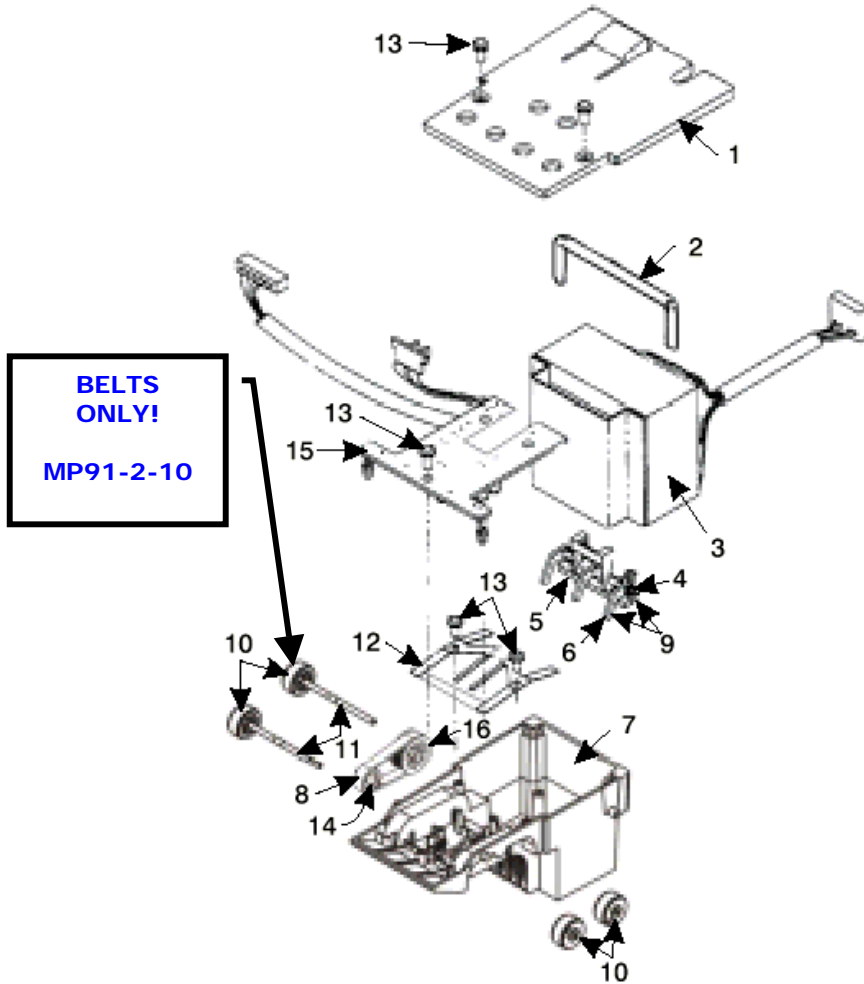

<u>PICTURE #</u>	<u>PART #</u>	<u>DESCRIPTION</u>
#1	MP90-2-1	Bottom Lower Housing Cover
#2	MP90-2-2	Transformer holding hose
#3	MP90-2-3	120VAC Transformer
#4	MP90-2-4	Lower Spring, Anti-Cheat Lever
#5	MP91-2-5	Lower Mounting, Anti-Cheat Lever
#6	MP90-2-6	Lower Anti-Cheat Lever
#7	MP90-2-7	Lower Housing Assembly, Complete
#8	MP90-2-8	Belt, Center
#9	MP90-2-9	Lower Anti-Cheat Assembly, Complete
#10	MP90-2-10	Plastic Wheels & Rubber Belts
#10	MP91-2-10	Rubber Belts ONLY (Each)
#11	MP90-1-11	Shaft, Drive
#12	MP90-2-12	Spring, MAG
#13	MP90-2-13	Screw, #4, Plastic
#14	MP90-2-14	Roller, Idler
#15	MP91-2-15	Sensor Board, Lower
#16	MP91-2-16	Pulley & Hub Assembly, Complete

COINCO PARTS BREAKDOWN

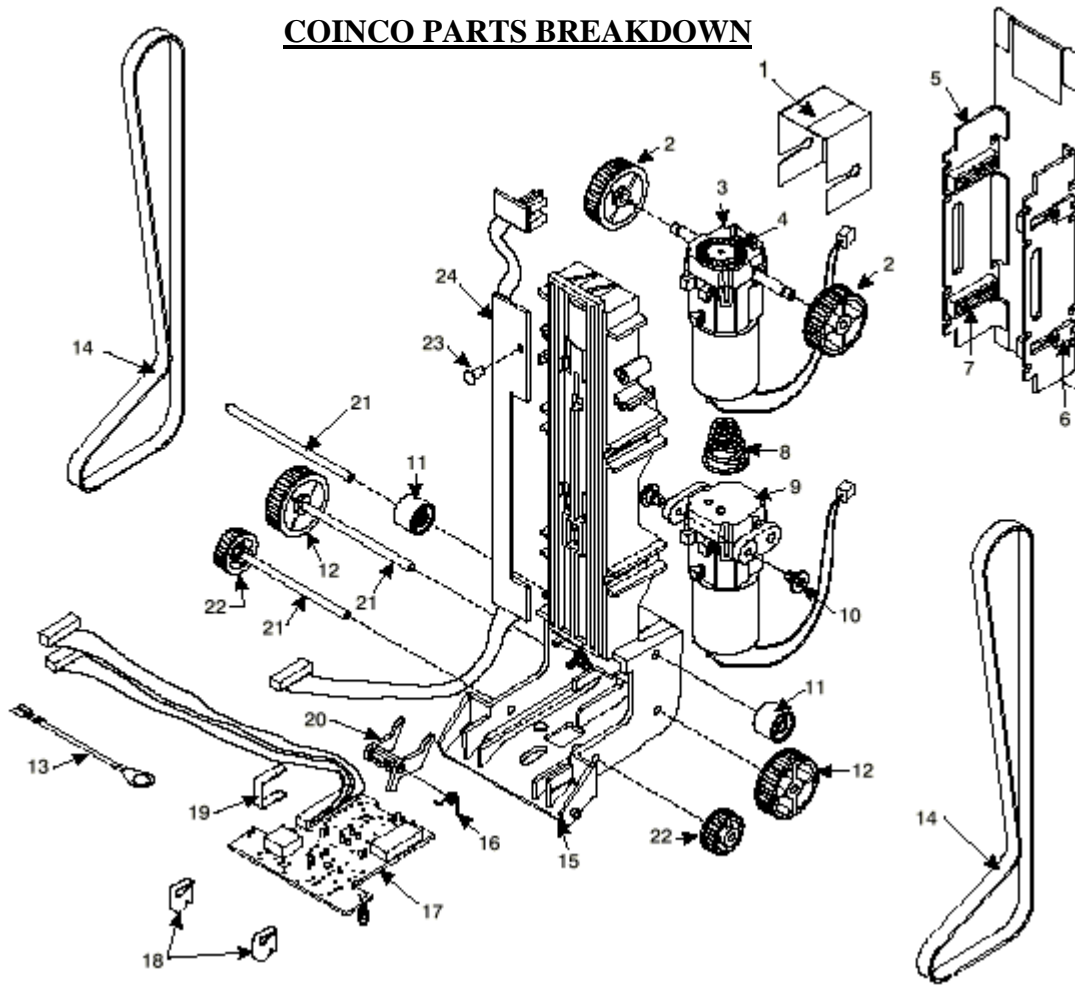

<u>PICTURE #</u>	<u>PART #</u>	<u>DESCRIPTION</u>
#1	MP90-3-1	Dust Cover
#2	MP90-3-2	Upper Transport & Hub Assembly, Complete
#3	MP91-3-3	Motor, Transport & Gear Assembly Complete
#4	MP90-3-4	Wheel, Encoder
#5	MP90-3-5	Stacker, Push-Plate Assembly
#8	MP90-3-8	Spring, Belt Tension
#9	MP90-3-9	Motor, Stacker Assembly Complete
#10	MP90-3-10	Pulley, Idler
#11	MP90-3-11	Lower Transport Pulley & Hub Assembly
#13	MP90-3-13	Belt, Upper Housing
#14	MP90-3-14	Frame, Upper Housing
#15	MP91-3-15	Sensor Board, Upper Housing
#16	MP90-3-16	Upper Board Clip
#17	MP90-3-17	Wire Clip
#18	MP90-3-18	Shaft, Pulley
#19	MP90-3-19	Shaft, Wheel
#21	MP90-3-21	Board, Stacker

COINCO PARTS BREAKDOWN

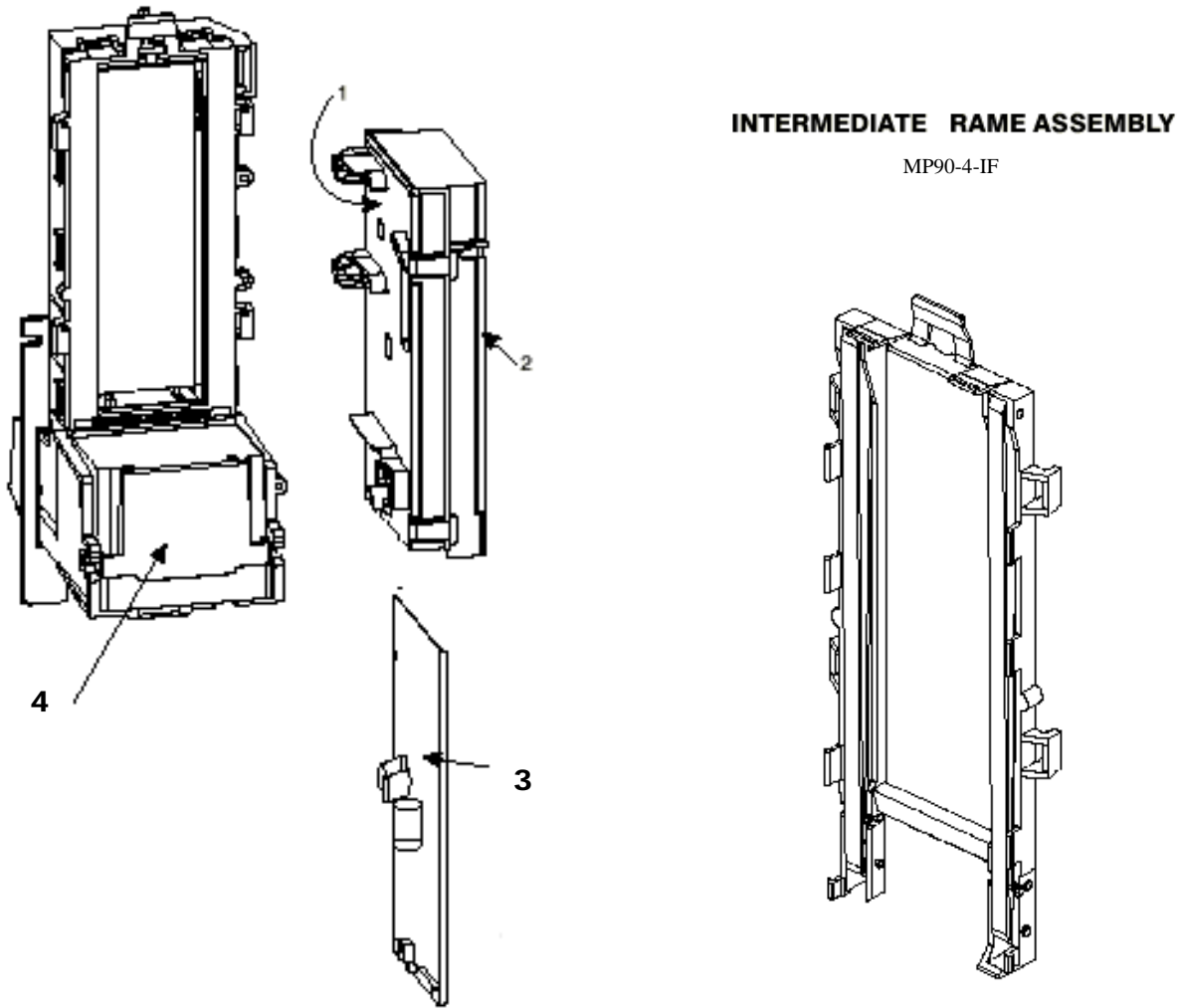

<u>PICTURE #</u>	<u>PART #</u>	<u>DESCRIPTION</u>
#1	MP90-4-1	Lid, Logic board Box
#2	MP91-4-2	Body, Logic board Box
#3	MP90-4-3	Main Logic Board
#4	MP90-4-4	Sticker, Serial Number / Warranty
#5	MP90-4-IF	Intermediate Frame with Bearings

MARS AE2600 SERIES 24VDC PARTS BREAKDOWN

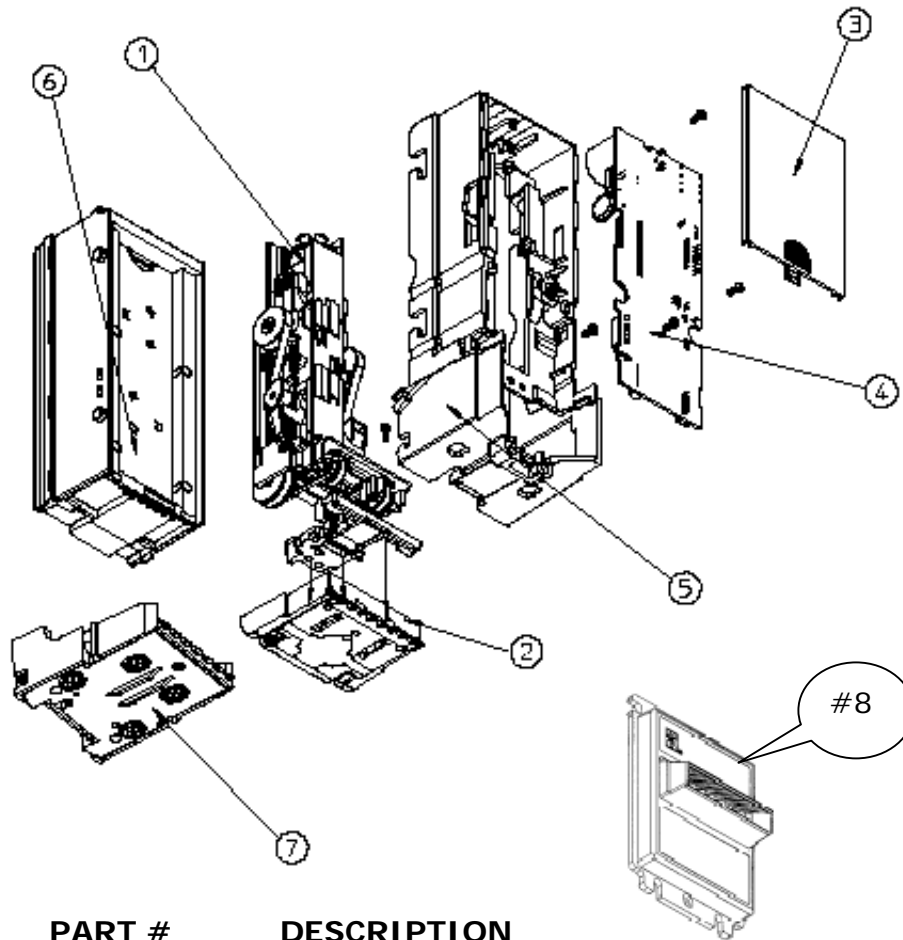

<u>PICTURE #</u>	<u>PART #</u>	<u>DESCRIPTION</u>
#1	AE93-1-1	Stacker/Drive Assembly Kit
#2	AE93-1-2	Sensor Housing Assy, Complete
#3	AE93-1-3	Control Board Cover, Plastic
#4	AE93-1-4	120VAC Logic Board
#5	AE93-1-5	Main Chassis, Plastic
#6	AC1045	500 Stacker
#7	AE93-1-7	LED Housing Assy, Complete
#8	AE93-1-8	Black Front Bezzle, Plastic
#9	AE93-1-9	Metal Bezzle Support Plate (NOT SHOWN)

CONTINUED

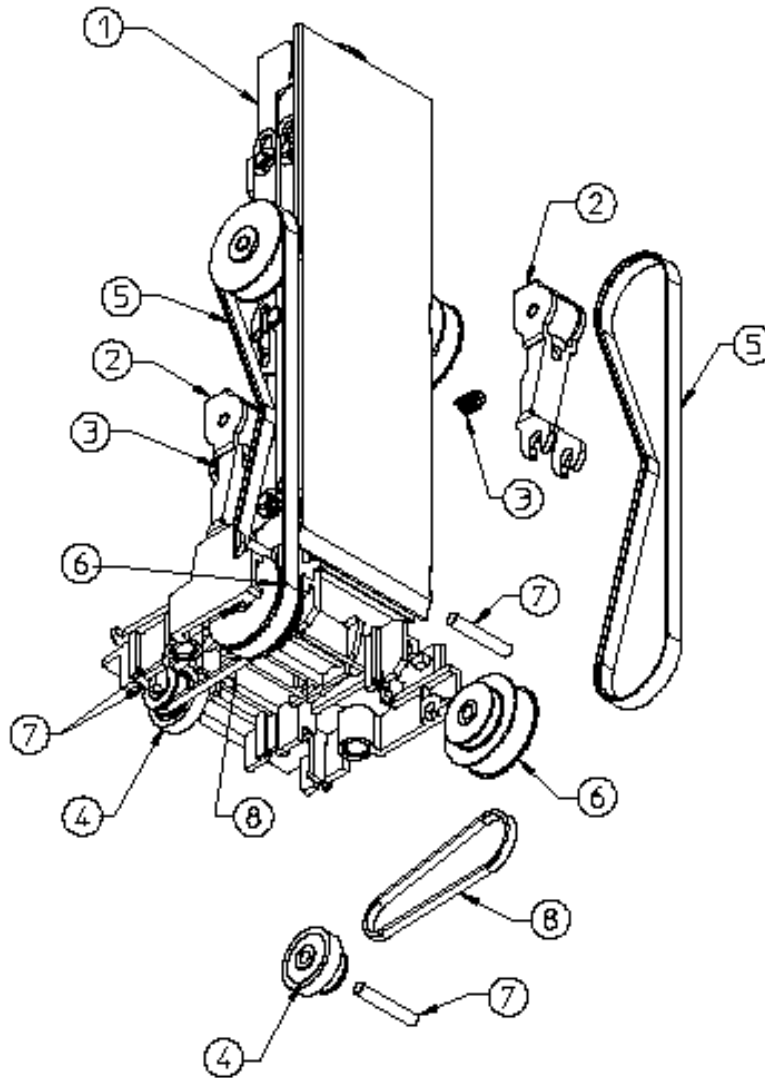

<u>PICTURE #</u>	<u>PART #</u>	<u>DESCRIPTION</u>
#1	AE93-2-1	Gearbox Assy
#2	AE93-2-2	Tension Assy
#3	AE93-2-3	Tension Spring
#4	AE93-2-4	Tire/Wheel Assy
#5	AE93-2-5	Belt, Timing, (1 of 2)-143 Teeth
#6	AE93-2-6	Pulley, Compound
#7	AE93-2-7	Shaft, Pulley
#8	AE93-2-8	Belt, Timing, (1 of 2)-56 Teeth

CONTINUED

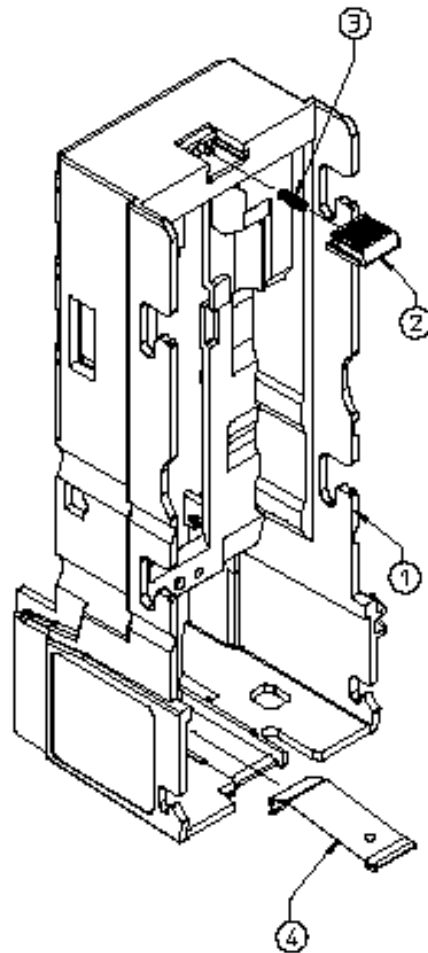

<u>PICTURE #</u>	<u>PART #</u>	<u>DESCRIPTION</u>
#1	AE93-1-5	Main Chassis, Plastic
#2	AE93-3-2	Stacker Latch, Blue
#3	AE93-3-3	Spring, Stacker Latch
#4	AE93-3-3	Lower Housing Lift Spring