

# FLOOR SEGMENT SILENT ROOM XL

Assembly scheme

Aufbauanleitung

Schéma d'assemblage

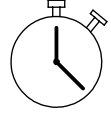
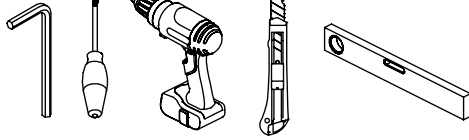
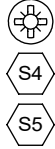
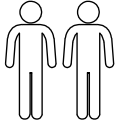

02:00

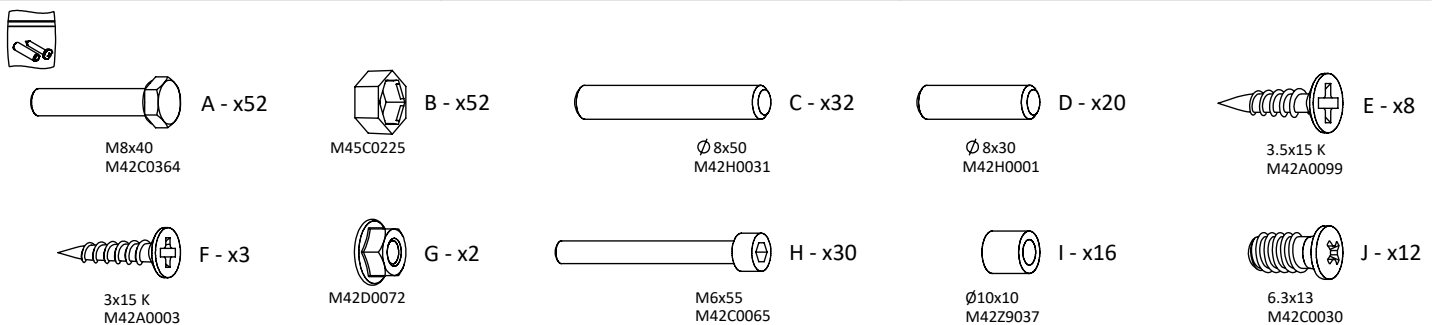
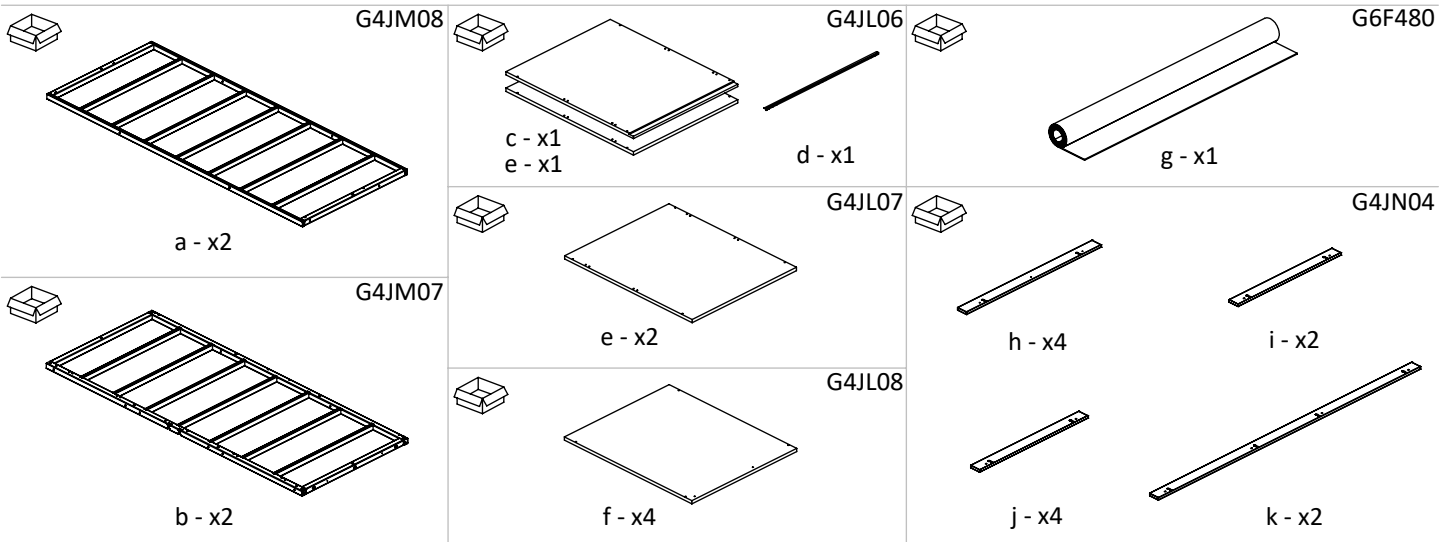
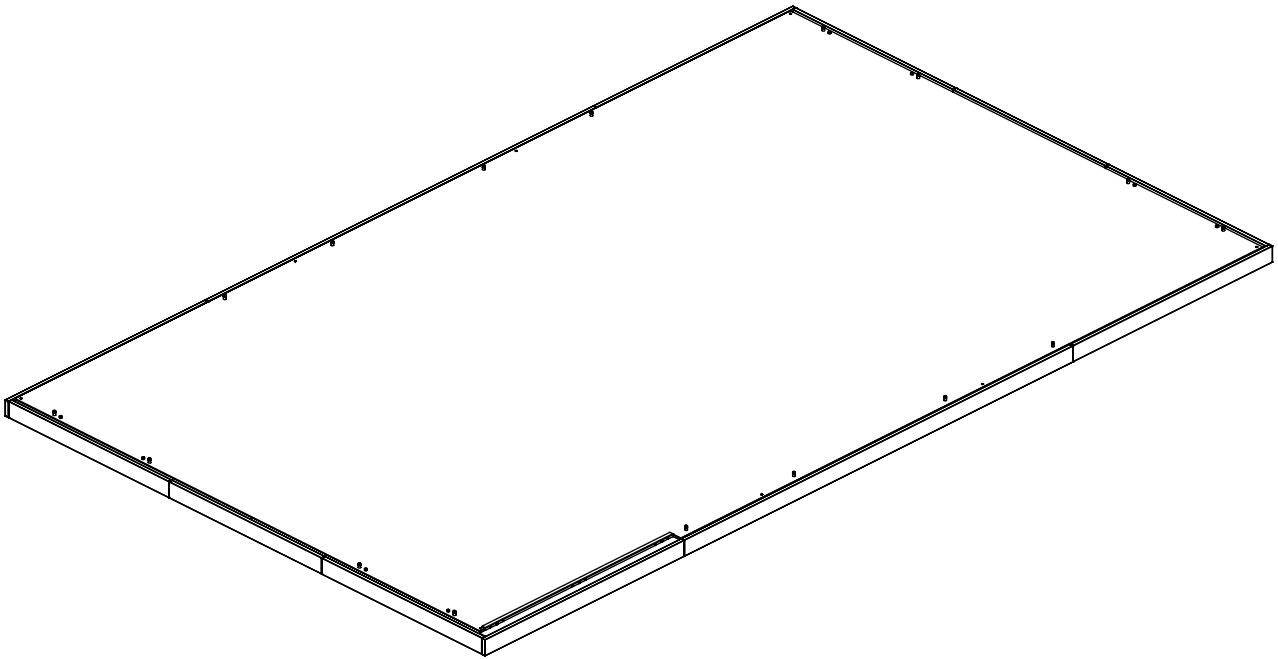

1

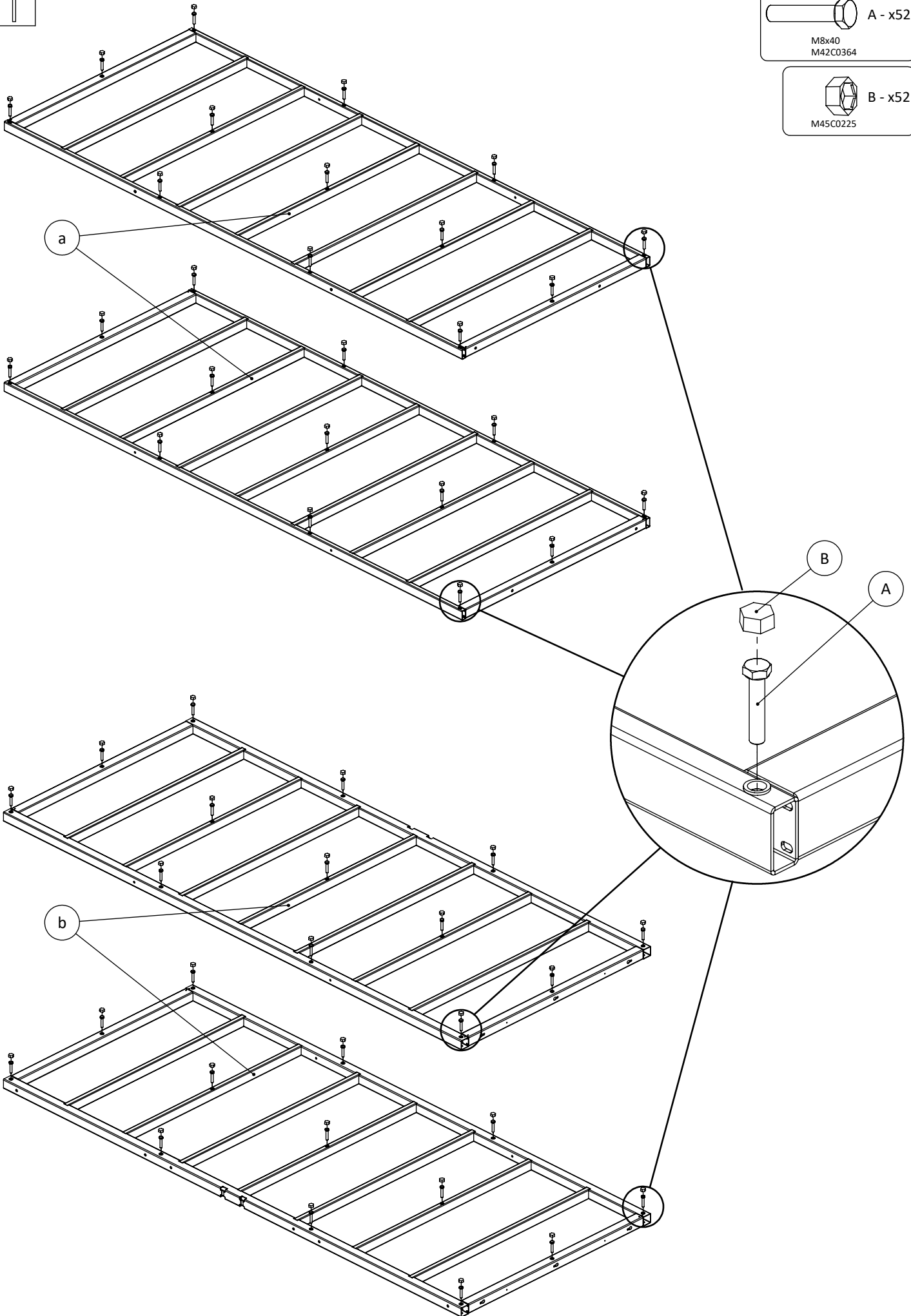
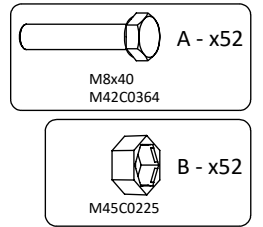

2

Do not tighten the frame bolts yet

Ziehen Sie die Rahmenschrauben noch nicht fest

Ne serrez pas encore les boulons du cadre

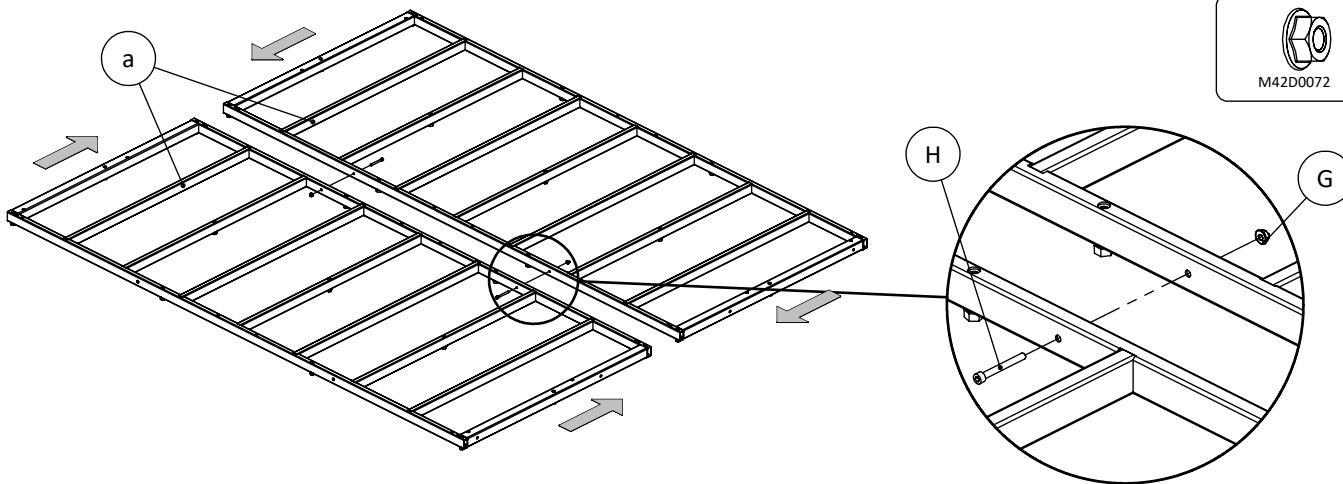
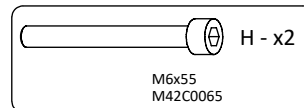

3

Do not tighten the frame bolts yet

Ziehen Sie die Rahmenschrauben noch nicht fest

Ne serrez pas encore les boulons du cadre

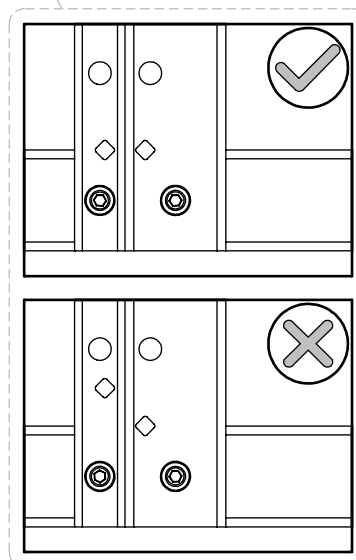
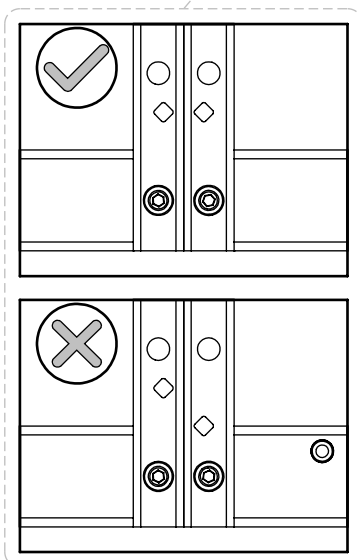
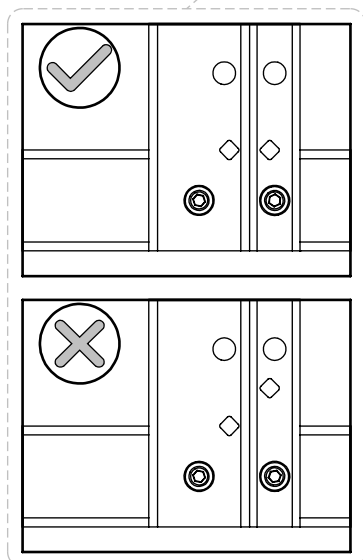
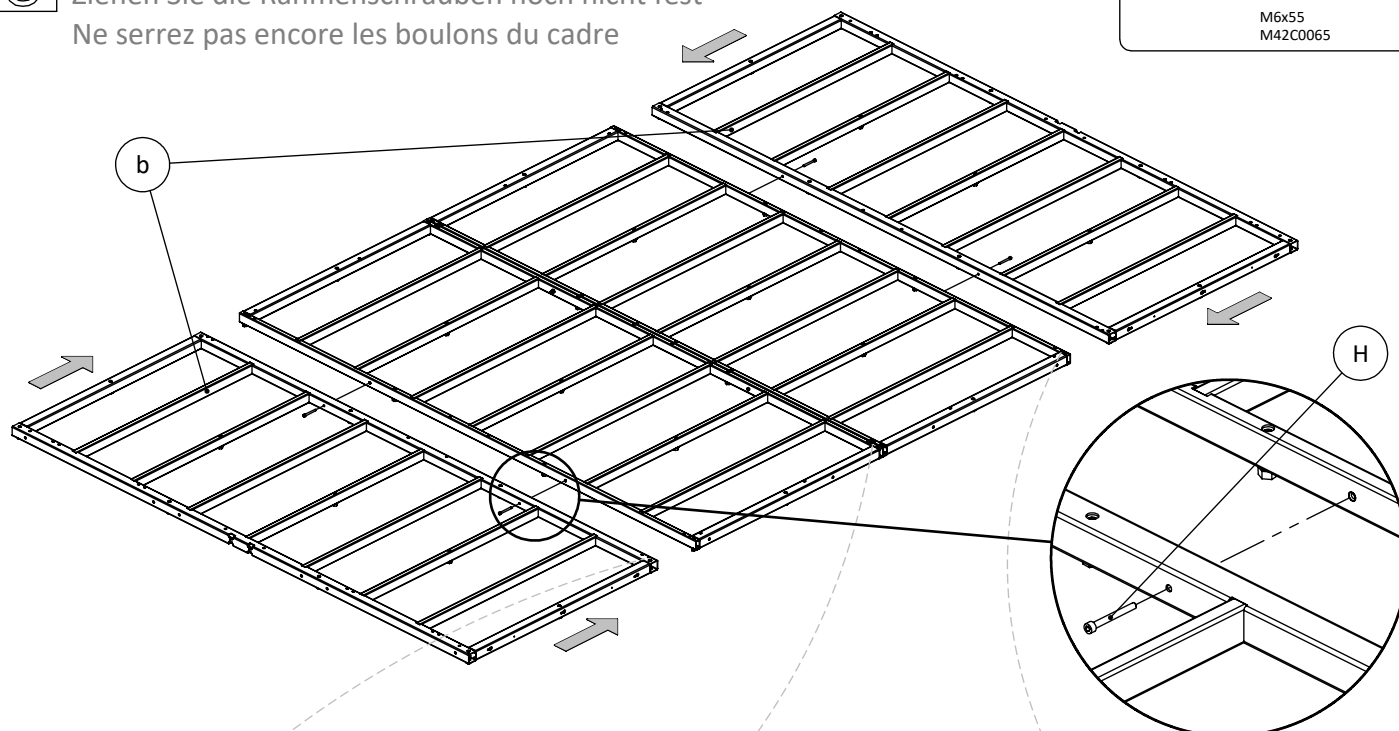
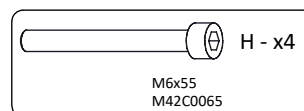

- 4** Level the frame by adjusting the supports. All supports should be in contact with the surface.  
Nivellieren Sie den Rahmen, indem Sie die Stützen anpassen.  
Alle Stützen sollten Kontakt mit der Oberfläche haben.  
Nivelez le cadre en ajustant les supports.  
Tous les supports doivent être en contact avec la surface.

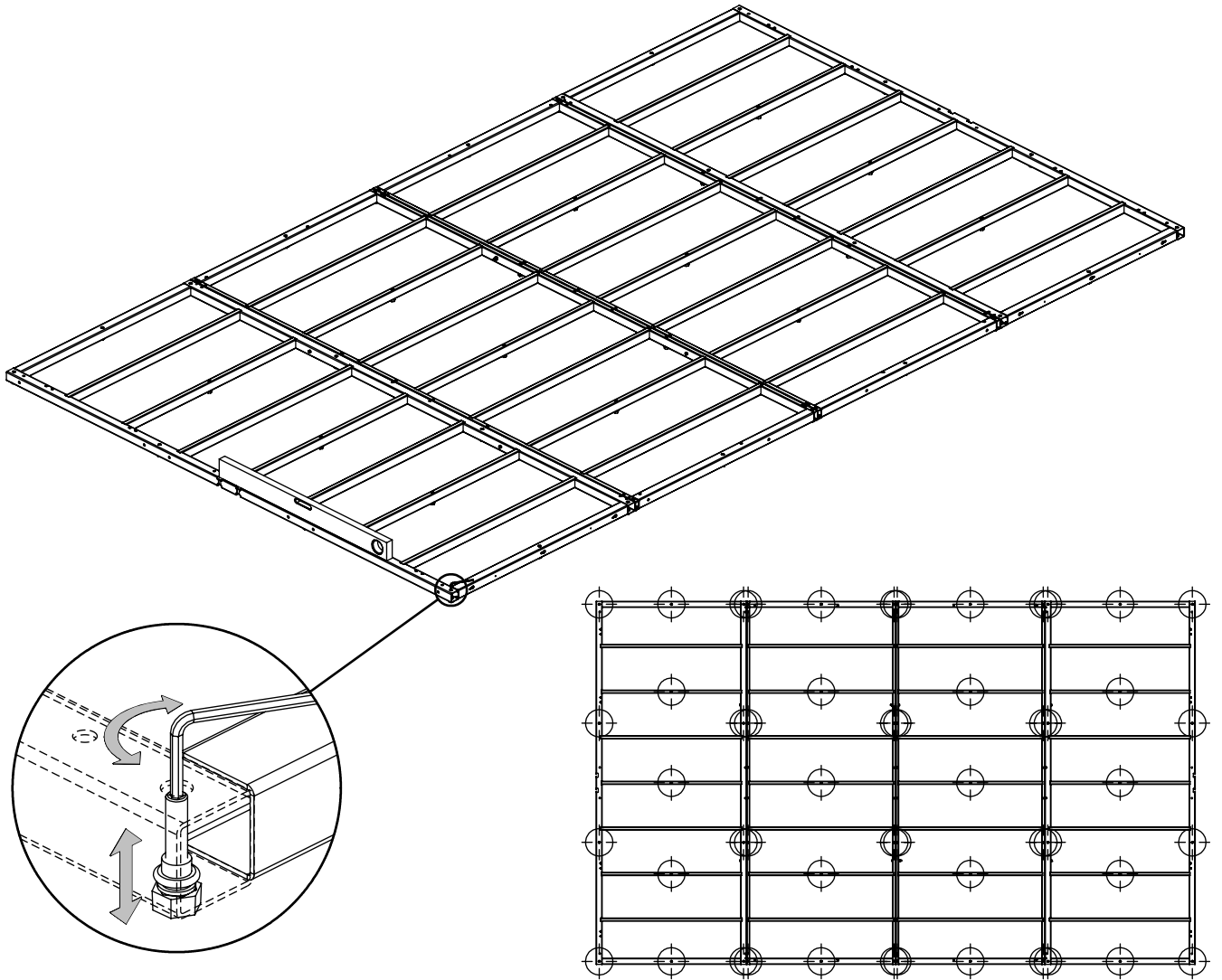

- 5** Tighten the frame bolts  
Ziehen Sie die Rahmenschrauben fest  
Serrer les boulons du cadre

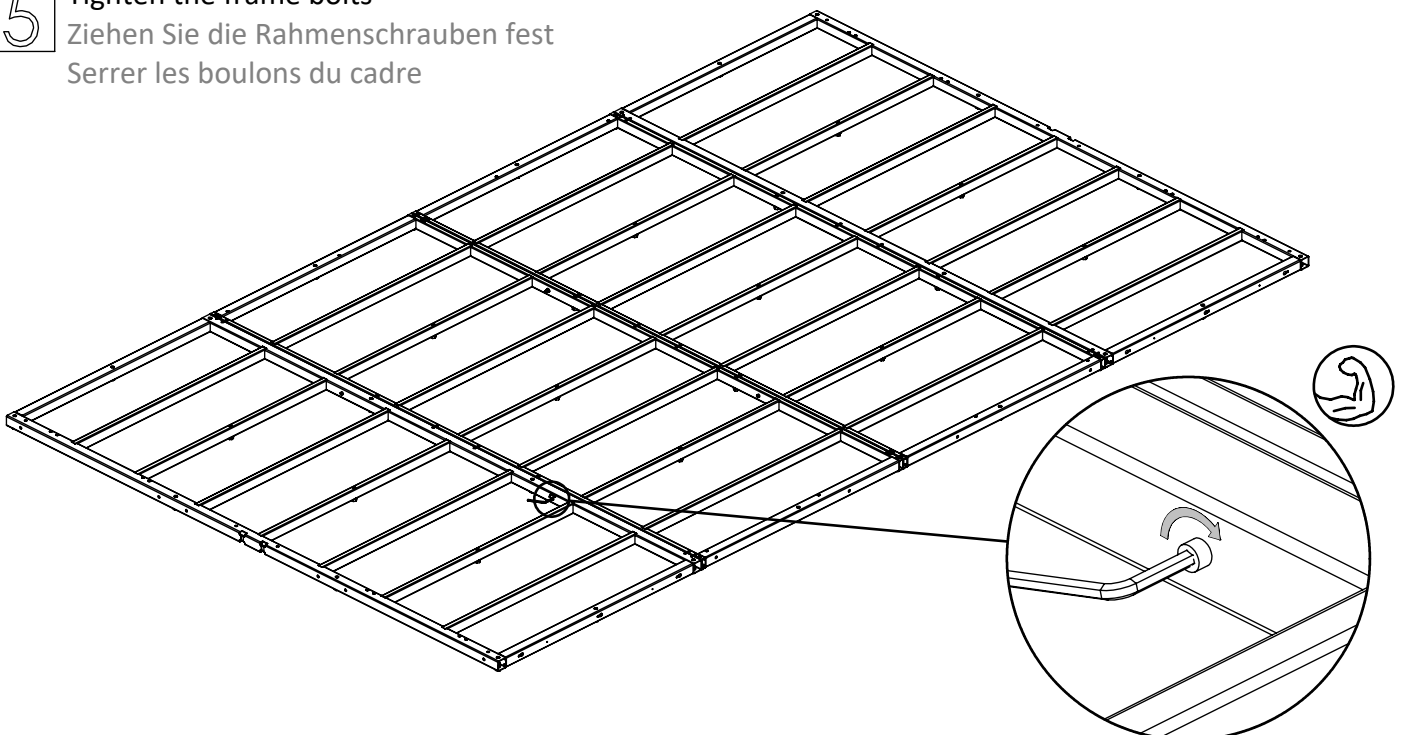

6

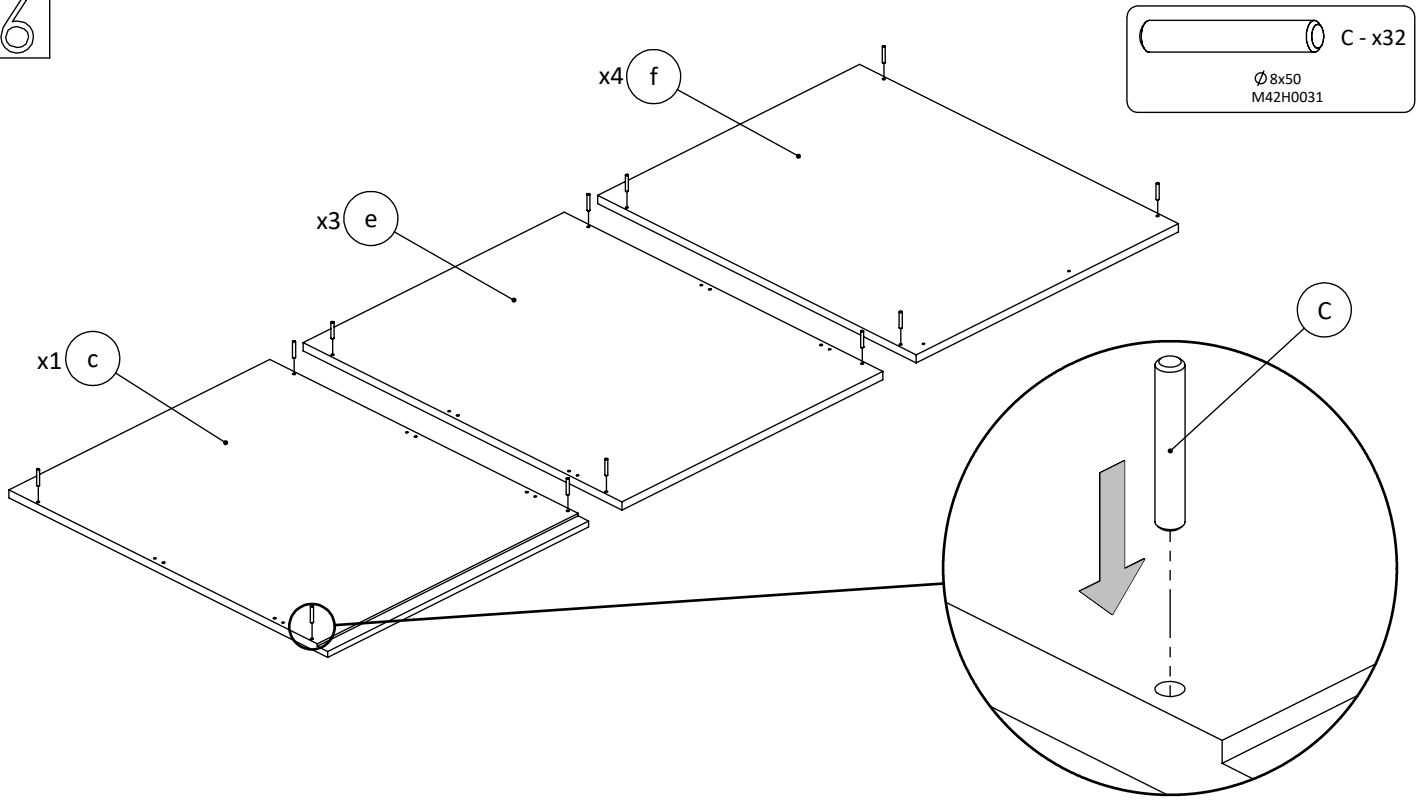

7

**Assemble the floor panel for the door in the selected position**  
Montieren Sie die Bodenplatte für die Tür in der ausgewählten Position  
Assemblez le panneau de plancher de la porte dans la position choisie

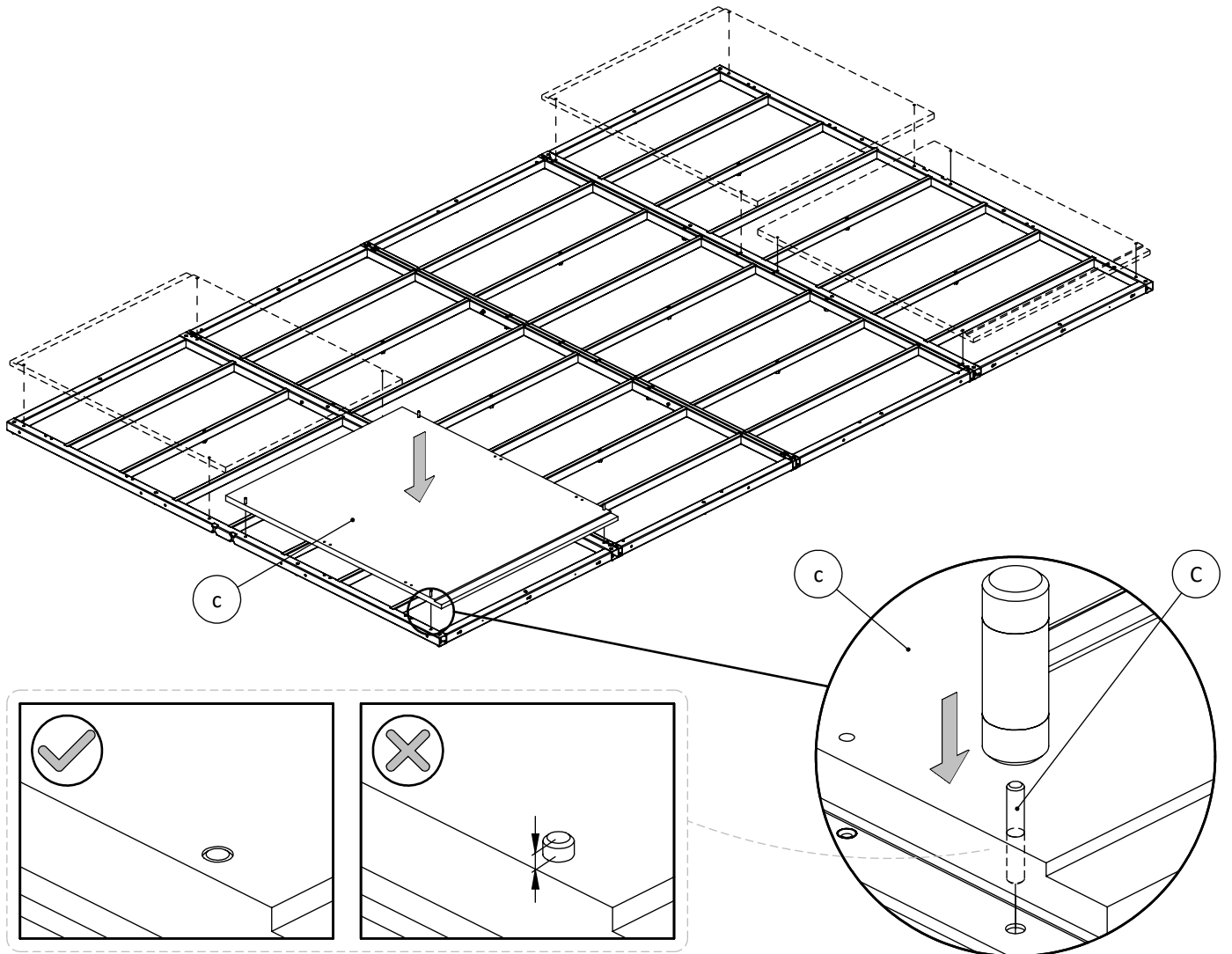



The holes of the floor panels must align with the threaded holes in the outer parts of the frame

Die Bohrungen der Bodenplatten müssen mit den Gewindebohrungen in den Außenteilen des Rahmens fluchten

Les trous des panneaux de plancher doivent être alignés avec les trous filetés dans les parties extérieures du cadre

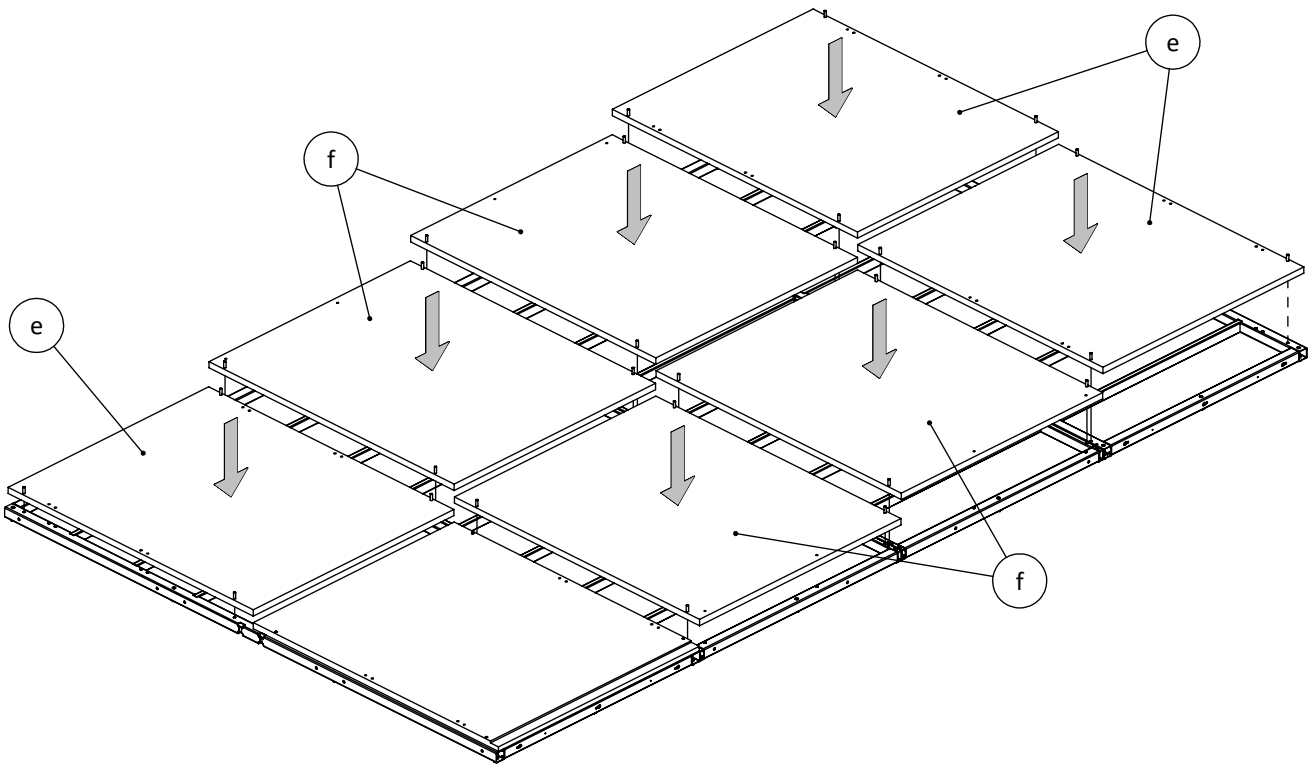

Ensure that the entire floor is leveled and the panels are secured to the frame at the same height

Stellen Sie sicher, dass der gesamte Boden nivelliert ist und die Paneele auf gleicher Höhe am Rahmen befestigt sind

Assurez-vous que tout le sol est de niveau et que les panneaux sont fixés au cadre à la même hauteur

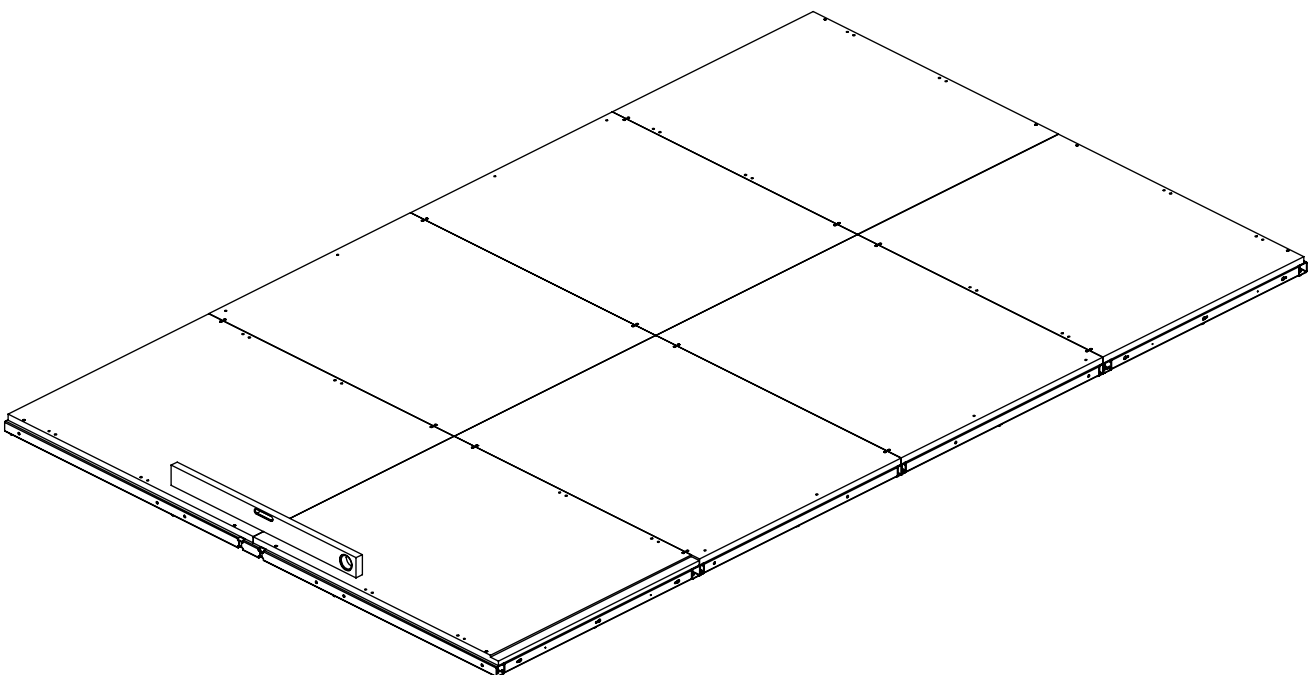

9

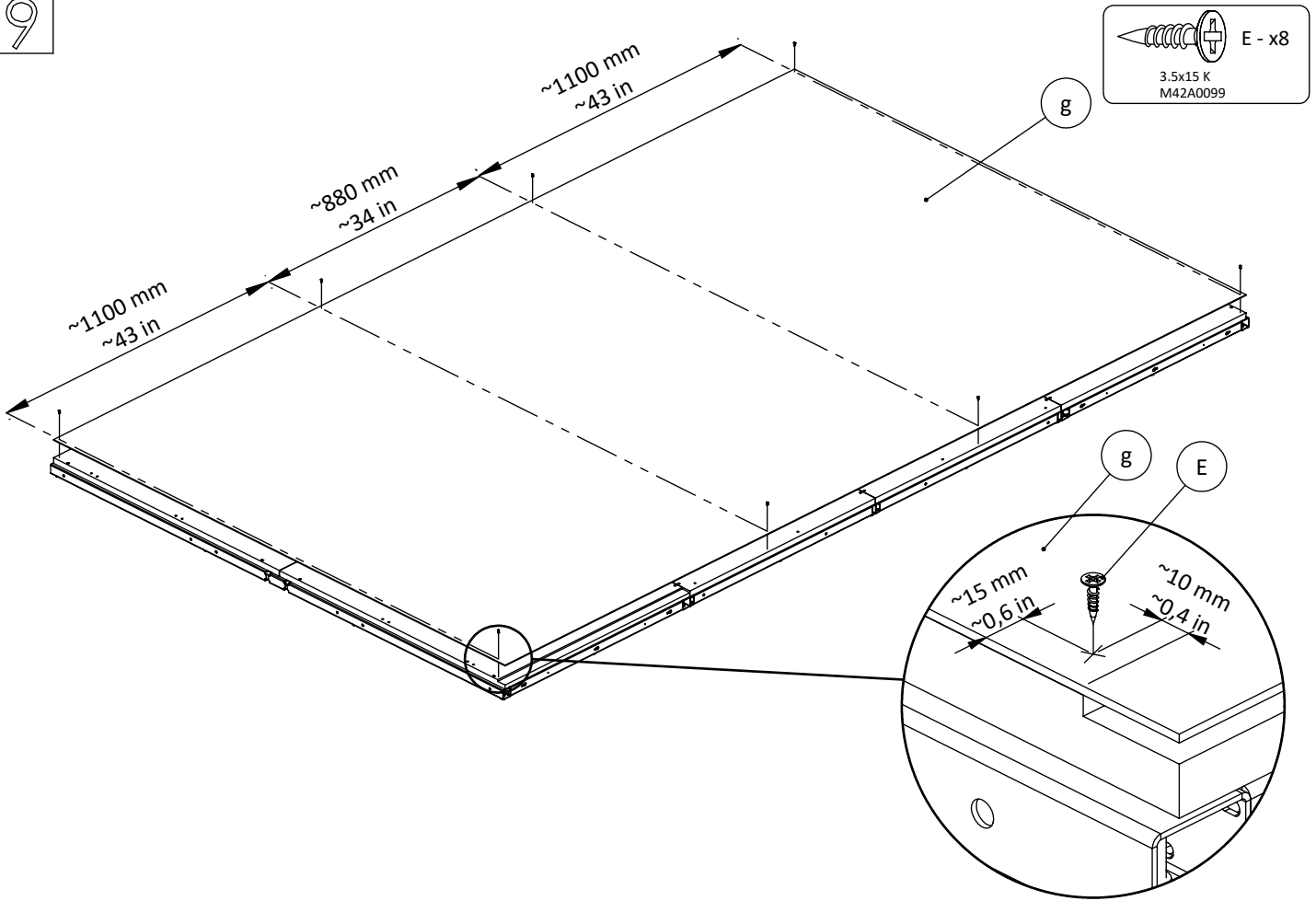

10

Carefully cut the carpet along the edges of the door cutout in the floor

Schneiden Sie den Teppich vorsichtig entlang der Kanten des Türausschnitts im Boden

Coupez soigneusement le tapis le long des bords de la découpe de la porte dans le sol

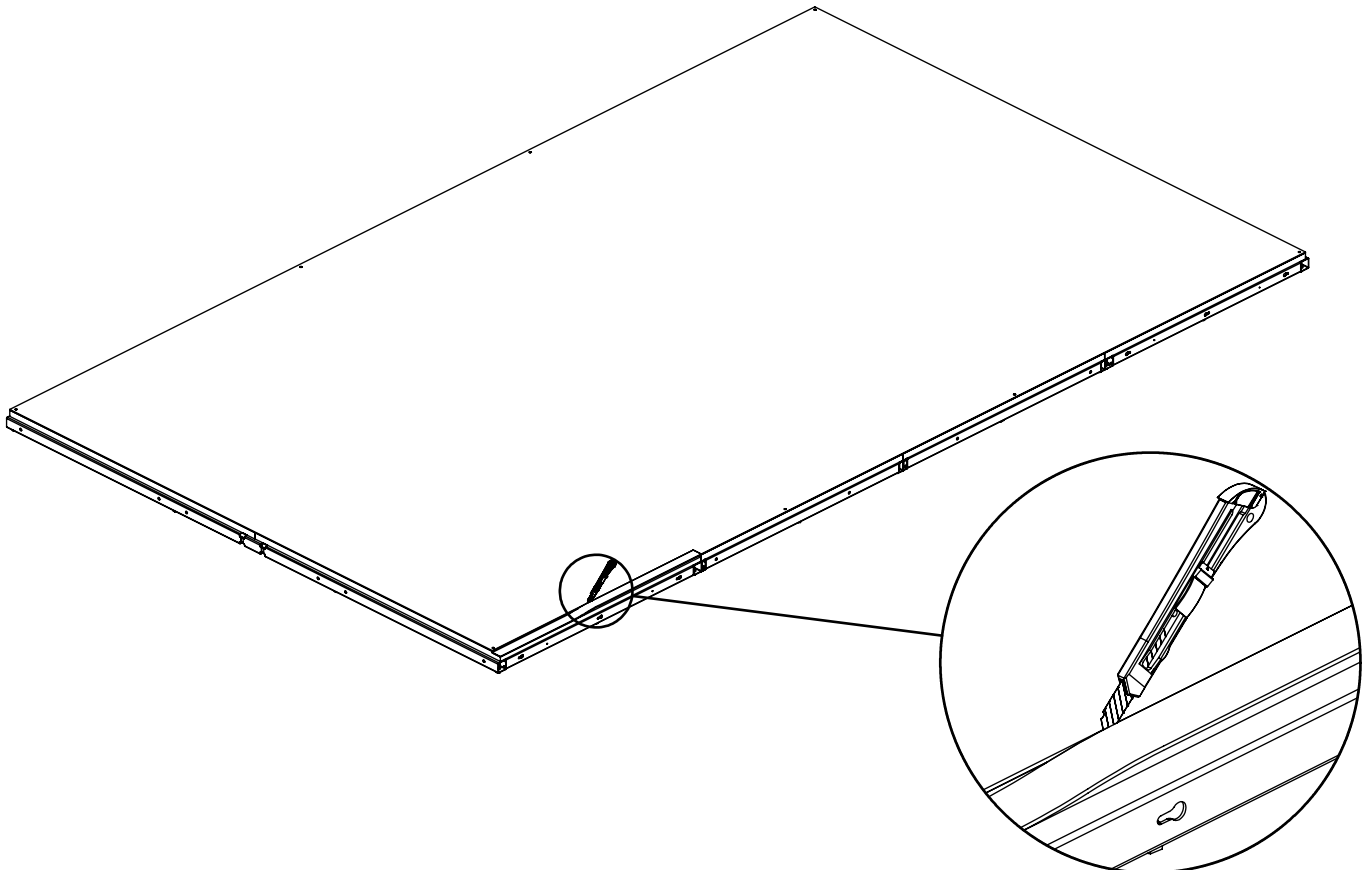

11

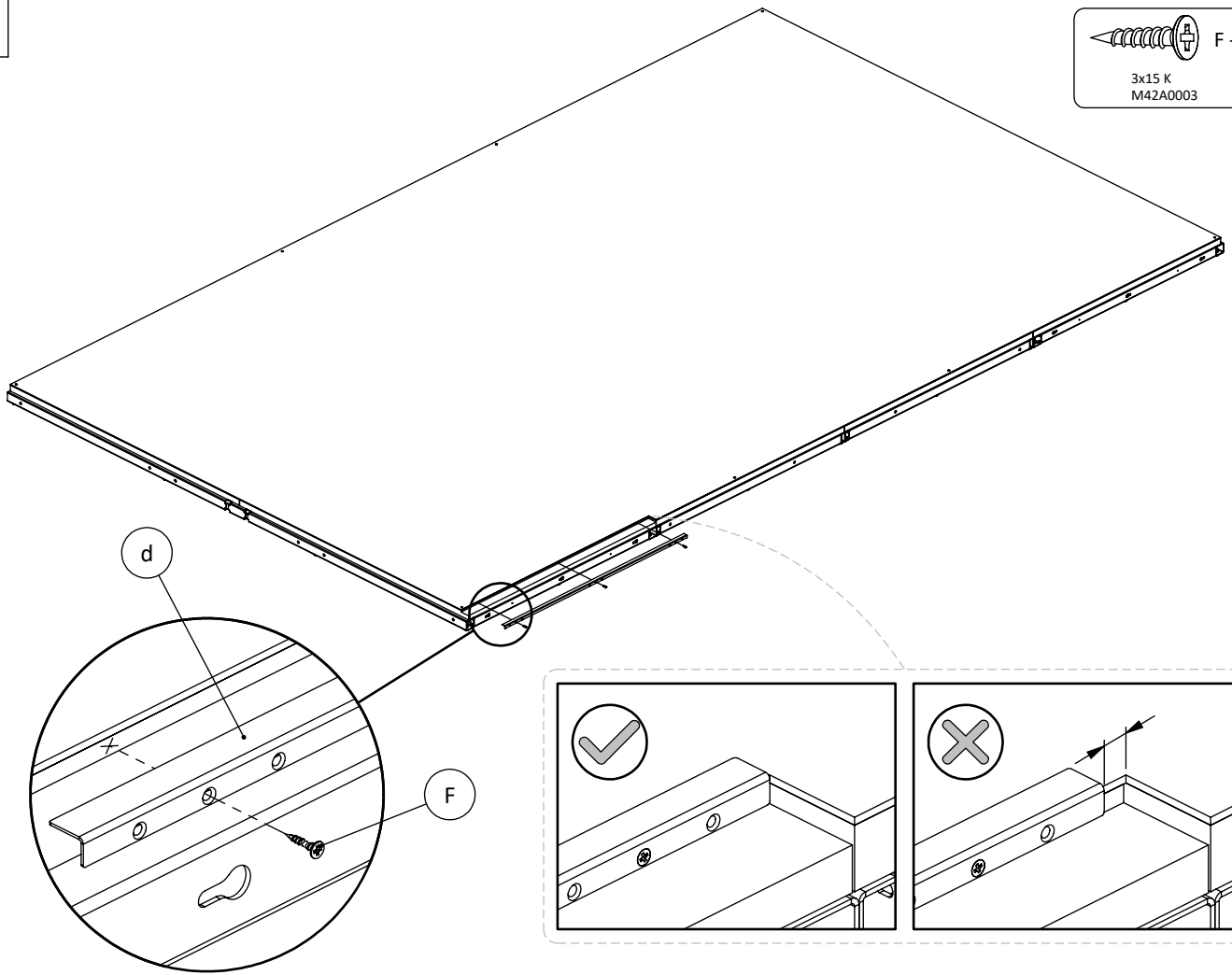
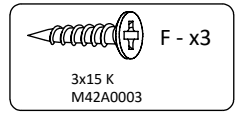

12

Cut the carpet according to the holes in the floor  
Schneiden Sie den Teppich entsprechend den Löchern im Boden zu  
Coupez le tapis en fonction des trous dans le sol

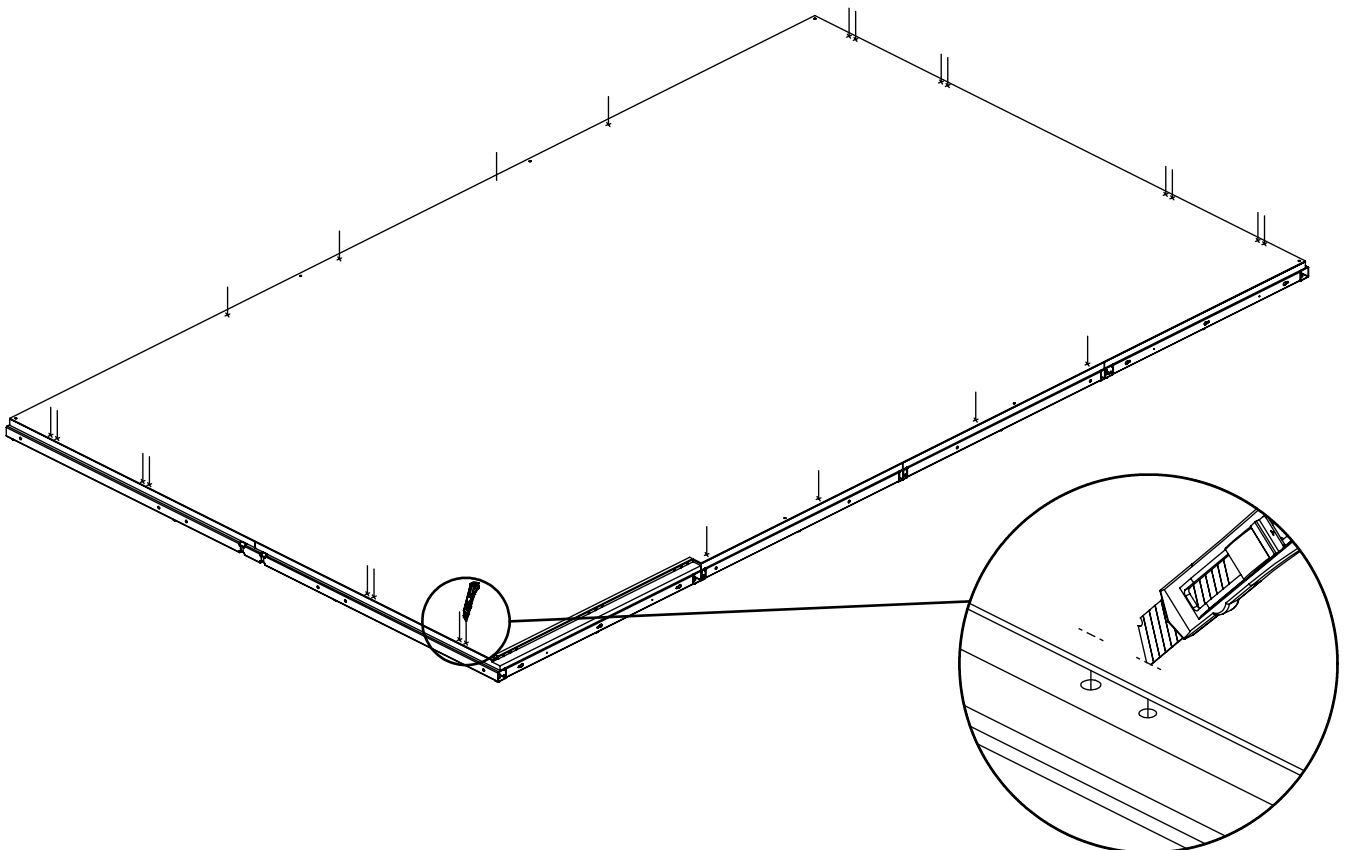



13

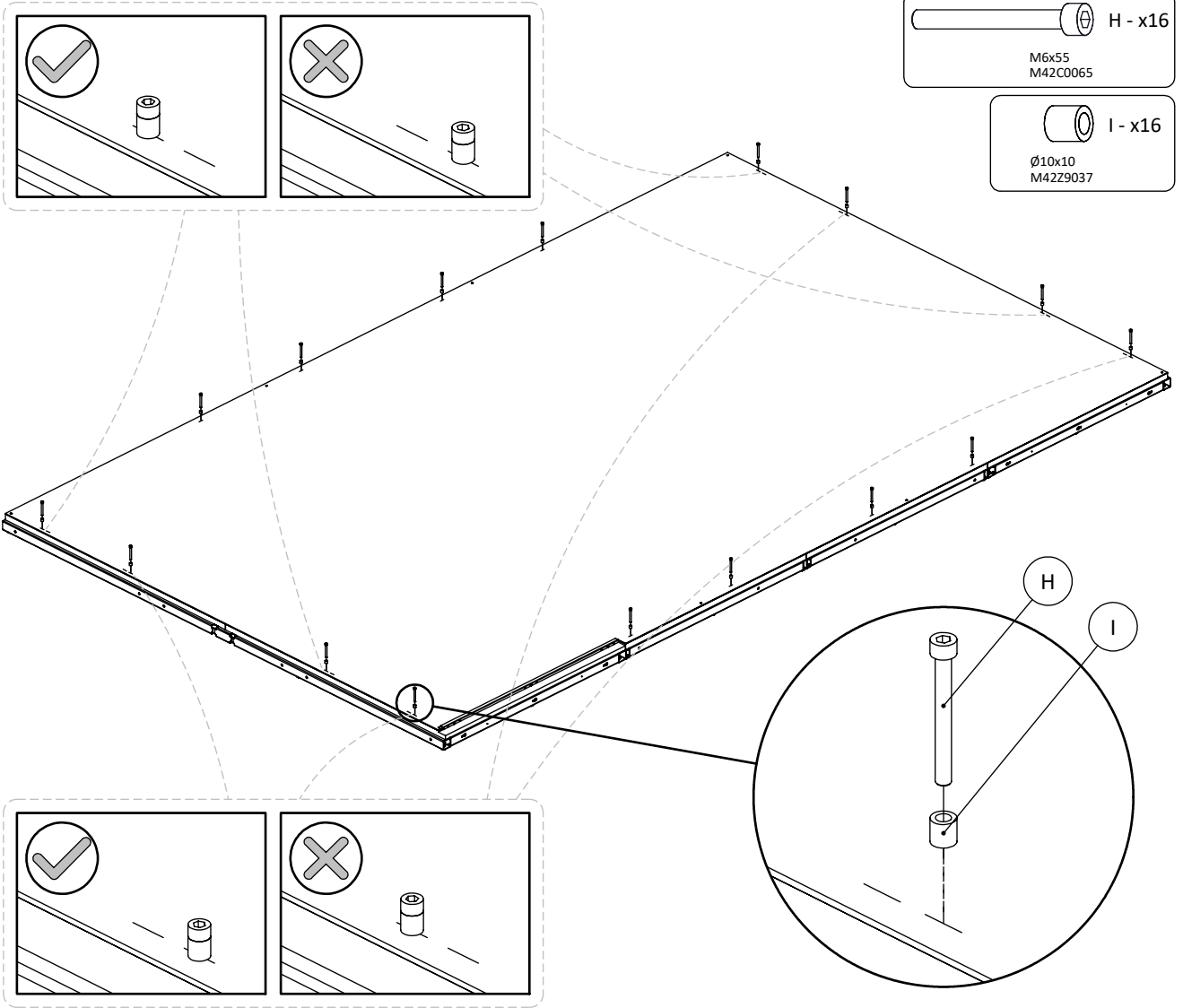

14

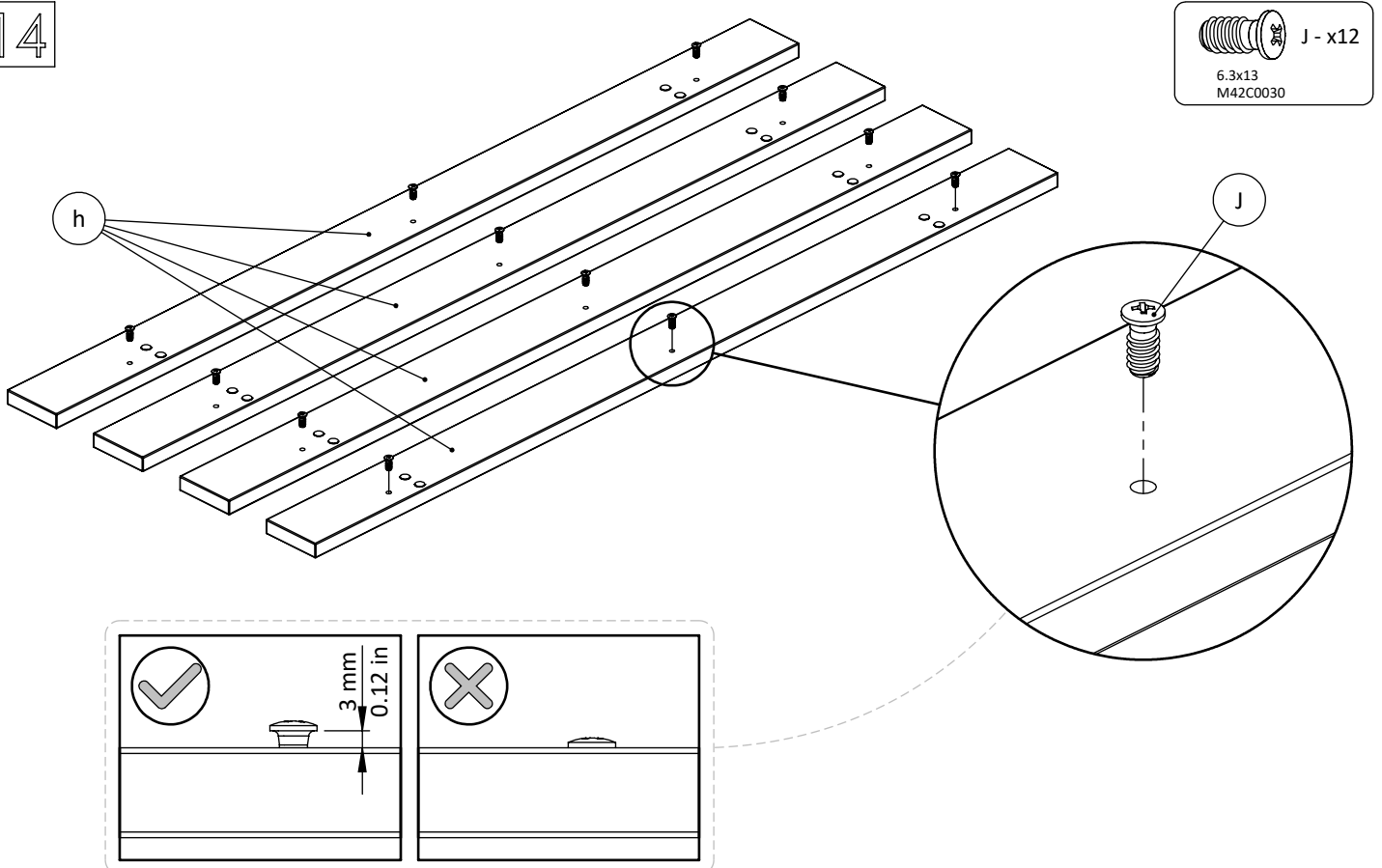

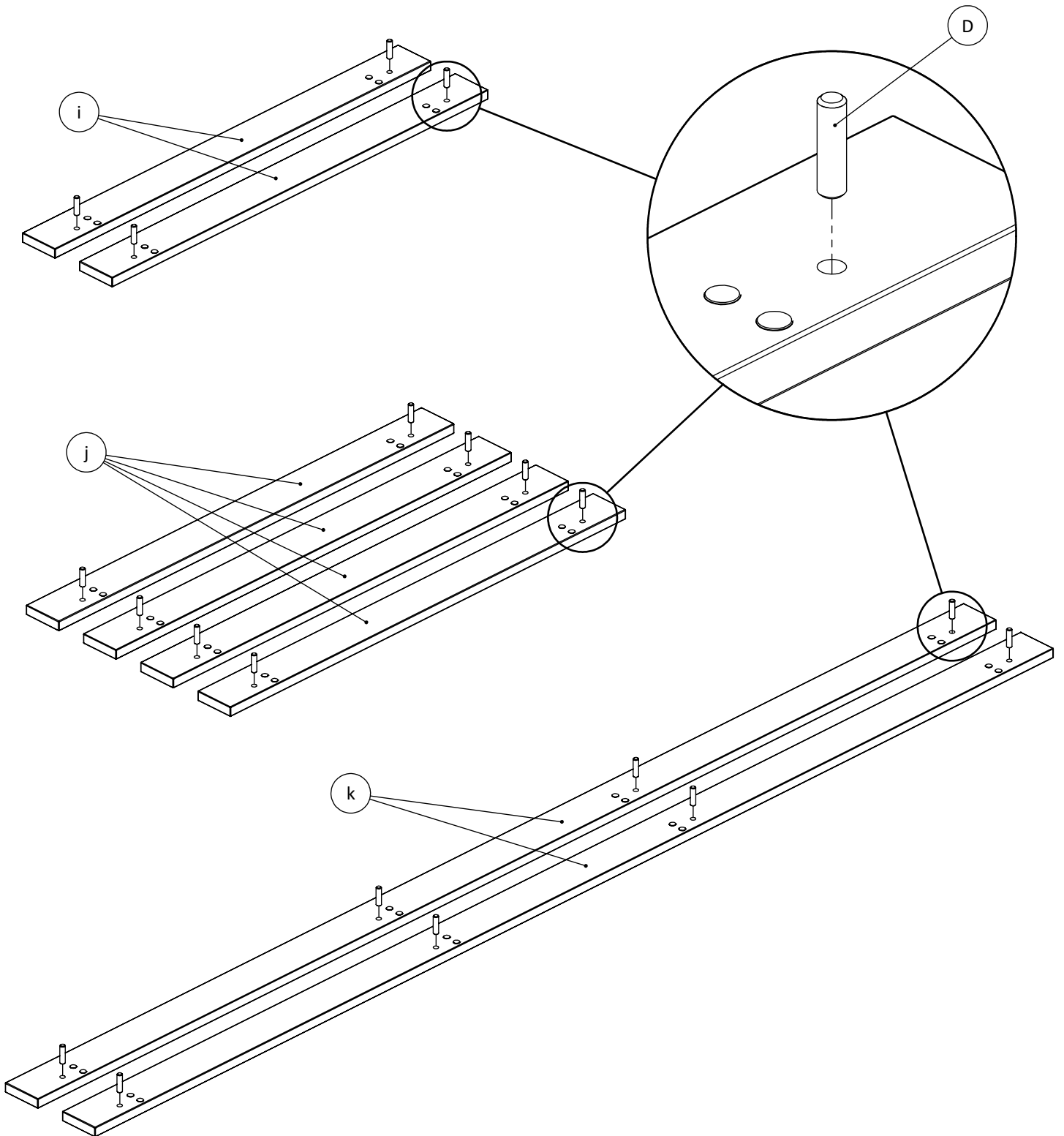
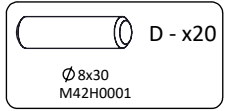

Put aside the pre-assembled baseboards and leftover fasteners for later use  
 Legen Sie die vormontierten Fußleisten und übrig gebliebenen Befestigungselemente zur späteren Verwendung beiseite  
 Mettez de côté les plinthes pré-assemblées et les restes de fixations pour une utilisation ultérieure

