

Intruder™

Weigh with confidence

WEIGH MASTER

WM10/WM25/WM45 On-Site Scale

Operators Guide



Safety



Failure to heed may result in minor or moderate injury.

DO NOT operate or work on scale unless you have read and understand this manual.

DO NOT use for purposes other than weighing.

DO NOT leave loads unattended.

DO NOT Overload - it can damage the scale and will render the warranty null and void.

Cleaning



Important

- Always turn scale off before cleaning.
- Alcohol based wipes when cleaning the scale are recommended.
- **DO NOT** spray with or submerge into water when cleaning.
- Refrain from using corrosive liquids or high pressure washers.
- Improper cleaning will render the warranty null and void.

Inserting/Replacing Battery

When **Lo** appears on display, replace batteries with two 1.5V AA batteries.

1. Remove the battery cover located on back of scale.
2. Remove batteries and dispose of properly.
3. Install new AA batteries according to the diagram in the battery cavity.
4. Replace battery cover securely.

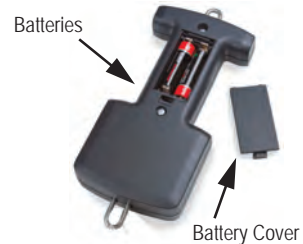

Error Messages

Error	Action	Display
Low Battery	Replace the batteries	Lo
Over Load Total load exceeds the maximum capacity	Remove weight from the scale immediately.	Err
Over Zero Zero count is higher than the setting range.	Scale turns off it status continues 30 secs or longer.	
Below Zero Zero count is below the setting range.	Scale turns off if status continues 30 seconds or longer.	ErrL
EEPROM error	Call for service	ErrE

Table 1. Error Messages

Limited Warranty

All systems and components are warranted against defects in materials and workmanship for one year. For further information see www.intruderinc.com.

Display and Button Functions

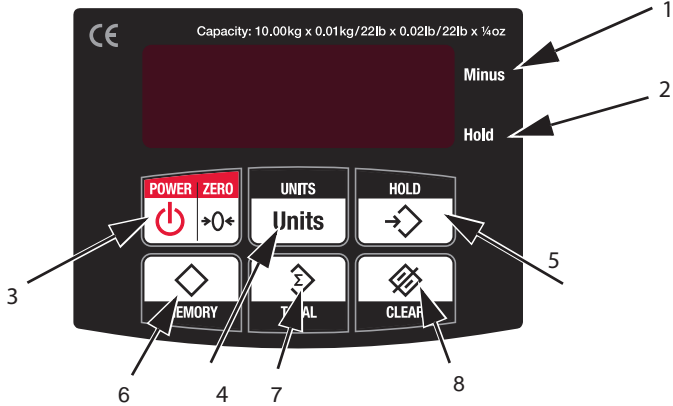



Key	Item	Description
1	Minus	Signifies a negative weight.
2	Hold	Signifies the weight is held.
3	Power/ Zero	Press to turn scale on.
		Press to reset scale to zero.
		Press and hold to run scale off.
4	Units	Select kilograms, pounds or pounds and ounces.
5	Hold	Press to hold weight. Press again to release weight.
6	Memory	Press to load weight.
7	Total & Average	Press to display total weight.
		Press and hold for average weight.
8	Clear	Clear all memory
		Press with  to select weight to clear
		Press  to confirm



Table 2 Display and Button Functions

Operating Scale







Note

Suspend the scale in a secure location.
Use scale in a vertical position only.

1. Press  to power on.
2. Press  to select units.
3. Suspend container from hook if one will be used.
4. Press  to zero scale.
5. Place product on the scale, weight will appear in the display.

Setting Auto-Off Timing

1. Press  to power on
2. Press and hold . When *AOFF* displays, release.
3. Press  to select auto-off time (OFF, 120, 180, 240, 300 seconds).
4. Press  to return normal weighing mode.

Hold Function

1. Press ,  when weight stabilizes display will lock and arrow will be steady.
2. Press to release locked weight.

Multiple Weight Storage (Up to 8)

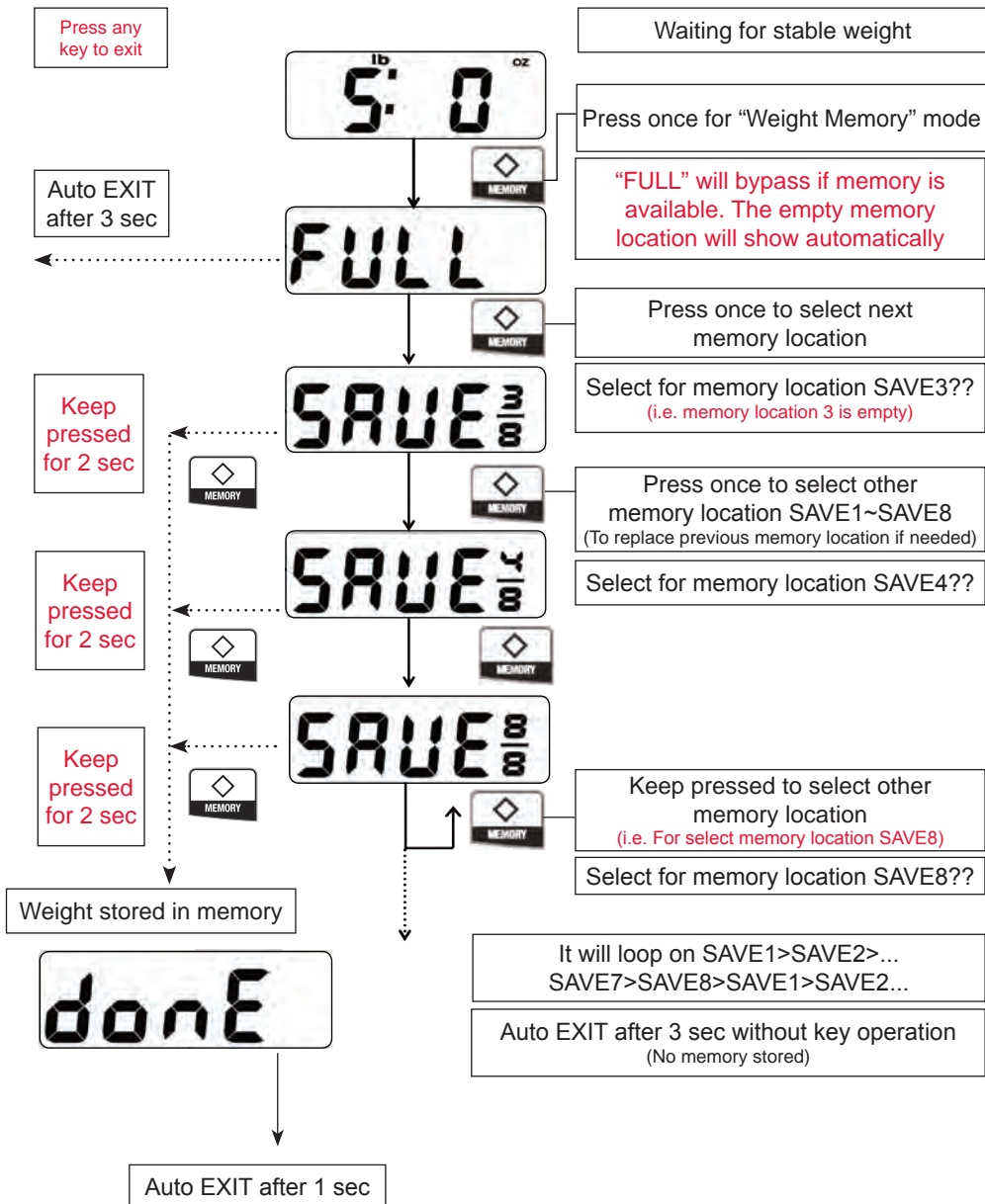

Total and Average Weight Stored

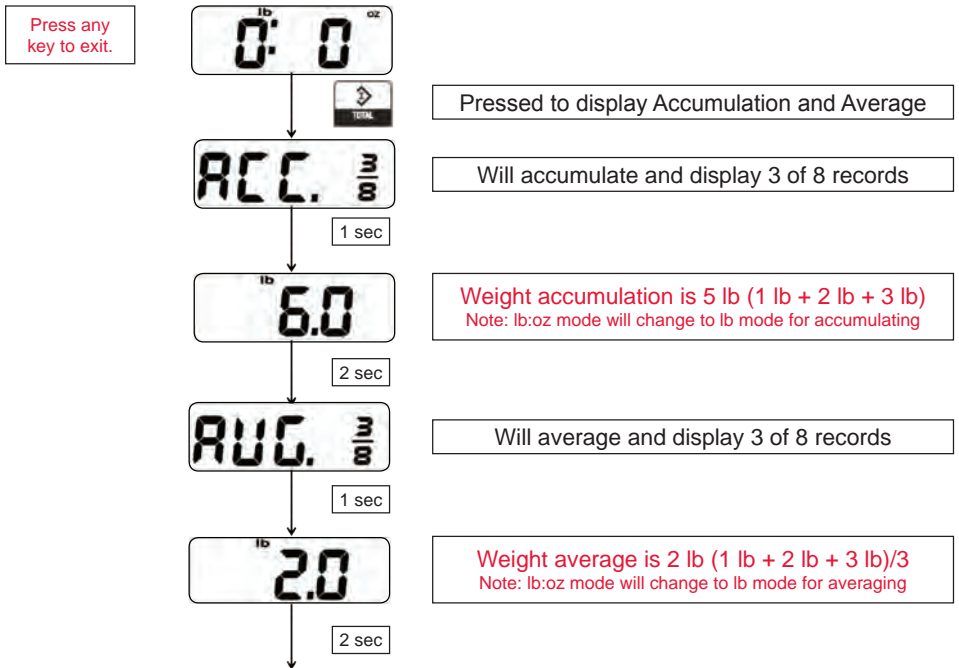

Clearing Weights

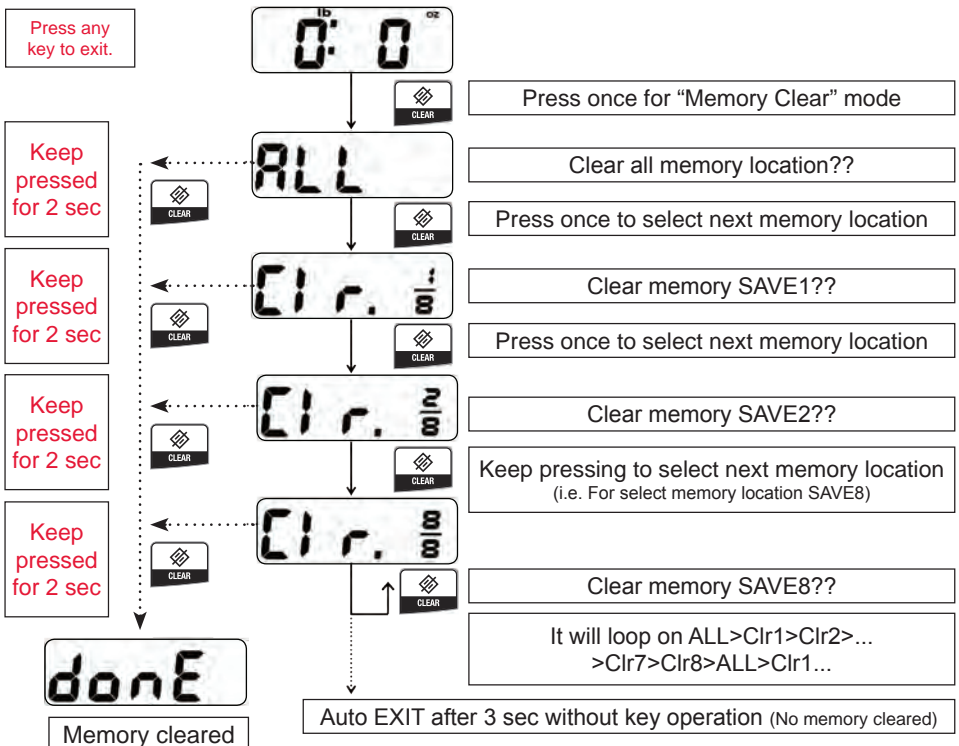

Available Weighmaster Models

The Weighmaster is available in three separate models with different weight capacities to fit your specific needs.

Model	Capacity x Graduations
WM10	10 x 0.01kg/22 x 0.02lb / 22lb x 1/4 oz
WM25	25 x 0.02kg/55 x 0.05lb / 55lb x 1/2 oz
WM45	45 x 0.05kg/99 x 0.1lb / 55lb x 1 oz

Certifications and Approvals



This device complies with Part 15 of the FCC Rules.
Operation is subject to the following two conditions:
(1) this device may not cause harmful interference, and
(2) this device must accept any interference that may cause undesired operation.

Intruder, 230 W. Coleman St., Rice Lake, WI 54868 USA
800-553-5129 • www.intruderinc.com

Intruder™

Pesar con confianza

WEIGH MASTER

WM10/WM25/WM45 Escala en el Sitio

Manual del usuario



Seguridad



Precaución

El incumplimiento de lo siguiente podría ocasionar lesiones menores o moderadas.

NO trabaje con la báscula ni la opere sin haber leído y comprendido este manual.

NO la utilice para fines distintos al pesaje.

NO deje las cargas desatendidas.

NO sobrecargue, esto puede dañar la báscula y dejará sin valor y efecto la garantía.

Limpieza



Important

- Apague siempre la báscula antes de limpiarla.
- Se recomienda utilizar paños con base de alcohol para limpiar.
- NO rocíe ni sumerja en agua al efectuar la limpieza.
- Abstenerse de usar líquidos corrosivos o limpiadores de alta presión.
- La limpieza incorrecta dejará sin valor y efecto la garantía.

Para insertar/cambiar la batería

Cuando aparezca **LO** en la pantalla, reemplace las baterías con dos baterías AA de 1.5V.

1. Quite la tapa de las baterías que se ubica en el lado posterior de la báscula.
2. Retire las baterías y deséchelas de manera apropiada.
3. Instale baterías AA nuevas de acuerdo al diagrama ubicado en la cavidad para baterías.
4. Vuelva a colocar de manera segura la tapa de las baterías.



Mensajes de error

Error	Acción	Pantalla
Baterías descargadas	Reemplace las baterías.	LO
Sobrecarga – La carga total excede la capacidad máxima. Retire inmediatamente el peso de la báscula.	Retire inmediatamente el peso de la báscula.	Err
Arriba de cero – La cuenta cero está por encima del rango de ajuste.	La báscula se apaga si el estado continúa durante 30 o más segundos.	
Abajo de cero La cuenta cero está por debajo del rango de ajuste.	La báscula se apaga si el estado continúa durante 30 o más segundos.	ErrL
Error de EEPROM	Solicite servicio.	ErrE

Table 1. Mensajes de error

Garantía limitada

Todos los sistemas y componentes tienen garantía de un año contra defectos materiales y de mano de obra. Para obtener más información, consulte www.intruderinc.com.

Pantalla y botones de funciones



Figura 2. Báscula colgante



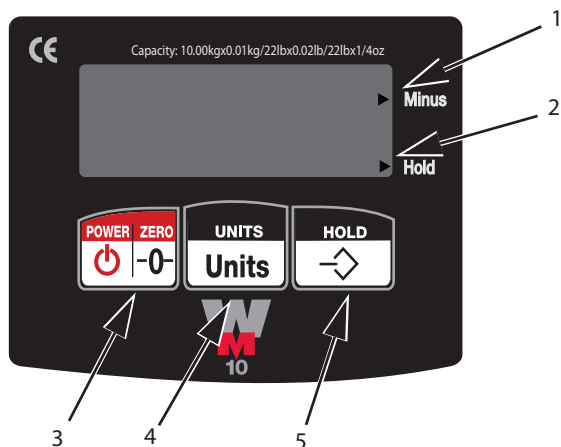

Botón	Elemento	Descripción
1	Minus (menos)	Significa que el peso es negativo.
2	Hold (colgar)	Significa que el peso se ha colgado.
3	Power/Zero (encendido/cero)	Presione para encender la báscula.
		Presione para restablecer en cero la báscula.
		Presione y sostenga para apagar la báscula
4	Units (unidades)	Seleccione kilogramos, libras o libras y onzas.
5	Hold (colgar)	Presione para colgar peso. Presione otra vez para liberar peso.

Table 2. Pantalla y funciones de botones



Para operar la báscula





Nota Cuelgue la báscula en un lugar seguro.
Use la báscula solamente en posición vertical.

1. Presione  para encender.
2. Presione  para seleccionar unidades.
3. Cuelgue el contenedor en el gancho, si es que se va a utilizar uno.
4. Presione  para restablecer en cero la báscula.
5. Coloque el producto en la báscula, el peso aparecerá en la pantalla.
6. Para apagar la báscula, presione y sostenga .



Función para colgar

1. Presione , cuando se establezca el peso, la pantalla se bloqueará y la flecha estará fija.
2. Presione  para liberar el peso que se ha bloqueado.



Multiple Weight Storage (up to 8)

	Display
Press  to power on.	0.0
Loading 5kg	5.0
Press  3 sec	ACC 1 (display for 3 sec) ↓ (turn to loading weight) 5.00

Average Weight and Total Weight Stored

	Display	
Press  to power on.	0.0	
Press  3 sec	ACC 5 (display for 3 sec) ↓ 20.00 (display for 3 sec) ↓ 4.00 (display for 3 sec) ↓ 0.0 (normal mode)	<p>If you have 5 memory weights, it will show ACC 5, if you have 7, it will show ACC 7</p> <p>Display shows "ACC 5"</p> <p>Total weight</p> <p>Average weight</p>





Clearing Weights

	Display
Press  to power on.	0.0
Press  &  (at same time)	ACC 0 (display for 3 sec) ↓ 0.0 (normal mode)

Capacidad x Graduaciones





Modelo	Capacidad x Graduaciones
WM10	10 x 0.01kg/22 x 0.02lb / 22lb x 1/4 oz
WM25	25 x 0.02kg/55 x 0.05lb / 55lb x 1/2 oz
WM45	45 x 0.05kg/99 x 0.1lb / 55lb x 1 oz

Para ajustar el apagado automático

1. Presione  para encender.
2. Presione y sostenga . Suelte cuando aparezca *ROFF*.
3. Presione  para seleccionar el tiempo de apagado automático (OFF, 120, 180, 240, 300 segundos).
4. Presione  para regresar al modo de pesaje normal.

Calibración

Calibre utilizando el método siguiente:

1. Presione y **sostenga** .
2. Presione  tres veces, aparece ZERO COUNT (cuenta en cero).
3. Presione , aparece el cero.
4. Presione  para seleccionar la unidad de calibración.
5. Coloque la cantidad apropiada de peso en la báscula a (consulte véase la Table 3), la pantalla muestra el rango del conteo.
6. Presione , aparece CAL (calibrar), luego el peso.
7. Retire el peso, vuelva a encender la báscula y la calibración ha terminado.

Modelo	kg	lb
WM10	10kg	20lb
WM25	20kg	40lb
WM45	20kg	40lb

Table 3. Pesos de calibración

Certificaciones y autorizaciones



Este dispositivo cumple con la Sección 15 del reglamento de FCC.
Su funcionamiento está sujeto a las siguientes condiciones:
(1) este dispositivo no debe ocasionar interferencia perjudicial, y
(2) este dispositivo debe aceptar cualquier interferencia que pudiera ocasionar un funcionamiento no deseado.

Intruder™

Peser avec confiance

WEIGH MASTER

WM10/WM25/WM45 Échelle sur le site

Manual d'utilisation



Sécurité



Attention

Le manque de prudence pourrait entraîner des blessures superficielles ou modérées.

VEUILLEZ NE PAS manipuler ou utiliser la balance avant d'avoir lu et compris ce manuel.

VEUILLEZ NE PAS utiliser cet appareil pour d'autres fonctions que le pesage.

VEUILLEZ NE PAS laisser des charges sur la balance sans surveillance.

VEUILLEZ NE PAS surcharger la balance - Ceci pourrait l'endommager et de ce fait annuler la garantie.

Entretien



Important

- Veuillez toujours éteindre la balance avant de la nettoyer.
- Il est recommandé d'utiliser des lingettes à base d'alcool pour nettoyer la balance.

- **VEUILLEZ NE PAS** vaporiser de l'eau sur la balance ou la plonger dans l'eau lors du nettoyage.
- Veuillez éviter l'emploi de produits corrosifs ou de nettoyeurs à haute pression.
- Un mauvais entretien de l'appareil pourrait entraîner l'annulation de la garantie.

Insérer / Remplacer les piles

Lorsque **Lo** s'affiche sur l'écran, veuillez remplacer les deux piles AA 1,5 V.

1. Retirer le couvercle du compartiment des piles situé au dos de la balance.
2. Retirer les piles usagées et jeter les dans un conteneur prévu à cet effet.
3. Insérer les nouvelles piles AA dans le compartiment comme indiqué sur le schéma.
4. Refermer correctement le compartiment des piles.



Messages d'erreur

Erreur	Solution / Action	Affichage
Piles déchargées	Remplacer les piles.	Lo
Surcharge - Poids total supérieur à la capacité maximale.	Retirer immédiatement la charge de la balance.	Err
Supérieur à zéro - Correction trop importante pour ajuster à zéro.	La balance s'éteindra si le message s'affiche pendant au moins 30 secondes.	ErrL
Inférieur à zéro - Correction trop petite pour ajuster à zéro.	La balance s'éteindra si le message s'affiche pendant au moins 30 secondes..	ErrE
Erreur de l'EEPROM	Appeler le service dépannage.	ErrE

Tableau 1. Messages d'erreur

Garantie limitée

Tous les appareils et les composants sont garantis contre les défauts de fabrication et de matériaux pendant un an. Pour plus d'informations, veuillez visiter le site www.intruderinc.com.

Affichage et fonctions des touches

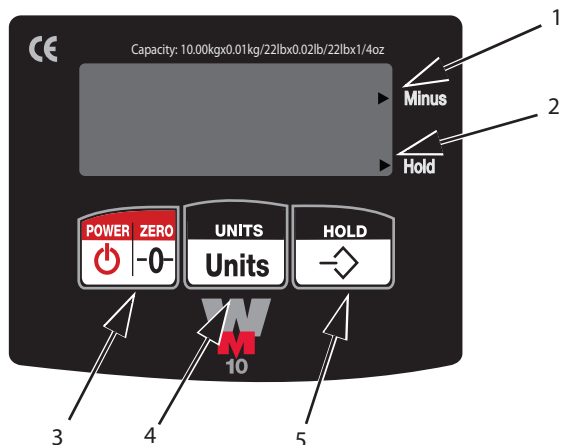

Illust. 2. Balance à crochet





Réf.	Touche	Description
1	Minus (Moins)	Indique un poids négatif
2	Hold (Maintenir)	Pour maintenir le poids affiché.
3	Power/Zero (Marche-Arrêt/Zéro)	Appuyer pour allumer la balance. Appuyer pour réinitialiser la balance à zéro. Appuyer et maintenir appuyé pour éteindre la balance.
4	Units (Unités)	Pour sélectionner les unités en kilogramme, livre ou livre et once.
5	Hold (Maintenir)	Appuyer pour maintenir le poids affiché/Appuyer de nouveau pour effacer le poids affiché.

Tableau 2. Affichage et fonctions des touches.



Utilisation de la balance





À noter *Suspendre la balance à une fixation solide.*
Utiliser uniquement la balance en position verticale.

- Appuyer sur la touche  pour allumer l'appareil.
- Appuyer sur la touche  pour sélectionner les unités de poids.
- En cas d'utilisation d'un conteneur, veuillez le suspendre au crochet.
- Appuyer sur la touche  pour initialiser la balance à zéro.
- Placer le produit sur la balance, le poids s'affichera sur l'écran.
- Pour éteindre l'appareil, maintenir la touch  appuyée.



Fonction "Maintenir"

- Appuyer sur la touche , lorsque l'affichage du poids se stabilise, l'écran bloquera alors le poids affiché ainsi que la position de la flèche.
- Appuyer sur la touche  afin de relâcher le poids bloqué.



Multiple Weight Storage (up to 8)

	Display
Press  to power on.	0.0
Loading 5kg	5.0
Press  3 sec	ACC 1 (display for 3 sec) ↓ (turn to loading weight) 5.00

Average Weight and Total Weight Stored

	Display	
Press  to power on.	0.0	
Press  3 sec	ACC 5 (display for 3 sec) ↓ 20.00 (display for 3 sec) ↓ 4.00 (display for 3 sec) ↓ 0.0 (normal mode)	<p>If you have 5 memory weights, it will show ACC 5, if you have 7, it will show ACC 7</p> <p>← Display shows "ACC 5"</p> <p>← Total weight</p> <p>← Average weight</p>





Clearing Weights

	Display
Press  to power on.	0.0
Press  &  (at same time)	ACC 0 (display for 3 sec) ↓ 0.0 (normal mode)

Capacité x Graduations





Modèle	Capacité x Graduations
WM10	10 x 0.01kg/22 x 0.02lb / 22lb x 1/4 oz
WM25	25 x 0.02kg/55 x 0.05lb / 55lb x 1/2 oz
WM45	45 x 0.05kg/99 x 0.1lb / 55lb x 1 oz

Ajuster Auto - Arrêt

1. Appuyer sur la touche  pour allumer l'appareil.
2. Maintenir la touche  appuyée jusqu'à ce que "AOF F" s'affiche sur l'écran.
3. Appuyer sur la touche  pour sélectionner le temps d'arrêt auto (ARRÊT, 120, 180, 240, 300 secondes).
4. Appuyer sur la touche  pour revenir au mode de pesage normal.

Calibrage

Calibrer l'appareil en effectuant les opérations suivantes:

1. Maintenir la **touch**  appuyée
2. Appuyer trois fois sur la touche , ZERO COUNT s'affiche.
3. Appuyer sur la touche , zéro s'affiche.
4. Appuyer sur la touche  pour sélectionner l'unité de calibrage.
5. Poser la charge adéquate sur la balance (Consulter le Tableau 3). L'écran affiche des valeurs de poids.
6. Appuyer sur la touche , "CAL" s'affiche sur l'écran, puis le poids.
7. Retirer le poids, éteindre puis rallumer la balance le calibrage est terminé.

Modèle	kg	lb
WM10	10kg	20lb
WM25	20kg	40lb
WM45	20kg	40lb

Tableau 3. Calibrage Poids

Certificats et agréments de conformités aux normes CE



Cet appareil est conforme à l'article 15 des règlements de la FCC.
Son fonctionnement est soumis aux deux conditions suivantes :

- (1) cet appareil ne doit pas entraîner d'interférences préjudiciables, et
- (2) cet appareil doit accepter toute interférence pouvant entraîner un mauvais fonctionnement de l'appareil.