



## JA3500S-E



# USER MANUAL

Operative Manual & Instructions for Use and Maintenance

## HYDRAULIC AUTOMOBILE LIFT

Model:

Serial No:

Year of Production:

**Manufacturer:**

**Jema Autolifte A/S**

**AUTHORISED SERVICE CENTRE:**

|                                   |
|-----------------------------------|
| <b>AUTHORISED SERVICE CENTRE:</b> |
|                                   |

## Contents

Manufacturer and informations

Packing, transport and storage

Introduction

CHAPTER 1: Description of the lift

CHAPTER 2: Technical specifications

CHAPTER 3: Safety

CHAPTER 4: Installation

CHAPTER 5: Calibration

CHAPTER 6: Mode of Operation

CHAPTER 7: Maintenance and care

CHAPTER 8: Troubleshooting

Appendix

**THIS USER'S MANUAL IS WRITTEN IN THE MANUFACTURER'S LANGUAGE, AND IN OTHER COMMUNITY LANGUAGES. IN CASE OF COMPLAINT, FOR LEGAL PURPOSES, THE VERSION IN ITALIAN LANGUAGE ONLY WILL APPLY. THE MANUFACTURER DISCLAIMS ANY LIABILITY FOR DIRECT AND/OR INDIRECT DAMAGES CAUSED BY POOR TRANSLATION OR WRONG TEXT INTERPRETATION.  
CAREFULLY READ THE INSTRUCTIONS GIVEN IN THIS MANUAL BEFORE USING THE LIFT**

## **WARRANTY**

The manufacturer warrants lifts and the relevant accessories for 12 months after purchase date. This warranty consists in the repair or replacement.

- free of charge - of those parts that, after a careful analysis by the Manufacturer's Technical Service, turn out to be faulty from origin. Warranty is limited to material defects and becomes null and void if the returned parts are tampered with or disassembled by unauthorized staff. Any liability for direct and indirect injuries to people, animals or property due to machine failure or malfunction are excluded from warranty. The expenses deriving from lubricants replacement, transport charges, and any customs duty, VAT and any other expense not specified in the supply contract are at the purchaser's charge. The replacement and repair of parts under warranty, anyway, do not extend warranty terms. The purchaser will nevertheless be entitled to assert its rights on warranty, specified in the supply contract. Should the parties not be willing to submit any dispute arising from the supply contract to arbitration, or in any other case where the judgement of a body of the ordinary competent court is required, the Court of Vicenza will be the only competent court on the territory.

## **DISCLAIMER**

Upon delivery, please check that the product has not been damaged during transportation, and that the accessories coming with it are intact and complete.

Any complaint shall be filed within 8 days after lift delivery date. Besides the cases envisaged by the supply contract, the warranty becomes null and void:

- In case of a maneuver error caused by the operator.
- If the damage is caused by poor maintenance.
- If the envisaged capacity is exceeded.
- If the machine has been somehow modified, and the damage has been caused by such a modification, due to repair operations by the user without the authorization of the manufacturer or after fitting non-original spare parts.
- If the instructions described in the user's manual are not complied with.

## PACKING, TRANSPORT AND STORAGE

### Packing (Picture 1)

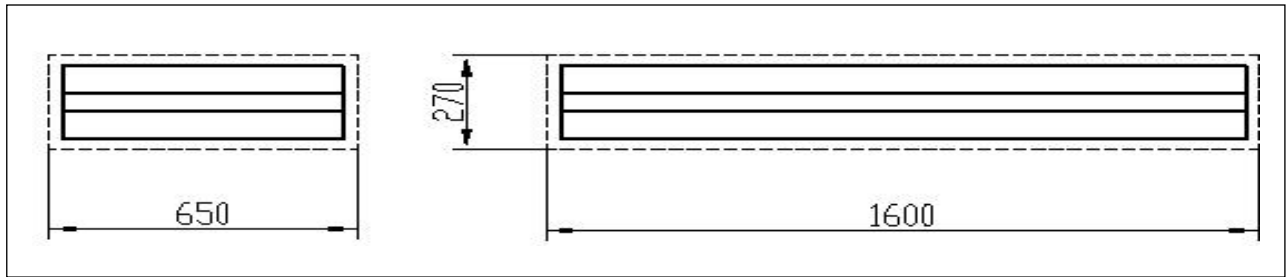

Picture 1

### Transport (Picture 2)



Packaging can be lifted or moved by lift trucks, cranes or overhead cranes. In case of slinging, a second person must always take care of the load, in order to avoid dangerous oscillations.

During loading and unloading operations, goods must be moved by appropriate vehicles such as trucks, ships or forklift.

At the moment the goods are delivered, verify immediately that all of the items specified in the delivery notes are included.

If finding missing parts, possible defects or damages to the goods caused during the transport you should immediately inform the person in charge, or the carrier.

The lifter is heavy! Don't move it manually, the safety on workplace is very important.

Furthermore, during loading and unloading operations, goods must be handled as shown in the picture. (Picture 2)

### Storage:

- The equipment should be stocked inside the warehouse, if stocked outside one has to make it sure that the equipment stays off the water.
- Use box tracks for ground transportation, use container when shipping.
- The control box should be placed perpendicularly during the transport.
- Temperature range for machine storage: min -25°C – max + 55°C

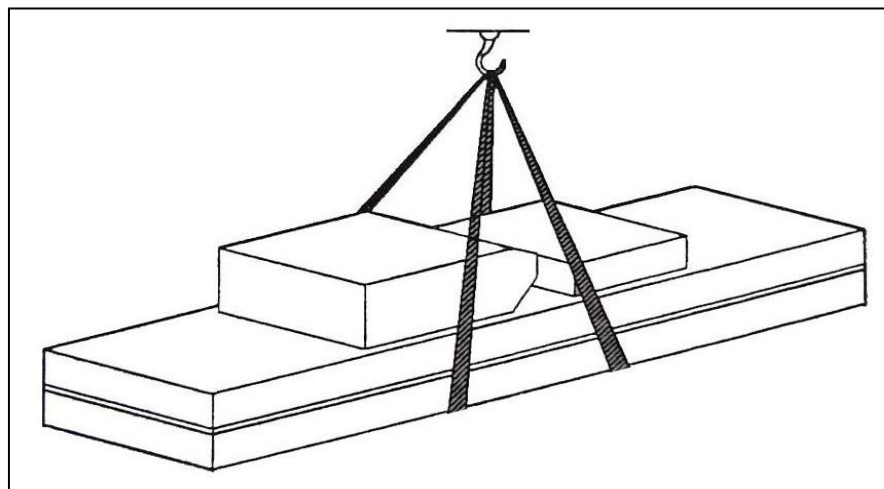

Picture 2

## Manual Introductions



This manual has been prepared for those who are expert in the use of the lifters, operators and technicians responsible for the routine maintenance.

Workers should read carefully the 'Maintenance & User Manual' before carrying out any operation on the lift.

This manual contains important information regarding:

Personal safety of the operator and the maintenance workers.

Lift safety

The safety of the lifted vehicles

### CONSERVING THE MANUAL



This manual is an integral part of the lift.

The manual must be kept in the vicinity of the lift, so that the operator and maintenance staff can easily locate and consult the manual at any time.

We particularly recommended reading Chapter 3 which contains important information and safety warnings.



**The lift is designed and manufactured according to the European Standard.**

Lifting, transport, unpacking, assembly, installation, starting up, initial adjustment and testing, extraordinary maintenance, repair, overhauls, transport and dismantling of the lift are all operations that must be performed only by specialized personnel or by licensed dealer authorized by the manufacturer.

The manufacturer declines all responsibility for injury to persons and damages to vehicles and objects when any of the above mentioned, operations has been performed by unauthorized personnel or when the lift has been subject to improper use.



This manual indicates: the operative and safety aspects that may be useful to the operator and maintenance workers. For a better understanding of the structure and its functioning, workers must carefully read the 'Maintenance & Use Manual'.

In order to understand the terminology used in this manual, maintenance and repair personnel must have the ability to interpret correctly the drawings and the descriptions contained in the manual and be able to read and understand correctly the language of the country in which the lift has been installed and the manual has been written. They must have the ability to read technical drawings and have a specialized knowledge both in mechanical and engineering field.

**OPERATOR:** person authorized to use the lift

**MAINTENANCE FITTER:** person authorized for routine maintenance on the lift.



**Manufacturer reserves the right to make changes to the user manual if there are technological improvements.**

## CHAPTER 1: DESCRIPTION OF THE LIFT

### Using the Lift:

This lifter can lift each kind of vehicle whose weight is less than 3500kg. It is suitable to be used in vehicle tests, maintenance, and automobile care, it is also suitable to be installed on floor or in floor without the need of structures.

### Structure Features:

- Thanks to the narrow structure of the scissors, it is not required too much space for the in-floor installation .
- Independent control box, low-voltage controlling, excellent security.
- Hydraulic compensation.
- Equipped with hydraulic (H) safety lock, depending on the version requested.
- Equipped with safety valve to protect from hydraulic failure and/or over loading. So if the oil pipe breaks, the machine will not fall quickly when in UP position.
- Equipped with manual pump for lowering operation when there is no electricity.

### Equipment:

- Complete Lifter
- Control box

### Foundation

The lift has to be installed in a floor made of cement and concrete, like the manual explains with technical information shown at page 9.

### Structure of the Lifter

A main lifting platform activated by a double scissor platform, a control box.

### Control box

Under the control box it is located the electrical system. The oil tank, the hydraulic pump, the valve and other control systems are located in the underlying area, easily accessible through the two inspection doors.



Scissor lift is designed and built to lift all kinds of vehicles, all other use is unauthorized. In particular, the lift is not suitable for washing spray work. And do not lift vehicles whose weight exceed the maximum weight.

**CHAPTER 2: SPECIFICATIONS**

|                         |                                                                                                                |           |  |
|-------------------------|----------------------------------------------------------------------------------------------------------------|-----------|--|
| Machine type            |                                                                                                                | JA3500S-E |  |
| Drive                   | Electrical hydraulic                                                                                           |           |  |
| Safety Lock             | Hydraulic                                                                                                      |           |  |
| Lifting weight          |                                                                                                                | 3500kg    |  |
| Lifting height          | 1950mm                                                                                                         |           |  |
| Platform initial height |                                                                                                                | 105mm     |  |
| Platform length         | 1420mm                                                                                                         |           |  |
| Platform width          | 650mm                                                                                                          |           |  |
| Lifting time            | ≤50s                                                                                                           |           |  |
| Descent time            | ≤60s                                                                                                           |           |  |
| Whole machine length    | 2270mm                                                                                                         |           |  |
| Whole machine width     | 2130mm                                                                                                         |           |  |
| Weight                  |                                                                                                                | 900kg     |  |
| Voltage                 | AC 400V or 230V ± 5% 50Hz(or 60HZ--special ordered) Please check the nameplate on the control box for details! |           |  |
| Engine power            | 2.2kw                                                                                                          |           |  |
| Hydraulic oil           | 18L – H46 (not supply by the manufacturer)                                                                     |           |  |
| Working temperature     | From + 5°C to +40°C                                                                                            |           |  |
| Working humidity        | 30-95%                                                                                                         |           |  |
| Noise level             | < 76db                                                                                                         |           |  |
| Installation height     | Height above the sea level ≤1000M                                                                              |           |  |
| Storage temperature     | -25°C~55°C                                                                                                     |           |  |
| Installation place      | Indoor                                                                                                         |           |  |



Lift dimension picture (Picture 3):

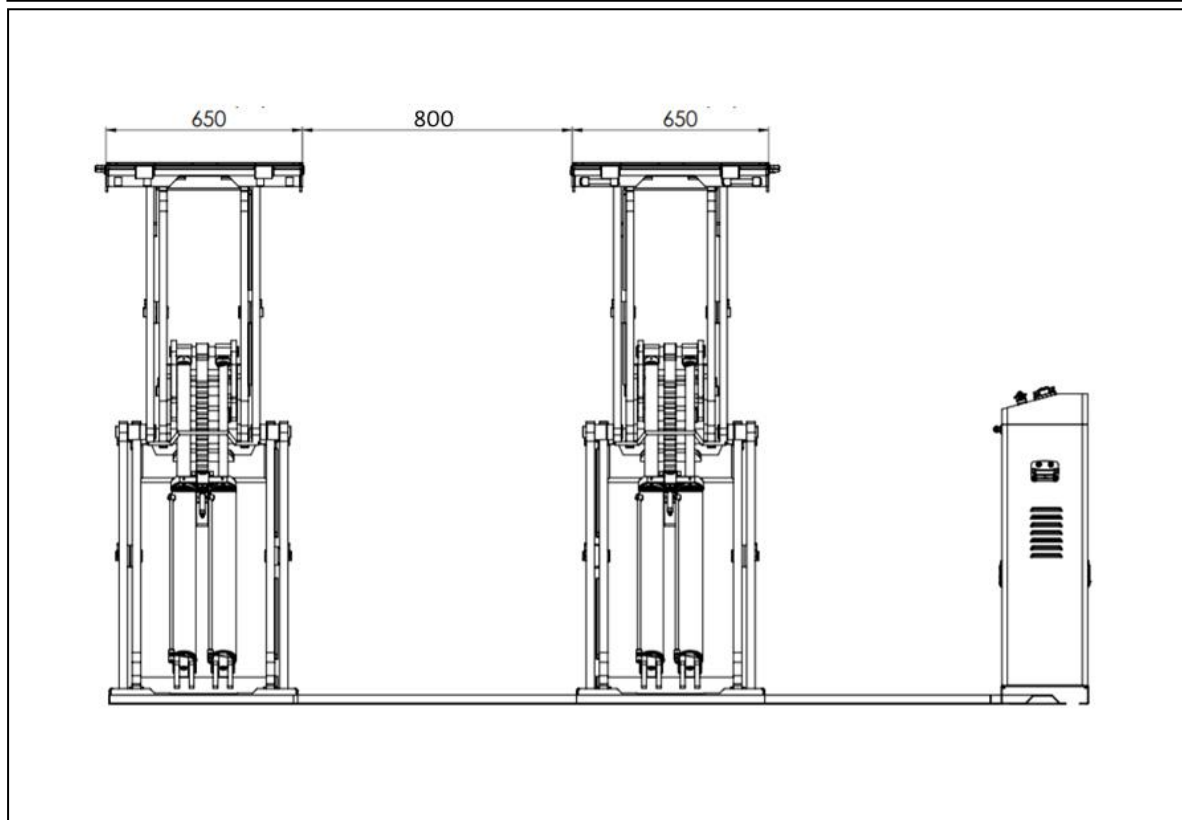
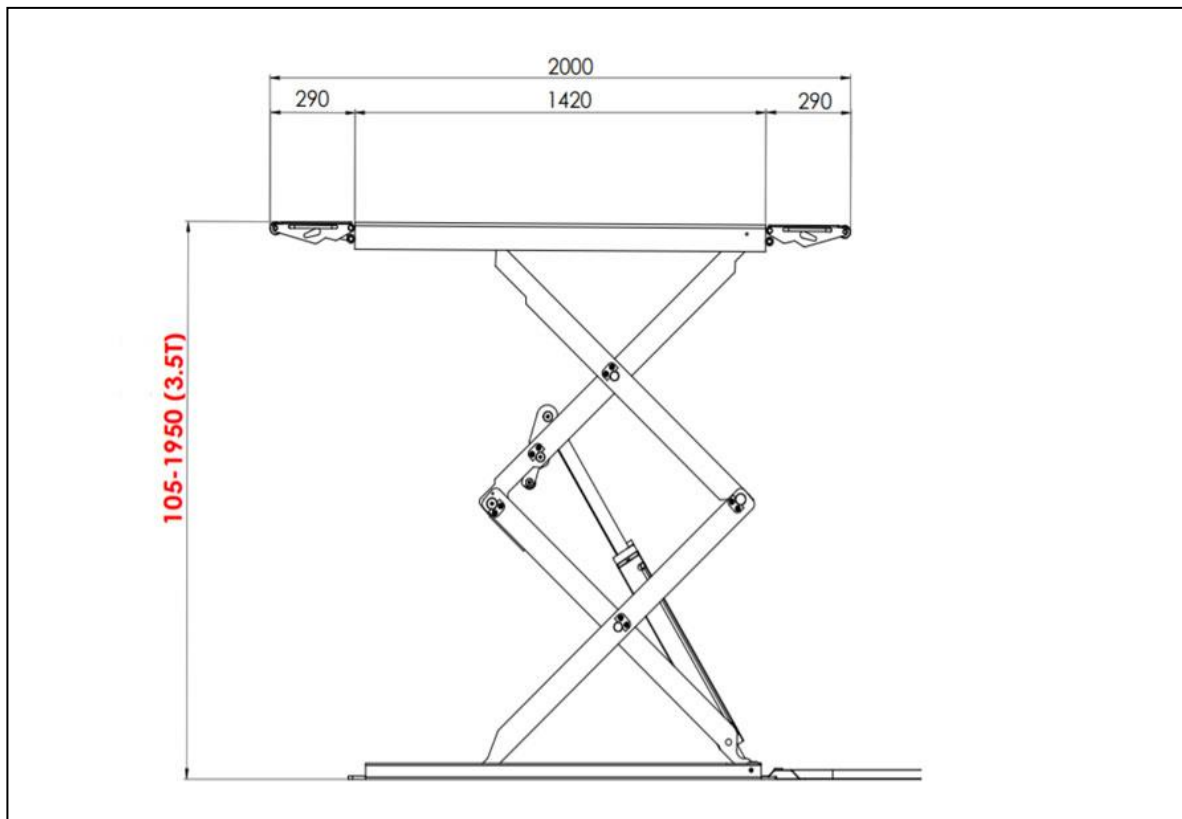

**Lift groundwork drawing-for in ground installation (Picture 4):**

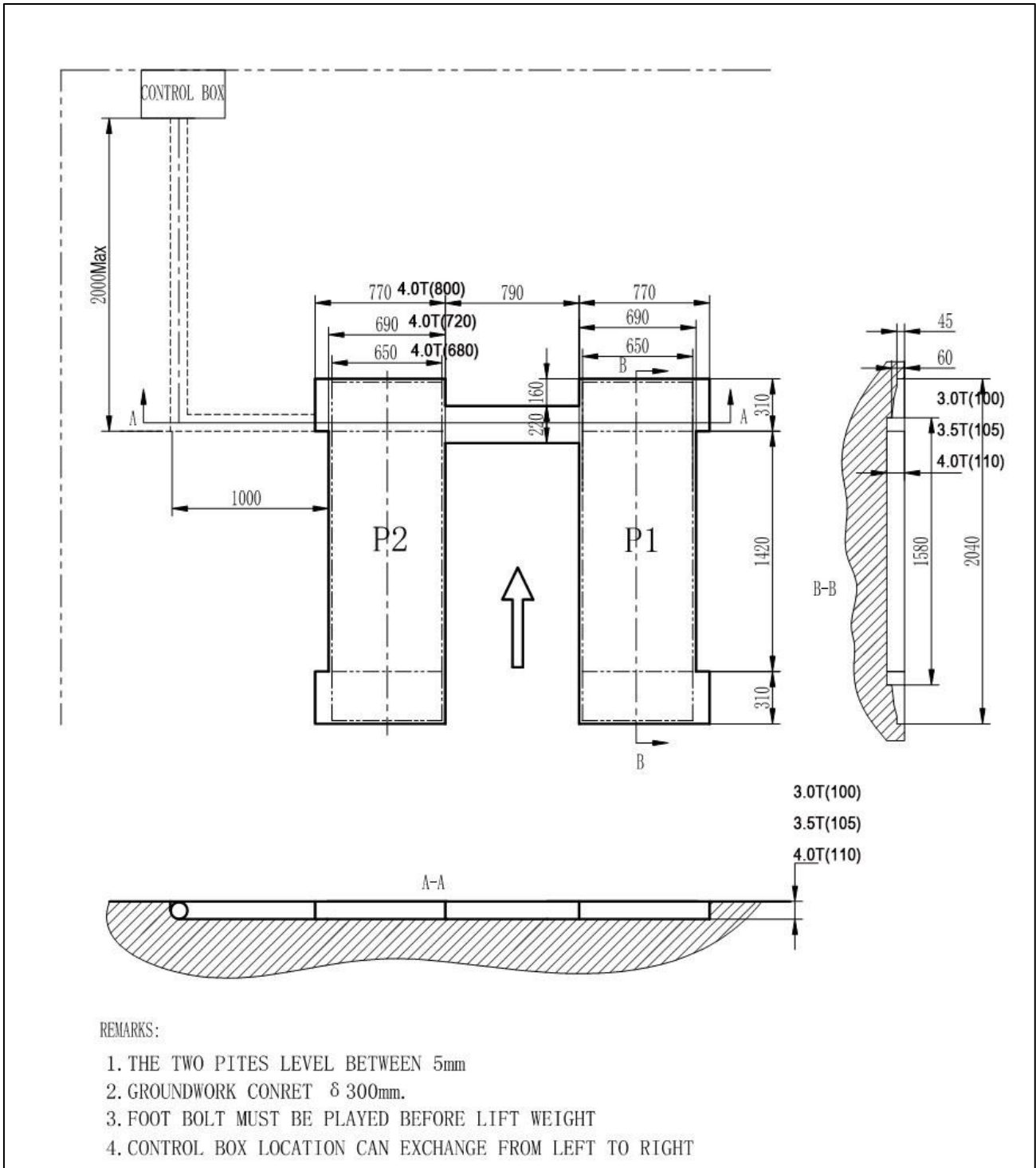

| <b>Motor</b>            |                        |
|-------------------------|------------------------|
| Type                    | MS90L                  |
| Power                   | 2.2kw                  |
| Voltage                 | AC 400 or 230V ±5%     |
| Current                 | 400V: 5A 230V: 10A     |
| Frequency               | 50Hz /60 Hz (optional) |
| Poles                   | 3+N+PE                 |
| Speed                   | 1400 r/min             |
| Building shape          | B14                    |
| Energy efficiency Class | F                      |

| <b>Pump</b>                     |                    |
|---------------------------------|--------------------|
| Type                            | hydraulic pump     |
| Model                           | P4.3               |
| Flux                            | 4.3cc/3.7cc (60Hz) |
| Joint type                      | direct connection  |
| <b>Safety valve</b>             |                    |
| Setting pressure                | 280 bar            |
| Adjustable working pressure     | 150~300 bar        |
| Suggested pneumatic pressure(M) | 6 bar              |

## INSTALLATION SCHEME FOR SCISSOR LIFT

### Requirements:

- Concrete type 425#, drying time 15 days
- Clean the basic layer before installing the lift. -Thickness of concrete  $\geq 150\text{mm}$ , leveling of whole length  $\leq 5\text{mm}$ .

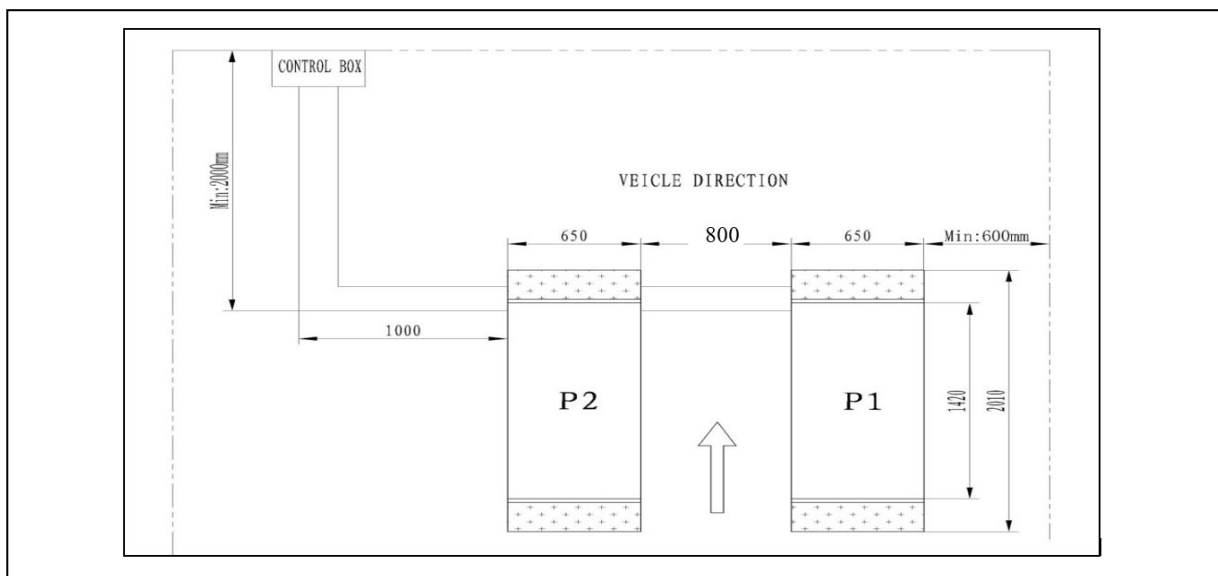

Picture 4 (Ground drawing)

Note: The ending part of the lift platform nr. P1 and nr. P2 represents the concrete structure. When the thickness of the inside level ground is less than 150mm, the end of P1 and P2 should be taken to 2500x2500mm length and the thickness of the concrete should be taken to  $\geq 150\text{mm}$ .

The minimum thickness of the concrete, and its right leveling, are main keys to complete the alignment operation successfully.

TYPES OF VEHICLES THIS LIFT IS SUITABLE FOR:

THE LOWER PARTS OF THE VEHICLES, LIKE SPORTIVE CAR UNDERBODY, COULD INTERFERE WITH SOME STRUCTURAL PARTS OF THE LIFT.

The lift will also handle customized or non-standard vehicles assuming they are within the maximum specified carrying capacity.

Also, the personnel safety zone must be redefined in relation to vehicle with unusual dimensions.

Read carefully and completely this chapter since important information is included about the operator safety in the case of improper use of the lift.



following text there are some clear explanations regarding certain situations of risk or danger that may arise during the operation or maintenance on the lift, the safety devices installed and the correct use of such systems, residual risks and operative procedures to use (general precautions used to eliminate potential hazards).



Lifts are designed and built to lift vehicles and hold them in the elevated position in an enclosed workshop. All other uses of the lifts are unauthorized. In particular, the lifts are not suitable for:

- Washing spray work.
- Creating raised platforms for personnel or lifting personnel.
- Use as a press for crushing purposes.
- Use as elevator;
- Use as elevator for single parts of vehicles.



The manufacturer is not liable for any injury to persons or damages to vehicles and to other property caused by the incorrect and unauthorized use of the lifts.

During lifting and descendant phases, the operator must remain in the control station, like the diagrams illustrates.

As the diagrams illustrate, the presence of persons inside the indicated danger zone is strictly prohibited. Persons are admitted to the area beneath the vehicle only when the vehicle is already in the elevated position, when the platforms are stationary, and when the mechanical safety devices are firmly engaged.



**DO NOT USE THE LIFT WITHOUT THE PROTECTION DEVICES OR WITH THE PROTECTION DEVICES INHIBITED.  
IN FOLLOWING THESE RULES CAN CAUSE SERIOUS INJURY TO PERSONS, AND IRREPARABLE  
DAMAGE TO THE LIFT AND/OR TO THE VEHICLE BEING LIFTE**

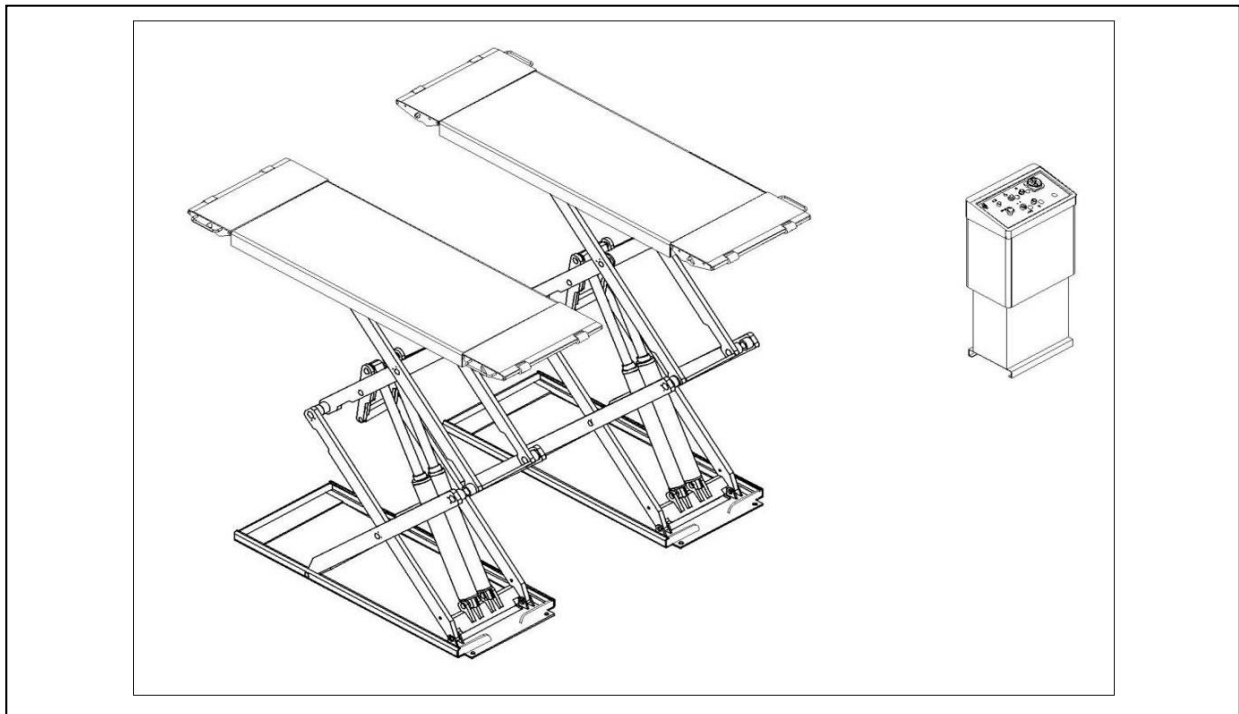

Picture 5

## CHAPTER 3: SAFETY

### GENERAL PRECAUTIONS



The operator, the installer and the maintenance fitter are required to observe the prescriptions of the safety regulation in force in the country of installation of the lift.

Furthermore, the operator and maintenance fitter must:

- Always work in the stations specified and illustrated in this manual.
- Never remove or deactivate the guards and the mechanical, electrical or other types of safety devices.
- Read the safety notices placed on the lift and the safety information in this manual.

In the manual all safety notices are shown as follows:



**WARNING:** indicates operations that are unsafe and can cause minor injury to persons and/or damage to the lift, the vehicle or other property.

**CAUTION:** indicates possible danger that can result in serious injury to people and/or damage to properties.



**RISK OF ELECTRIC SHOCK:** a specific safety notice placed on the lift in areas where the risk of electric shock is particularly high.

### RISK AND PROTECTION DEVICES

We shall now examine the risks that operators or maintenance fitters may be exposed to when the vehicle is standing on the platforms in its raised position, together with the various safety and protection devices adopted by the manufacturer to reduce all such hazards to the minimum:

For an optimal personal and vehicles safety, observe the following regulations:

- Do not enter the danger areas when vehicles are being lifted. (Picture 5)
- Make sure the vehicle is positioned correctly. (Picture 6)
- Be sure to lift only approved vehicles, never exceeding the specified carrying capacity, maximum height, and projection (vehicle length and width);
- Make sure that there is no person on the platforms during up and down movements and during the standing position.

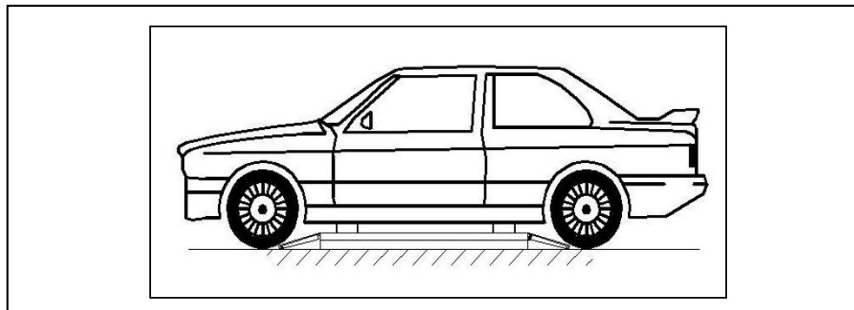

Picture 6

### GENERAL RISKS FOR LIFTING OR DESCENDANT PHASES:

The following safety equipment is used to protect from overloading or from the possibility of engine failure. In the condition of over loading, the overflow valve will open, and it will directly return the oil to its tank. (Picture 7) Each bottom of the oil cylinders are equipped with antiknock valve. If the oil pipe bursts, the specific valve will be activated and it will limit the lowering speed of the platforms. (Picture 8)



Picture7



Picture 8



### RISKS FOR PERSONNEL

This manual illustrates potential risks for operators, maintenance fitters or any other person standing in the area around the lift when an incorrect use of it is carried out.

### RISKS IN USING THE LIFT

During the up and down operations, the personnel must stand within the safety area, following the rules and the instruction given by the manufacturer.

During the up and down operations no one is allowed to work beneath the movable parts of the lift, but he has stand in the safety zone.

### RISK OF IMPACT (Picture 9)

Before the operator begins up and down movements, make sure that there are no personnel inside the danger zone. When, due to operational reasons, the lift is stopped at relatively low elevations (lower than 1.75m above the ground) personnel must be careful to avoid impact with parts of the machine that are not marked with special colors.

### RISK OF FALLING OFF (PERSONNEL)

During up and down operations personnel are prohibited from entering the platforms and the vehicle lifted to avoid falling off.

### RISK OF FALLING (VEHICLE) (Picture 10)

This hazard may arise in the case of incorrect positioning of the vehicle on the platforms, overweight of the lifted vehicle, or in the case the vehicle dimensions are not compatible with the capacity of the lift.

When the platform is being tested, the vehicle engine cannot be turned on.

There is nothing that should be placed on the lift-lowering area and the movable parts of the lift.

### RISK OF SLIPPING (Picture 10)

The area beneath and immediately surrounding the lift, or its platforms, must be kept clean. Remove any oil spills immediately. Keep Clean the working area.

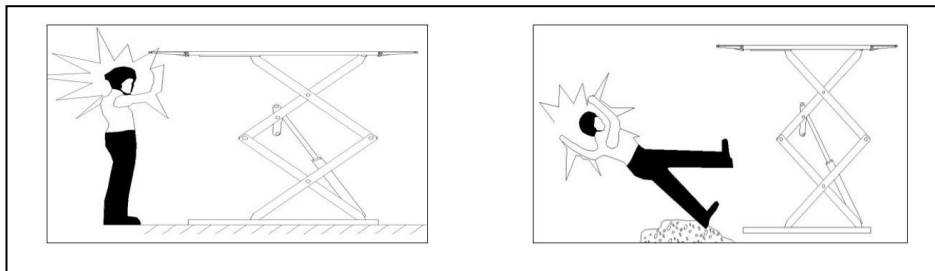

Picture 9

Picture 10

### RISK OF ELECTRIC SHOCK

The risk of electric shock in the insulated areas is shattered.

Do not use jets of water, steam solvents or paint next to the lift and take special care to keep such substances away from the electrical control panel.



### RISKS RELATED TO INAPPROPRIATE LIGHTING

The operator and the maintenance fitter must be able to assure that all the lift areas are properly and uniformly illuminated, in the respect of the laws in force in the place of installation.

During up and down operations, the operator should constantly observe the lift movements and he can only operate it through the operator safety zone. The handling of safety devices is strictly forbidden.

Never exceed the maximum carrying capacity and make sure that the lifted vehicle has no loads on board.

It is also essential to adhere scrupulously to all the regulations, maintenance and safety contained in this manual.

## CHAPTER 4: INSTALLATION



ONLY SKILLED AND AUTHORISED PERSONNEL ARE ALLOWED TO PERFORM THESE OPERATIONS. FOLLOW ALL THE INSTRUCTIONS SHOWN BELOW IN ORDER TO PREVENT POSSIBLE DAMAGE TO THE LIFT OR RISK OF INJURY TO PEOPLE.

Only Skilled technicians, named by the manufacturer or by an authorized dealer, are allowed to install the lift.

### INSTALLATION REQUIREMENTS

The lift must be installed respecting the specified safety distance from walls and any other equipment. (Picture 11)

The specified safety distance from the walls is at least 1000 mm. Take into consideration the necessary space to work easily, the space needed for the control site and also for a possible runway in case of emergency.

The room must be previously arranged with all the electrical and pneumatic devices needed by the lift functioning.

The room must be 4000 mm in height, at least.

The lift can be placed on any floor, if it is perfectly leveled and sufficiently resistant. ( $\geq 250$  kg/ cm<sup>2</sup>, the thickness of concrete  $\geq 150$  mm)

All parts of the lift must be uniformly illuminated with enough light to make sure that the adjustment and maintenance operations can be performed safely, and without reflective or dazzling light that may cause eye problems.

The integrity of the incoming product must be verified before the process of installing the machine is started.

Moving and installing operations must follow the process illustrated at picture 12.

For the transportation and the storage of the lift, please refer to “TRANSPORT AND STORAGE” page 4.

### Platform Installation:

- Place the two bases on their final position.
- The bottom of the oil cylinder is located on the front of the lift where there's the access for the vehicle.
- Use a forklift or other lifting equipments to move the platform (Picture 12).

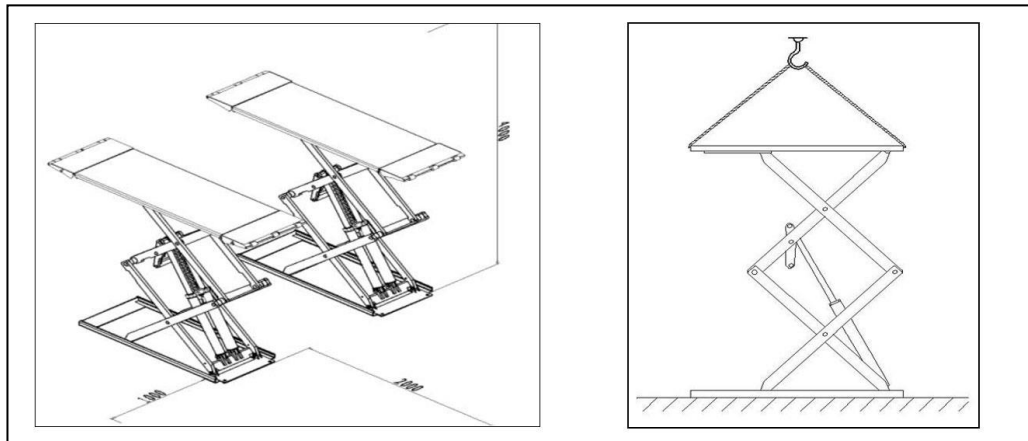

Picture 11

Picture 12



Avoid working under the moving lift when the hydraulic system is not fully equipped with oil. When a platform is being moved, adjust the space between the two bases and make it sure that they are fixed and parallel.



### POWER LINE CONNECTION

Connect the electrical and hydraulic line according to the diagrams shown.

When connecting the oil pipes, pay particular attention to the pipe joint protection to prevent foreign elements from entering the circuit and to avoid damages happen to the hydraulic system.



### ELECTRIC CIRCUIT CONNECTION:

Follow the line path stated in the ‘electrical diagram’ to connect electric circuit.

Only skilled persons are allowed to perform the operations.

- Open the front cover on the control box.

- Connection of power supply:

- The three-phase connection cables with 5 poles 400V (5 x 2.5 mm- cable dimension) are connected to the control box. The PE ground cable must be connected under the marked clamp and then connected to the plugs of the two bases.

- If the lift is operated at 230V three-phase, a different electrical diagram must be used. Request it to the lift manufacturer.

- If the lift is operated at 230V single-phase, a different electrical diagram must be used. Request it to the lift manufacturer.

- Connection of upper limit switch (SQ1): see the connection on the circuit diagram.

- Connection of lower limit switch (SQ2): see the connection on the circuit diagram.

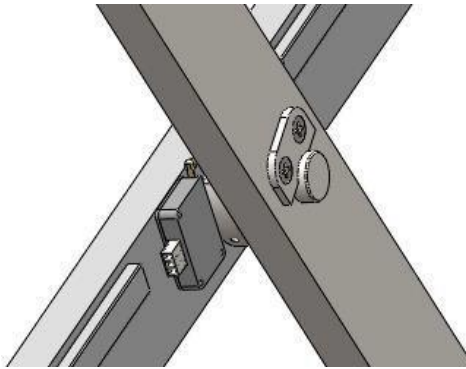

Picture 13 up limit switch

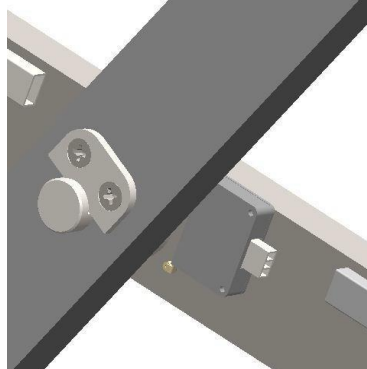

Picture 14 lower limit switch



Picture 15 Limit switch positioning

### OIL PIPE CONNECTION:

Follow the “oil pipe connection diagram” to connect the oil pipes. Only skilled and authorized personnel is allowed to perform the operations.

Pay particularly attention to the oil pipe fitting protection.

Refer to the “oil pipe diagram” while:

- connecting pipes, pay attention to the oil pipe joint protections to prevent impurities from entering the hydraulic circuit.

- connecting the oil pipes, be careful not to mistake the oil pipe reference numbers.

- In the case of a standard installation, the control unit is close to the vehicle’s entry direction. If it is positioned to the right, it is necessary to adjust also the oil pipe.



Picture 17



## CHAPTER 5: CALIBRATION



Add hydraulic oil as instructed.

After installing the lift, as required in Picture 4, and after connecting the hydraulic /electrical circuits and any other pneumatic circuits, proceed as follows:

- open the hydraulic oil tank and add 18L of hydraulic oil - type H46 - into it. The hydraulic oil is not supplied by the manufacturer.
- Make sure the hydraulic oil does not have impurities to avoid the malfunction of the solenoid valve.
- activate the "MAIN SWITCH" button to turn on the power, by clicking the 'UP' button proceed checking that the engine rotates clockwise (by looking down), if it's not turned off the "MAIN SWITCH" and then change the motor phase.



When power is switched on, the high voltage in the control box is activated. Only authorized person can do such operation.

Oil pressure adjustment:

- 1- Pressing the 'UP' button the engine starts to bring the platforms to the maximum height that can be reached.
- 2- Open the control box door and press the "UP" and "SB4" button, as shown in picture 20, for a few minutes until the all the air outflow from the hydraulic circuit.
- 3- Press the 'DOWN' button until the platforms stop at the minimum permissible height and then press the "SECOND DOWN" button, in this way the platforms will reach the closing position.
- 4- The oil pressure adjustment is now completed.

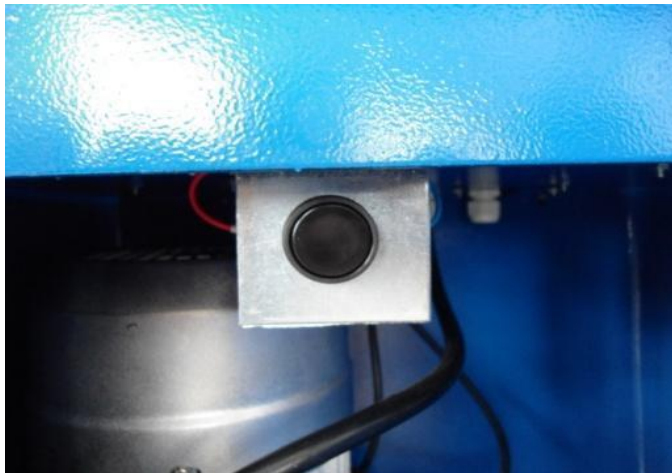

Picture 20 The level setting button (SB4)

### ANCHOR PLUG INSTALLATION:



The anchor plugs installation must be carried out simultaneously with the installation of the lift, this is to ensure the stability of the structure and a perfect seal:

- Adjust the base parallelism and the distance between the two platforms.
- Fasten the anchor plugs with a percussion electric drill, poke a 120 mm hole and clean it before inserting the dowels. (Picture 21)
- Use a rubber hammer to insert the dowels into the floor.



Picture 21

### Leveling:

- Use a level to adjust the leveling of the bases.
- If the irregularity of the platforms is due to the irregularity of the bases, use an iron thickness to level it.
- After adjusting the level, insert the anchor and use a hammer to secure it.

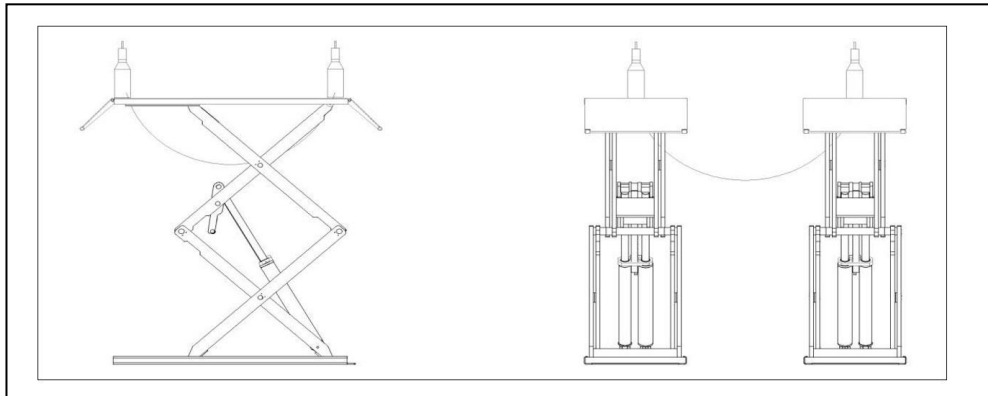

Picture 22

The gap between the base plate and the ground after the adjustment must be filled with an iron or concrete plate.

### Lift loading test:

- Switch on the machine with the "MAIN SWITCH" power button.
- Press the "UP" button and pay attention to the synchronization and to the lifting fluidity.
- Check that there is no leakage of oil.



During the test of the lift, no person, object and or material must be located near the two sides and below the lift. If an anomaly occurs, press the "EMERGENCY STOP" button to stop the lift immediately. After removing the obstacles repeat the test.

**Test of load:**

- Drive a vehicle, with a weight that does not exceed the maximum allowed lifting weight, on the platform. At this point the driver must leave the car.
- Put the rubber buffer on the platforms.
- Press the 'UP' button, lift the platforms and pay attention to the synchronization the fluidity of the lift.
- Check that there is no leakage in the hydraulic oil line.

When starting the load test no person or other things are allowed to stand below or close to any of the moving parts of the lift.



Process the test with vehicle that does not exceed the maximum permissible lifting weight. Check and make it sure that there is no leakages on the hydraulic circuit. If an anomaly occurs, press the "EMERGENCY STOP" button to stop the process immediately. Resolve the problem and repeat the test again.

**CHAPTER 6: Mode of Operation**

Check the procedure as follows.

**Operating alerts:**

- Before any operation, remove possible obstacles from the lifting area of the lift.
- When lifting or lowering the platforms, no operator is allowed to stand in the lateral side of the machine, underneath it or on both platforms.
- Avoid lifting those vehicles whose weight is above the maximum permissible lifting weight.
- When placing the vehicles on the platforms, make it sure that the body is resting on the rubber pads supplied.
- Pay attention to the synchronization of the lift. If there are anomalies, stop the lift immediately, check and resolve the problem.
- When the equipment is not going to be used for a long period of time or during the night hours lower the platforms to their full stop, remove the vehicle from the lift and stop the power supply.

**Instructions for the electronic drive: (see picture 23)**

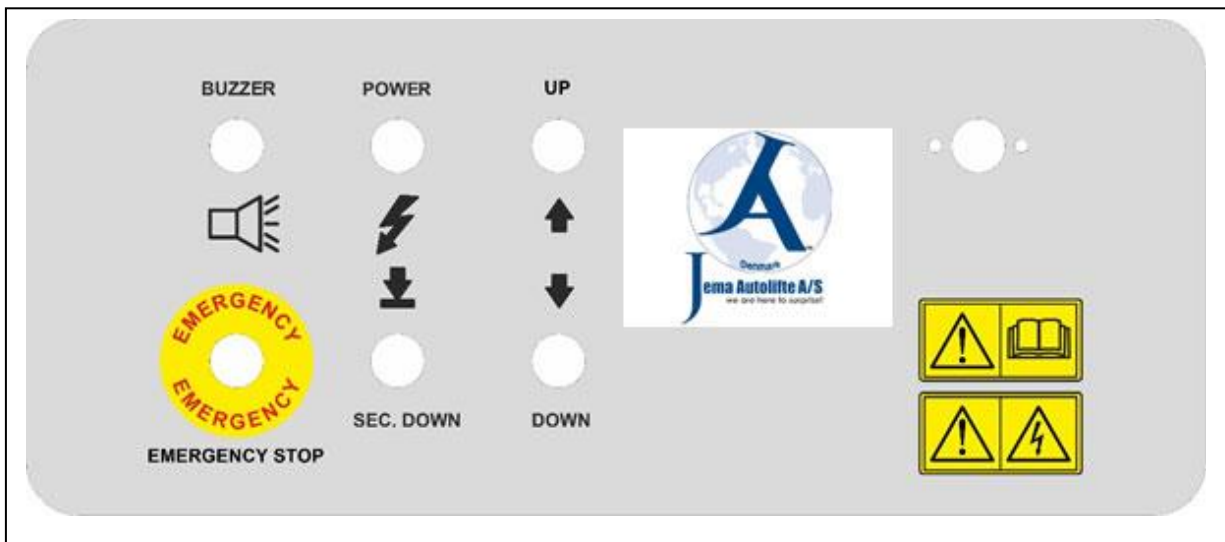

**LIFTING:**

- By Pressing the 'UP' button the platforms will rise. Platforms will stop climbing when they reach the upper limit.
- By Releasing the 'UP' button, the oil pump stops working and the platforms stop lifting.

**LOCK:**

- Press the 'SEC. DOWN' button to lock the platform when the lift is in the required position.

**DESCENT:**

- By pressing the 'DOWN' button, the platforms will begin to descend.
- By releasing the 'DOWN' button, the platforms will stop descending.
- When the "DOWN" button is kept pressed, the platforms continue to descend automatically, stopping at a high of about 330mm reaching the lower limit switch. By releasing the "DOWN" button and pressing the "SEC. DOWN" button the platforms will go down to their closing position.

**EMERGENCY STOP:**

If the lift has a malfunction while a vehicle is on the platform, press the "EMERGENCY STOP" button to stop the entire operating circuit and to interrupt any other operations.

**STOP FOR PLATFORM DISALIGNMENT:**



When the platforms are not leveled, follow the process described in the next paragraph to adjust the alignment. The lift can only be put into use after the two platforms have been placed back at the same level.

**HYDRAULIC OIL ADJUSTMENT (normal conditions of use):**

After completing the installation process, the platform P1 is lower than the P2 one, this is due to the air still present in the oil cylinder. When performing the "oil circuit setting operation", the lift must not be placed in operation and no weight have to be placed on the platform. The adjustment process is shown at page 17.



**EMERGENCY PROCEDURE FOR PLATFORM MANUAL LOWERING (POWER FAILURE):**

During the manual lowering of the platforms observe the vehicle on the deck until the operation is ended.

If anomalies occur during the process, immediately close the hydraulic circuit safety valve.

The manual lowering process take place as follow:

- Place the "MAIN SWITCH" button on the "OFF" position (do not cut off the power from the power supply).
- Open the rear door of the control box and look for the valve figure 24.
- Loosen slowly the RED final part of the oil valve.

You will notice that the platform will start to descend.

- Always check the correct floor leveling during lowering process.
- After lowering the platforms immediately tighten the lower valve screw.
- The manual lowering process is now completed.



**CHAPTER 7: MAINTENANCE AND CARE**

Maintenance operations are only allowed to personnel with adequate training.

All pins and upper/lower sliding blocks of the lift must be lubricated regularly.

Hydraulic oil should be replaced once a year.

The oil level should always reach at least the upper limit indicated.

When replacing the oil, the lifting platforms of the lift must always be in the closed position, then proceed with the extraction of the used oil.

The lift maintenance technicians must check that the pneumatic safety valve is reliable and in operation.

**CHAPTER 8: TROUBLESHOOTING**

| Symptom                                                                       | Cause                                                                          | Troubleshooting                                                                                                                                           |
|-------------------------------------------------------------------------------|--------------------------------------------------------------------------------|-----------------------------------------------------------------------------------------------------------------------------------------------------------|
| <b>The engine does not work</b>                                               | The power cable is not plugged in by the power outlet.                         | <i>Connect the power cable to the power socket.</i>                                                                                                       |
|                                                                               | The AC contactor does not work.                                                | <i>If the engine works by forcing the contactor with an isolation rod, replace the contactor.</i>                                                         |
|                                                                               | The limit switch is not closed.                                                | <i>Check the limit switch, its cable and adjust or replace the limit switch.</i>                                                                          |
| <b>In lifting operation, the motor runs, but there is no lifting movement</b> | The motor turns reverse.                                                       | <i>Modify the phases of the power cables</i>                                                                                                              |
|                                                                               | Lifting with light load works normally but not with heavy load.                | <i>The safety pressure set on the overflow valve can be increased by slightly rotating the right knob. The valve is defective and should be replaced.</i> |
|                                                                               | The amount of hydraulic oil is not enough.                                     | <i>Add hydraulic oil.</i>                                                                                                                                 |
|                                                                               | The descent valve is activated but does not work.                              | <i>Check the plug and the descent valve, check that the nut is properly sealed.</i>                                                                       |
|                                                                               | The “antiknock valve” is blocked.                                              | <i>Remove the “antiknock valve” from the oil supply hole placed at the bottom of the oil cylinder, and clean the “antiknock valve”.</i>                   |
| <b>The lift lowers very slowly when subjected to standard weight loads.</b>   | The hydraulic oil has a high viscosity, is deteriorated or frozen (in Winter). | <i>Replace the oil with an oil conforming to the operating manual.</i>                                                                                    |
|                                                                               | The “antiknock valve” is blocked.                                              | <i>Remove the “antiknock valve” from the oil supply hole placed at the bottom of the oil cylinder, clean the “antiknock valve” or replace it.</i>         |
| <b>Platform P1 and P2 are misaligned</b>                                      | The air in the hydraulic circuit has not been completely removed.              | <i>Refer to page 16 “Oil pressure adjustment Operation”.</i>                                                                                              |
|                                                                               | Oil leakages along the oil pipe or one of its joints.                          | <i>Check the hydraulic circuit and seals, then adjust the pressure and the level of the oil.</i>                                                          |
| <b>Noisy lifting and lowering</b>                                             | The lubricant is not enough.                                                   | <i>Lubricate all pins and slider parts (including piston rod) with mechanical oil.</i>                                                                    |

APPENDIX

Hydraulic hose connection diagram

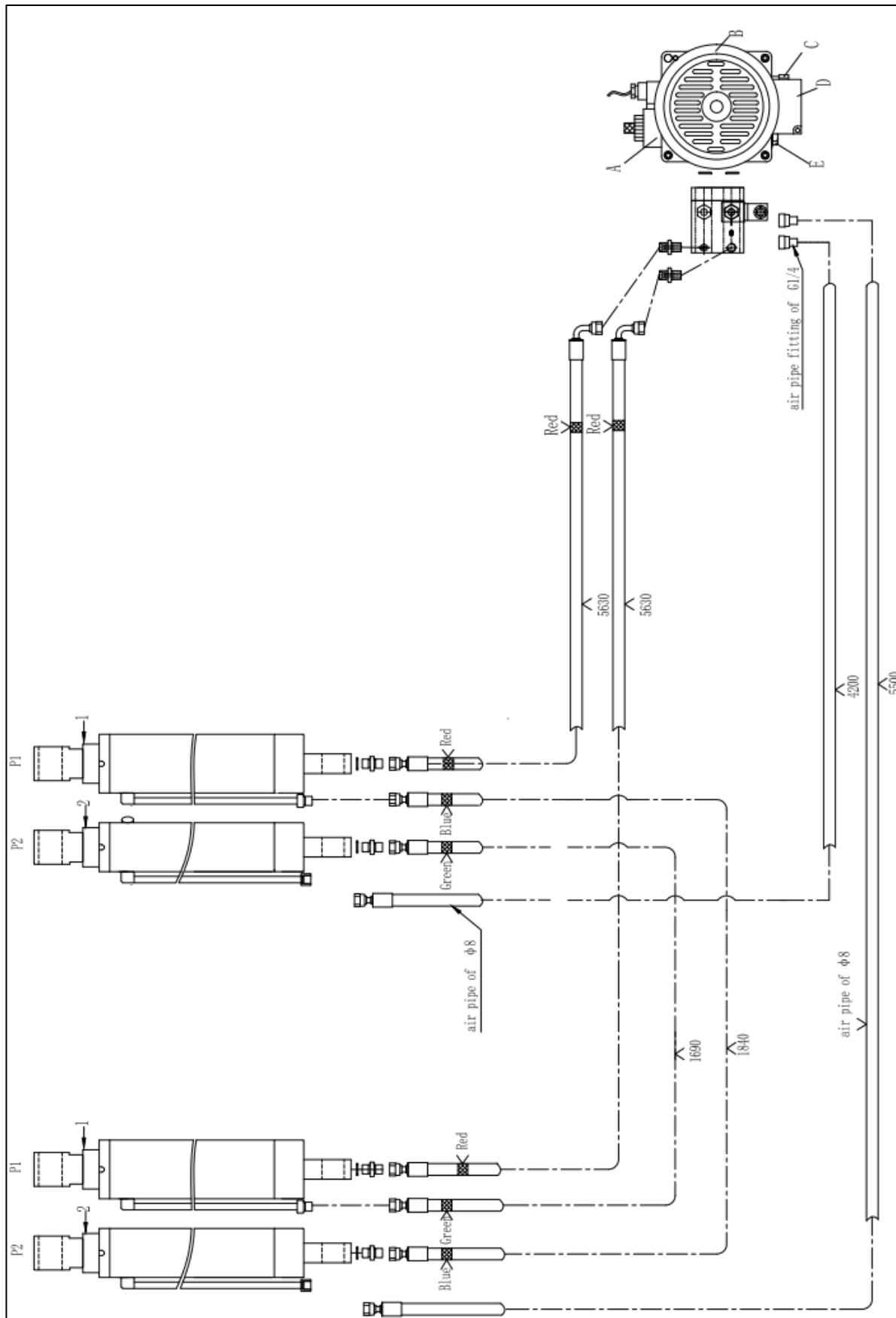

**APPENDIX**

**Hydraulic diagram (for the hydraulic lock version):**

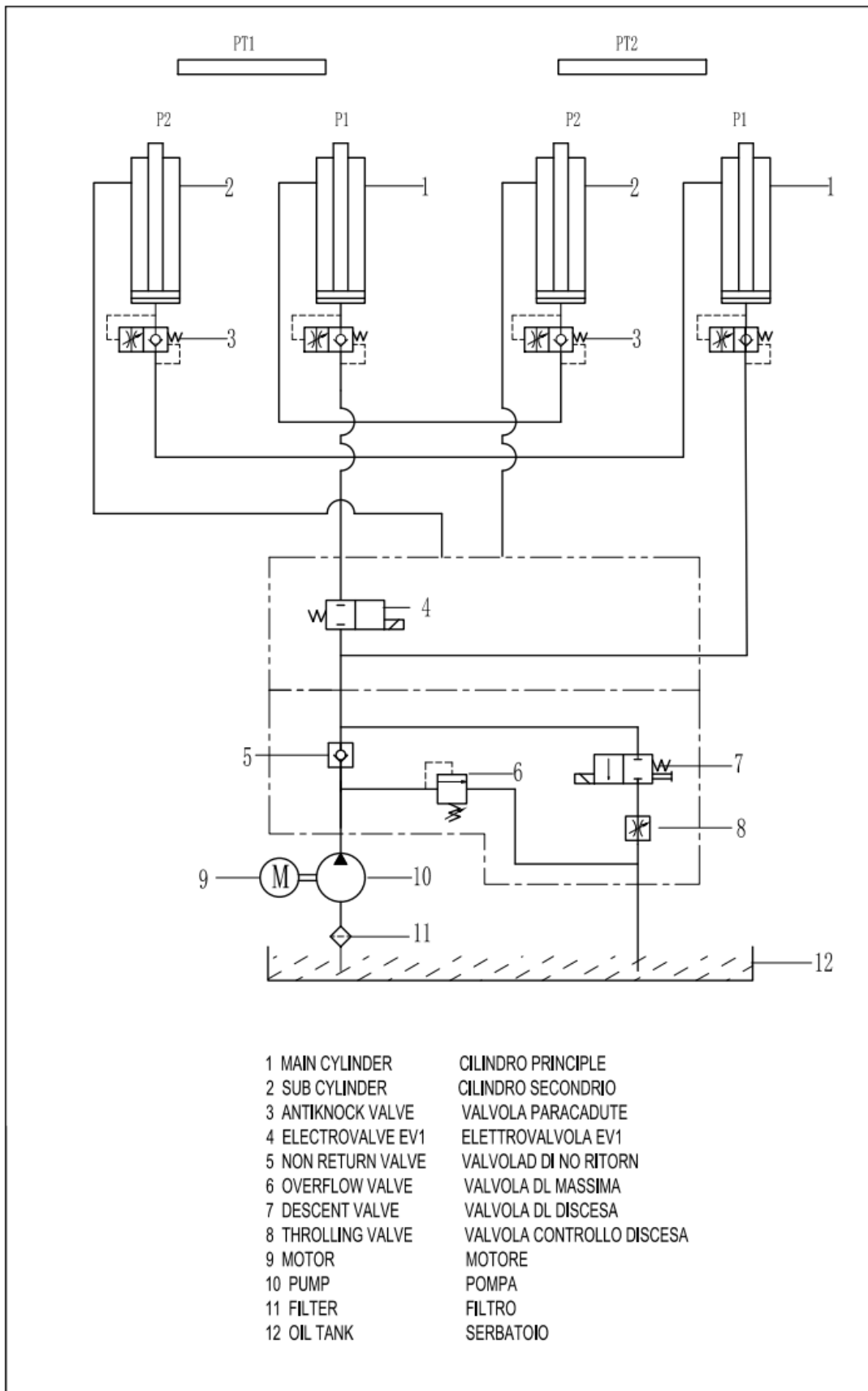

APPENDIX

Electrical diagram (400V):

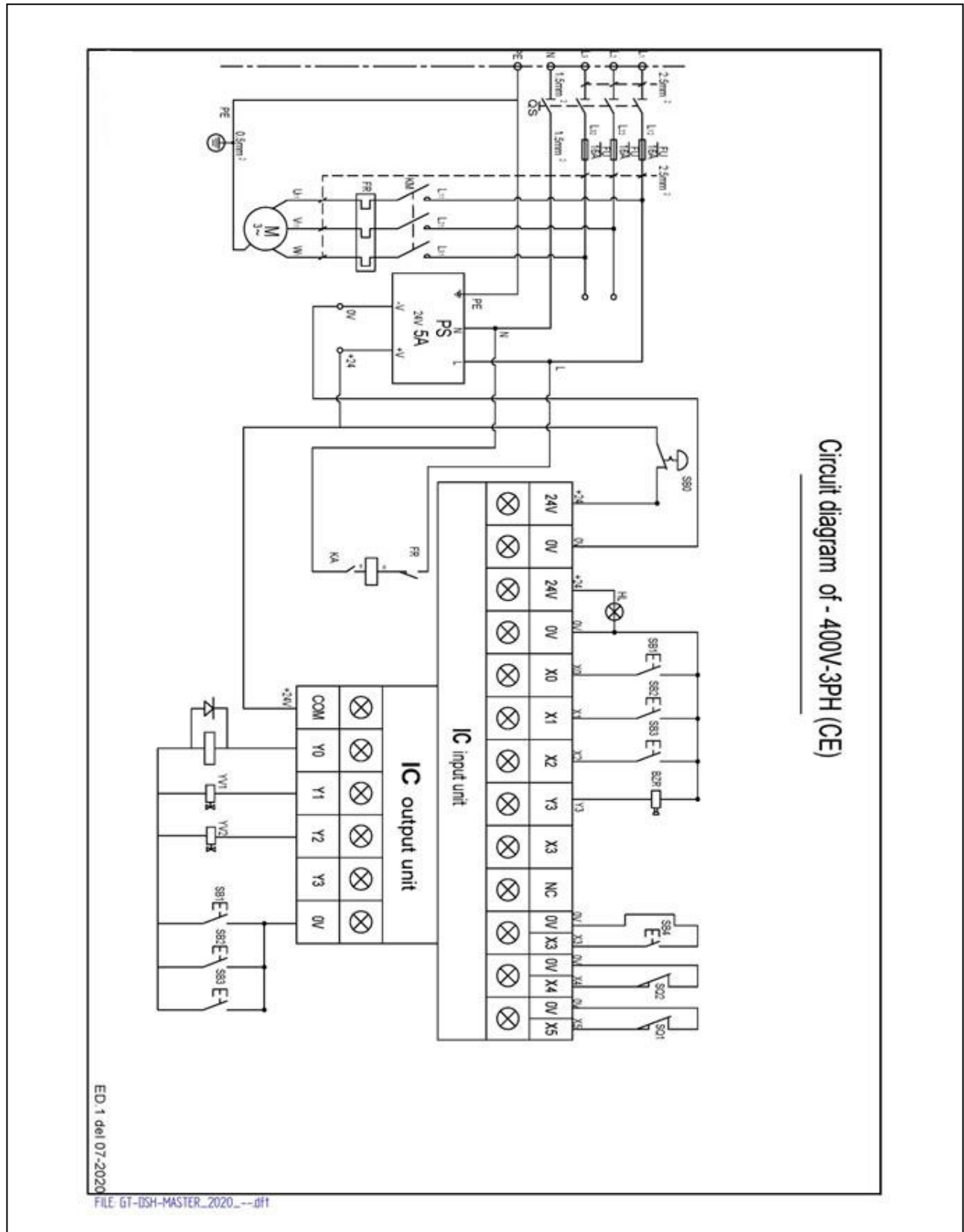



|     |                              |                 |     |                   |
|-----|------------------------------|-----------------|-----|-------------------|
| QS  | Main Switch                  | AC-23A          | 1   |                   |
| KM  | AC contactor                 | SC-03/220V      | 1   |                   |
| FR  | thermal relay                | TR-ON/3         | 1   |                   |
| M   | motor                        | ML90L 380V      | 1   | 220V optional     |
| FU  | fuse                         | 16A             | 2~3 | different voltage |
| PS  | power supply                 | 220VAC/24VDC/2A | 1   |                   |
| IC  | computer board               | 02-V14.3-20     | 1   |                   |
| HL  | power lamp                   | 24V             | 1   |                   |
| SBO | emergency                    | XB2 BS542       | 1   |                   |
| SB1 | UP button                    | IDEC            | 1   |                   |
| SB2 | DOWN button                  | IDEC            | 1   |                   |
| SB3 | SEC.DOWN button              | IDEC            | 1   |                   |
| SB4 | synchronization button       | IDEC            | 1   |                   |
| BZR | buzzer                       | AD16-22SM       | 1   |                   |
| YV1 | descent valve                | 18W-24VDC       | 1   |                   |
| YV2 | working valve                | 22W-24VDC       | 1   |                   |
| SQ1 | up limit switch of main lift | RV-166S-1C25    | 1   |                   |
| SQ2 | lower limit switch           | RV-166S-1C25    | 1   |                   |

# Jema Autolifte A/S

Industrihegnet 2

4030 Tune

Denmark

Tel. (+45) 48180300

Mail: [info@jemaautolifte.dk](mailto:info@jemaautolifte.dk)