

Assembly Instructions

Stormor Longspan Shelving

SLS20155 / SLS20205 / SLA20155 / SLA20205

Tools required:

- Hammer or Rubber Mallet.

Recommendations:

- Use a cloth or wooden block to protect components when hammering.
- Hammer gently to avoid component damage.
- Assembly is recommend with two people.

Caution:

- Wear gloves during assembly.
- Handle components with care due to possible sharp corners.
- Assemble the unit on a solid, level surface.

Parts List

Please read through all the instructions and verify that all parts are present before beginning assembly.

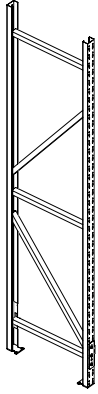

- A Upright Frames**
Starter Bay x 2
Add-on Bay x 1

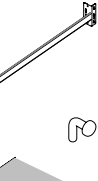

- B Beams** x 8



- C Locking Clips** x 16

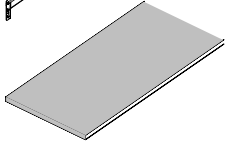

- D Steel Shelf Panels** x 8

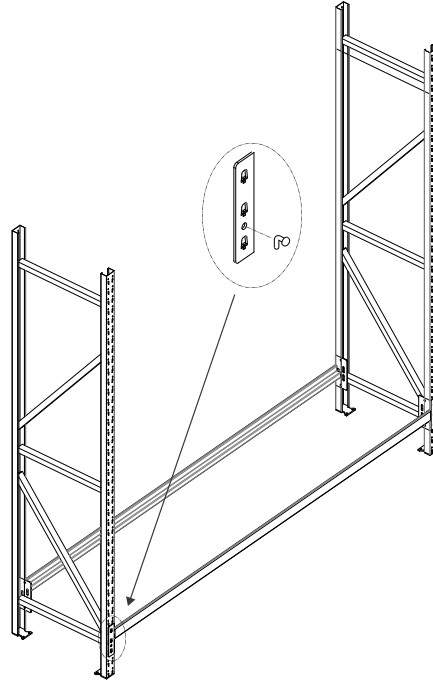

Step 1 - Attach beams to the upright frames by slotting into the V channel and pushing down. Rubber mallet can be used if required. Insert locking clips to prevent the beam from being dislodged.

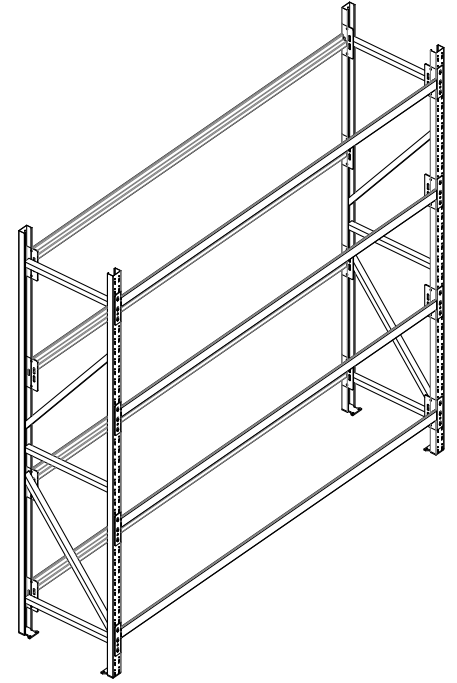

Step 2 - Attach the remaining beams at the desired shelf height.

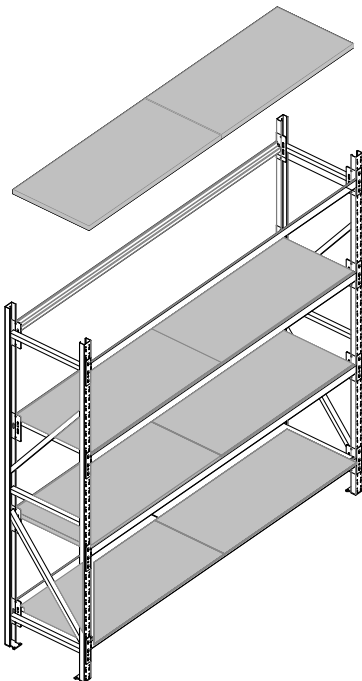

Step 3 - Insert shelf panels so they sit flush on the beams. Start at the bottom and work your way up.

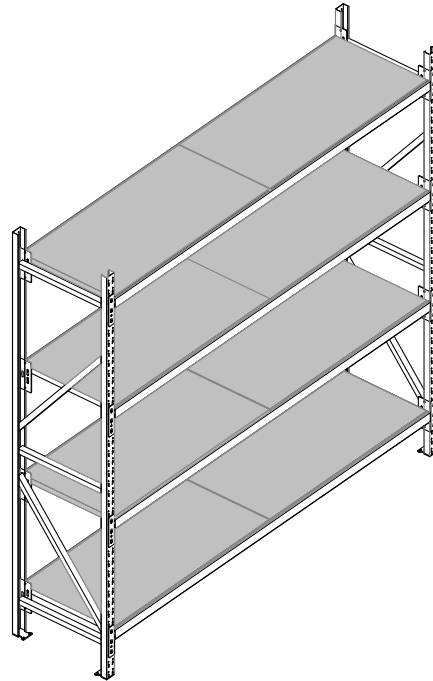

Step 4 - Move unit into place and secure. It can be bolted to the floor using the included foot plates or secured with a tether (not included).

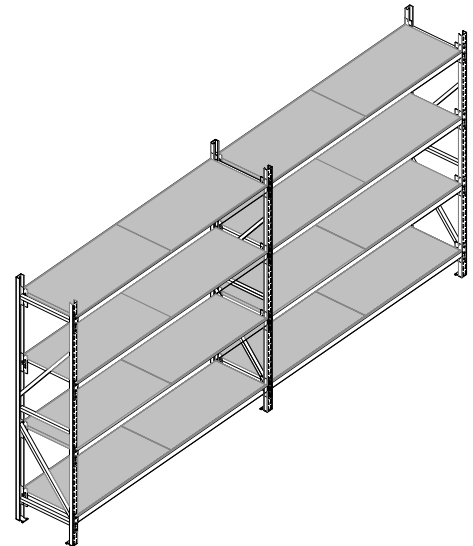

Step 5 - ** Add-on Bay only**
Add-on bays can be attached to an existing starter bay to form longer runs of shelving.