

JET PUMP

SERVICE TOOLS

Description	Part Number	Page
IMPELLER REMOVER/INSTALLER.....	529 035 956	9, 11, 16
IMPELLER SHAFT BEARING TOOL	529 036 168	13-14
IMPELLER SHAFT PUSHER.....	529 035 955	12, 14
PRESSURE CAP	529 036 283	4
PUMP PLATE.....	529 036 224	5
VACUUM/PRESSURE PUMP	529 021 800	4

SERVICE PRODUCTS

Description	Part Number	Page
CLUTCH AND PULLEY FLANGE CLEANER PRO S1.....	779244	6
JET PUMP BEARING GREASE	293 550 032	8, 14, 17
LOCTITE 243 (BLUE).....	293 800 060	12
LOCTITE 438.....	296 000 424	11
LOCTITE 518.....	293 800 038	6
LOCTITE 767 (ANTISEIZE LUBRICANT)	293 800 070	10
LUBRICANT AND ANTI-CORROSIVE (EUR)	779224	7, 10
LUBRICANT AND ANTI-CORROSIVE.....	779168	7, 10
TRIPLE-GUARD GREASE	508298	6-7, 11

Subsection XX (JET PUMP)

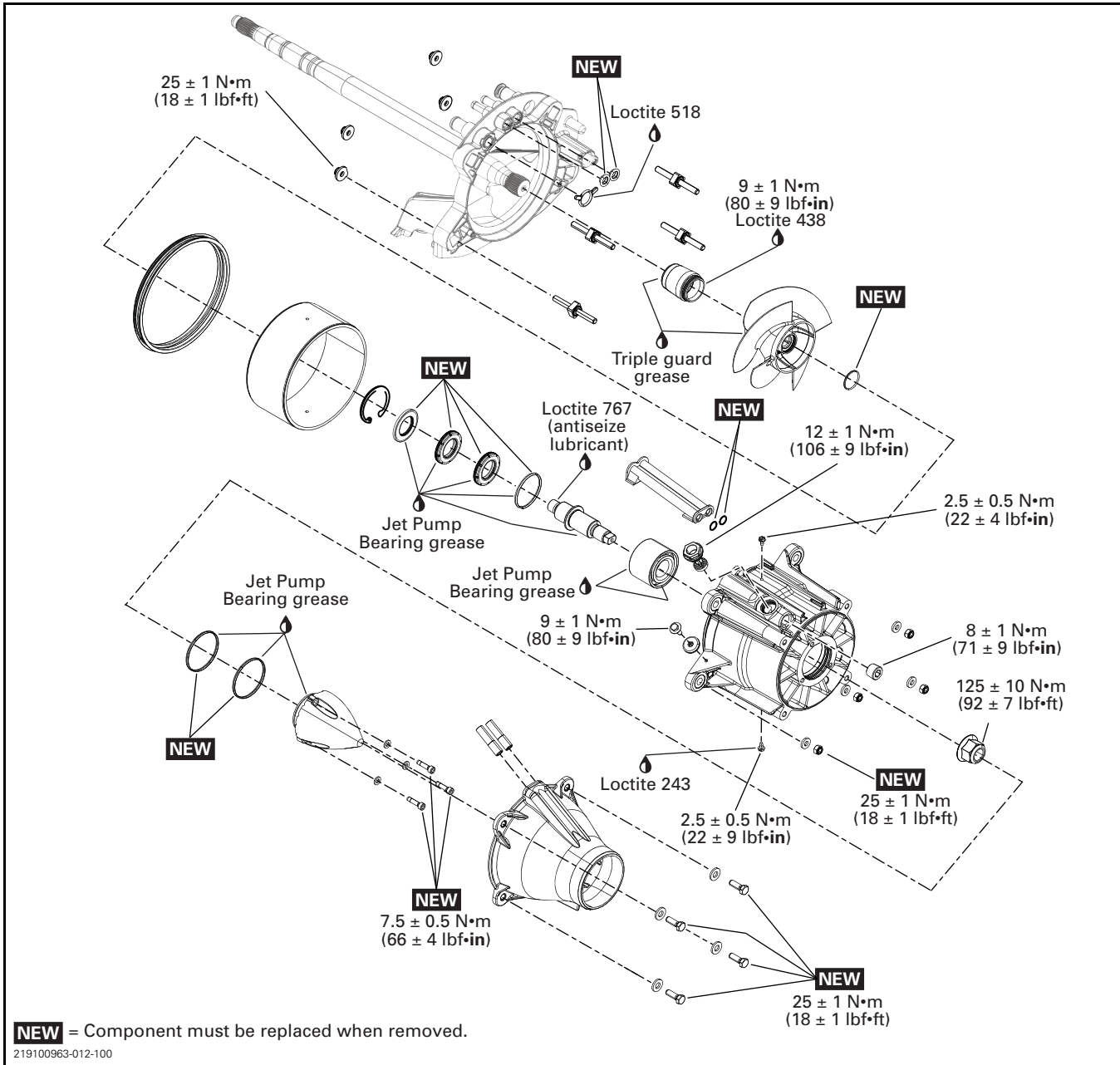

GENERAL

JET PUMP MAIN COMPONENTS

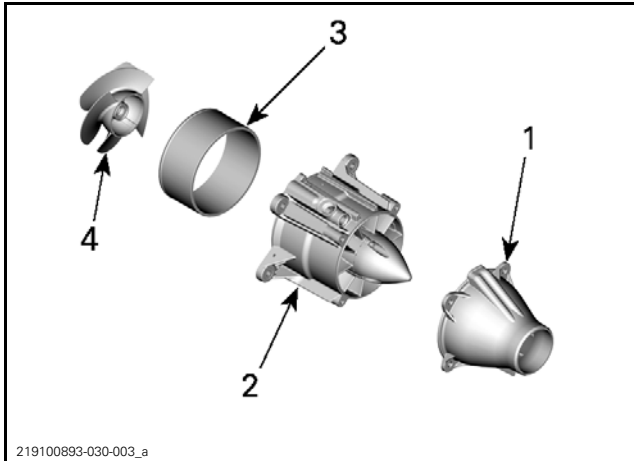

1. Venturi
2. Jet pump housing
3. Wear ring
4. Impeller

INSPECTION

IMPELLER CONDITION

Condition of impeller, impeller boot and wear ring can be quickly checked from underneath the watercraft. With the vehicle on the trailer, use a flashlight to visually inspect them through the inlet grate.

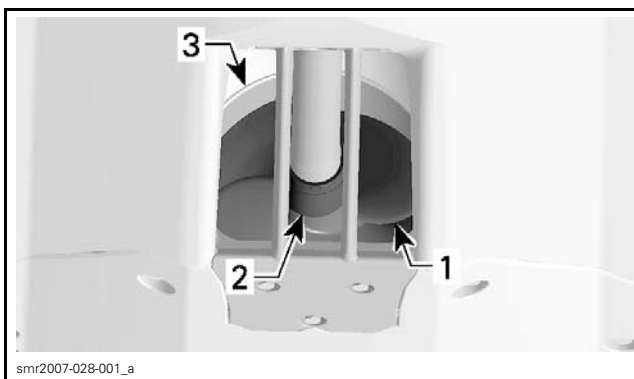

TYPICAL — UNDERNEATH HULL

1. Impeller
2. Impeller boot
3. Wear ring

IMPELLER/WEAR RING CLEARANCE

This clearance is critical for jet pump performance. To check clearance, remove jet pump.

Using a feeler gauge, measure clearance between impeller blade tip and wear ring. Measure each blade at its center.

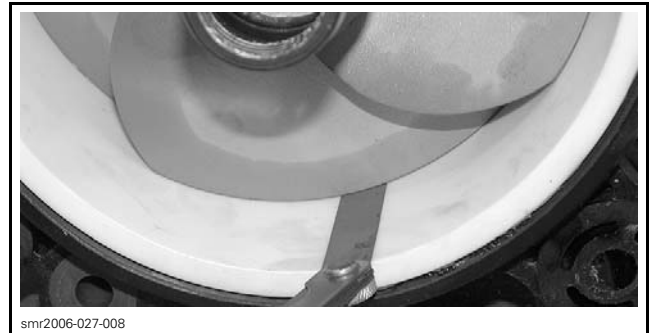

MODEL	MAXIMUM WEAR CLEARANCE
All models	0.35 mm (.014 in)

IMPELLER SHAFT RADIAL PLAY

Radial play is critical for jet pump life span.

To check radial play, remove jet pump.

Make sure impeller shaft turns freely and smoothly.

1. Retain housing in a soft jaw vise making sure not to damage housing lug.
2. Set a dial gauge and position its tip onto metal end, close to the end of the impeller hub.
3. Move shaft end up and down. Difference between highest and lowest dial gauge reading is radial play.

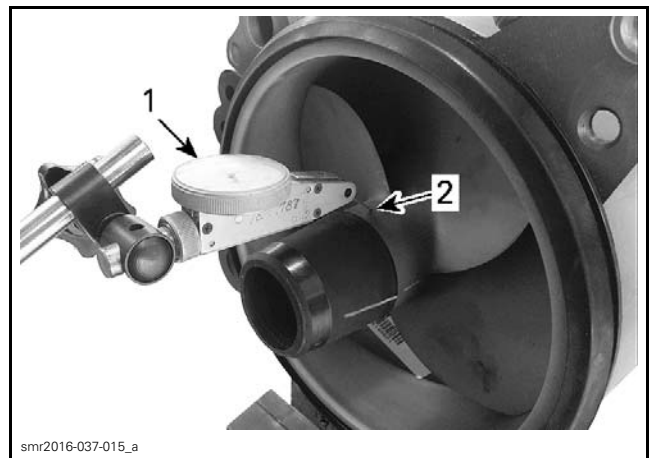

TYPICAL — MEASURING IMPELLER SHAFT RADIAL PLAY

1. Dial gauge
2. Measure close to impeller hub end

RADIAL PLAY
0.5 mm (.02 in)

Subsection XX (JET PUMP)

Excessive play can come either from worn bearing or damaged jet pump housing bearing surface.

LEAK TEST

Whenever performing any type of repair on the jet pump, a leak test should be carry out.

Proceed as follows:

1. Remove impeller cover. Refer to *IMPELLER COVER* in this subsection.
2. Install the pressure cap on pump housing.

REQUIRED TOOLS	
PRESSURE CAP (P/N 529 036 283)	
VACUUM/PRESSURE PUMP (P/N 529 021 800)	

3. Connect the vacuum/pressure pump to the pressure cap fitting.



TYPICAL

4. Pressurize pump.

LEAK TEST PRESSURE
Maximum 70 kPa (10 PSI)

5. Pump must maintain this pressure for at least 5 minutes.

NOTE: Only 2 or 3 bubbles coming out from the seal on the impeller side is acceptable. Leaks from other areas must be repaired.

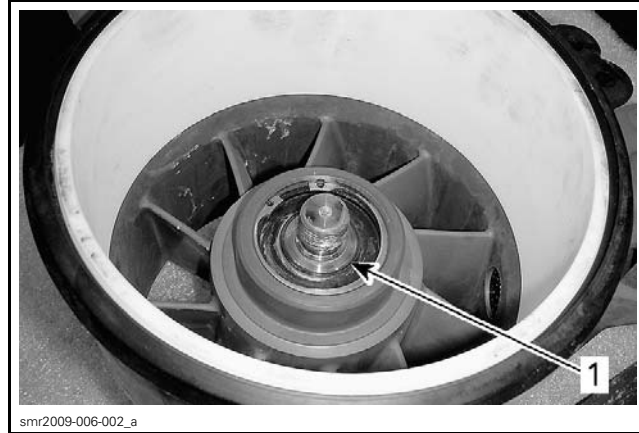

TYPICAL

1. Small leak here is acceptable

NOTICE Repair any leak. Failure to correct a leak will lead to premature wear of pump components.

6. Disconnect pump and remove pressure cap.
7. Reinstall impeller cover. Refer to *IMPELLER COVER* in this subsection.

PROCEDURES

NOTE: Whenever removing a part, visually check for damage such as: corrosion, cracks, split, break, porosity, cavitation, deformation, distortion, heating discoloration, wear pattern, defective plating, missing or broken balls in ball bearing, water damage diagnosed by black-colored spots on metal parts, etc. Replace any damaged parts. As a quick check, manually feel clearance and end play, where applicable, to detect excessive wear.

SACRIFICIAL ANODES

Inspecting the Sacrificial Anodes

Check for wear. If worn more than half, replace anode.

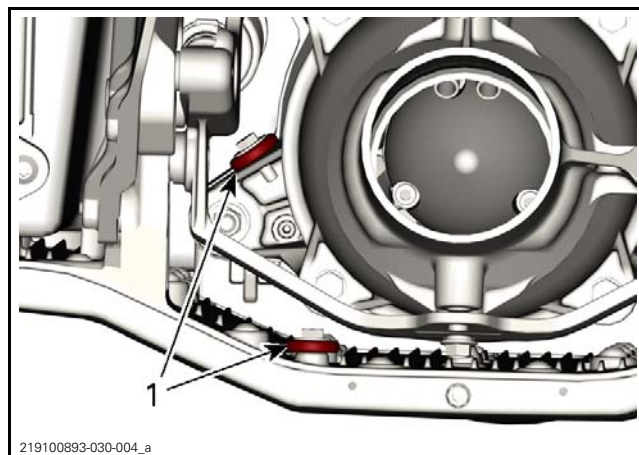

1. Sacrificial anode location

Removing the Sacrificial Anode

Remove and discard screw and anode.

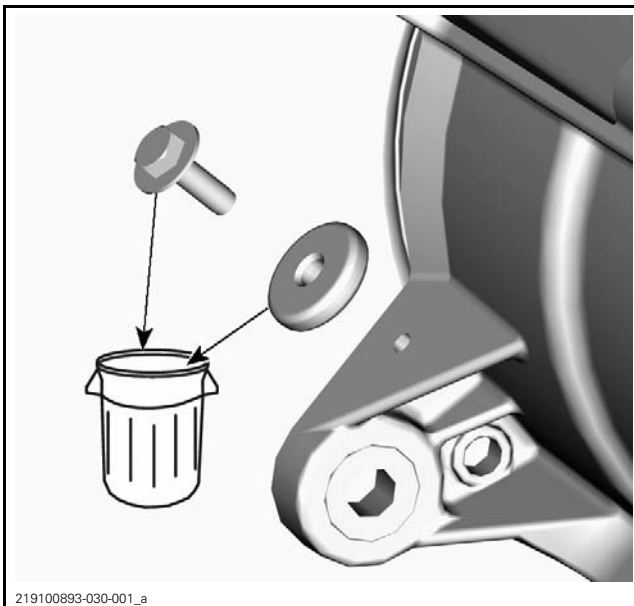
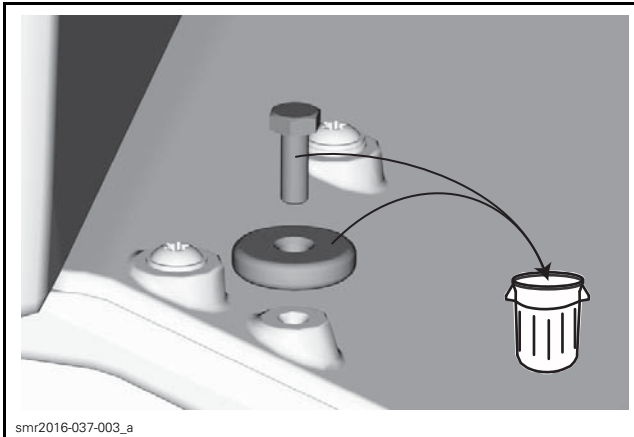

Installing the Sacrificial Anode

Installation is the reverse of the removal procedure.

TIGHTENING TORQUE	
Sacrificial anode screw	8 N•m ± 1 N•m (71 lbf•in ± 9 lbf•in)

VENTURI

Removing the Venturi

1. Remove the iBR gate, VTS trim ring and nozzle. Refer to *iBR, REVERSE AND VTS* subsection.
2. Remove the venturi from the jet pump housing.

Installing the Venturi

The installation is the reverse of the removal procedure.

TIGHTENING TORQUE	
Venturi retaining screw	25 N•m ± 1 N•m (18 lbf•ft ± 1 lbf•ft)

JET PUMP HOUSING

Removing the Jet Pump Housing

1. Remove the iBR gate, VTS trim ring and nozzle. Refer to *iBR, REVERSE AND VTS* subsection.
2. Remove the venturi.
3. Remove and discard the nuts that retain the jet pump to the pump support.

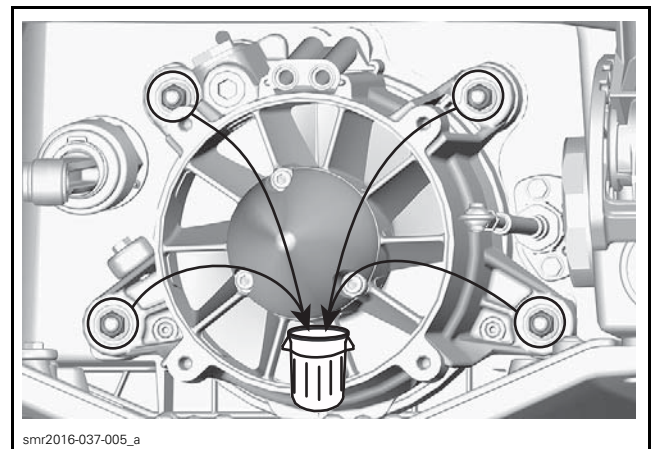

4. Pull back jet pump housing to remove it from the pump support. It may be necessary to wiggle it slightly as you pull back on the pump.

Temporarily fasten the engine alignment plate to pump support to support drive shaft and avoid PTO oil seal damage.

REQUIRED TOOLS	
PUMP PLATE (P/N 529 036 224)	

Inspecting and Cleaning the Jet Pump Housing

1. Visually inspect jet pump housing. Pay attention to the stator. Ensure the assembly is clean and free of any debris and defects. Do the following as applicable.
2. Blow low pressure compressed air through the pressure outlet fitting and make sure it is clear.

Subsection XX (JET PUMP)

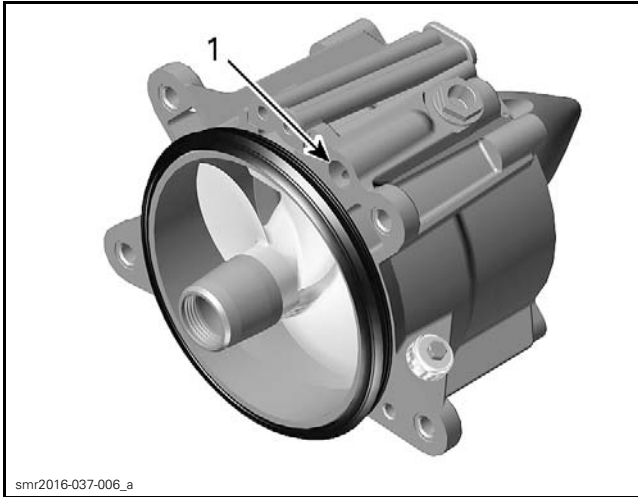

1. Pressure outlet

3. Ensure cap screw is tight.
4. Ensure the neoprene seal is in good condition. Replace as required.

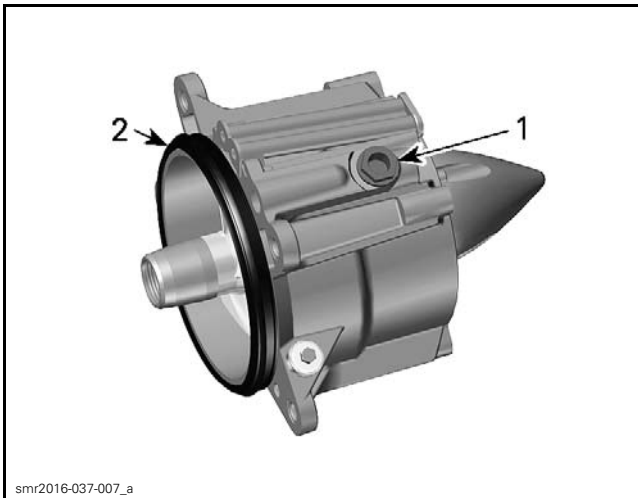

1. Cap screw
2. Neoprene seal

Installing the Jet Pump Housing

The installation is the reverse of the removal procedure. However, pay attention to the following.

Clean impeller splines and drive shaft splines with Clutch and pulley flange cleaner or equivalent. Splines must be free of any residue.

NOTICE To avoid damaging the drive shaft finish, never use a metallic brush.

Lubricate drive shaft splines, impeller splines and the inside of the impeller boot with grease.

SERVICE PRODUCTS
CLUTCH AND PULLEY FLANGE CLEANER PRO S1 (P/N 779244)
TRIPLE-GUARD GREASE (P/N 508298)

Ensure the neoprene seal is properly installed on the jet pump.

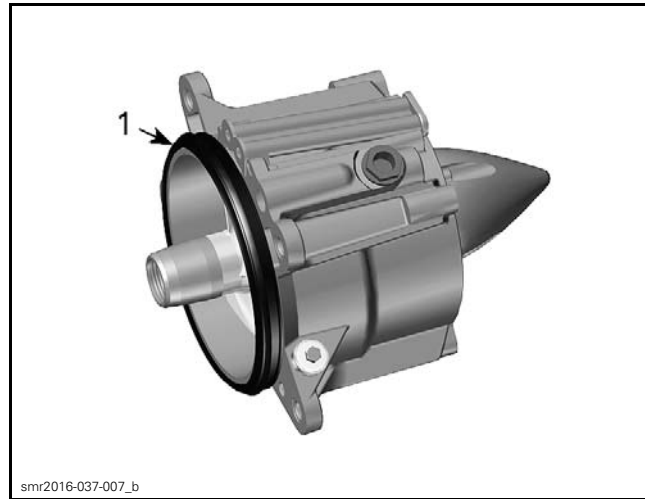

1. Neoprene seal

Install new O-rings then slide water outlet adapter onto pump.

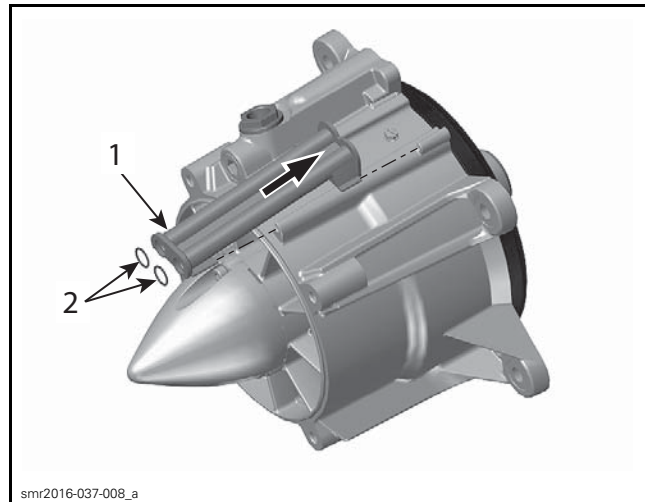

1. Slide adapter onto pump
2. New O-rings here

Install new O-rings on pump support.

Apply a thin layer of Loctite on the rounded portion of the O-rings to hold it against the support.

SERVICE PRODUCTS
LOCTITE 518 (P/N 293 800 038)

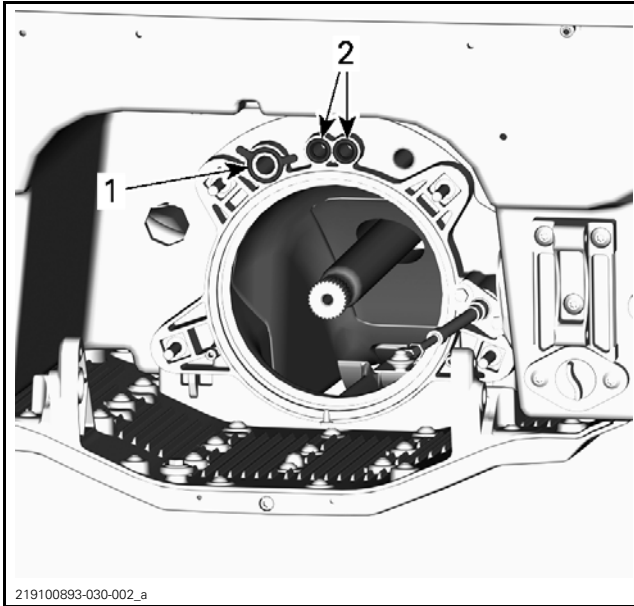

1. Install new O-rings
2. O-rings (with tabs)

Generously apply grease on drive shaft splines.

SERVICE PRODUCTS	
TRIPLE-GUARD GREASE (P/N 508298)	

Install jet pump.

NOTE: If necessary, wiggle jet pump to engage drive shaft splines in impeller.

Install new nuts and tighten as per table and the illustrated sequence.

TIGHTENING TORQUE	
Jet pump nuts	27 N•m ± 1 N•m (20 lbf•ft ± 1 lbf•ft)

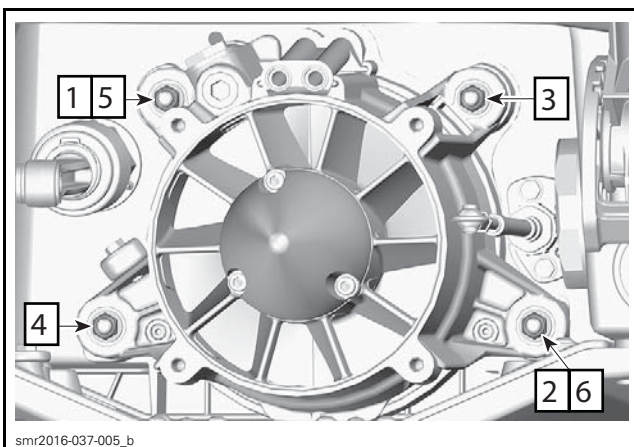

Slightly lubricate wear ring with Lubricant and anti-corrosive to minimize friction during initial impeller start.

SERVICE PRODUCTS	
Scandinavia	LUBRICANT AND ANTI-CORROSIVE (EUR) (P/N 779224)
All other countries	LUBRICANT AND ANTI-CORROSIVE (P/N 779168)

IMPELLER COVER

Removing the Impeller Cover

1. Remove the jet pump housing.
2. With pump housing in vertical position, remove and discard the 3 retaining screws.

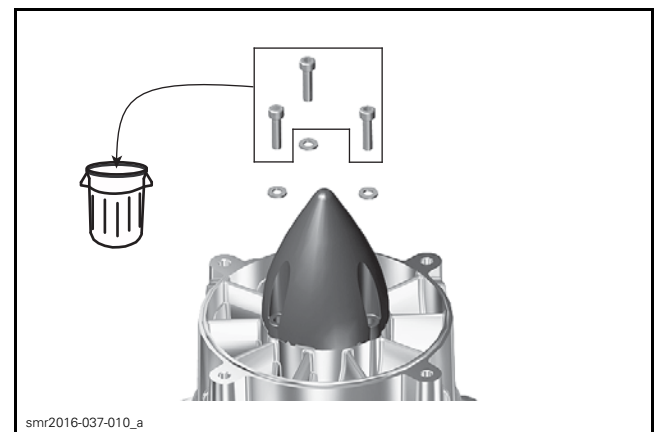

3. Using a fiber hammer, gently tap impeller cover to help release it from the jet pump housing.
4. Use a flat screwdriver in the slots provided as pry points to remove it from the jet pump housing.

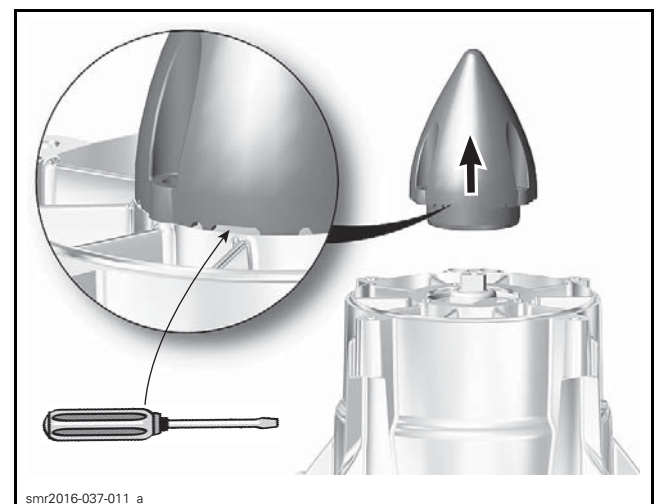

5. Remove both cover O-rings.

Subsection XX (JET PUMP)



1. Cover O-rings

Inspecting the Impeller Cover

Check for presence of water in cover and bearing area. If water is found, replace seals on impeller side. Also replace O-rings and/or impeller cover.

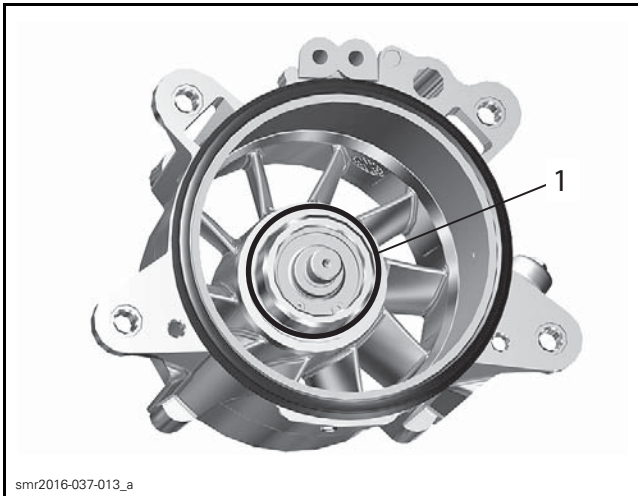

1. Seal on impeller side

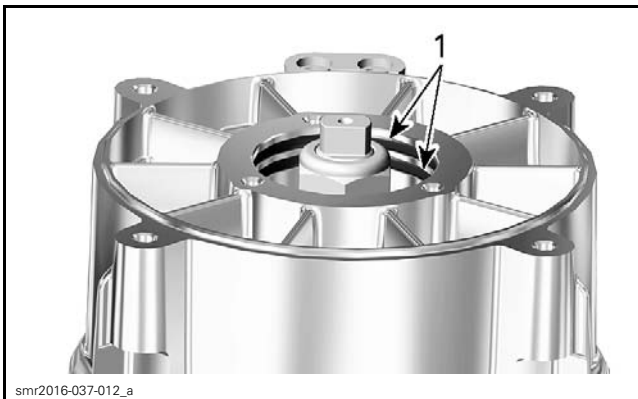

1. Cover O-rings

Check impeller boot and O-rings condition on impeller. Replace as required.

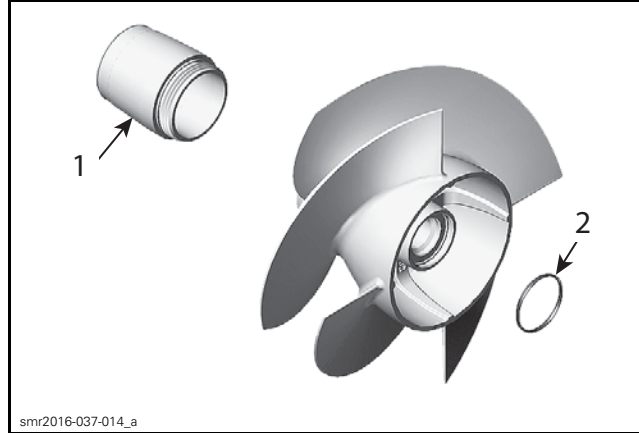

1. Impeller boot
2. Impeller O-ring

Perform a leak test. Refer to *LEAK TEST* in this subsection.

Installing the Impeller Cover

1. Apply a thin layer of grease in O-ring grooves.

SERVICE PRODUCTS
JET PUMP BEARING GREASE (P/N 293 550 032)

2. Install O-rings in their respective groove and make sure they are properly lubricated.

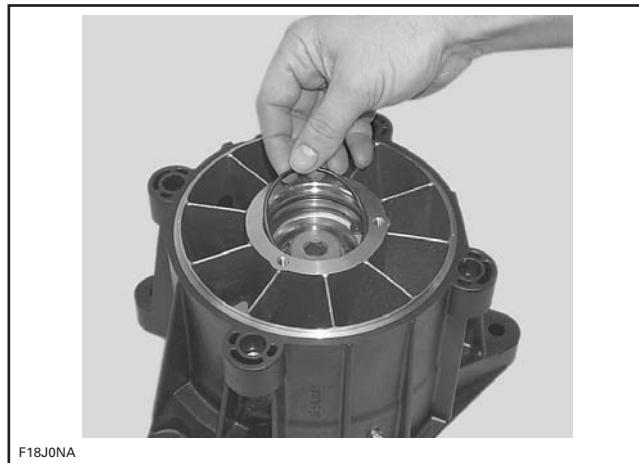

TYPICAL

3. Install impeller cover by aligning the cover index mark with the pump top fin as shown.

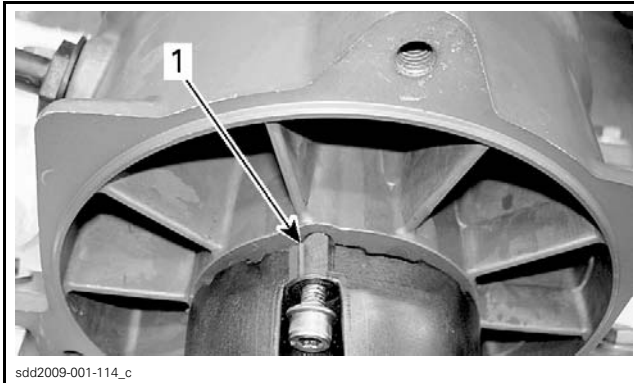

1. Align mark with top fin

NOTE: Cover can only be installed in one position as screw holes are not located symmetrically.

4. Secure cover with **NEW** self-locking screws.

NOTE: Push cover against pump housing while alternately tightening screws. Make sure O-rings are positioned correctly and they are not damaged when pushing the cover.

TIGHTENING TORQUE	
Cover screw	7.5 N•m ± 0.5 N•m (66 lbf•in ± 4 lbf•in)

IMPELLER

Removing the Impeller

NOTE: If impeller shaft is to be disassembled, loosen the impeller shaft nut prior to removing the impeller.

1. Remove jet pump housing. Refer to *JET PUMP HOUSING* in this subsection.
2. Remove impeller cover. Refer to *IMPELLER COVER* in this subsection.
3. Remove impeller boot by turning it **clockwise** (LH threads).

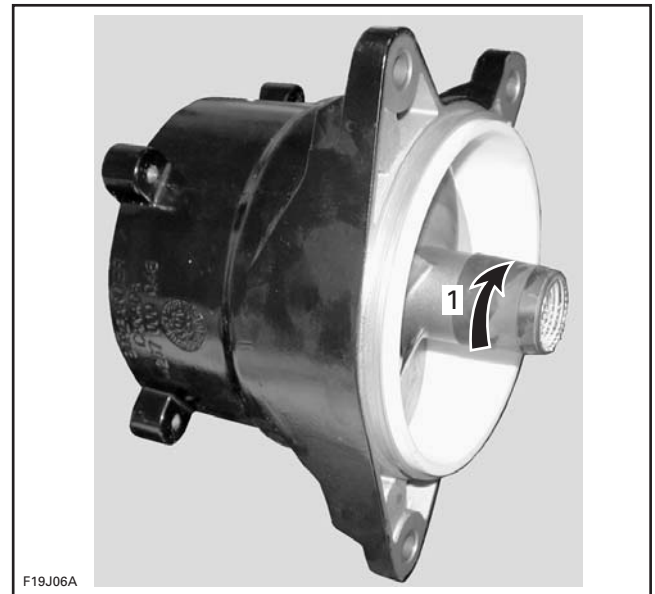

TYPICAL
1. Unscrew clockwise

4. Mount the flat sides of impeller shaft in a vise.

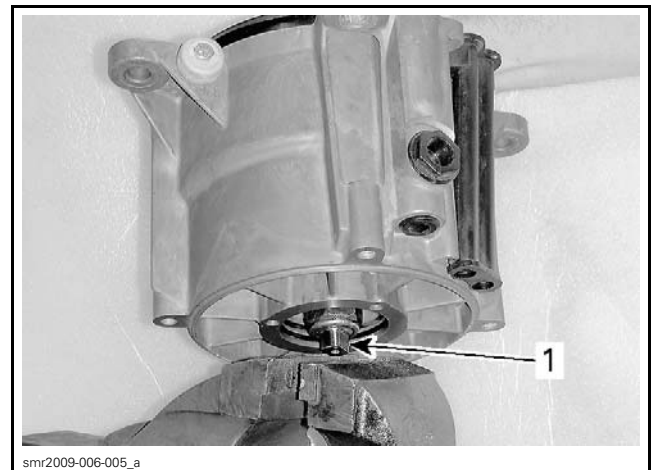

TYPICAL
1. Flat side

5. Unscrew the impeller counterclockwise using the required tool.

REQUIRED TOOL	
IMPELLER REMOVER/INSTALLER (P/N 529 035 956)	

NOTICE Never use an impact wrench to loosen impeller.

Subsection XX (JET PUMP)

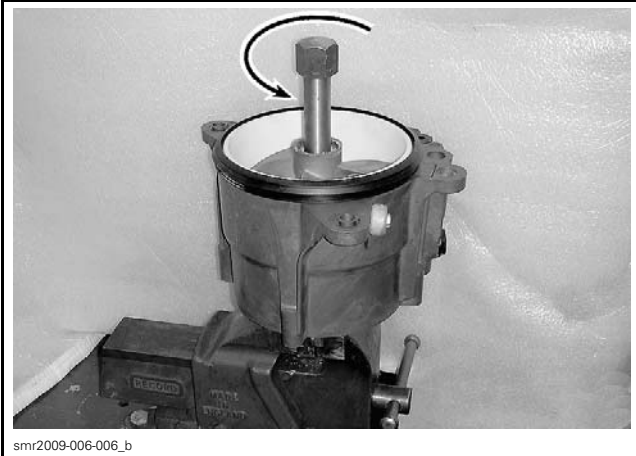

smr2009-006-006_b

TYPICAL

- To pull impeller out of the pump, apply a rotating movement as you pull on the impeller.

Installing the Impeller

- Mount the flat sides of the impeller shaft in a vise.

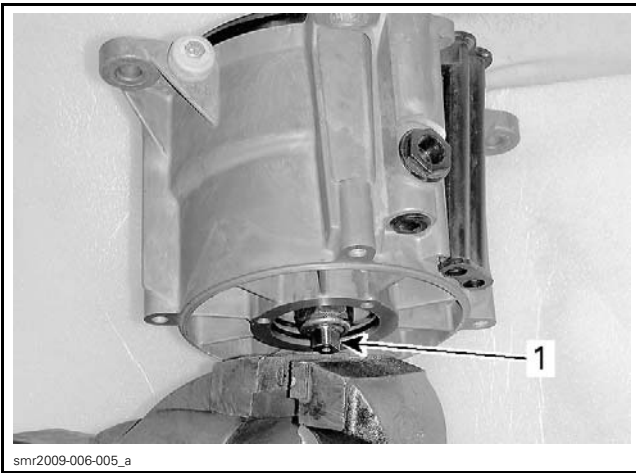

smr2009-006-005_a

TYPICAL

- Flat side

- Apply antiseize lubricant on threads of impeller shaft.

SERVICE PRODUCTS

LOCTITE 767 (ANTISEIZE LUBRICANT)
(P/N 293 800 070)



smr2009-006-002_b

TYPICAL

- Antiseize lubricant

- Apply Lubricant and anti-corrosive on the wear ring surface.

SERVICE PRODUCTS

Scandinavia	LUBRICANT AND ANTI-CORROSIVE (EUR) (P/N 779224)
All other countries	LUBRICANT AND ANTI-CORROSIVE (P/N 779168)



smr2009-006-002_c

TYPICAL

- Spray XPS lube on this surface

- Start screwing the impeller on its shaft.



smr2009-006-007

TYPICAL

5. Mount the required tool in impeller splines.

REQUIRED TOOL	
IMPELLER REMOVER/INSTALLER (P/N 529 035 956)	

6. Tighten impeller to specification.

NOTICE Never use an impact wrench to tighten impeller shaft.

TIGHTENING TORQUE	
Impeller	$125 \text{ N}\cdot\text{m} \pm 10 \text{ N}\cdot\text{m}$ $(92 \text{ lbf}\cdot\text{ft} \pm 7 \text{ lbf}\cdot\text{ft})$

Remove tool.

7. Apply Loctite on impeller boot threads.

8. Apply grease inside impeller boot.

SERVICE PRODUCTS	
LOCTITE 438 (P/N 296 000 424)	
TRIPLE-GUARD GREASE (P/N 508298)	

9. Install impeller boot on impeller and tighten counterclockwise.

WEAR RING

Inspecting the Wear Ring

Check wear ring for:

- Deep scratches
- Irregular surface
- Any apparent damage.

Check *IMPELLER/WEAR RING CLEARANCE*, see procedure at the beginning of this subsection.

Removing the Wear Ring

1. Remove jet pump housing. Refer to *JET PUMP HOUSING* in this subsection.
2. Remove impeller, refer to *IMPELLER* in this subsection.
3. **On models equipped with the 300 engine**, remove screws securing the wear ring.

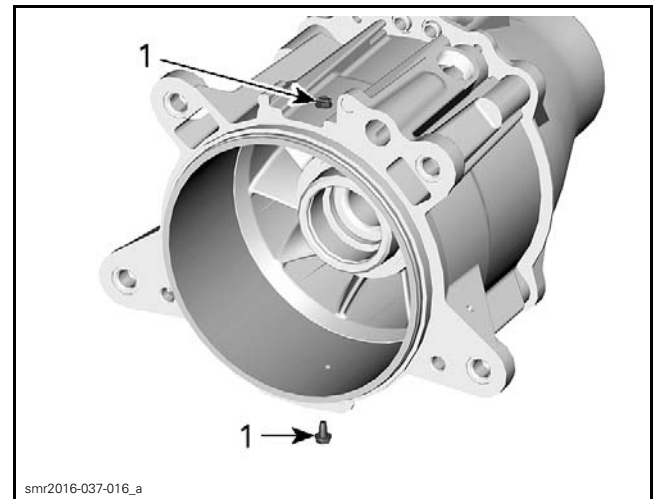

smr2016-037-016_a

1. Wear ring screws

Two methods can be used to remove the wear ring, use the most appropriate as your situation.

Method Using a Freezer

1. Place the jet pump housing and the new wear ring in a freezer for approximately 1-1/2 hour at -10°C (14°F).
2. Remove the housing from the freezer and pull the wear ring out.

NOTE: The freezer method will help but the 300 wear ring will not come completely loose using this method.

Method by Cutting the Wear Ring

1. Place jet pump housing in a vise with soft jaws. It is best to clamp housing using a lower ear.
2. Cut wear ring at two places.

NOTICE When cutting ring, be careful not to damage jet pump housing.

NOTE: Wear ring can be cut using a jigsaw, a small grinder or a low clearance hacksaw.

3. After cutting ring, insert a screwdriver blade between jet pump housing and ring outside diameter.
4. Push ring so that it can collapse internally.
5. Pull ring out.

Subsection XX (JET PUMP)

Installing the Wear Ring

Like the removing procedure, two methods can be used to install the wear ring, use the most appropriate as your situation.

Method Using a Freezer

While the housing is still cold, insert the new wear ring (previously placed in the freezer) in the housing.

On models equipped with the 300 engine, the wear ring must be secured by screws. Drill pilot holes in the wear ring using a #24 drill bit (5/32 in) and apply blue Loctite on screw threads.

SERVICE PRODUCTS	
LOCTITE 243 (BLUE) (P/N 293 800 060)	
TIGHTENING TORQUE	
Wear ring screws	2.5 N•m ± 0.5 N•m (22 lbf•in ± 4 lbf•in)

Method Using a Press

To install wear ring in housing, use a square steel plate of approximately 180 x 180 mm x 6 mm thick (7 x 7 in x 1/4 in) and a press.

Manually engage ring in housing making sure it is equally inserted all around. Press ring until it seats into bottom of housing.

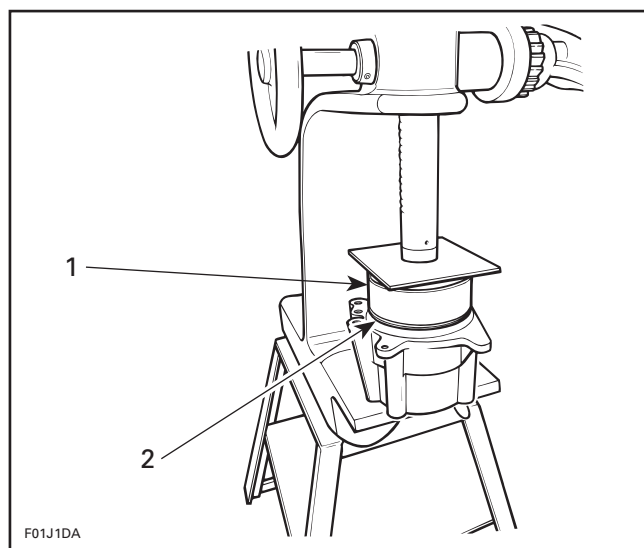

1. Rounded edge
2. Press wear ring

On models equipped with the 300 engine, the wear ring must be secured by screws. Drill pilot holes in the wear ring using a #24 drill bit (5/32 in) and apply blue Loctite on screw threads.

SERVICE PRODUCTS	
LOCTITE 243 (BLUE) (P/N 293 800 060)	
TIGHTENING TORQUE	
Wear ring screws	2.5 N•m ± 0.5 N•m (22 lbf•in ± 4 lbf•in)

IMPELLER SHAFT, BEARING AND SEALS

Removing the Impeller Shaft, Bearing and Seals

Removing the Shaft

1. Remove impeller. Refer to *IMPELLER* in this subsection.
2. Use the impeller shaft pusher tool to press impeller shaft out of pump housing.

REQUIRED TOOL	
IMPELLER SHAFT PUSHER (P/N 529 035 955)	

NOTE: Bearing will come out with the impeller shaft.

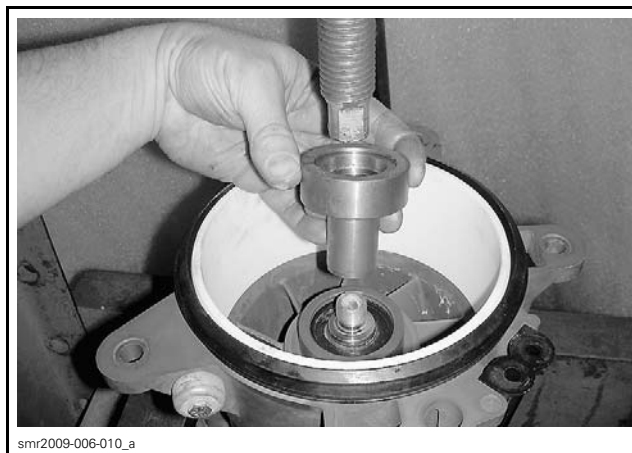

TYPICAL



TYPICAL

Removing the Bearing

1. Remove the bearing retaining nut.
2. Use the Impeller shaft bearing tool to press bearing off impeller shaft.

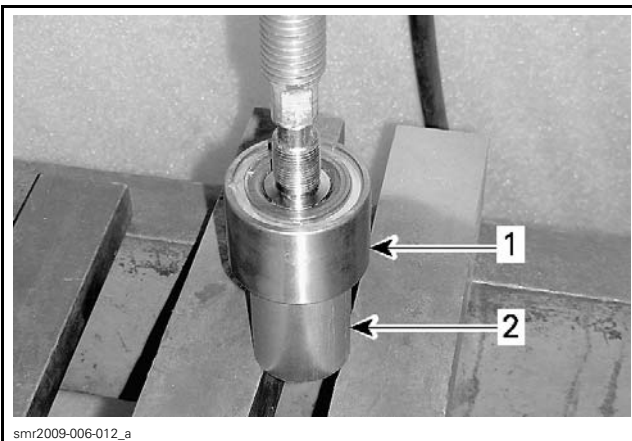
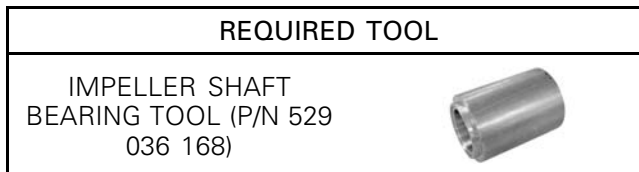

TYPICAL

1. Impeller shaft and bearing
2. Bearing tool on INNER race

Removing The Seals

1. Remove and discard the circlip securing the seals.

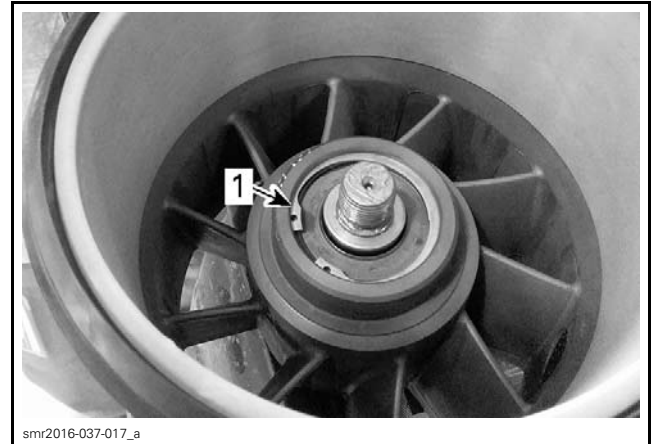

1. Circlip

2. Using an appropriate tool, press seals out of the housing.

Inspecting the Impeller Shaft and its Bearing

With your finger nail, feel seal lip contact surface on shaft. If any irregular surface is found, replace shaft and seals.

Check condition of shaft threads.

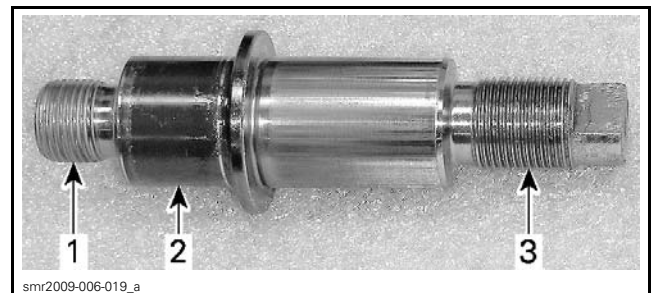

TYPICAL

1. Threads
2. Seal lip contact surface
3. Threads

Inspect ball bearing for corrosion.

Installing the Impeller Shaft, Bearing and Seals

Installing the Bearing

The installation is essentially the reverse of the removal procedure. However, pay attention to the following.

1. Using the Impeller shaft bearing tool on the bearing inner race, press the bearing on the impeller shaft.

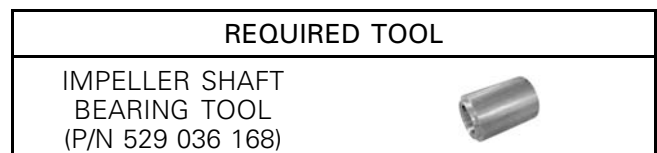

Subsection XX (JET PUMP)

- Use the Impeller shaft pusher tool to protect the impeller shaft threads.

REQUIRED TOOL	
IMPELLER SHAFT PUSHER (P/N 529 035 955)	

NOTE: The bearing can be installed in either direction.

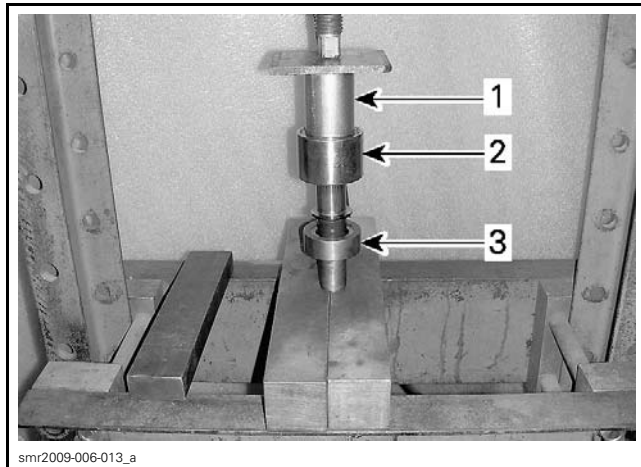

TYPICAL

- Impeller shaft bearing tool on INNER race
- Impeller shaft and bearing
- Impeller shaft installer/pusher tool

- Press bearing until it bottoms.

Installing the Impeller Shaft and Seals

NOTE: Ensure there is no O-ring in pump housing on the cover side.

- From the outlet side of pump, press impeller shaft assembly into housing using the Impeller shaft bearing tool.

REQUIRED TOOL	
IMPELLER SHAFT BEARING TOOL (P/N 529 036 168)	

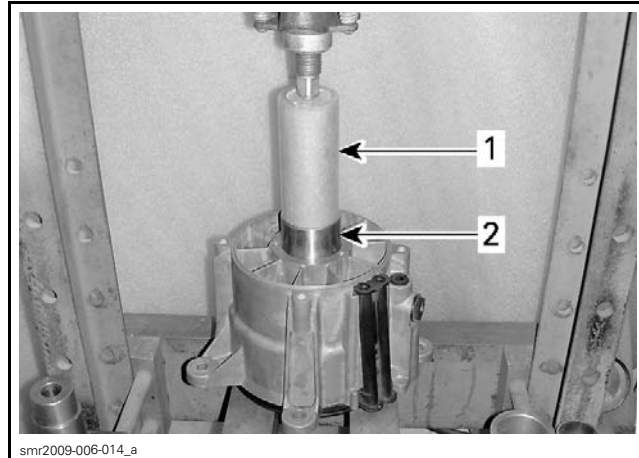

TYPICAL

- Bearing tool
- Impeller shaft and bearing

- Press bearing until it bottoms.

NOTE: Ensure impeller shaft turns freely and smoothly.

- Turn pump upside down.
- Coat shaft surface and O-ring with grease.

SERVICE PRODUCTS
JET PUMP BEARING GREASE (P/N 293 550 032)

- Install greased O-ring at bottom.

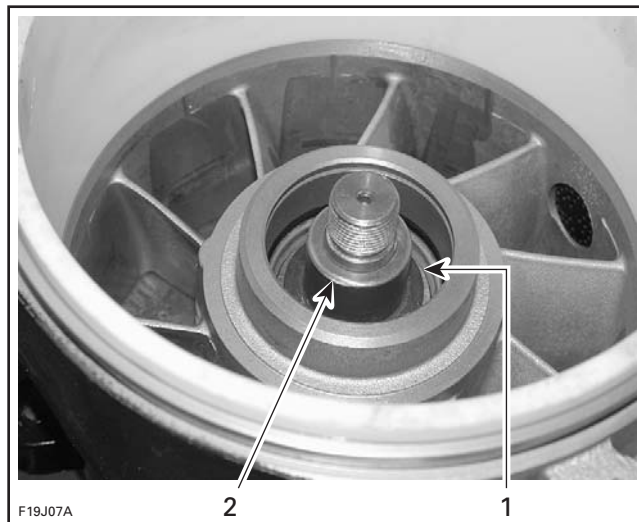

TYPICAL

- O-ring at bottom
- Coat surface

- Apply 5 g (.2 oz) of grease on bearing.

SERVICE PRODUCTS
JET PUMP BEARING GREASE (P/N 293 550 032)

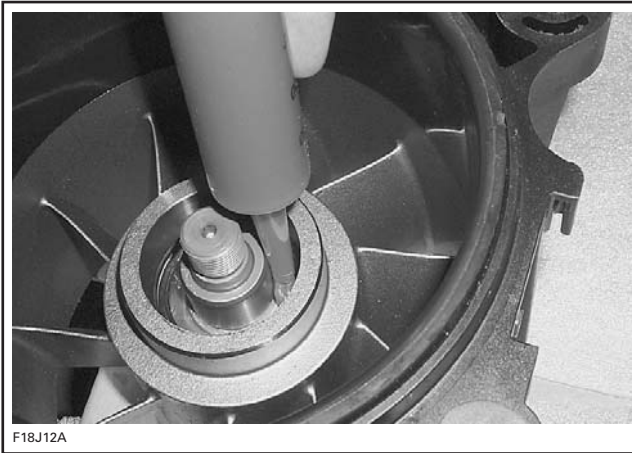

TYPICAL

7. Apply 11 g (.4 oz) of grease inside **NEW** double lip seal and in the seal lips.

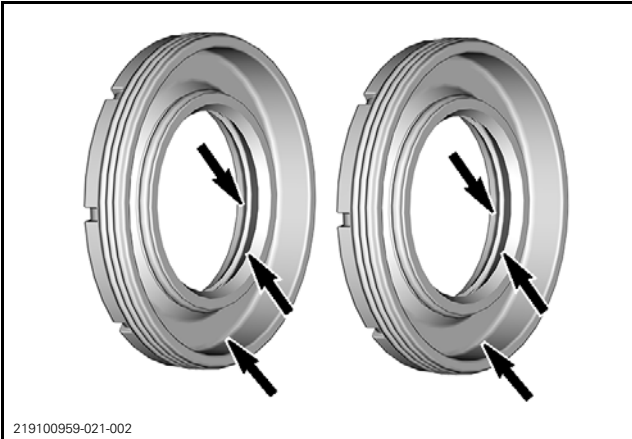

PUT GREASE IN ALL SEAL CAVITIES.

8. Install double lip seals making sure seal lip are facing upwards (toward impeller side).

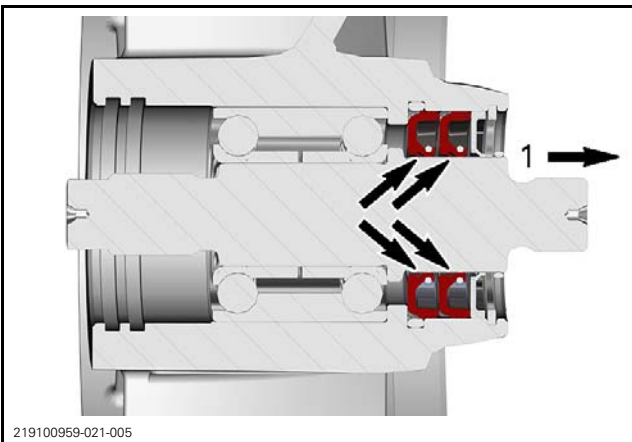

1. Toward impeller

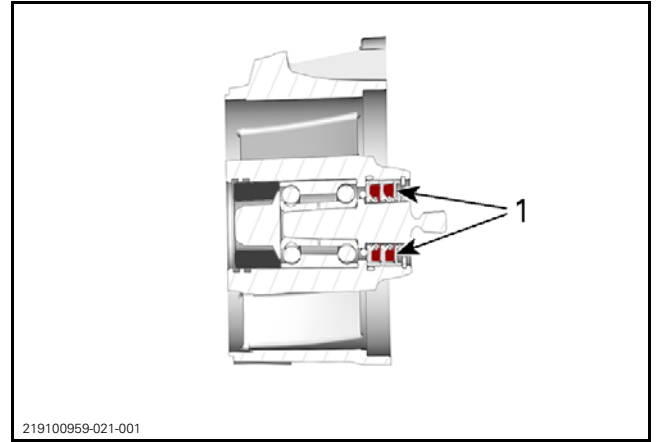

1. Grease in seals cavities

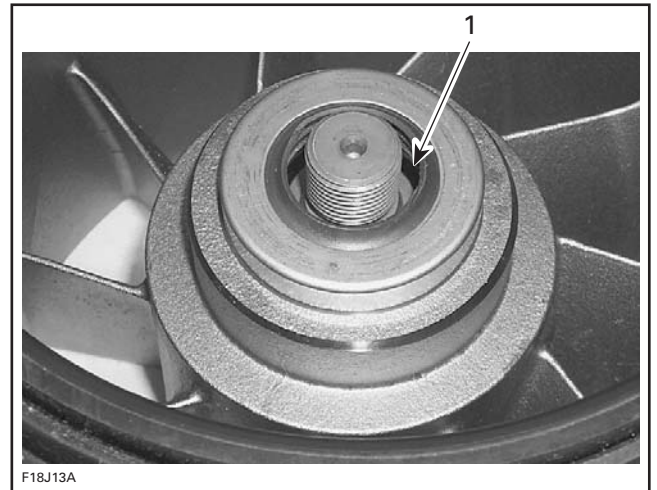

1. Seal lip facing up

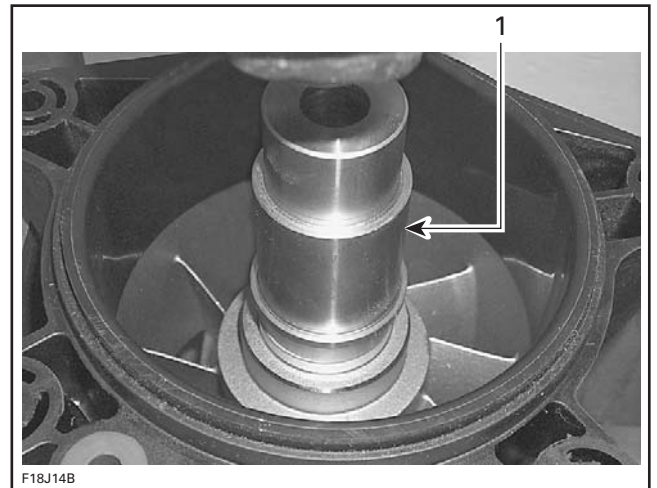

TYPICAL

1. Seal/bearing pusher

9. Install the other seal (thin). Ensure seal lip is facing up.

Subsection XX (JET PUMP)

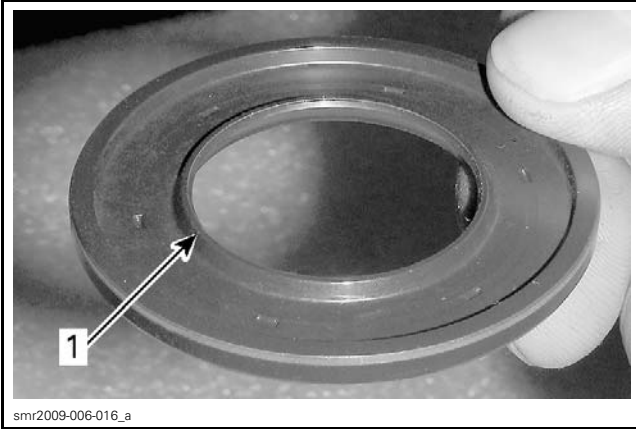

1. Seal lip facing up

10. Install circlip.

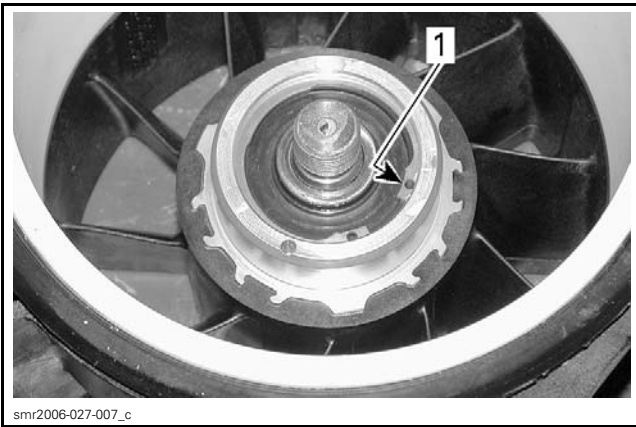

TYPICAL
1. Circlip

11. Turn pump upside down.

12. Before installing any other parts, pressurize jet pump to insure proper seal installation. Refer to *LEAK TEST* in this subsection.

13. Install impeller. Refer to *IMPELLER* in this subsection.

14. Mount in a vise the impeller remover/installer.

REQUIRED TOOL	
<p>IMPELLER REMOVER/INSTALLER (P/N 529 035 956)</p>	

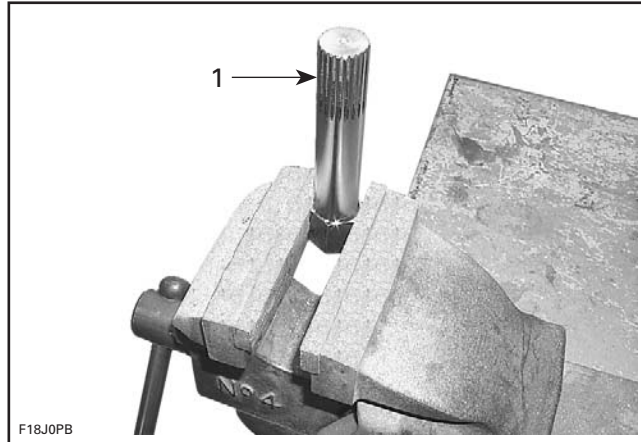

1. Impeller remover/installer tool

15. Install jet pump housing over tool.



TYPICAL

16. Using a 30 mm socket, screw the impeller shaft nut on clockwise.

17. Tighten nut as specified in exploded view.

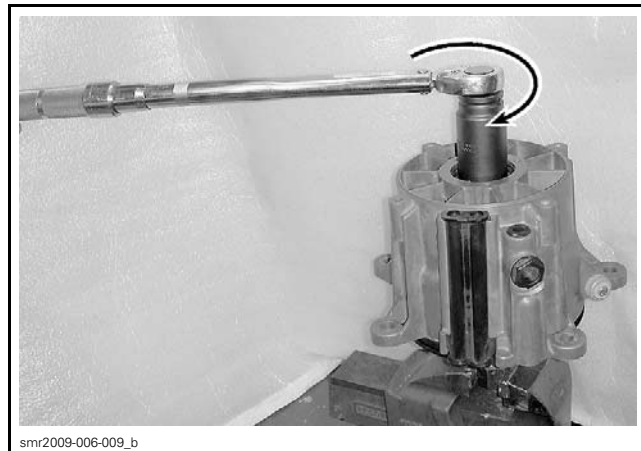

18. Apply 30 g (1.1 oz) of grease around nut.

SERVICE PRODUCTS

JET PUMP BEARING GREASE (P/N 293 550 032)

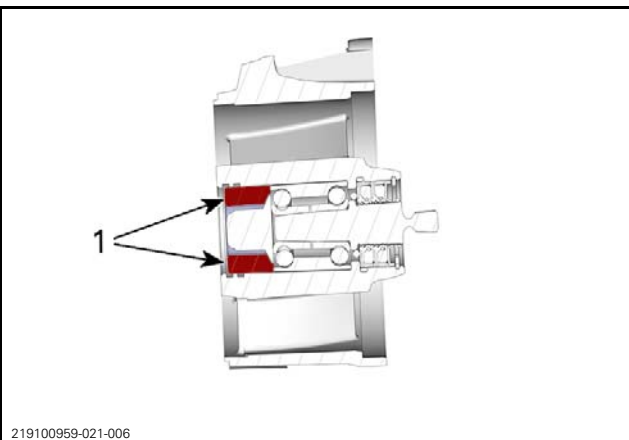
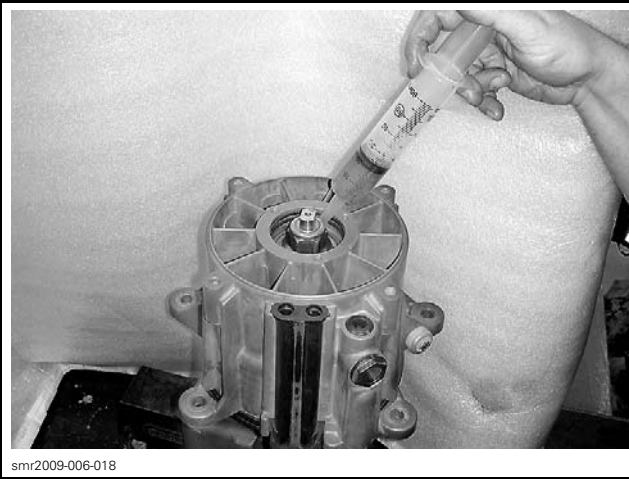

1. Grease around nut

19. Install the two O-rings in pump housing and make sure they are properly lubricated.

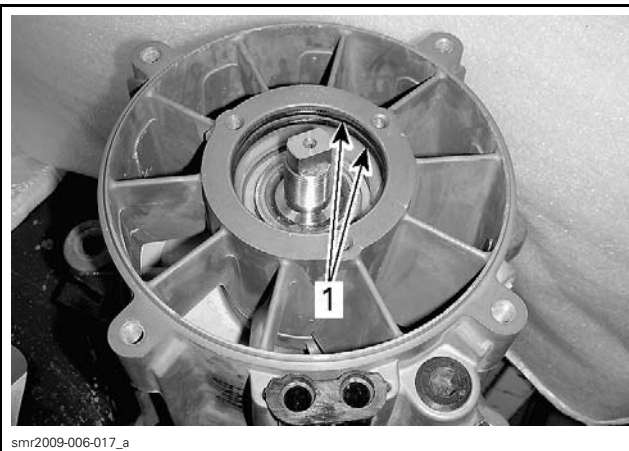

TYPICAL
1. O-rings

20. Install the impeller cover. Refer to *IMPELLER COVER* in this subsection.