

USER'S MANUAL

Operation Manual & Instruction

TYRE CHANGER

Contents

	1. Technical	
Data.....		1
	2.	
Structure.....		1
	3. Warning stickers and instruction of the machine.....	2
	4. Installation	
site		2
	5. Installation for the completely automatic machine.....	3
	6.	
Maintenance.....		3
	7. Instructions for the operation.....	4
	8.	
Inflating.....		5
	9.	
Transport.....		6
10. Electrical diagram.....		7
11. Instruction for the assemble of the vertical arm.....		10
12. Instruction for install the air regulator.....		13

1. Technical Data

2. Structure

Operation parts for completely automatic machine (Fig.1)

1. Pedal for tilting the mounting column
2. Pedal for rotating the clamping chuck
3. Pedal for pressing the tire
4. Tool box
5. Pedal for expanding the jaws
6. Tire crowbar
7. Clamping chuck
8. Jaw
9. Mount/demount head
10. Vertical shaft
11. Locking handle
12. Horizontal arm
13. Air inflator
14. Air regulator
15. Bead breaker shoe
16. Wheel support



(Fig.1)

- Padel configuration(From Left to Right)
- 1 & 7 Turntable Rotating
 - 2 & 3 Tower control
 - 4 & 5 Clamping Jaws in & out
 - 6 Bead breaker



3. Warning stickers and instruction of the machine



Never place leg between the bead breaker shoe and bead breaker rubber, avoid stepping the wrong pedal and cause injury of the operator.



Never place hand on the tire when the demount head is on the working position, avoid the injury of the operator.



Never place your hand between the tire and gripping device when operate the rim, avoid the injury of the operator.



The jaws should in closed position but not in open position when do the bead break, avoid the injury of the operator.



The operator should wear the protection glasses when inflate the tires with the machine with GT system, avoid something blow into eyes.



Never put hand between the rim and tire when inflate the tire, avoid the injury of the operator.



There should be nobody behind the tilting pole, when the machine is on the working position.

4. Installation site

When choose the place for installation be sure that it complies with current safety regulations.

The semi-automatic tire changer must be connected to the main electric power supply and air compressed system. It is therefore advisable to install the machine near these power sources.

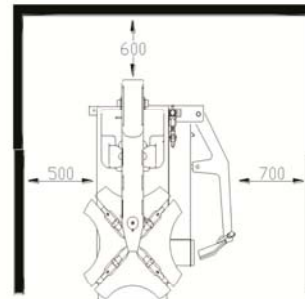

(Fig.2)

The place of installation must provide at least the space shown in figure 2, so as to allow all parts of the machine to be operated correctly and without any restriction.

If the machine is installed outside, it must be protected by a lean-to.

5. Installation for the completely automatic machine

Place the machine on the chosen place, and then fix it to the ground by fixing screw. Lift the tilting arm, and insert the PU hose (G) into the hole (Fig3). (Do not bend the hose) Then take out the part A (shown in Fig.3) from the accessory box, unscrew the cap on the top of part A, insert the part A into the hole that go through the main box of the machine and the bottom of the tilting arm, then tighten the bolt. Take out the part B (shown in Fig.3) from the accessory box, unscrew the spring on one side of part B, then insert part B into the hole that go through the part D, E, then screw the spring. Take out the side panel on the side of the machine. Connect the PU hose (G) that go through the main box of the machine with the part F.

After the above operation is finished, mount the part E on the arm (Fig.4), then mount parts D, C, B, A, G, F in sequence. During the operation, pay attention to the PU hose and other parts.

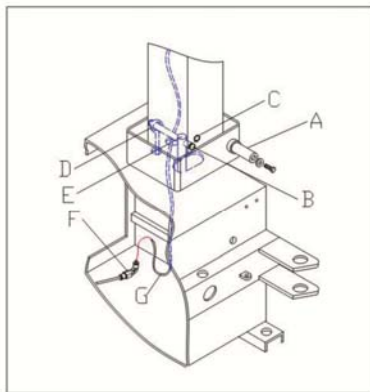

(Fig3)

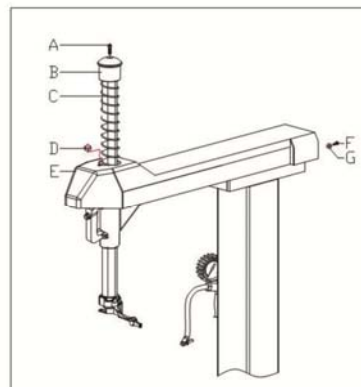

(Fig4)

6. Maintenance

The following maintenance must be done at least once every month.

- Check the oil level in the air-compressed cup periodically. If it needs to be filled, you must shut off air source, and then fill the SAE30 oil.
- Clean and lubricate all the moving parts of the turntable. (Fig.5)
- Check all connecting parts and bolts periodically and tighten them if necessary.

- Check and adjust the tension of the driving belt. (Fig.6)
- Keep the machine and the working area clean to avoid the dust entering the moving parts.
- Lubricate all the moving side of the machine weekly.
- Prepare a water segregator near the air-compressor, to reduce the amount of the water in the air that go through the machine.



(Fig5)

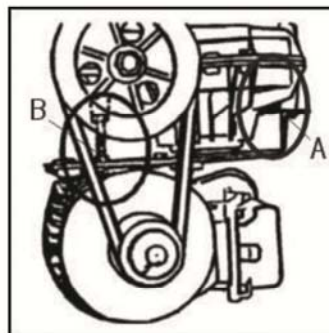

(Fig6)

7. Instructions for the operation

Demounting:

Do the operation as follow:

- Release all the air inside the tire.
- Remove the balance block from the external side of the rim.

(Fig.7)



(Fig.7)

- Place the tire between the bead breaker shoe and rubber pad, and make the shoe between the bead and the tire, step on the tire control pedal (Fig.1), to separate the bead from the rim. (Fig.8)

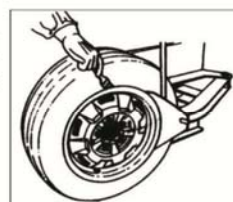

(Fig.8)

- Repeat above steps on the other parts of the tire to get the tire separated thoroughly from the rim.
- Set the vertical shaft in the working position, so that the mount/demount head is near the rim. The roller in the mount/demount head should be 2 mm from the rim to prevent scratching the rim. (Fig.9) Press the button on the locking handle to lock.

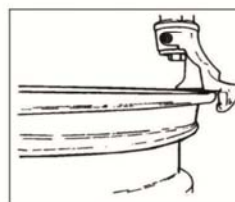

(Fig.9)

- Lift the bead onto the mount/demount head with the bead lifting tool, and step on the turntable control pedal 2(Fig.1) to turn the turntable clockwise till the bead is completely separated (Fig.10), it is suggested to place the mount/demount head about 10mm to the right side of the air valve if the wheel has a tube, so as not to damage the tube.

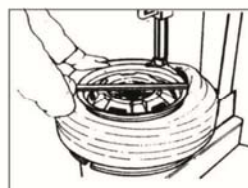

(Fig.10)

- Take out the tube if there is. Turn over the wheel to let the other side toward the mount/demount head, and repeat the above steps to demount the other side of the bead. (Fig.11)



(Fig.11)

Mounting:

- Clamp the rim on the turntable.
- Lubricate the bead with soap solution.
- Put the bead on the machine with the left side upward, and press down the tire simultaneously, and turn the turntable clockwise to let the bead enter the bead seat.
- Cover the tube onto the rim if there is, and repeat the above steps to mount the upper side of the tire.



(Fig.12)

8. Inflating

This machine is equipped with a gauge for pressure reading during inflation.

- Loose the tire from the turntable.

- Connect the inflator with the airvalve on the tire. (Fig.13)
- Press the gun inflator slowly for several times. Make sure the reading on the gauge does not exceed the manufacturer's limit.

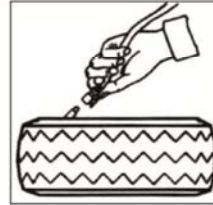

(Fig.13)

9. Transport

Make sure transport the machine with its original package, and place it according to the marks on the package. The packed machine should be moved by means of a fork lift truck of suitable capacity, insert the forks at the points shown in (Fig.14).

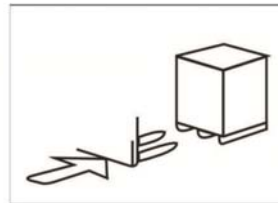

(Fig.14)

Helper Arm

1. Control panel
2. Tyre pressing block
3. Roller
4. Tyre lifter

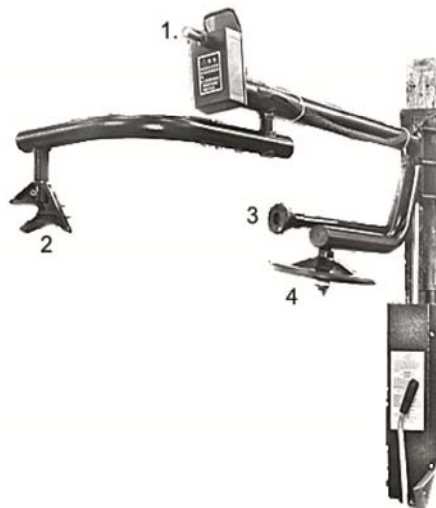

10. Electrical diagram

a. 220V-50hz/60hz 1P 1.1KW

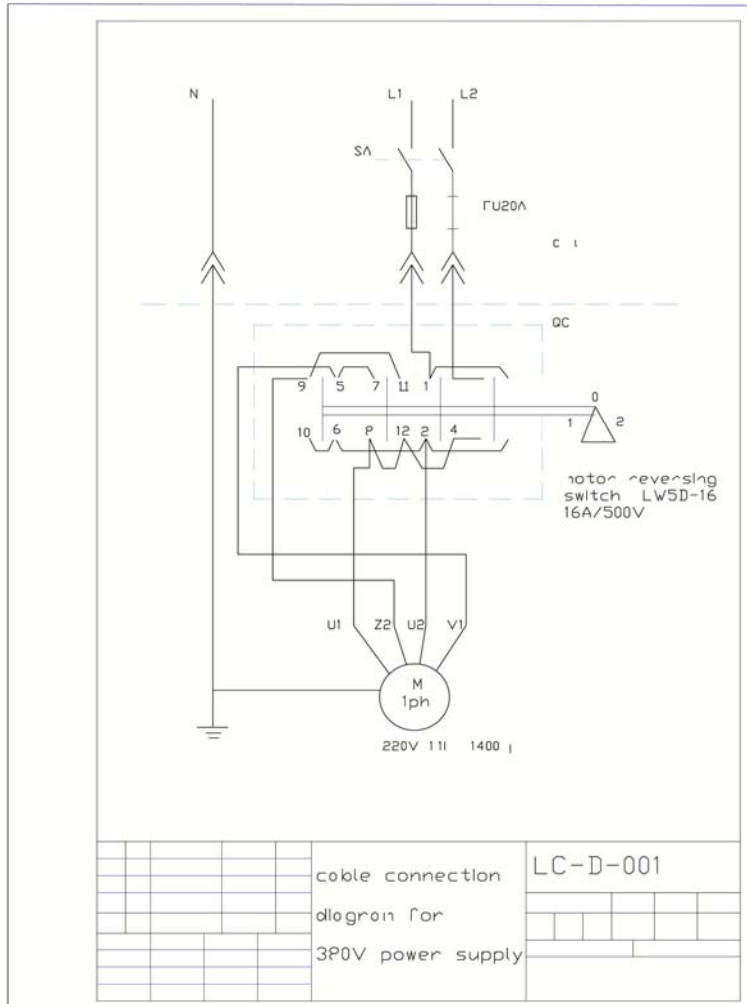

b. 380V-50hz/60hz 3P 0.75KW

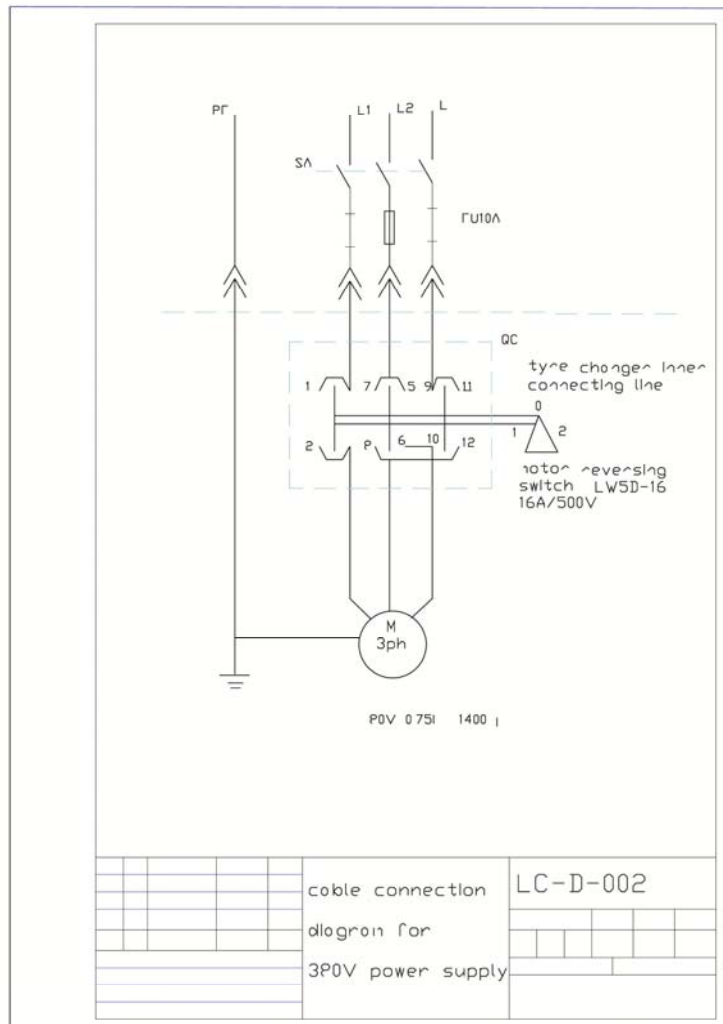

c. 110V/220V-50hz/60hz 1P 1.1KW

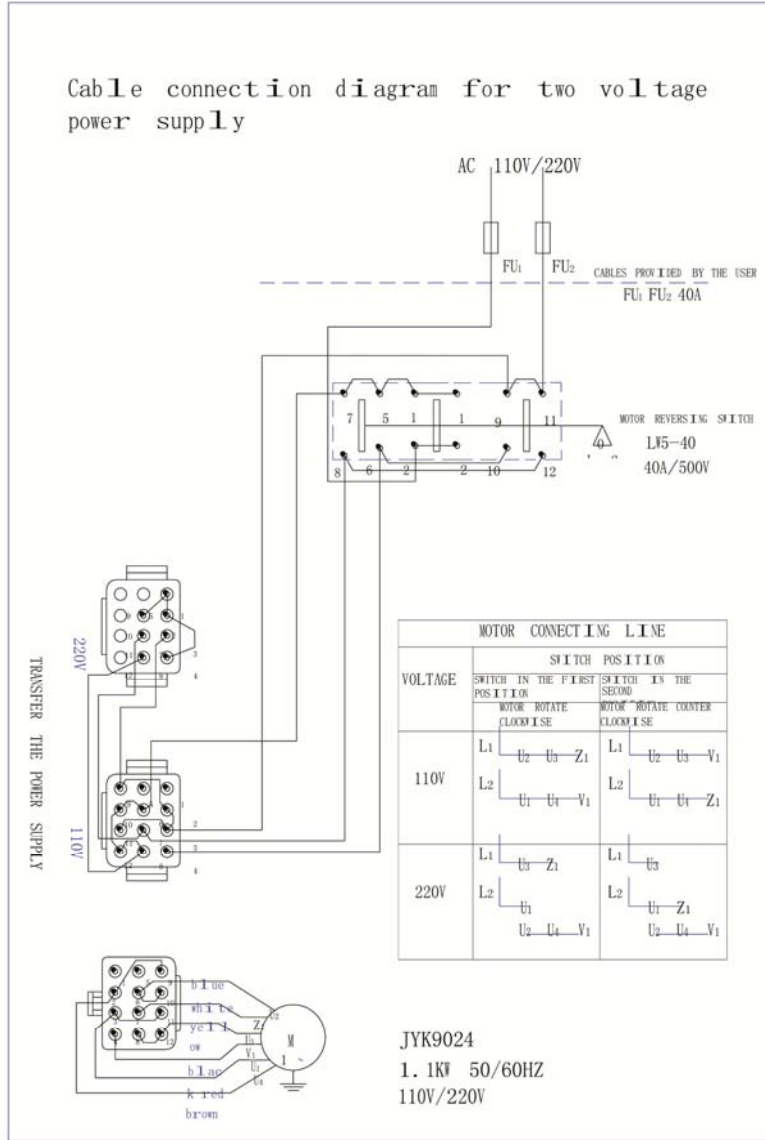

11. Instruction to assemble the vertical post

The 350GT(350) is disassemble packed before delivery, the vertical arm are disassembled before packed, the customer should assemble it according to the manual .

- Unpack the box; install the machine body in the working site, according to the manual.
- Open the accessory box, take out the spindle of (Fig.16-1, 2), and clean them.



(Fig.16)

- Unscrew the M6X16 (Fig.17), open the side panel, (Fig.17-2), unscrew the M6X16 on the tool box, (Fig.17-3), remove the tool box.



(Fig.17)

- Remove the vertical arm assy from the pallet, and then clean it. (Fig.18)



(Fig.18)

- Put the vertical arm on the bracket on the machine (Fig.19) body, the $\varnothing 6$ PV hose (Fig.19-1) should insert into the body through the hole A (Fig.19-2)

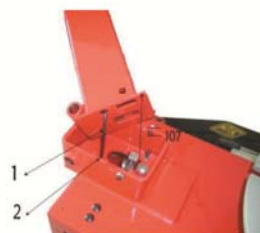

(Fig.19)



(Fig.20)

- a. Adjust the position of the vertical arm, make the hole of the spindle spacer (Fig.21-1) on the vertical arm match the holes of the spindle spacer on the bracket (Fig.21-2).

b. Remove the screw and washer on one side of the spindle (Fig.16-1), insert this spindle into the hole, (Fig.20), the end of the spindle should be 1mm (Fig.21) from the plane of the spindle spacer, put the spacer on the screw M16X25, then put the screw into the M16 hole, the torque should be 70N/M, both side should be with strength.



(Fig.21)

- Tilt back the vertical arm; cut the strap that fixing the connecting rod (Fig.22-1) and cylinder shaft (Fig.22-2).
- Unscrew the screw M12X50 (Fig.23-1) and locknut M12 (Fig.23-2), remove them.



(Fig.22)



(Fig.23)

- Position the hole of $\varnothing 6$ (Fig.24-1) match to the R15 holes (Fig.24-2), insert the spindle (with the seeger ring 16# removed on one end) (Fig.16-2) into the hole of $\varnothing 6$, through the hole of the connecting rod (Fig.22-1) and shaft (Fig.22-2) then insert to (Fig.24) the other hole of $\varnothing 6$, on the other side of the vertical arm, put the seeger ring by plier, make the vertical arm in the vertical position.



(Fig.24)

- Put on the screw M12X50 and nut, to fix the cylinder. (Fig.23-1)

- Connect the PV hose with the union (Fig.25) of the air hose.
- Mount the cover of the horizontal arm:
- ❖ Remove the nut (Fig.26-1) and the screw M6X12 (Fig.26-2)
- ❖ Remove the screw M10X30 (Fig.26-3) on the cap, take out the cap (Fig.26-4)(Note: the hexangular shaft should in the locking position, avoid it slide and damage the machine or the operator.



(Fig.25)



(Fig.26)



(Fig.27)

- ❖ Put the protection cover, mount the $\varnothing 5$ hole (Fig.27-1) to the top of hexangular shaft, the $\varnothing 2$ hole in front of the cover is mount to the M10X70 screw, then fix this screw by M10 nut. The back should be fixed by the screw M6X12 and flat washer, through the hole on the back of the horizontal arm and the hole M6.
- ❖ Mount the spring (Fig.27-4) cap (Fig.27-3) on the hexangular shaft, then fix it by the screw M10X30 (Fig.27-2)

- Adjust the positing screw on both side of the vertical arm, loose the nut, adjust by the screwdriver, make the head of the screw is 0.03 (Fig.28-1) from the vertical arm, the Lock the nut.(Fig.28)



(Fig.28)

- Mount the tool box: put the rubber washer on the three M6 holes, make the holes on the cover match the holes on the machine, tighten by M6X16 screw and flat washer (Fig.29-2).



(Fig.29)

- Testing by connect the air supply, press the vertical arm control pedal, the angle for tilt back is about 25°.The distance between the vertical arm bracket to the surface of the machine is 107mm.

Note: Lock the horizontal arm before tilt back the vertical arm to avoid the sliding of the horizontal arm make damage.

The speed of the vertical arm tilting back, can be control by the valve (Fig.23-3), release the nut of the adjustable screw, wrest the screw, the speed will be slow than before when wrest the screw by clockwise, and the speed will be faster than before when wrest the screw by counter-clockwise, then tighten the nut after the adjusting, the move time should two seconds, the screw have been adjusted before the delivery, if no special condition, it is not necessary to adjust it again.

Only the authorized person can do the adjustment, the manufacturer will have no responsibility for the improper operation.

- Fix the side panel by M6X16 screw, the operation is finished, for the others please reference to the manual.

12.Instruction for install the air regulator

In order to save the space and avoid the damage of the air regulator, put the air regulator into the accessory box before the delivery. When the customer received the machine, they should install it themselves; refer to the following instruction for install the air regulator:

- ◇ Preparation. Prepare one crosshead screwdriver, take out the air regulator and two screws M4 from the accessory box, check the air regulator, clean the surface (Fig.30)



(Fig.30)

- ◇ Fix the air regulator. Fix the air regulator with screws M4 on the machine, adjust the air regulator in one level, then tighten the two screws M4 (Fig.31)



(Fig.31)

- ✧ Connect the hose. Connect the main hose first, remove the union (which one can avoid the hose slide into the box) on the main hose ($\Phi 8PV$), then connect the main hose with the union of air regulator (Fig.3 Fig.4), then connect the hose on the gauge cover, with the seat in the air regulator, then tighten the union. (Fig.5 Fig.6)



(Fig.32)



(Fig.33)

- ✧ Check. Connect the air supply after the connecting of the hose, to check if there are leak or not, if there is no, the customer can use the machine (Fig.34).

Note: the go-out of the oil and the pressure has been adjusted before the delivery, so it is not necessary to adjust them.



(Fig.34)