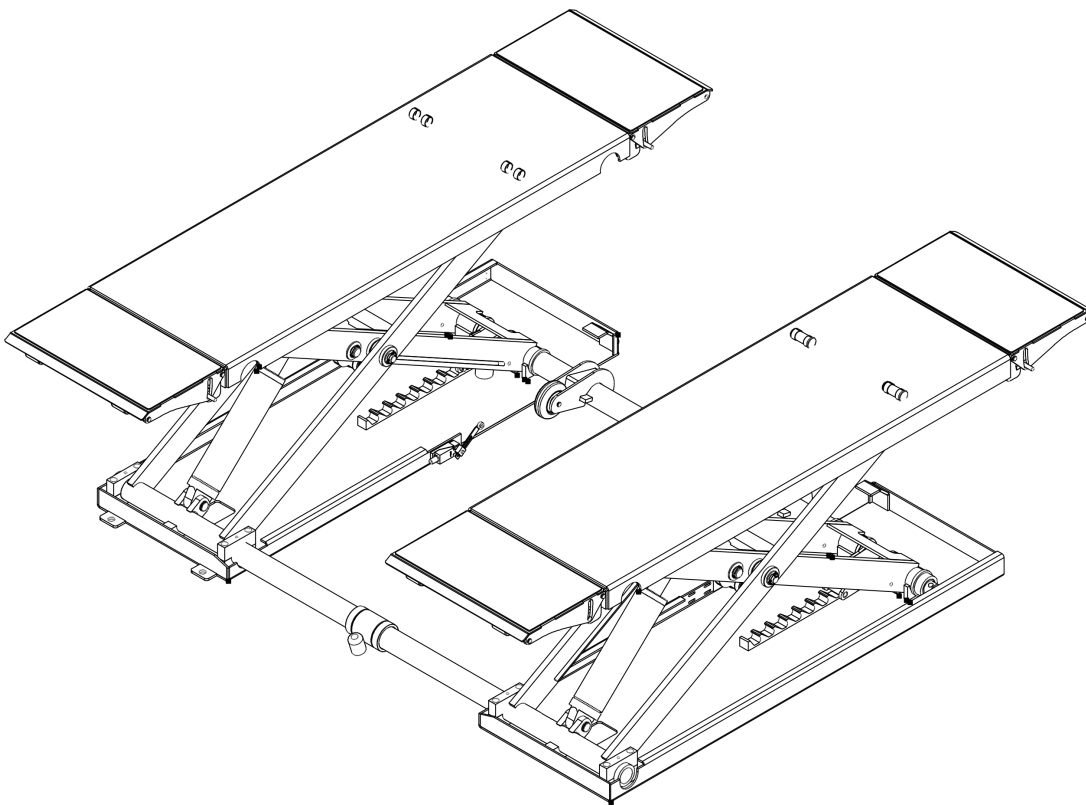


# MID-RISE SCISSOR LIFT

Installation/Operation & Maintenance Manual



**MODEL: HXL6230**

*Please read through this manual before operation. You must read and understand the precautions for safety to protect your safety and any damage to your property.*



## NOTE TO THE USER

Thank you for purchasing our products.  
Please read this instruction carefully for safe and proper use of the car lift, and keep it handy for future reference.

- This Manual is for model: HXL6230
- As for the assurance of safety in design and construction of car lift, read this Manual first.
- Please make sure that this manual is delivered to end users for their implementation of safety.
- Don't use the car lift in a potentially explosive atmosphere.

ANY PART OF THIS PRINT MUST NOT BE REPRODUCED  
IN ANY FORM WITHOUT PERMISSION.  
THIS PRINT IS SUBJECT TO CHANGE WITHOUT NOTICE.



# TABLE OF CONTENTS

Chapter 1 Features-----	1
Chapter 2 Safety -----	1
2.1 Introduction-----	1
2.2 Safety Instructions for Commissioning -----	1
2.3 Safety Instructions for Operation-----	1
2.4 Safety Instructions for Servicing-----	2
2.5 Risks for People-----	2
Chapter 3 Packing, Transportation and Storage -----	3
3.1 Packing-----	3
3.2 Lifting and Handling-----	3
3.3 Storage and Stacking of Packages-----	3
3.4 Delivery and Check of Packages-----	4
Chapter 4 Technical data-----	4
4.1 Parameters-----	4
4.2 Layout-----	4
Chapter 5 Installation and Debug-----	5
Chapter 6 Operation-----	6
Chapter 7 Moving the lift -----	7
Chapter 8 Maintenance-----	8
Chapter 9 Trouble Shooting-----	9
APPENDIX A SPECIAL NOTES -----	10
APPENDIX B SPARE PARTS -----	10
APPENDIX C CIRCUIT DIAGRAM -----	16
APPENDIX D PNEUMATIC SCHEMATIC DIAGRAM -----	18
APPENDIX E HYDRAULIC PRESSURE SCHEMATIC DIAGRAM-----	19

# TABLE OF CONTENTS

## Chapter 1 Features

1. With A3 steel plate, the strength of the lift is enhanced, avoid deformation, guarantee the service life.
2. Hydraulic system adopts differential cylinder, which one is a kind of high quality high-pressure cylinder. With a Max pressure 22Mpa, the hydraulic pump is a kind of super-high pressure pump from Italy. Hydraulic valve adopts Italy thread cartridge inserted valve, guarantee the working pressure of hydraulic system and its long-term balanced usage.
3. Hydraulic and mechanical double safety lock, guarantee an absolute safety service.

### Description of Middle Rise Lift

Middle rise lift is specially designed for the tyre-changing of car. With its elaborate design, reasonable structure and easily-operation, it is very popular with the customers. When using this machine, the bottom frame could be placed on the ground or embedded bellow the ground . These two bottom frames must be on the same horizon plain, fix this machine with anchor bolts.

## Chapter 2 Safety

### 2.1 Introduction

Thoroughly read this manual before operating the lift and comply with the instructions. Always display the manual in a conspicuous location.

Personal injury and property damage incurred due to non-compliance with these safety instructions are not covered by the product liability regulations.

### 2.2 Safety Instructions for Commissioning

The lift may be installed and commissioned by authorized service personnel only.

The standard lift version may not be installed and commissioned in the vicinity of explosives or flammable liquids, outdoors or in moist rooms (e.g. car wash).

### 2.3 Safety Instructions for Operation

- *Read the operating manual.*
- *Lift operation by authorized personnel over 18 years only.*
- *Always keep the lift and lift area clean and free of tools, parts, debris etc.*
- *After raising the vehicle briefly, stop and check the disk adapters for secure contact.*
- *Make sure the vehicle doors are closed during raising and lowering cycles.*
- *Closely watch the vehicle and the lift during raising and lowering cycles.*
- *Do not allow anyone to stay in lift area during raising and lowering cycles.*
- *Do not allow anyone on lift or inside raised vehicle.*
- *Only use the lift for its intended purpose.*

- *Comply with the applicable accident prevention regulations.*
- *Do not overload the lift. The rated load capacity is indicated on the lift nameplate.*
- *Only use the vehicle manufacturer's recommended lift points.*
- *After positioning the vehicle apply the parking brake.*
- *Use caution when removing or installing heavy components (center-of-gravity displacement).*
- *The main switch serves as emergency switch. In case of emergency turn to position 0.*
- *Protect all parts of the electrical equipment from humidity and moisture.*
- *Protect the lift against unauthorized usage by padlocking the main switch.*

## 2.4 Safety Instructions for Servicing

- *Maintenance or repair work by authorized service personnel only.*
- *Turn off and padlock the main switch before doing any maintenance, or repair work.*
- *Work on pulse generators or proximity switches by authorized service personnel only.*
- *Work on the electrical equipment by certified electricians only.*
- *Ensure that ecologically harmful substances are disposed of only in accordance with the appropriate regulations.*
- *Do not use high pressure / steam jet cleaners or caustic cleaning agents. Risk of damage!*
- *Do not replace or override the safety devices.*

## 2.5 Risks for People

All risks the personnel could run, due to an improper use of the lift, are described in this section.

### PERSONNEL CRUSHING RISKS

During lowering of runways and vehicles, personnel must not be within the area covered by the lowering trajectory. The operator must be sure no one is in danger before operating the lift.



Fig. 1

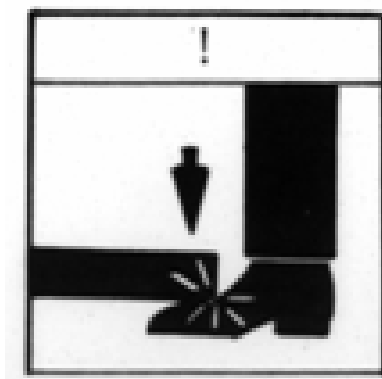


Fig. 2

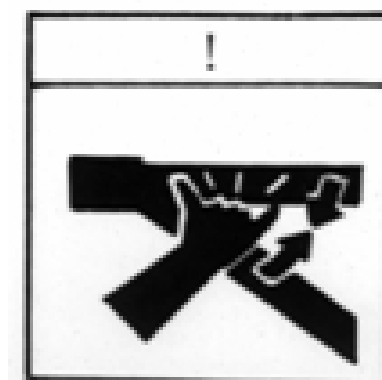
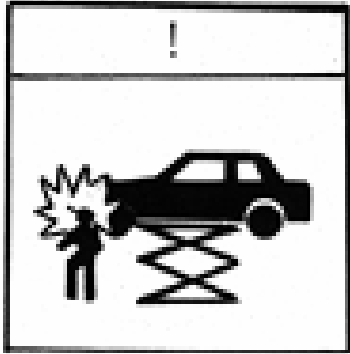


Fig. 3



## **BUMPING RISK**

When the lift is stopped at relatively low height for working, the risk of bumping against projecting parts occurs.



*Fig. 4*

## **RISK OF THE VEHICLE FALLING FROM THE LIFT**

Vehicle falling from the lift can be caused when the vehicle is improperly placed on platforms, and when its dimensions are incompatible with the lift or by excessive movement of the vehicle.

In this case, keep immediately away from the working area.

## **Chapter 3 Packing, Transportation and Storage**

Only skilled personnel who are familiar with the lift and this manual shall be allowed to carry out packing, lifting, handling, transport and unpacking operations.

### **3.1 Packing**

The packing of the lift is delivered in following components:

N. 2 base units packed in a steel frame, wrapped up in non-scratch waterproof material and sealed with 2 straps

N. 1 power unit packed in a plywood box

N. 4 drive-on ramps wrapped up in non-scratch waterproof material, including

N. 4 rubber pad, N. 4 hydraulic hoses and N. 8 anchor bolts.

(If requested, optional accessories are available to satisfy each customer's requirements). The average weight of the package is 800 kg.

### **3.2 Lifting and Handling**

When loading/unloading or transporting the equipment to the site, be sure to use suitable loading (e.g. cranes, trucks) and hoisting means. Be sure also to hoist and transport the components securely so that they cannot drop, taking into consideration the package's size, weight and centre of gravity and its fragile parts.

**Warning: Hoist and handle only one package at a time**

### **3.3 Storage and Stacking of Packages**

Packages must be stored in a covered place, out of direct sunlight and in low humidity, at a temperature between -10°C and +40°C. Stacking is not recommended: the package's narrow base, as

well as its considerable weight and size make it difficult and hazardous.

### 3.4 Delivery and Check of Packages

When the lift is delivered, check for possible damages due to transport and storage; verify that what is specified in the manufacturer's confirmation of order is included. In case of damage in transit, the customer must immediately inform the carrier of the problem.

Packages must be opened paying attention not to cause damage to people (keep a safe distance when opening straps) and parts of the lift (be careful the objects do not drop from the package when opening).

## Chapter 4 Technical data

### 4.1 Parameters

Lifting Capacity	3,500kg
Max. Lifting Height	1050mm
Platform Length	1430mm
Platform Width	500mm
Rated Voltage	380V/50Hz/3Ph
Hydraulic Oil	46# anti-grinding oil
Compressed Air Pressure	0.6~0.8MPa
Oil Pressure	25MPa
Rise Time	45~50 Sec.
Lowering Time	35~40 Sec.
Dimension	1920x1780x110mm
Rated Power	460kg
Noise	≤70dB
Working Temperature	-10℃ ~-40℃
Installed Position	Indoor

Table 1

### 4.2 Layout

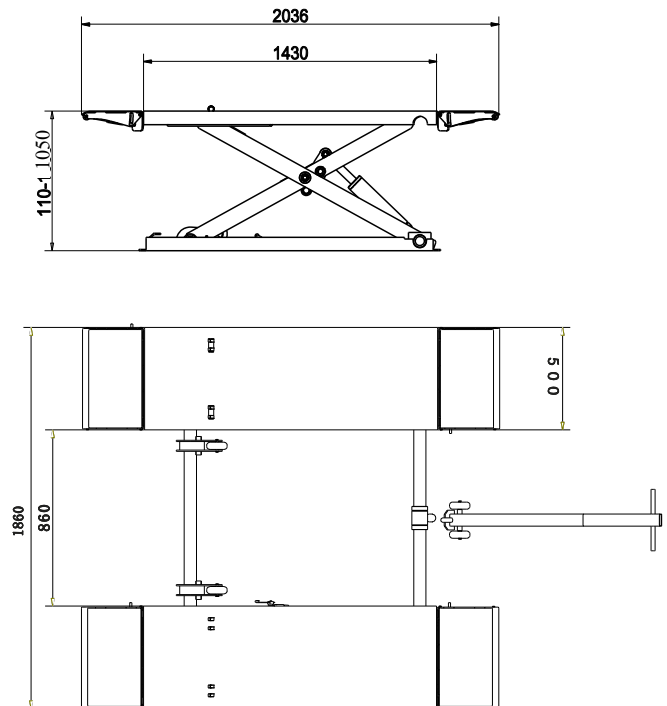
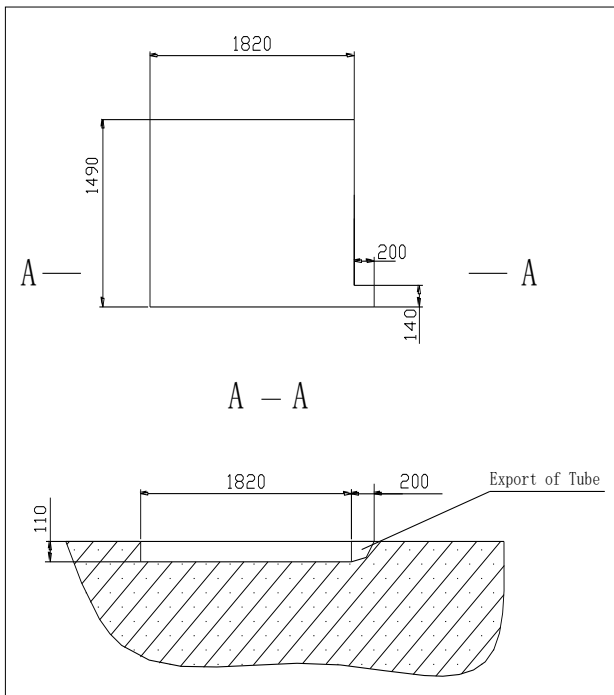


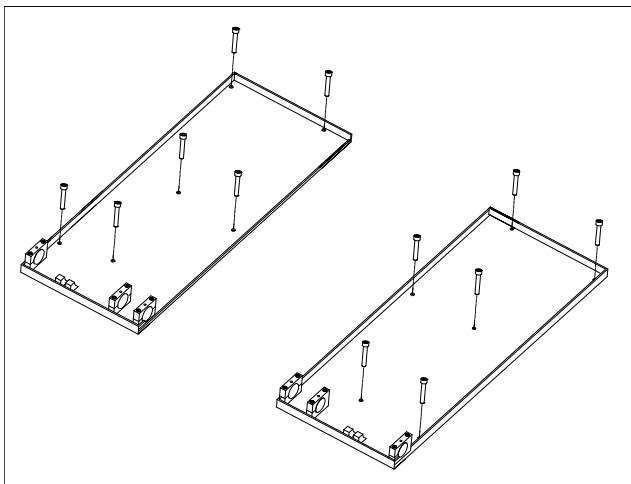
Fig. 5

## Chapter 5 Installation and Debug

1. Lay the foundations according to the foundations drawing:

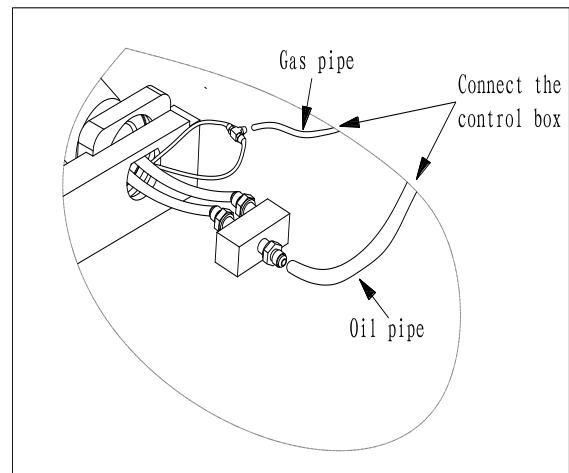


**Fig. 6**



**Fig. 7**

2. Connect the power incoming line, air source intake air inlet pipe, oil pump high press pipe. The control box should be placed at a safety place and connect the earth wire.



**Fig. 8**

3. Fill up the oil tank with 12L hydraulic oil
4. Connect the oil pipe according to the oil connection. Connect the air pipe.
5. Connect the power line and push rise switch, the motor should make a clockwise rotation.
6. Lock the machine at the same safety gear, flat the ground and fix the foundation bolt.
7. Check the electro-circuit, oil circuit, air circuit carefully. Put it into practice.

## Chapter 6 Operation

### **Safety instructions for operation:**

- Always keep lift and lift area free of tools, parts, debris etc. The car on the platform should be flat, stable.
- Do not allow anyone to stay in lift area or stand on the platform during raising and lowering cycles.
- Do not overload the lift.
- Handle up the manual brake of the car and stack up antiskid pad when the car is on the lift.
- The rise and fall should be synchronous avoiding any abnormal condition.
- When this machine is locked, these two platform should be on the same plane.
- When the operation is finished, the platform should be lowered at a bottom position.

**First: Read Electric Appliance Operation Carefully.**

#### **1. UP:**

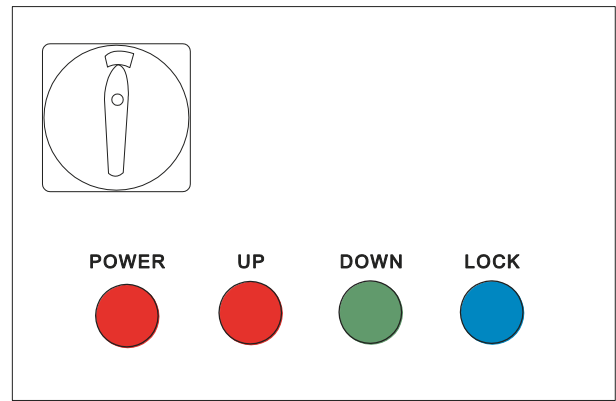
Press the “UP” button, the platform rises. Release this button, it stops.

#### **2. Lock:**

When the platform rises at a height, release the “UP” button and press “LOCK” button, this platform begin falling. When the safety gear block the safety claw, it is locked.

#### **3. DOWN:**

Turn right ‘DOWN’ knob, buzzer rings for two seconds and the platforms begins to descend.



**Fig. 9**

## Chapter 7 Moving the lift

Push the stand and put the small weldment part through the hole on frame structure, lever the lift and drag the lift to another place.



Fig. 10

**Warning:** During moving the machine, check the three wheels and the pull pole are equipped well. If the lift raising to some height, forbid moving the lift again with the pole.



Fig. 11



Fig. 12

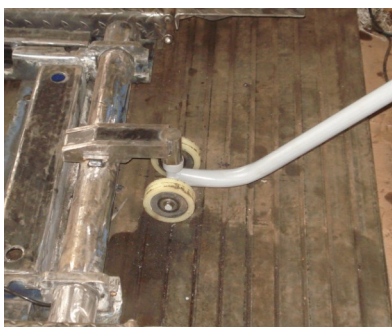


Fig. 13

## Chapter 8 Maintenance

1. Keep all the moveable parts clean, regularly grease them.
2. All the oil cups should be refilled once every week.
3. Replace the hydraulic oil once every year. Clean the oil tank and oil filter. The oil level should keep upper limit.

4. The compressed air for the pneumatic safety lock should be filtered to ensure the reliability of the safety lock.

### 5. Ordinary Maintenance

The lift has to be properly cleaned at least once a month using self-cleaning clothes, Lubricate all pivot pins at least once a week.

Every 3 months	Hydraulic circuit	<ul style="list-style-type: none"> <li>■ Check oil tank level; Refill with oil if needed.</li> <li>■ Check the circuit for oil leakage.</li> <li>■ Check seals for proper conditions and replace the, if necessary.</li> </ul>
	Foundation bolts	<ul style="list-style-type: none"> <li>■ Check bolts for proper tightening.</li> </ul>
	Hydraulic pump	<ul style="list-style-type: none"> <li>■ Verify that no noise changes take place in the pump when running and check fixing bolts for proper tightening.</li> </ul>
	Safety system	<ul style="list-style-type: none"> <li>■ Check safety devices for proper operation.</li> </ul>
Every 6 months	Oil	<ul style="list-style-type: none"> <li>■ Check oil for contamination or ageing. Contaminated oil is the main reason for failure of valves and shorter life of gear pumps.</li> </ul>
Every 12 months	General check	<ul style="list-style-type: none"> <li>■ Verify that all components and mechanisms are not damaged.</li> </ul>
	Electrical system	<ul style="list-style-type: none"> <li>■ A check of the electrical system to verify that motor, limit switch and control panel operate properly must be carried out by skilled electricians.</li> </ul>
	Oil	<ul style="list-style-type: none"> <li>■ Empty the oil tank and change the hydraulic oil.</li> </ul>

**Table 2**

## Chapter 9 Trouble Shooting

TROUBLE	CAUSE	REMEDY
Motor does not run	<ol style="list-style-type: none"> <li>1. Button does not work</li> <li>2. Wiring connections are not in good condition or disconnection</li> <li>3. AC contactor burned out</li> <li>4. Motor burned out</li> </ol>	<ol style="list-style-type: none"> <li>1. Replace button</li> <li>2. Repair all wiring connection</li> <li>3. Replace AC contactor</li> <li>4. Repair or replace motor</li> </ol>
Motor runs but the lift is not raised	<ol style="list-style-type: none"> <li>1. Motor runs in reverse rotation</li> <li>2. Low oil level</li> <li>3. The Gear Pump out of operation</li> <li>4. Relief valve or check valve in damage</li> <li>5. Shaft Coupling in damage</li> </ol>	<ol style="list-style-type: none"> <li>1. Reverse two power wire</li> <li>2. Fill tank</li> <li>3. Repair or replace</li> <li>4. Repair or replace</li> <li>5. Replace Shaft Coupling</li> </ol>
Lift raised slowly	<ol style="list-style-type: none"> <li>1. Oil line is jammed</li> <li>2. Gear Pump leaks</li> <li>3. Overload lifting</li> <li>4. Power Voltage low</li> <li>5. Oil mixed with air</li> </ol>	<ol style="list-style-type: none"> <li>1. Clean the oil line</li> <li>2. Replace Pump</li> <li>3. Check load</li> <li>4. Check electrical system</li> <li>5. Fill tank and bleeding air</li> </ol>
Lift can not lower	Hydraulic Solenoid valve out of operation	Check Solenoid valve and Air line

**Table 2**

## APPENDIX A SPECIAL NOTES

### A.1 DISPOSAL OF USED OIL

Used oil, which is removed from the power unit and the plant during an oil change, must be treated as a polluting product, in accordance with the legal prescriptions of the country in which the lift is installed.

### A.2 MACHINE DEMOLITION

***DURING MACHINE DEMOLITION, COMPLY WITH ALL THE SAFETY PRECAUTIONS DESCRIBED IN CHAPTER 2, WHICH ARE ALSO VALID FOR ASSEMBLING.***

The machine must be demolished by authorized technicians, just like for assembling. The metallic parts can be scrapped as iron. In any case, all the materials deriving from the demolition must be disposed of in accordance with the current standards of the country in which the rack is installed. Finally, it should be recalled that for tax purposes, demolition must be documented; submitting claims and documents according to the current laws in the country in which the rack is installed at the time the machine is demolished.

## APPENDIX B SPARE PARTS

### B.1 SPARE PARTS

When replacing parts and making repairs, comply with ALL THE SAFETY PRECAUTIONS described in **Chapter 8 MAINTENANCE** and in **Chapter 2 SAFETY**.

Take all the necessary precautions to **AVOID ACCIDENTAL START-UP OF THE LIFT**.

- ◆ The switch on the control box must be blocked in position 0 with a lock
- ◆ The key of the lock must be kept by the maintenance fitter during the maintenance operation.

### B.2 PROCEDURE FOR ORDERING SPARE PARTS

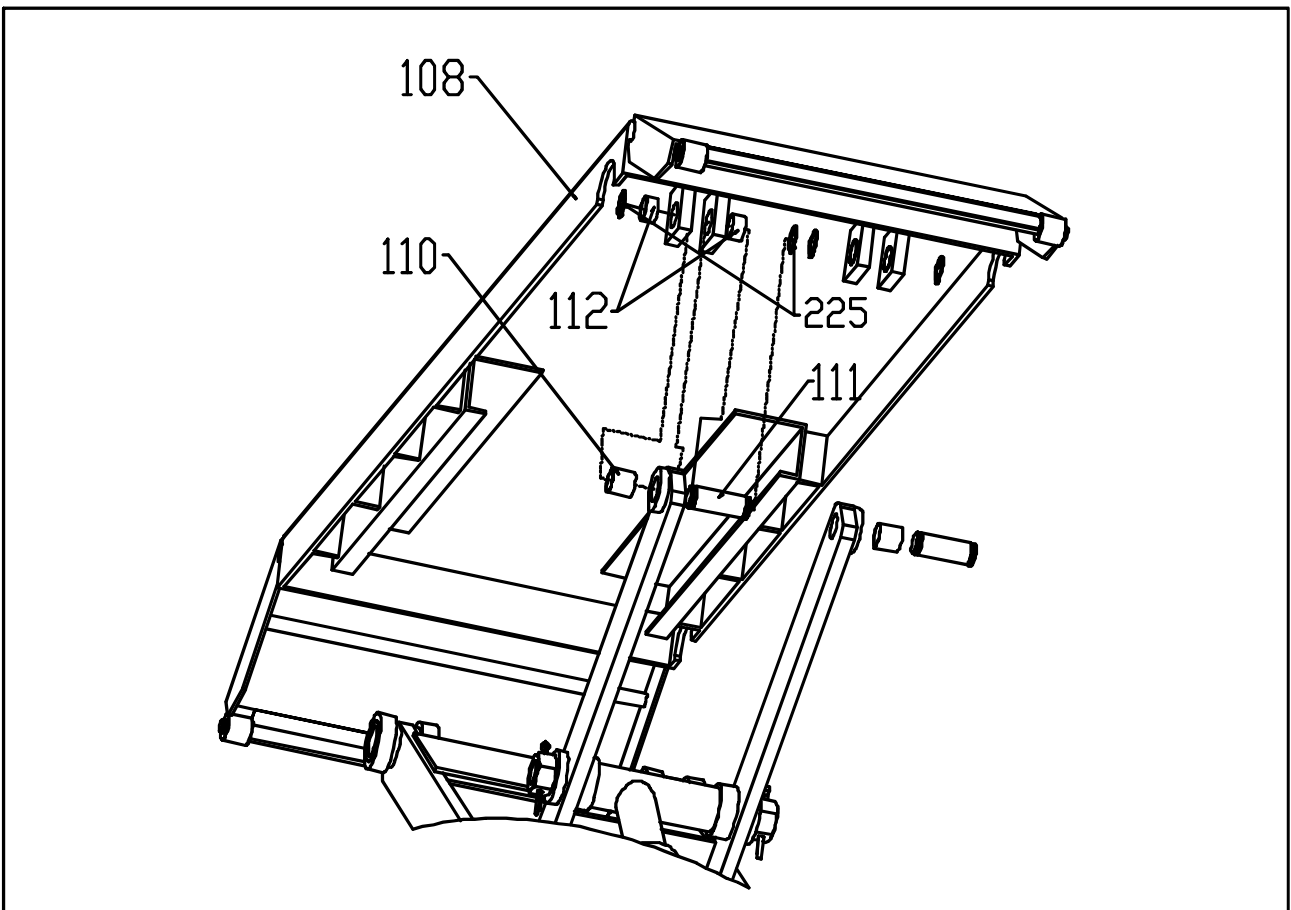
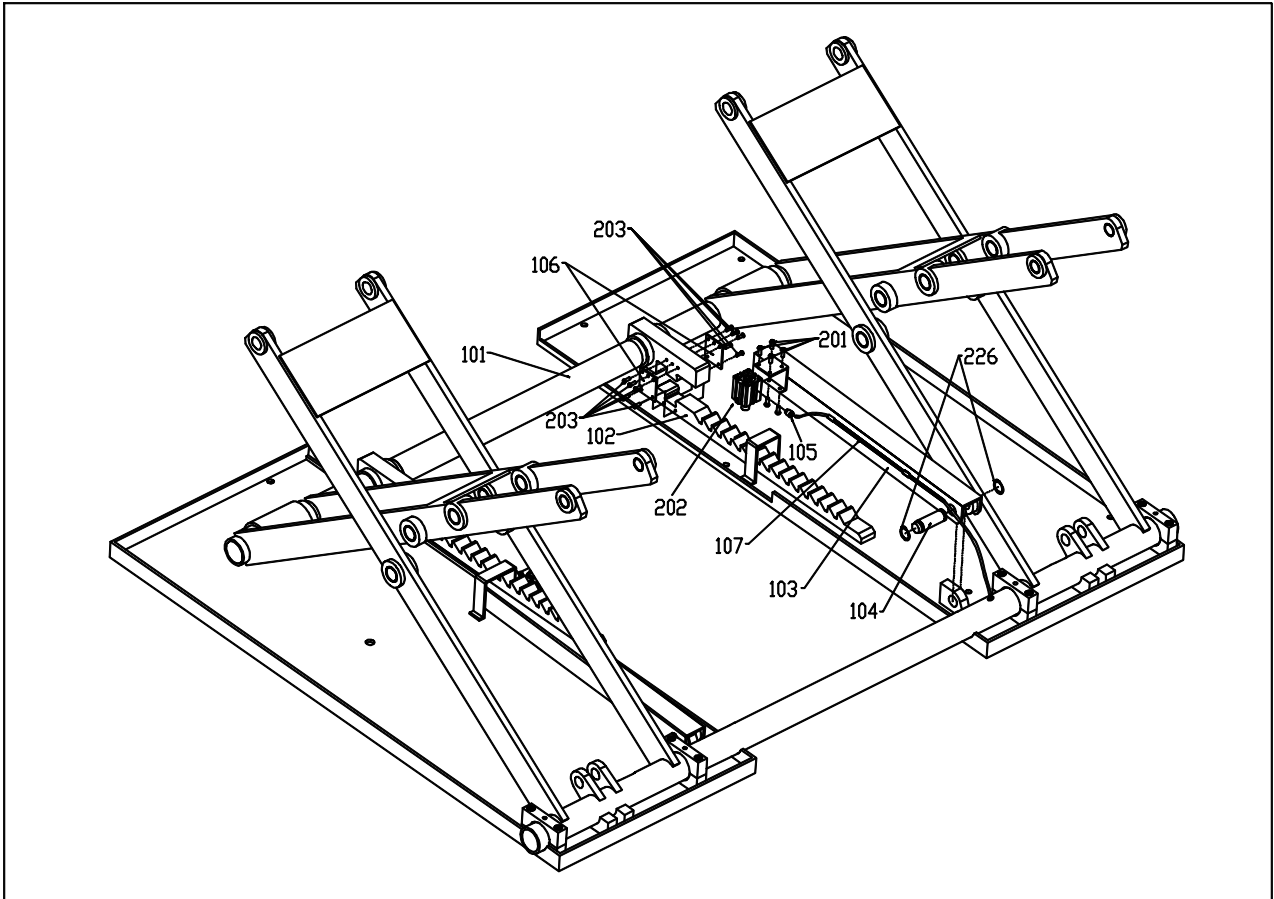
To order spare parts:

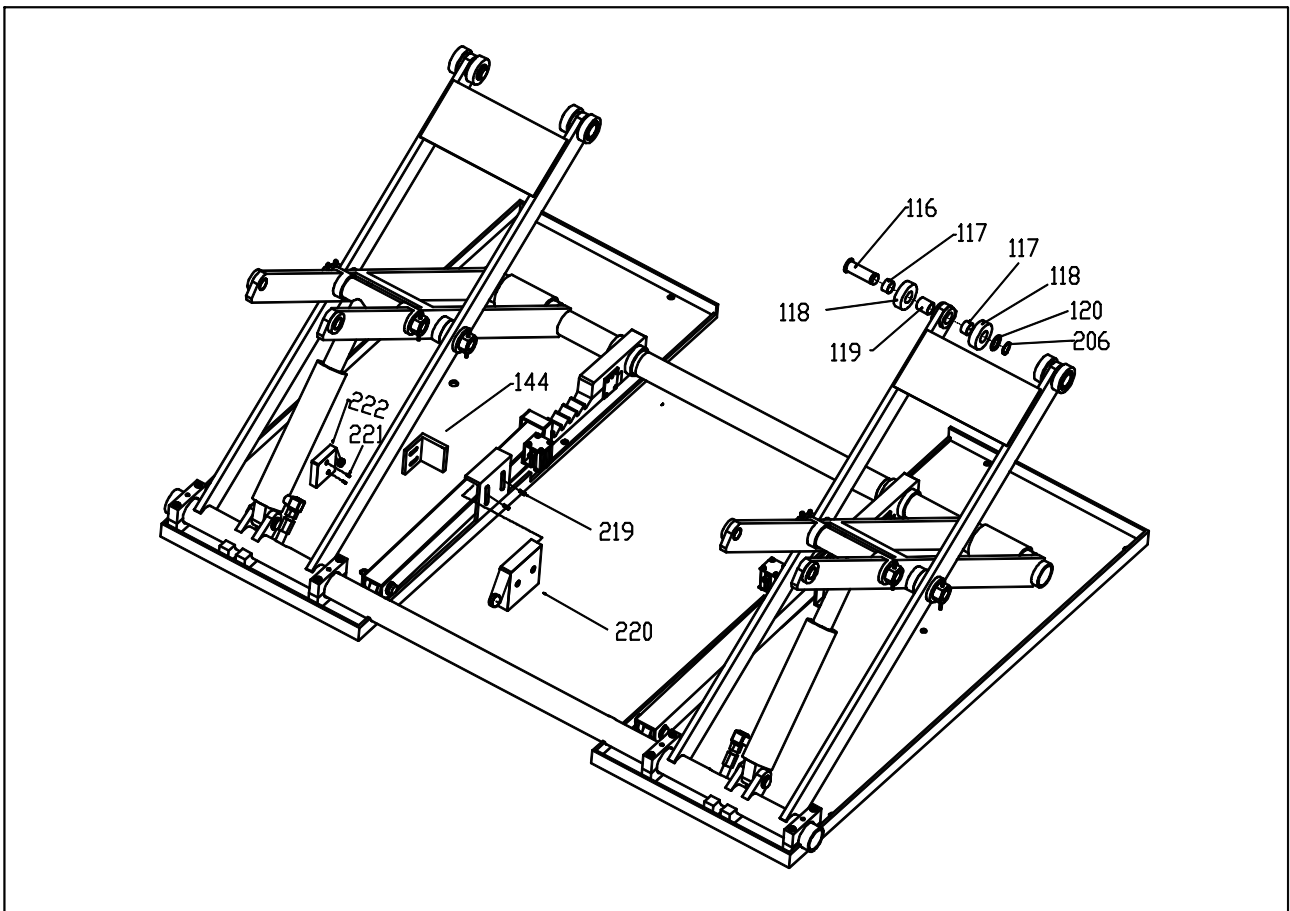
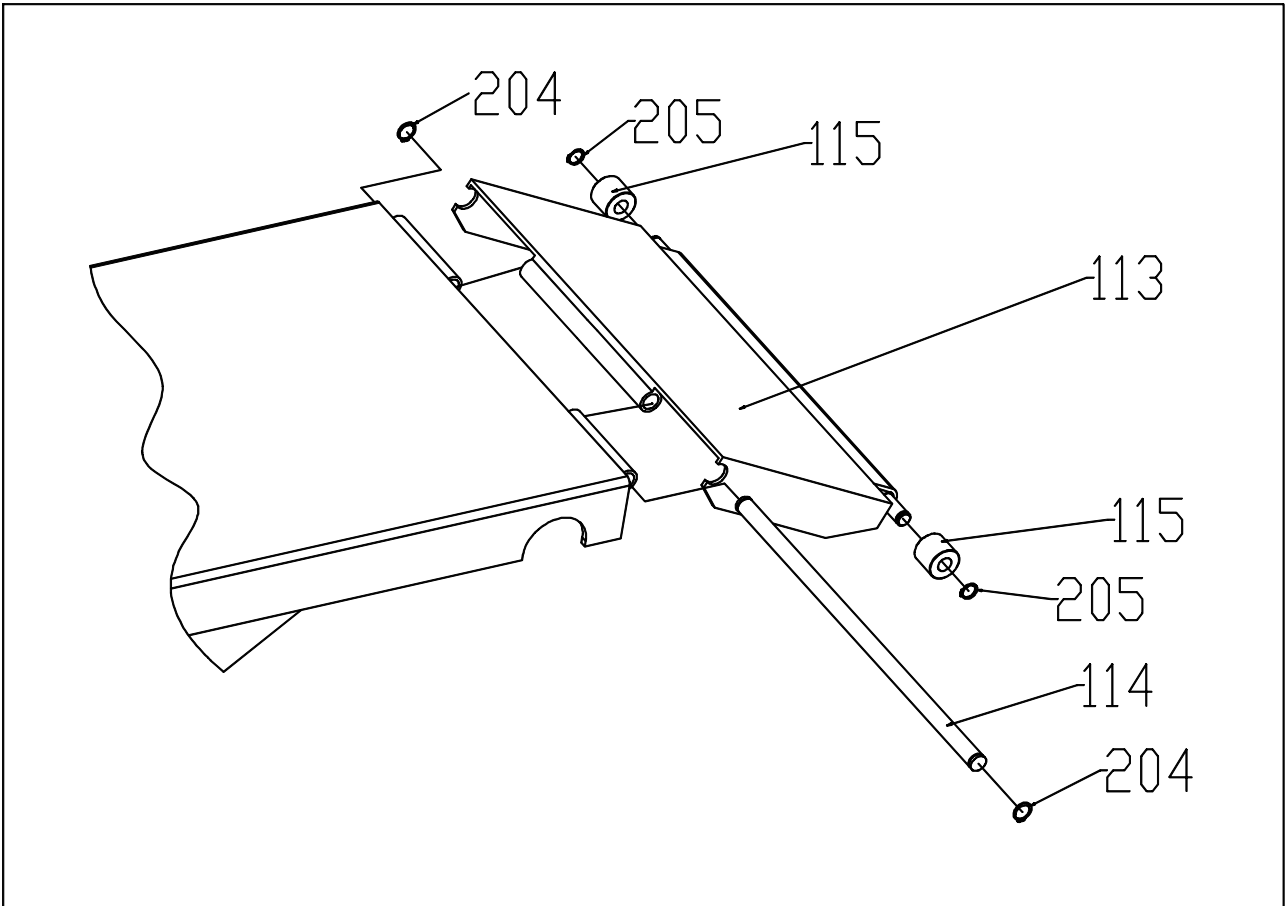
- ◆ Indicate the serial number of the lift and the year built
- ◆ Indicate the code of the piece requested (see the "CODE" columns in the tables)
- ◆ Indicate the quantity required.

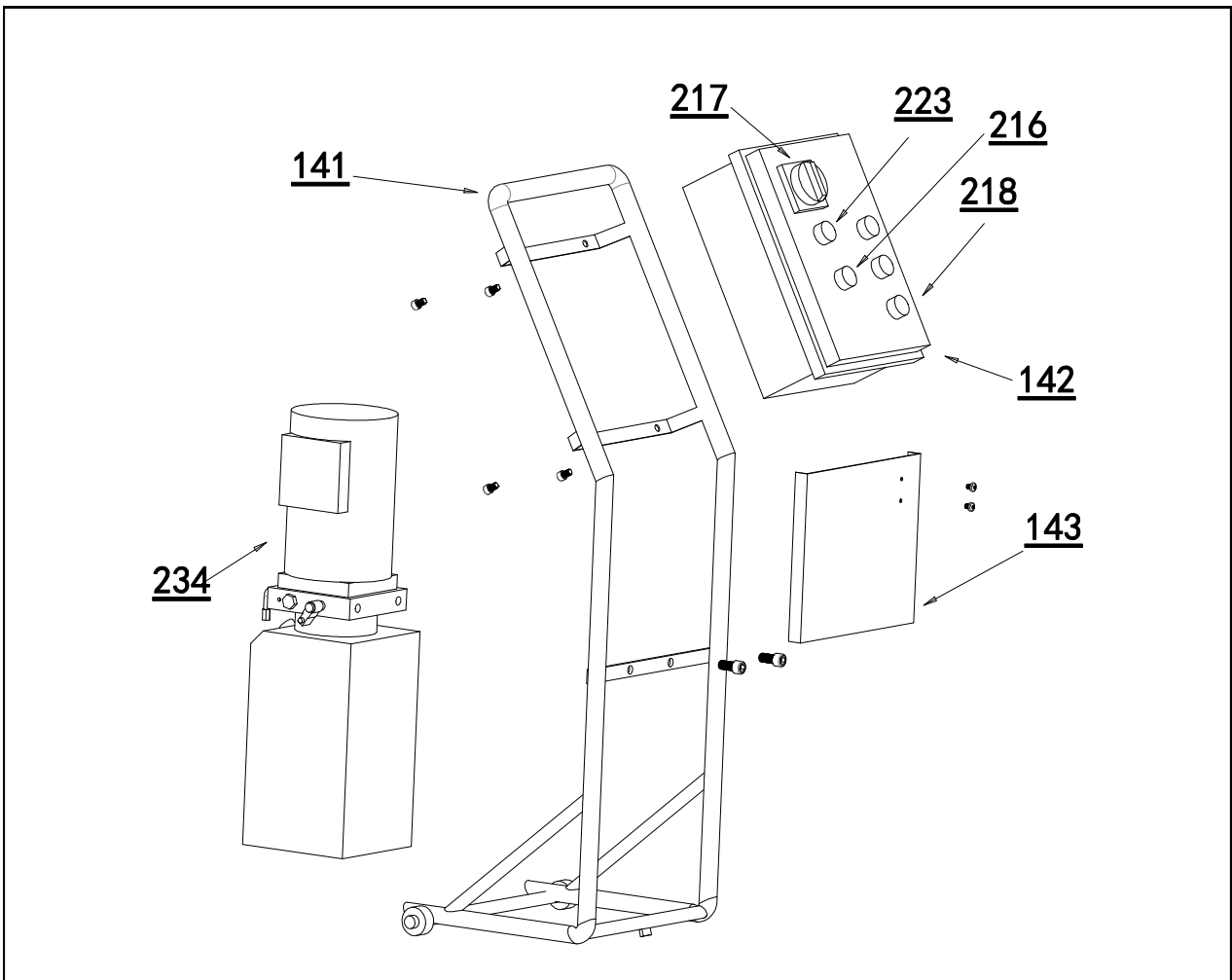
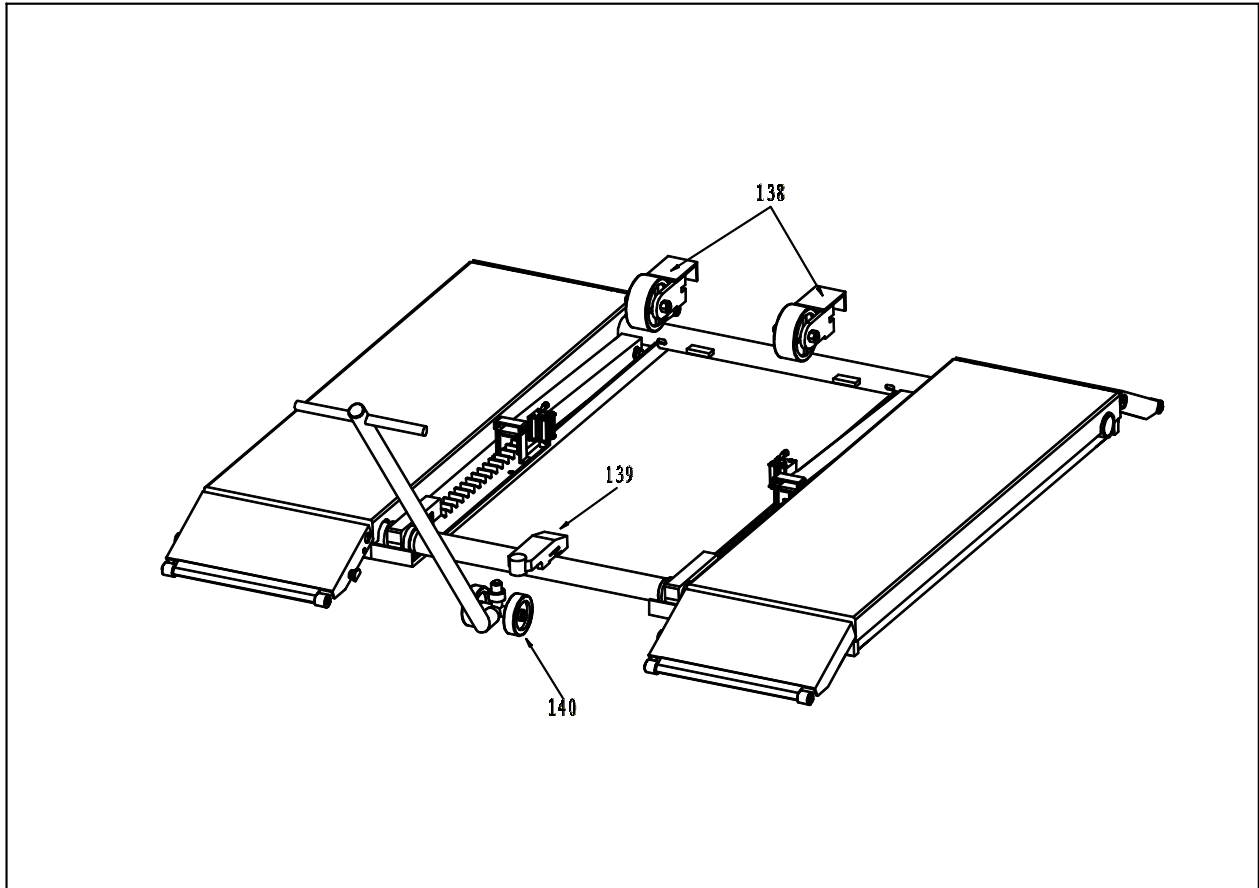
The request must be submitted to the authorized reseller as indicated in the front of the manual.

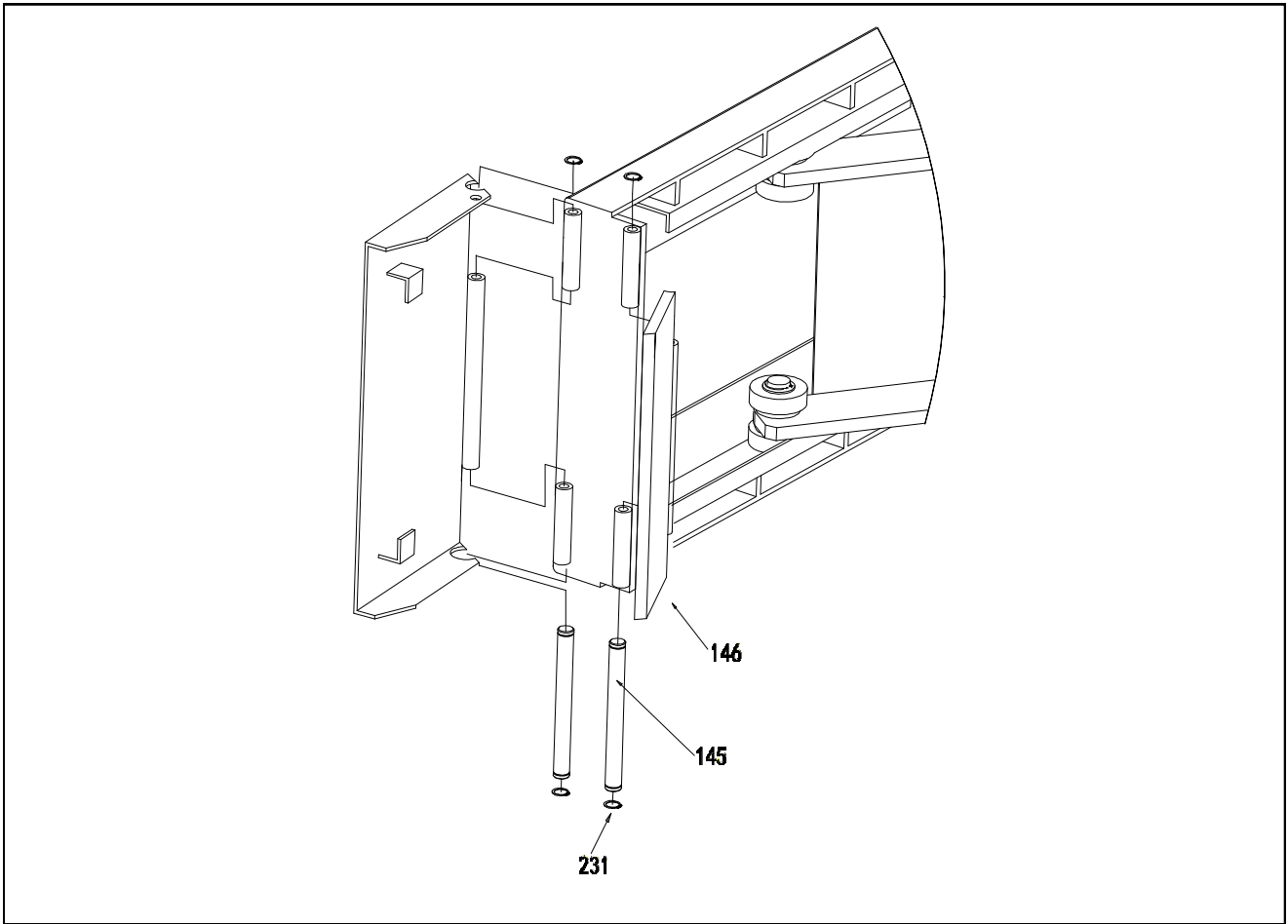
### B.3 SPAREPARTS LIST







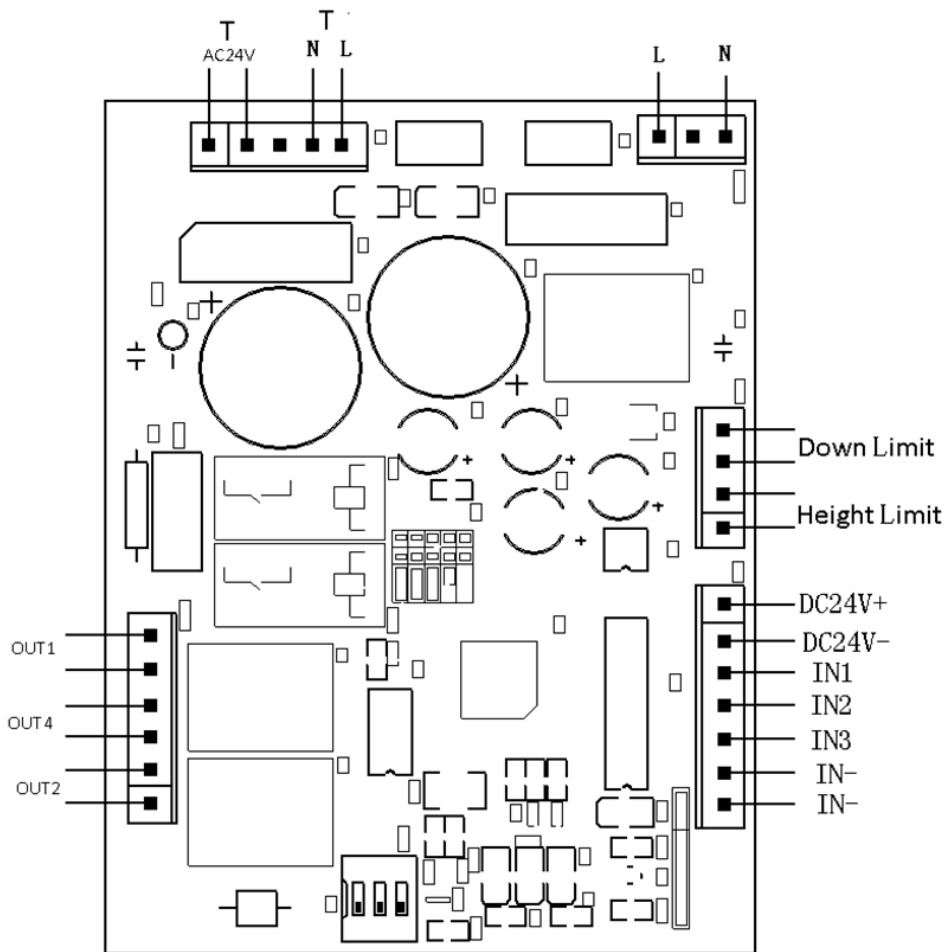
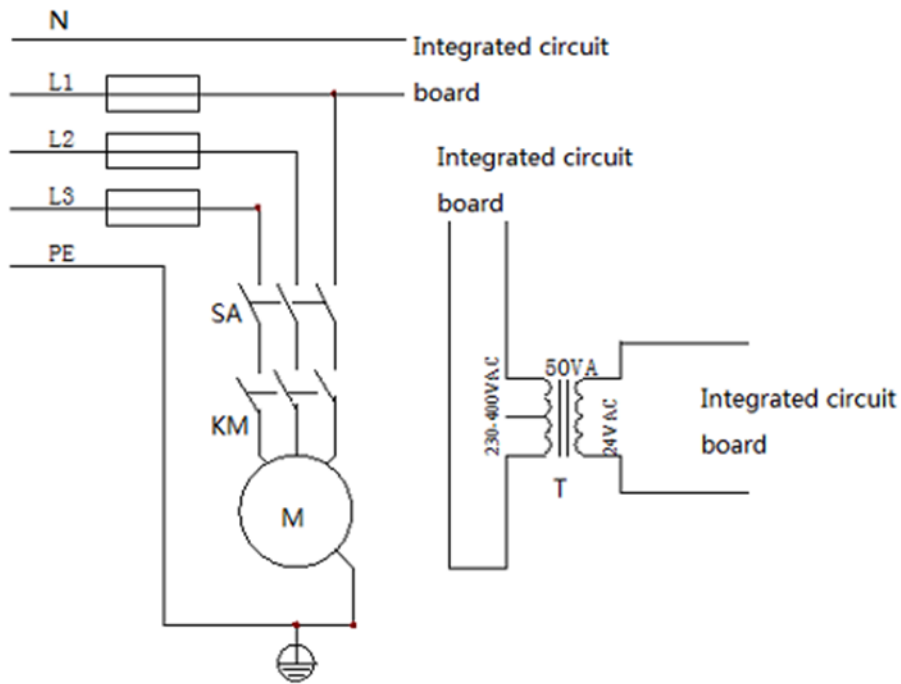




Code	Descriptions	Qty
101	Movable shaft	1
102	Bottom safety gear rack	2
103	Top safety gear rack spread groove	2
104	Connecting shaft	2
226	Clamp spring	4
105	Small cylinder intake bend	2
201	Small cylinder bolt	12
202	Guide frame bolt	12
203	Bottom safety gear rack strap bolt	20
106	Bottom safety gear rack strap	4
107	Top safety gear rack guide frame	2
108	Upper cover plate	2
110	Self lubricating bearing	4
111	Connecting shaft	4
112	Self lubricating bearing	8
225	Shaft clamp spring	16
113	Drive-up ramp	4
114	Connecting shaft	4
115	Connecting shaft roller	8
204	Outer clamp spring	8
205	Roller clamp spring	8
116	Upper cover plate sideway roller shaft	4
117	Lubricating bearing	8
118	Roller	8
119	Arm self lubricating bearing	4
120	Roller retaining ring	4
206	Shaft clamp spring	4
121	Oil cylinder upper fixed pivot connecting shaft	2
122	Self lubricating bearing	4
207	Nut	4
208	Split pin	4
123	Oil cylinder	2
124	Right angle connector	2
125	Oil pipe	3
209	Outer clamp spring	4

Code	Descriptions	Qty
126	Oil cylinder shaft	2
210	Nut	4
211	Split pin	4
128	Self lubricating bearing	4
129	Oil connector	3
130	Right angle connector	1
131	Self lubricating bearing	4
132	Support connecting sleeve	2
133	Positioning shaft	1
134	Bearing bracket	6
212	Bolt	12
135	Bottom plate	1
136	Bottom plate	1
137	Safety Fence	2
138	Wheel	2
139	frame	1
140	Wheel	1
214	Oil pressure table	1
215	Gas pressure table	1
141	Electric box	1
142	faceplate	1
216	pilot lamp	1
217	switch	1
218	button	3
143	Electric box door	1
219	bolt	4
220	Limiter switch	1
221	bolt	2
222	Limiter switch	1
144	Fixed plate	1
223	Buzzer	1
224	Gas connector	1

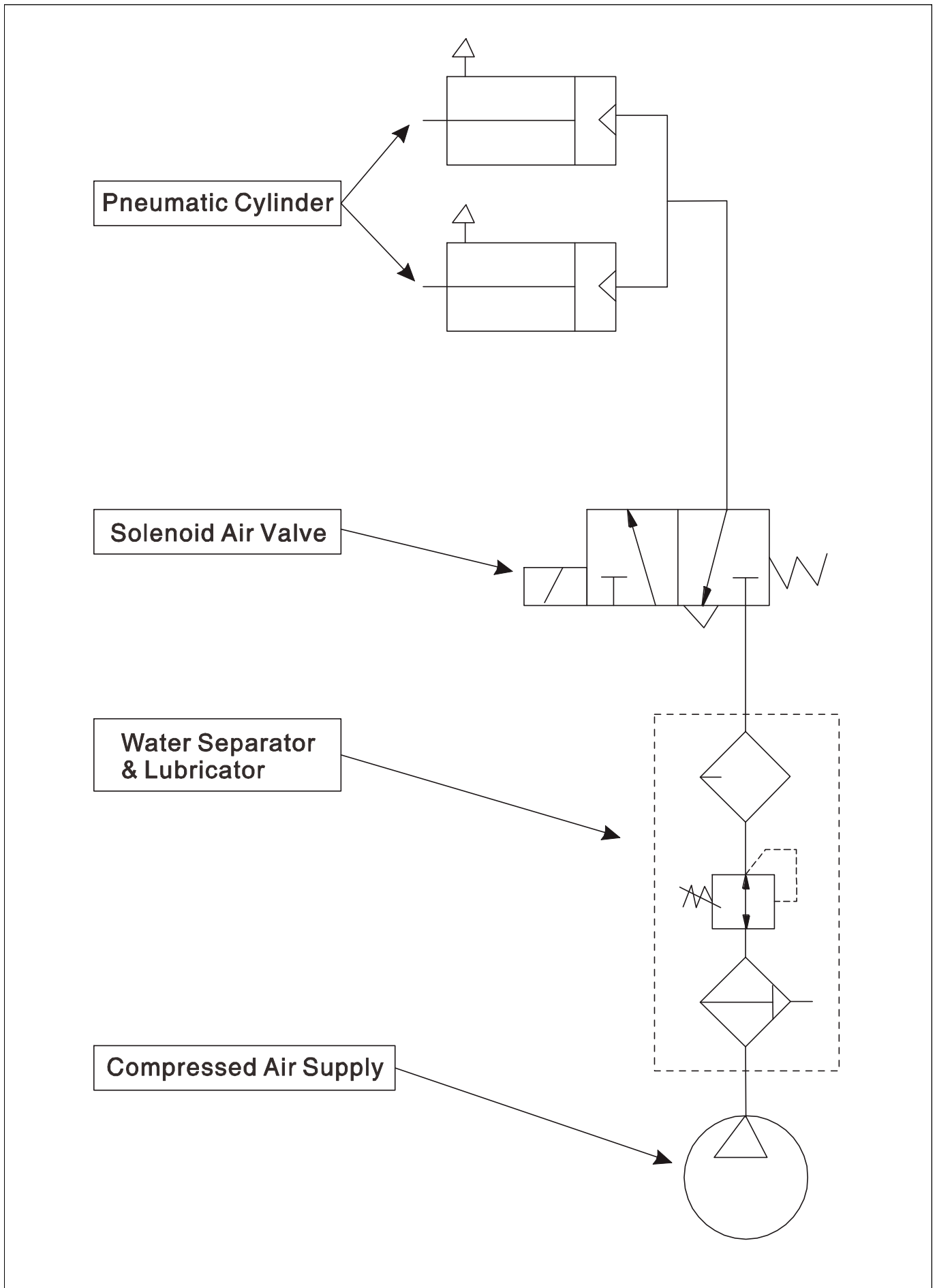
## APPENDIX C CIRCUIT DIAGRAM



IN1 and IN- -----UP  
 IN2 and IN- -----DOWN  
 IN3 and IN- -----LOCK

OUT1-----Contactor  
 OUT2-----Unlocking solenoid valve  
 OUT4-----Relief solenoid valve

## APPENDIX D PNEUMATIC SCHEMATIC DIAGRAM



## APPENDIX E HYDRAULIC PRESSURE SCHEMATIC DIAGRAM

