

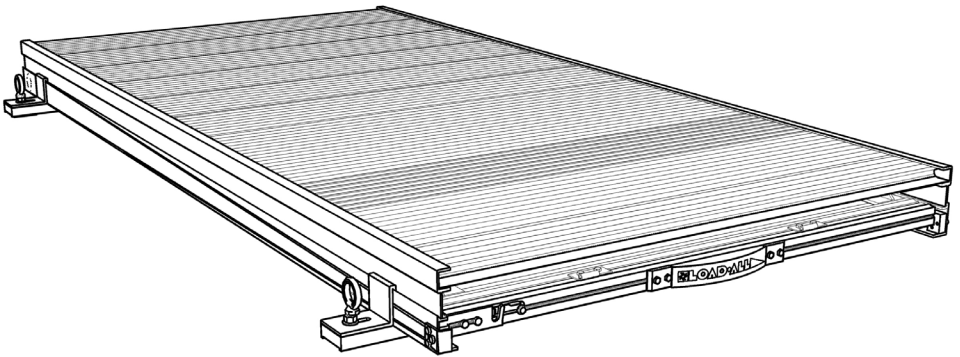

 InnerBox Loading Systems Inc.

V2 Series



2015 User Manual

LoadAll

InnerBox Loading Systems Inc.

3058 Eastern Ave.
Grand Rapids, MI 49508

1-877-241-4330 | info@loadall.com
www.loadall.com

V2 Series

2015 Loading System

Weight Capacity: 1,300 lbs.

WARNING

To avoid damage to equipment and reduce the risk of injury consult user guide for proper installation specifications and general use requirements. Failure to do so may result in the damage of equipment and/or serious injury/death.

*Patent Pending

Table of Contents

Overview	3
- System Overview	3
- Mounting Kit Inventory	4
Installation	5
- Hardware Configuration	8
- Shim Blocks	9
General Use	10
- Loading & Unloading	13
- Locks & Security	16
- Transportation	17
- Storage & General Care	17
Terms and Conditions	18
Warranty	21
- Product Registration	21

System Overview

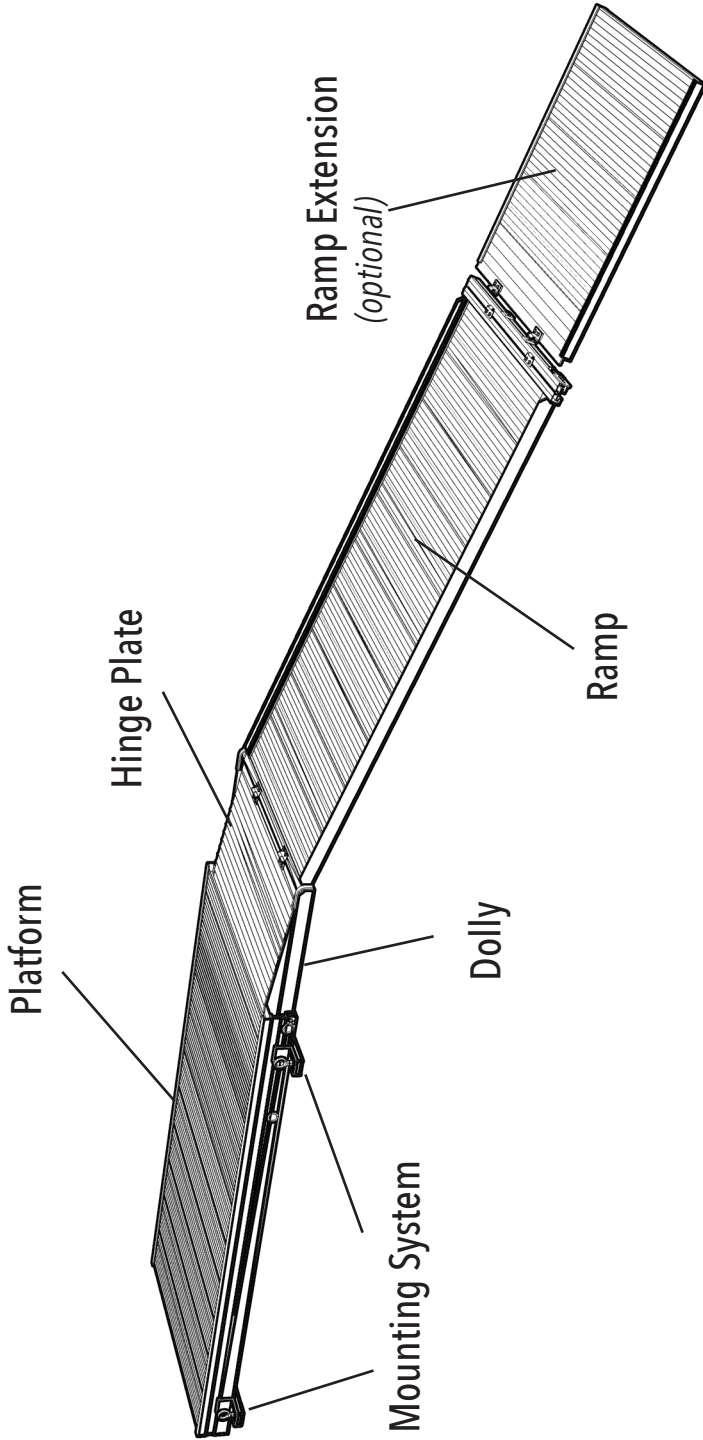

Mounting Kit:

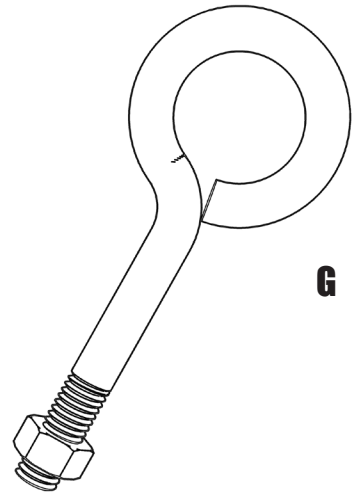
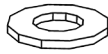
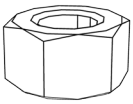
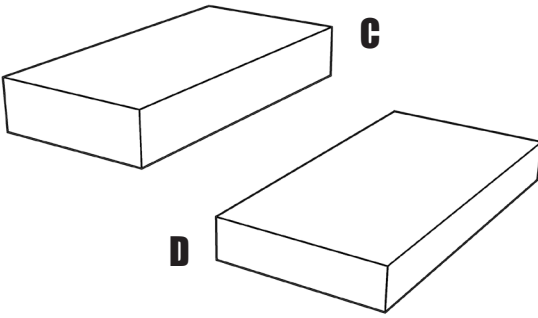
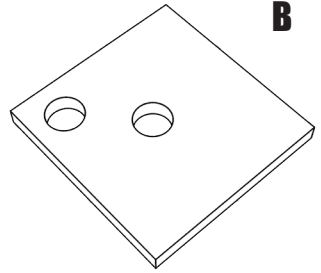
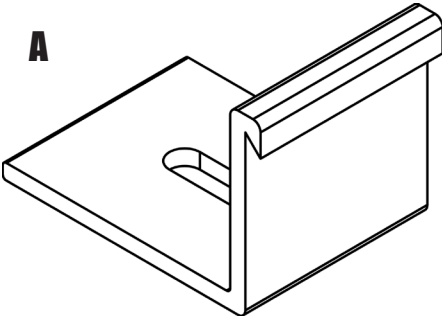

A) V2 Mounting Bracket (4x)	E) 1/2" Nylock Nut (2x)
B) Underbed Washer (4x)	F) 1/2" Flat Washer (4x)
C) 1" Shim Block (2x)	G) 1/2" x 6" Eyebolt (4x)
D) 3/4" Shim Block (2x)	

Installation Instructions

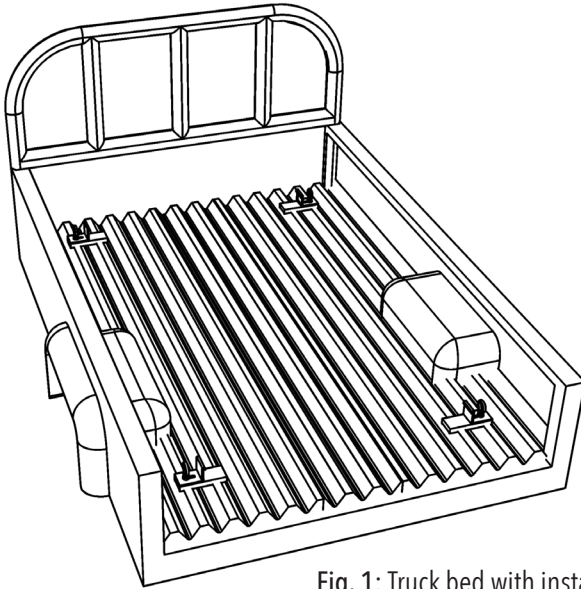

Fig. 1: Truck bed with installed Mounting Brackets

The first phase of installing your LoadAll V2 System is to bolt in the Platform and Mounting Kit to the truck bed. The Mounting Brackets are essential in securing the platform in place to prevent shifting during loading, unloading, transportation, and storage.

TOOLS NEEDED:

Powerdrill	1/2" drill bit
2x - 3/4" Socket and/or Wrenches	Long Screwdriver (optional)

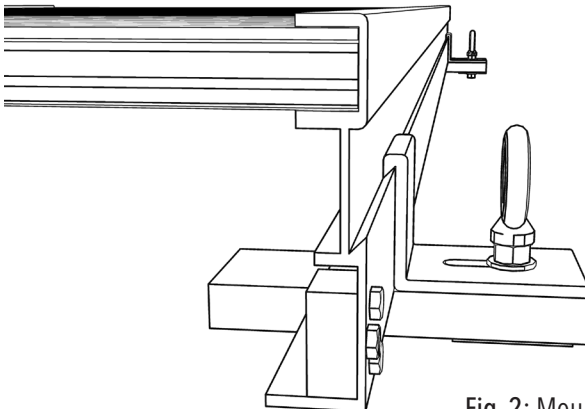

Fig. 2: Mounting Brackets installed & attached

STEP 1: Determine vertical centerline of truck bed and place marks in the front and rear of truck bed:

$$[\text{Truck Bed Width}] \div 2 = \text{Centerline Dimension}$$

STEP 2: Place the Platform in the Truck Bed between the wheel wells with the Mounting Brackets and Shim Blocks.

TIP: To decrease the overall weight of system - Remove Ramp, Hinge Plate, and Ramp Extension (if included) from the Dolly and set aside until Platform is installed.

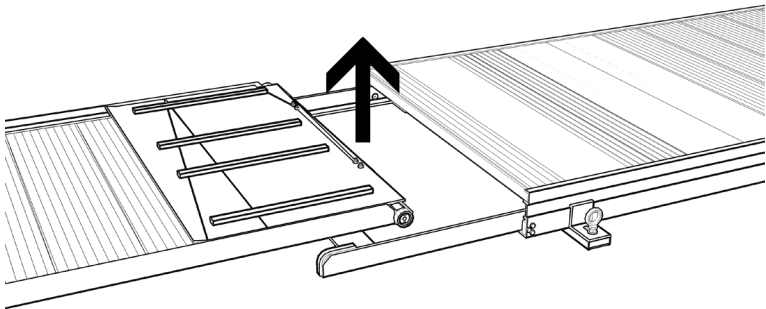
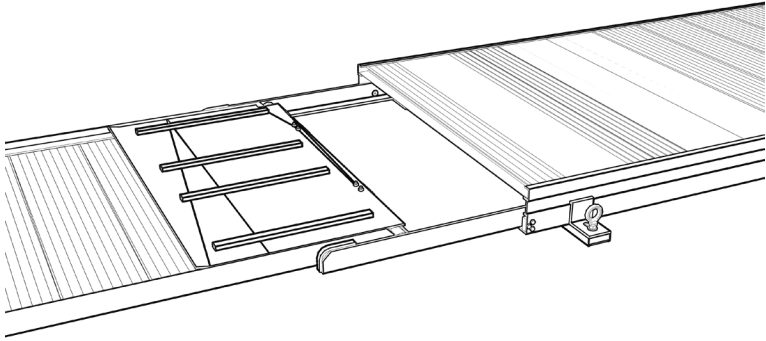

STEP 3: Close the Tailgate and align the Platform to the previously drawn centerline

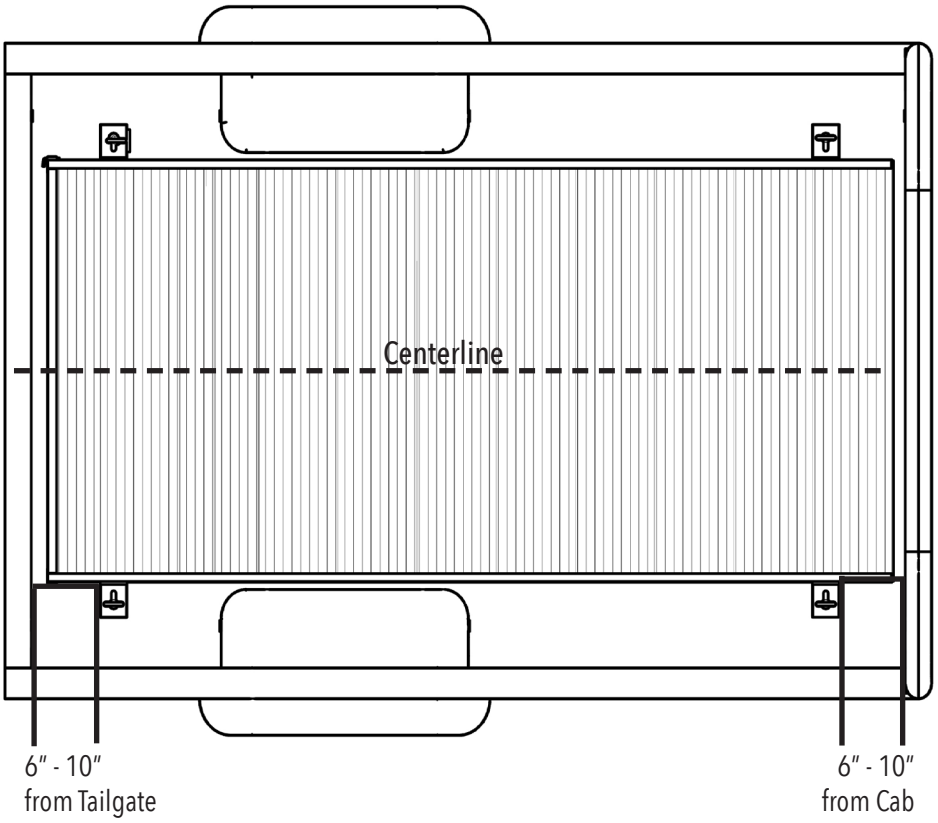

STEP 4: Position each Mounting Bracket and Shim Block 6 - 10 inches away from the Tailgate and Cab at each corner of the Platform.

1" Shim Blocks near the Tailgate

3/4" Shim Blocks near the Cab

Brackets should attach to the outside of the Platform's siderails with included hardware in the following configure (page: 8)

Hardware Configuration:

Install each Mounting Bracket using included hardware as follows:

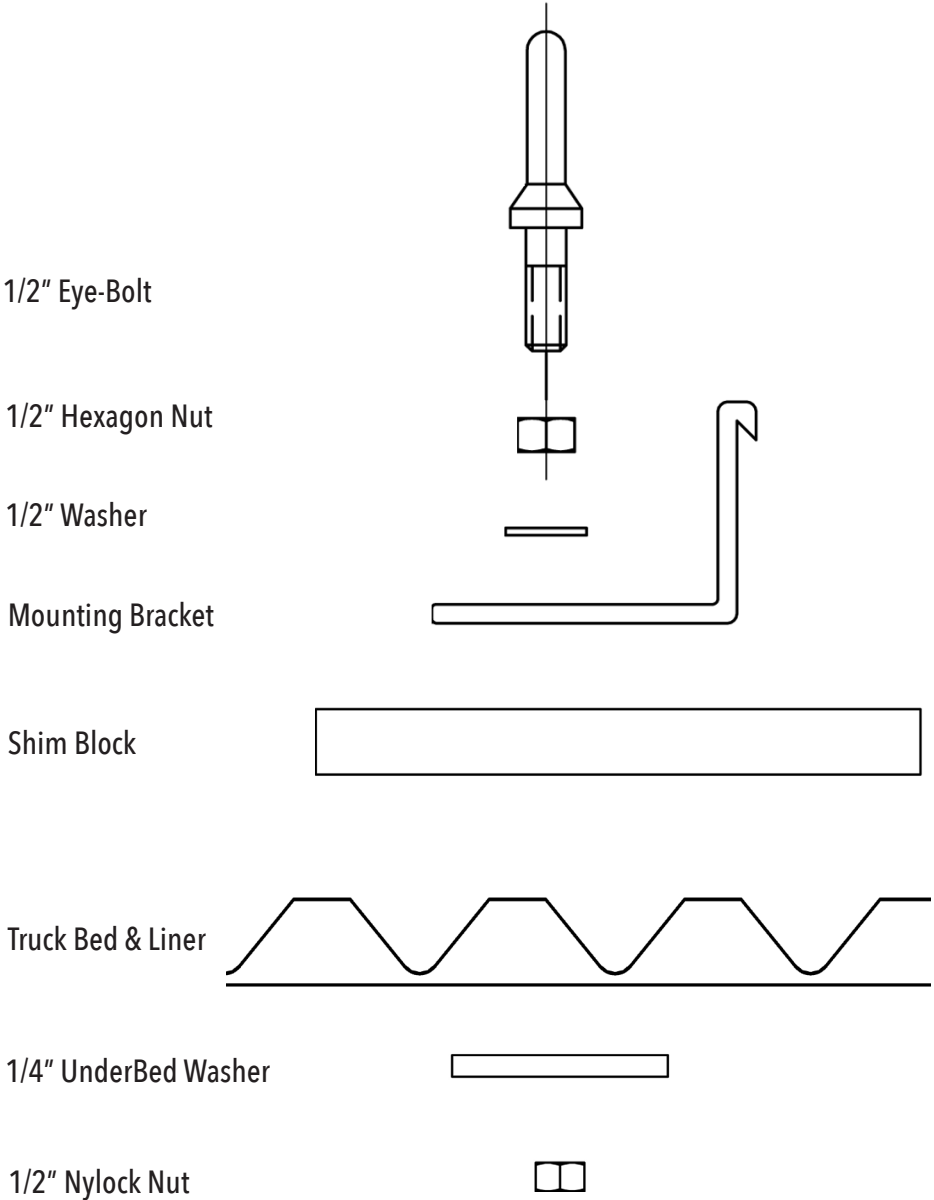

Shim Block: Positioning & Puncturing

The Shim Blocks act as a support riser for the mounting brackets and Platform so the system never rests solely on the truck bed or tailgate and prevents the mounting brackets from tipping or buckling. To do this the Shim Block needs to be positioned so BOTH edges are supported by the ridges of the truck bed and liner.

The location and position will vary depending on type of truck and bed liner. Because of this the Shim Block's are left *undrilled* to allow for a custom installation for maximum functionality.

To determine the appropriate hole location position each Shim Block across the truckbed or liner ridges as shown below:

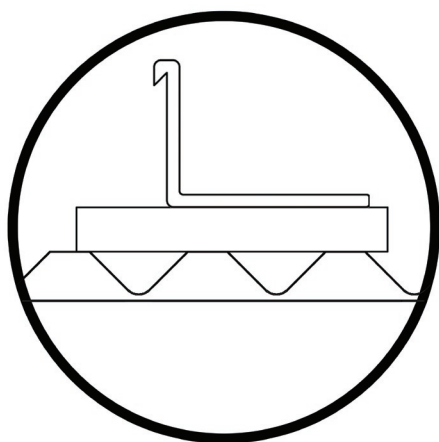

CORRECT

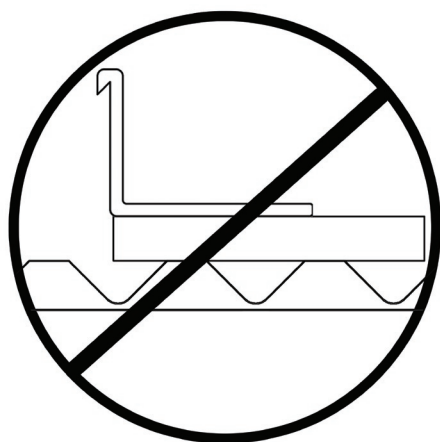

WRONG

STEP 4: Position the Shim Block under the Platform and Mounting Bracket and brace the Shim Block and Bracket for drilling

STEP 5: Using the Mounting Bracket as a guide - Drill the appropriate holes using a 1/2" bit through the shim block, truck bed and liner.

STEP 6: Attach Mounting Bracket with included hardware. (see **Page: 9** for proper configuration)

STEP 7: Continue placing and attaching the remaining Brackets in the same configuration as described on **pages 7-9**.

General Use

LoadAll's allow for a safe, convenient, and efficient way to load and transport a variety of equipment. For proper loading and unloading guidelines please review the following instructions. All mounting brackets, shim blocks, stop blocks, and locks should be attached and secured prior to any loading process.

STEP 1: Drop the Tailgate and unlock the Ramp from the Platform cavity. Using the Handlestrap, pull the Ramp out of the Platform with the Dolly until the Dolly Wheels hit the plastic Stop Blocks inside the Platform.

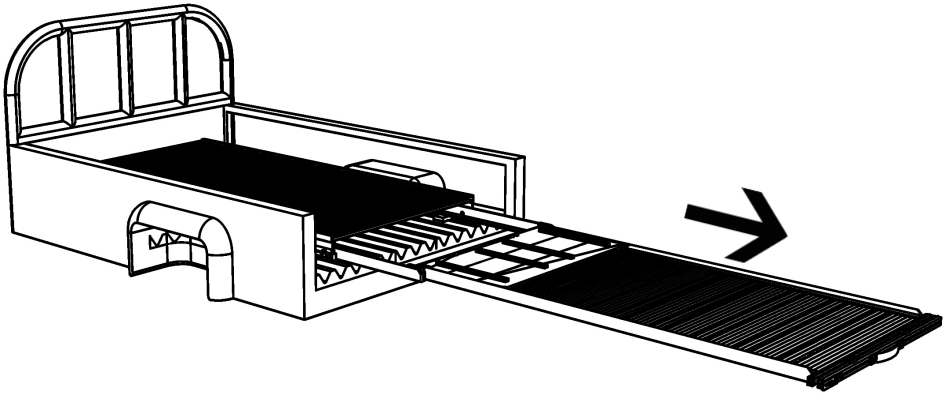

STEP 2: With the Ramp and Dolly pulled out, lower the Ramp to the ground. If a Ramp Extension is included, insert Ramp Extension Legs as shown below and lower to the ground.

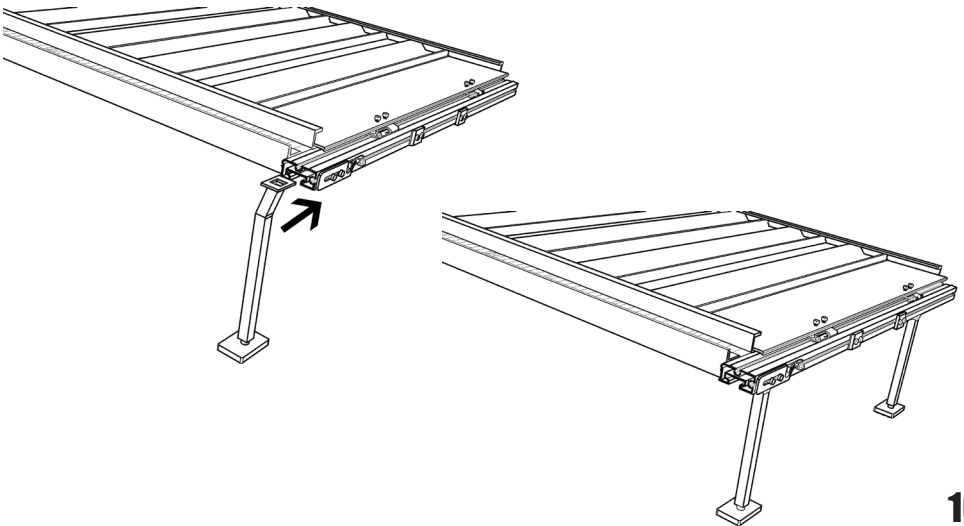

STEP 3: Unfold Hinge Plate at the top of the Ramp to bridge the gap between the Ramp and Platform

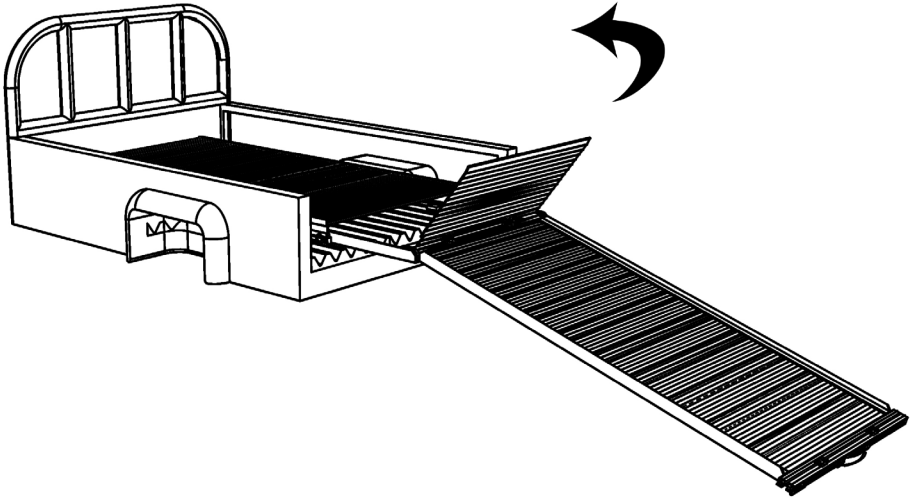

STEP 4: If included, unfold the Ramp Extension at end of Ramp to fully extend the Ramp assembly

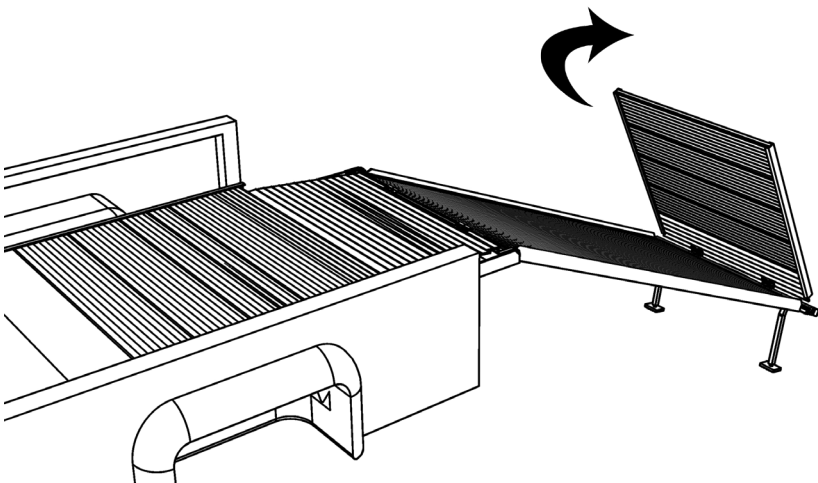

V2-800 Set-Up Complete:

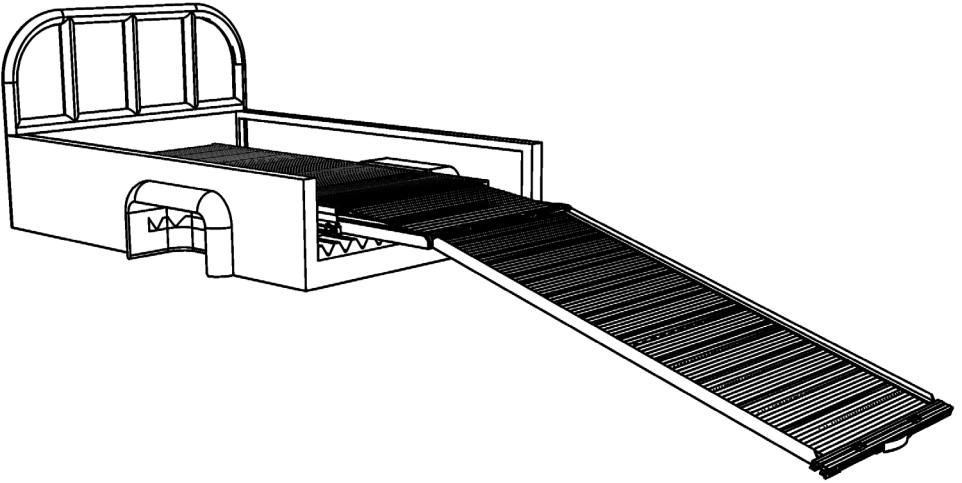

V2-800 Set-Up Complete (with Ramp Extension):

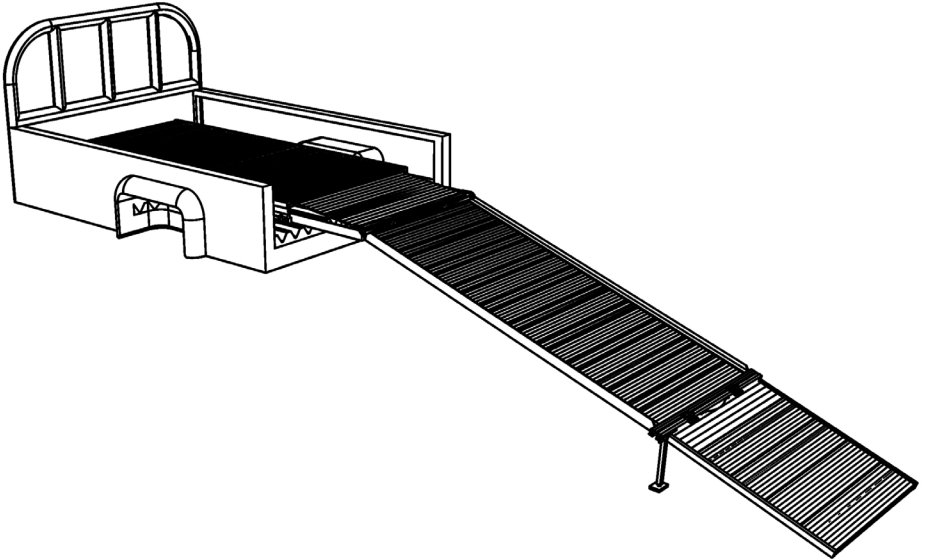

Loading & Unloading

All LoadAll System's are able to support the loading and transportation of a variety of equipment including, but not limited to:

- Motorcycles (1-2)
- Snowmobiles
- Appliances
- ATV's / Four-wheelers
- Riding Lawn Mowers
- And more... (up to 1,300 lbs.)

To load your equipment be sure the platform is secured to the truck bed with the mounting system and all assemblies are fully extended and secured.

STEP 1: Position equipment facing the ramp and begin the ascent up the Ramp at a slow, steady pace - aiming for the middle of the truck cab.

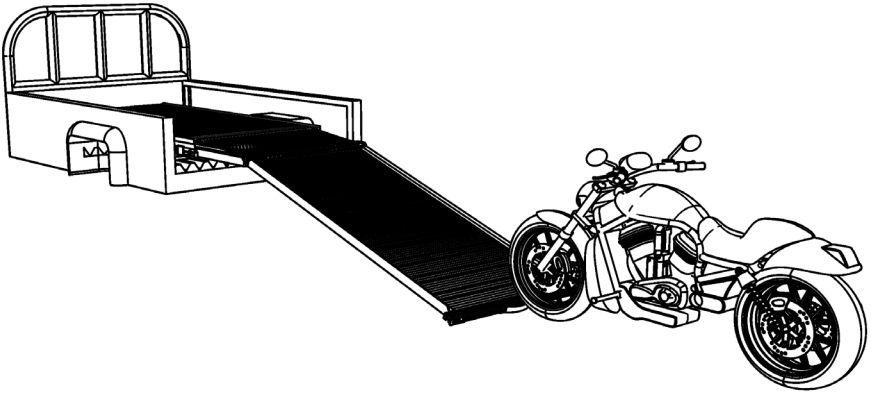

Loading 2 Bikes: stay in the center of the ramp until front tire is on the platform then turn off to either side to make room for the second.

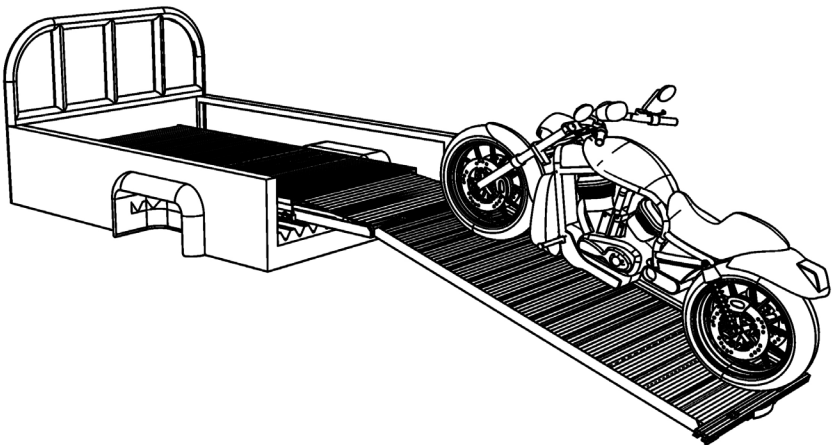

Once all wheels are positioned on the Platform *lightly* secure in place and begin collapsing the system.

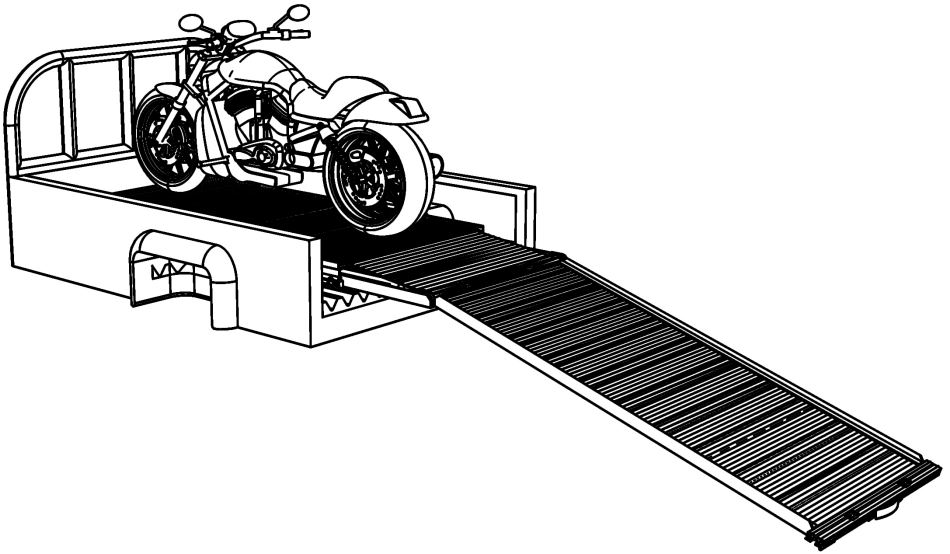

STEP 2: Fold Hinge Plate and Ramp Extension (if included and remove legs) back onto Ramp.

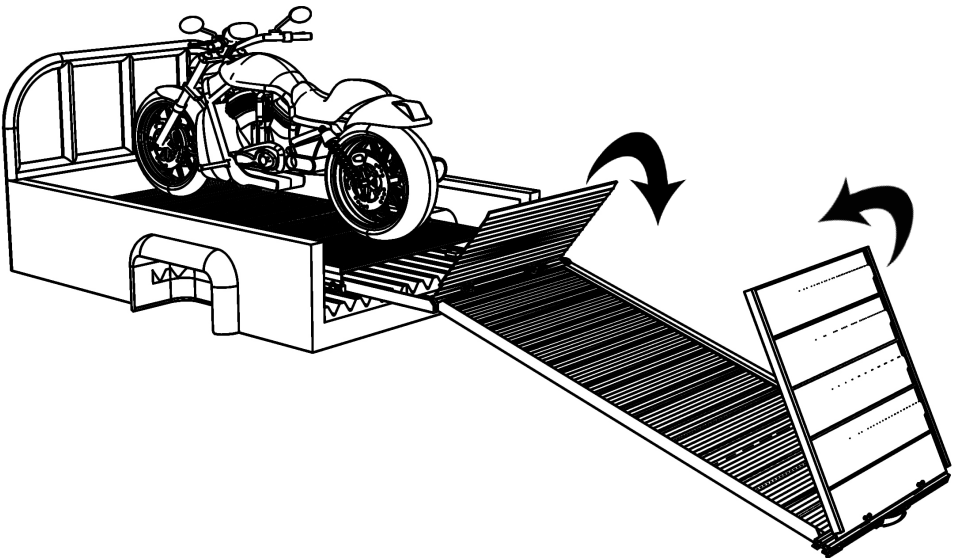

STEP 3: Bring Ramp and attachments up, parallel with Platform and slide into the Dolly and Platform Cavity

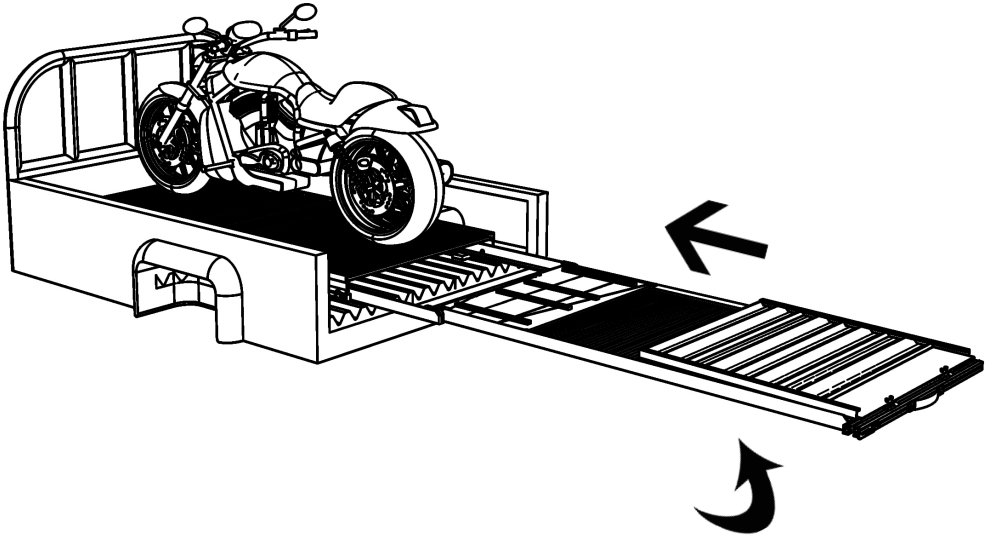

STEP 4: Once inserted, lock the Ramp in place as shown (page: 16) and finish tying down any equipment for transportation.

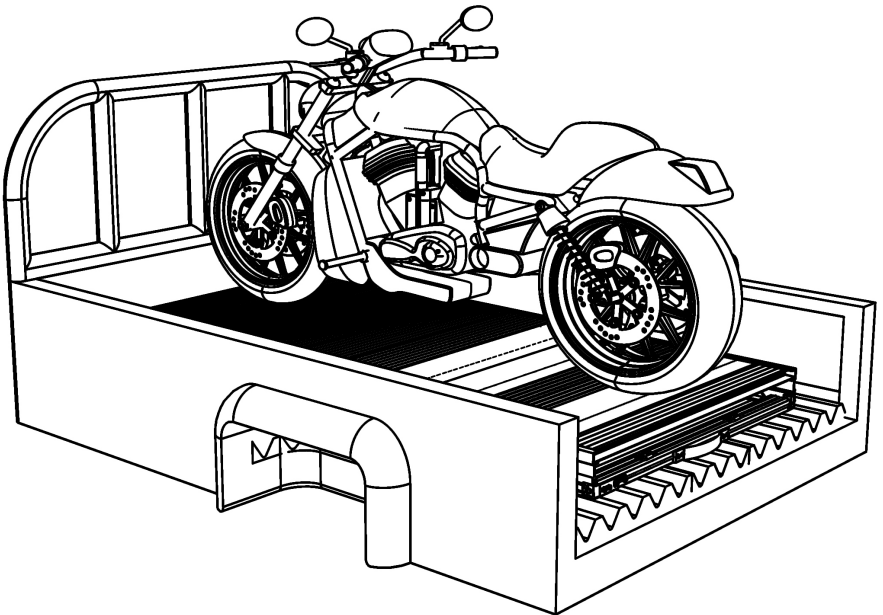

Ramp Lock

To ensure the Ramp and its attachments remain inside the Platform during use or storage always have the lock in place and secure. When unlocked*, be sure the side lever is down and holding the bracket in place.

**Failure to do so may result in part damage.*

Fig. 1:
Ramp Locked

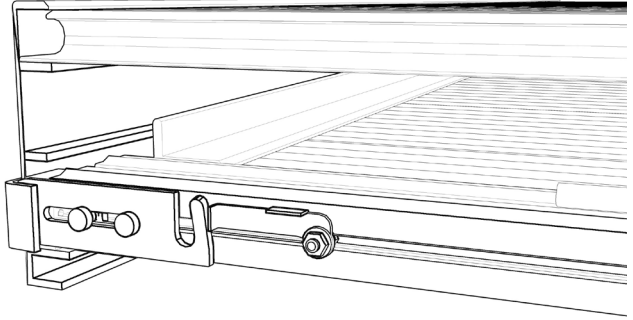

Fig. 2:
Lock-Catch Open

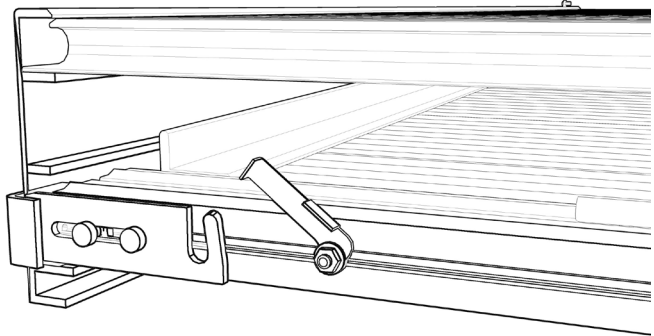
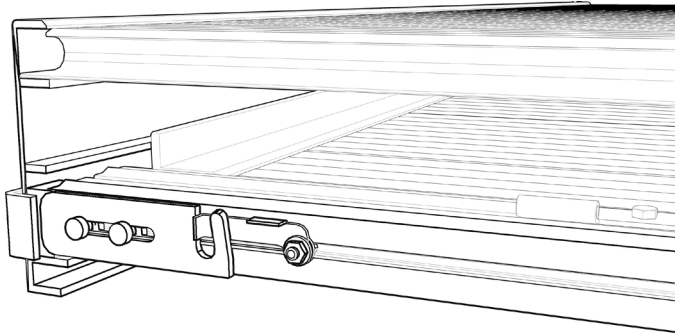

Fig. 3:
Ramp Unlocked



Transportation

Along with securing your Ramp in place with the Ramp Lock you will also need to **secure your equipment**. It is recommended to use at least (2) tie down straps to secure riding equipment and should be increased depending on the type of load in addition to other travel variables (i.e. weather, travel terrain, load quantity, personal preference).

DO NOT overtighten your equipment prior to storing your Ramp - Lightly tighten, store the Ramp, and finish tightening/securing your equipment prior to any traveling or transporting.

Storage & General Care

When not in use the V2 LoadAll will store behind the tailgate, allowing the tailgate to close and any bed cover to be used as intended. To maintain a smooth slide for the Ramp and Dolly it is recommended to clean the track periodically to remove dirt and grime (i.e. standard aluminum cleaner, all purpose cleaner, WD-40, etc.)

Systems can be left in the bed for all seasons or can be removed and stored either flat or upright against a wall.

Mounting Hardware can remain in the bed, removed for later use, or can be re-installed in another truck bed if desired. Additional Mounting Kits available for purchasing. Please visit www.loadall.com or call our Grand Rapids sales office for ordering information.

Terms & Conditions

- 1. ORDERS:** All orders are subject to acceptance by Seller. These terms and conditions are applicable and are an integral part of purchase orders resulting from Seller's quotations. These terms and conditions shall govern and supersede any terms and conditions integrated and/or supplied by the Buyer, unless separately agreed to in writing by both the Seller and the Buyer. Seller's failure to object to provisions contained in any communication from Buyer shall not be deemed a waiver of these terms and conditions.
- 2. VALIDITY:** All quotations submitted are valid for fifteen (15) days from the date of the quotation unless otherwise stated on the face of the quotation. Until accepted by Buyer, the quotation is subject to change within the validity period.
- 3. PACKAGING:** Standard commercial packaging is included in the quoted price. Special packaging will be provided at Buyer's expense when specified. Reasonable care is exercised in packaging goods for shipment and no responsibility is assumed by Seller for delay, breakage or damage after delivery to the carrier. Buyer will file any claims for breakage or damage directly with the carrier. Seller will render reasonable assistance in securing satisfactory adjustment of such claims.
- 4. TITLE AND DELIVERY:** All sales are F.O.B. origin unless otherwise agreed to in writing by the Buyer and Seller. Title and risk of loss pass to Buyer upon delivery to the carrier at shipping point. Unless shipment method is specifically directed from the Buyer, Seller will exercise its own discretion. Shipping dates are approximate and are based upon prompt receipt of all necessary information from Buyer. In the event of any default by Buyer, Seller may decline to make further shipments.
- 5. INSPECTION & ACCEPTANCE:** Buyer must inspect the goods within ten (10) days after delivery, and give written notice to Seller of any products being rejected; describing the product and details as to the reason the product is being returned. Returned product will be processed under the Seller's Warranty provision. Buyer will have irrevocably accepted any and all products if Buyer has failed to give Seller written notice of rejection within the 10-day period. Buyer's inspection and/or acceptance tests shall not exceed the inspection and/or test procedures customary in the industry for the products delivered by Seller. Seller may charge to Buyer any costs resulting from the testing, handling and disposition of any products returned by Buyer which are not found by Seller to be nonconforming.
- 6. PAYMENT:** Upon credit approval, terms of payment shall be net thirty (30) days from date of the invoice. Credit may be changed or withdrawn by Seller at anytime. If credit is not extended, payment will be required in full prior to shipment. In the event Buyer becomes the subject of a bankruptcy or other insolvency proceeding, or fails to pay Seller's invoices as they become due, Seller may cancel any order outstanding and receive reimbursement for cancellation damages. Each shipment shall be considered a separate independent transaction, and payment thereof shall be made accordingly. If shipment is delayed by Buyer, Seller may invoice on the date when Seller would have made shipment but for the delay. All invoices shall be paid within the term stated, even if product has been returned under the Seller's Warranty provision. Buyer is not authorized to make reductions on the invoice without prior written approval of Seller. Buyer will pay a delinquency charge in the amount of 1½ % per month (18% per annum) on overdue amounts, in addition to all amounts otherwise due Seller available by law.
- 7. TAXES:** Buyer agrees to pay all applicable federal, state, and local taxes, duties and other fees on product and services ordered.
- 8. SELLER'S WARRANTY:** LIMITED WARRANTY: IT IS EXPRESSLY AGREED THAT NO WARRANTY, OF MERCHANTABILITY, WARRANTY OF FITNESS FOR A PARTICULAR PURPOSE, NOR ANY OTHER WARRANTY (EXPRESS, IMPLIED OR STATUTORY) IS MADE BY SELLER, EXCEPT THAT SELLER WARRANTS THE GOODS TO BE FREE FROM DEFECTS IN MATERIALS AND WORKMANSHIP.
Seller will replace, repair, or issue credit, at their option, any product returned under warranty by the

(8. SELLER'S WARRANTY CONT.) the product to the Buyer. All transportation charges will be the obligation of the Buyer. The warranty period will be one (1) year from the date of shipment for all Standard products unless otherwise indicated in the quotation. Seller will not be liable for loss of profit, loss of use, incidental damages, consequential damages or any loss, cost, or damages of any kind based upon a claim for defective products or breach of warranty.

9. CHANGES TO SPECIFICATIONS: Seller reserves the right to change the specifications of any product without notice. If specifications are changed, Seller assumes no obligation to provide the change on products previously purchased or to continue to supply discontinued products or versions. Seller may substitute products or components of equivalent or higher performance.

10. ASSIGNMENT: Buyer will not assign its order or any interest therein or any right thereunder without the prior written consent of Seller.

11. GOVERNING LAWS: Irrespective of the place of performance, this contract will be construed, and interpreted according to the laws of the State of Michigan, and Buyer consents to jurisdiction in the State of Michigan.

12. TERMINATION: Buyer will be liable for Seller's costs incurred, plus a reasonable profit, for the portion of the work terminated, in accordance with generally accepted accounting principles, together with cancellation charges. Some orders may be subject to a minimum cancellation fee. Seller reserves the right to cancel all or part of any order accepted if inaccurate or incorrect information is supplied by Buyer, which in Seller's judgment, affects the order, or otherwise materially changes the rights or responsibilities of Buyer and/or Seller.

13. OWNERSHIP DATA RIGHTS / PATENTS:

The sale of products or any parts thereof hereunder confers upon Buyer no license, express or implied, under any patent rights of Seller. Any invention, discovery, proprietary information, software, system, data, or report resulting from the work performed under this quotation or resulting order, will be the sole property of the Seller. All patents, copyrights, trade secrets, trademarks, or other intellectual property resulting from work under this quotation or resulting order shall be the sole property of the Seller. Seller shall have the full right to use such property in any manner without any claim on the part of the Buyer and without any duty to account to the Buyer for such use. Buyer agrees to assign to Seller any patent or patent application resulting from work performed under this quotation or resulting order.

14. LIMITATION OF LIABILITY: LIABILITY OF SELLER TO BUYER FOR DAMAGES FOR ANY CAUSE WHATSOEVER, AND REGARDLESS OF THE FORM OF ANY ACTION INCLUDING, BUT NOT LIMITED TO NEGLIGENCE, SHALL BE LIMITED TO THE PRICE SPECIFIED IN THE SALE CONTRACT FOR THE SPECIFIC PRODUCT OR PRODUCTS THAT HAVE CAUSED THE DAMAGES, OR ARE DIRECTLY OR INDIRECTLY RELATED TO THE CAUSE OF ACTION. IN NO EVENT SHALL SELLER BE LIABLE TO BUYER OR OTHERS FOR LOSS OF GOODWILL, LOSS OF PROFITS, LOSS OF USE OR OTHER SPECIAL COLLATERAL, INCIDENTAL OR CONSEQUENTIAL DAMAGES, REGARDLESS OF THE FORM OF ACTION THEREOF, INCLUDING BUT NOT LIMITED TO NEGLIGENCE, EVEN IF SELLER HAS BEEN ADVISED OF THE POSSIBILITY OF SUCH DAMAGES OR FOR ANY CLAIM AGAINST BUYER BY ANY THIRD PARTY. BUYER ASSUMES ALL LIABILITY FOR ANY AND ALL DAMAGES ARISING FROM OR IN CONNECTION WITH, THE USE OR MISUSE OF THE PRODUCTS BY BUYER, ITS EMPLOYEES, OR OTHERS. NO OBLIGATION OR LIABILITY OF SELLER WILL ARISE OUT OF SELLER RENDERING OF TECHNICAL ADVICE IN CONNECTION WITH BUYER'S ORDER OR THE PRODUCTS FURNISHED HEREUNDER.

15. FORCE MAJEURE: Seller will not be responsible or liable for any delay or failure in performance arising as a result of fire, accident, acts of God, acts of public enemy, war, labor disputes, failure or delays, transportation, inability to secure product, raw materials or machinery for the manufacturing process, requirements or acts of any government or agency thereof, judicial action or other causes beyond Seller's control.

16. CONFIDENTIAL INFORMATION: All drawings, diagrams, specifications, technical information, and other material and information furnished by Seller and identified as confidential (hereinafter collectively called "Confidential Information") is proprietary to Seller and contains trade secrets. Buyer shall

(16. CONFIDENTIAL INFORMATION CONT.) not use, reproduce, distribute or disclose such Confidential Information, except that Confidential Information may be disclosed, with appropriate safeguards against re-dissemination, to employees of Buyer with respect to whom such information is necessary to the performance of their duties hereunder. Buyer recognizes that such proprietary information is unique and consents to the remedy of injunction in addition to damages for a violation of this provision.

17. PROHIBITED USES: Buyer may not in any way; modify the product (except as permitted in the normal use of the product), reverse engineer, disassemble, or make any attempt to copy the product or transfer the product to any person or entity.

18. EXPORT CONTROL: Buyer will comply with all export control laws and regulations of the United States Government and with any applicable laws and regulations of any other country. Buyer agrees not to export or re-export either directly or indirectly any technical data furnished hereunder or the direct product of such technical data to any country which, as set forth in the Export Administration Regulations of the United States Department of Commerce, is prohibited.

19. All Sales Are Final / Returns

If product is found to be defective customer has ten days from date of purchase to notify manufacture of product for an Rma. All systems Approved for return are subject to a \$500.00 five hundred dollar restocking fee if returned freight pre-paid within seven days. If no defect or damage are found due to manufacturing. Manufacturer will not accept any returns on custom systems or be responsible for any injury caused by using any custom system. Buyer accepts all responsibility on contacting the manufacturer for any RMA within the time stated .shipping damage should be brought to the attention of the carrier as inspection of all components of system are the responsibility of buyer before signing for shipment.

Warranty

All LoadAll system's come with a standard **2 Year Warranty** that covers the repair or replacement for any part or assembly failures due to manufacture defects. This does NOT cover system failure due to negligence, overloading, and/or post-manufacture modifications.

To redeem your warranty offer preserve your original LoadAll receipt and register your product with us by filling out a product registration form and mailing it in OR submitting one online at:

www.loadall.com

Mail Product Registration Form to:

LoadAll InnerBox Loading Systems

3058 Eastern Ave.

Grand Rapids, MI 49508

OR

Email to: orders@loadall.com

PRODUCT REGISTRATION FORM

Please fill out this product registration form to secure your warranty from its original date of purchase. *KEEP YOUR ORIGINAL RECEIPT*

Name: _____

Address: _____ City: _____

State: _____ Zip Code: _____

System Model: _____ Custom (size): _____

Serial Number (Located on Hinge Plate): _____

Date Of Purchase: ____/____/____





InnerBox Loading Systems Inc.

3058 Eastern Ave.
Grand Rapids, MI 49508

1-877-241-4330 | info@loadall.com

www.loadall.com