

LAZY MAISONS HEIGHT ADJUSTABLE TABLE

STRAIGHT 3 STAGE T LEG BASE

Model Number : LM-BZS3

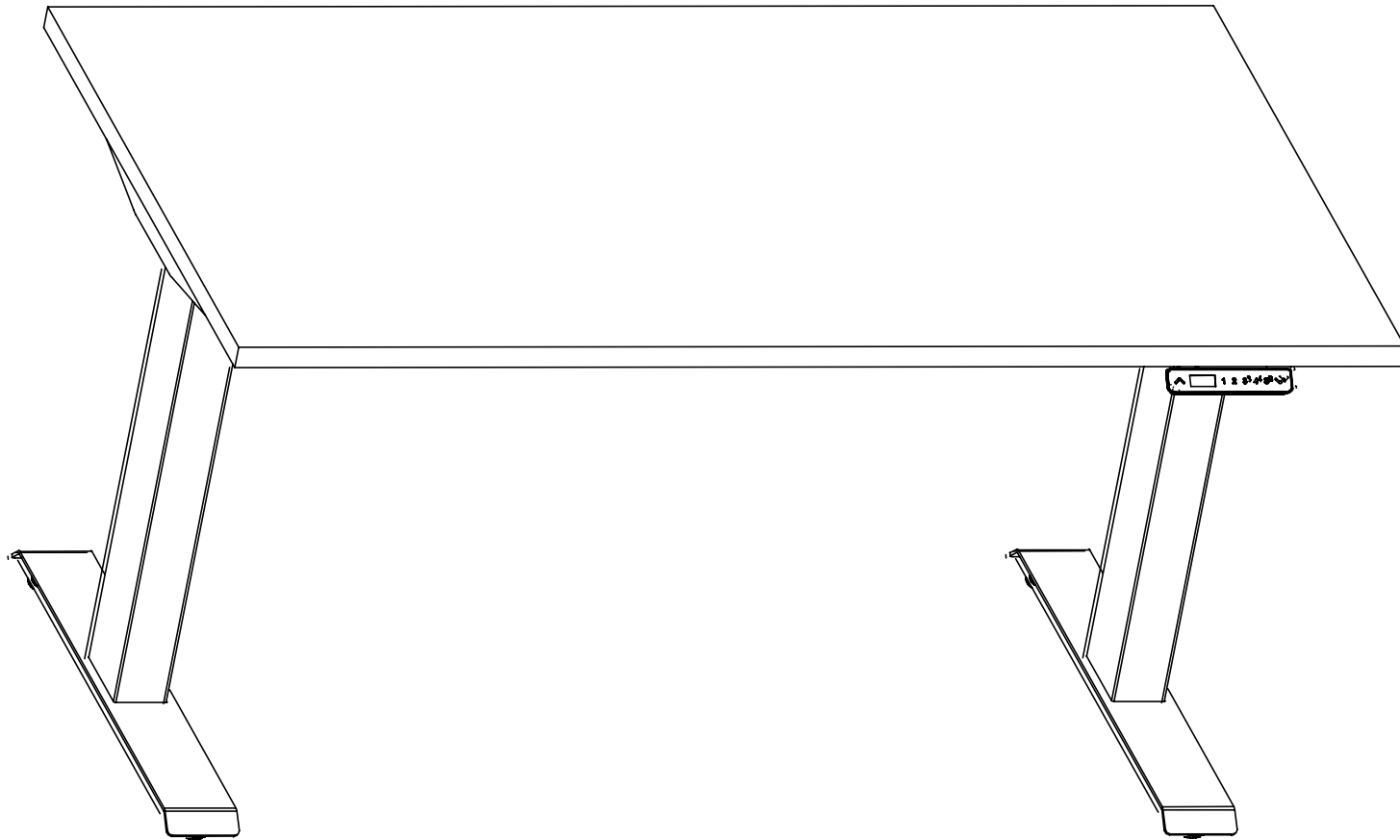

Please Read Instructions Before Use

ASSEMBLY INSTRUCTIONS

Thank you for choosing us. We appreciate the trust and confidence you have placed in us and are committed to providing you the best possible product.

Tools Needed

Introduction

We offer a comprehensive line of office furniture for every space and requirement, now including My-Hite, a height adjustable table that allows for standing or sitting while working.

User Notes

1. As with all power-operated products, please follow instructions closely and handle with care.
2. When moving tables, please lift the tables, do not drag or tilt the table on one leg as misalignment may occur.
3. Check that the load on the table does not exceed limits (120kg maximum on straight).
4. The input voltage should be within 100-240V.
5. Use the glides to properly level the table before use. Table should be level and aligned at all times.
6. Before first use, perform reset operation.
7. If, after trouble shooting the problem persists, contact Customer Service for further assistance.



Single Sided
Wrench



Socket Head
Wrench

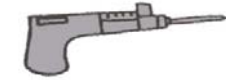

Electric Drill

We do not assume any responsibility for product that is altered in any way.

1



1. Read instructions carefully. Check that no parts are missing.

2



2. Carefully identify each component, especially those that are similar. The most common mistake is mixing up the order and placement of parts.

Parts List

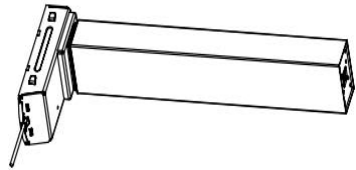

Column Leg
A (2 pcs)

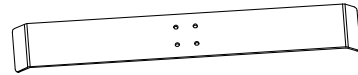

Feet
B (2 pcs)



Socket button head bolt
M6x35
C (8 pcs)

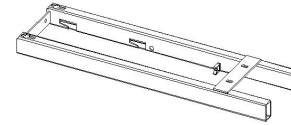

Crossbeam
D (2 pcs)



Connecting Beam
E (2 pcs)



Metal Screw
M10x16
F (8 pcs)

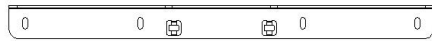

Longitudinal Beam
G (2 pcs)



Rubber
Washer
H (12 pcs)



Wood Screw
M4.8x19
I (14 pcs)

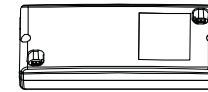

Control Box
J (1 pc)

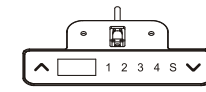

Display
K (1 pc)



Wood Screw
M3.5x15
L (2 pcs)

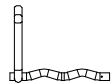

Pressure Retainer
Lever
M (2 pcs)



Pin
N (2 pcs)



R-Wire Clip
O (10 pcs)



Wood Screw
M3.5x16
P (10 pcs)



Wire Clip
Q (4 pcs)

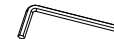

Hex Wrench
R (1 pc)

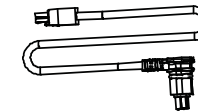

Control Wires
S (2 pcs)



Power Cord
T (1 pc)

Installation Steps

Step 1

Place worksurface finished side down on a blanket.

Step 2

Insert **G** longitudinal beams into **D** crossbeams assembly and slide forward to lock into place. Repeat on other side.

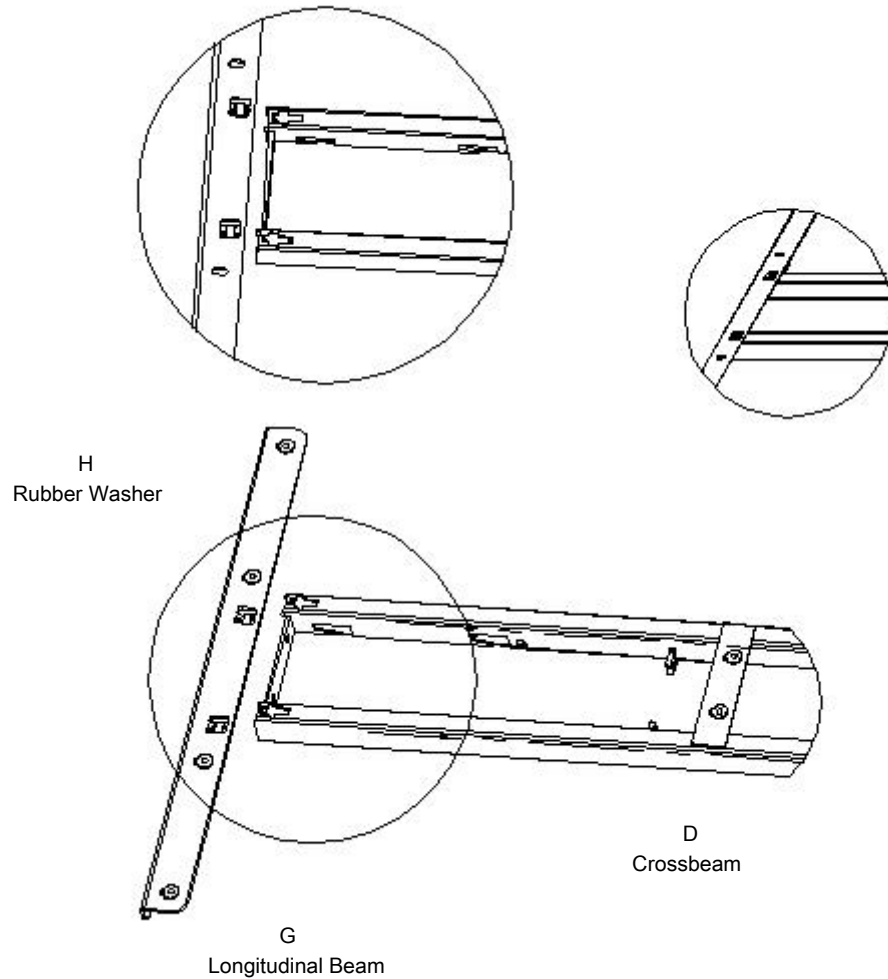

Step 3

Stretch **D** crossbeams to where you think it is, then use **I** (12) wood screws, 4.8×19 mm through **H** Rubber Washer to secure **G** Longitudinal Beams and **D** crossbeams to worksurface as shown. Repeat on other side.

Step 4

Use **F** (8) metal screws, M10×16 mm to secure **E** connecting beams as shown. .

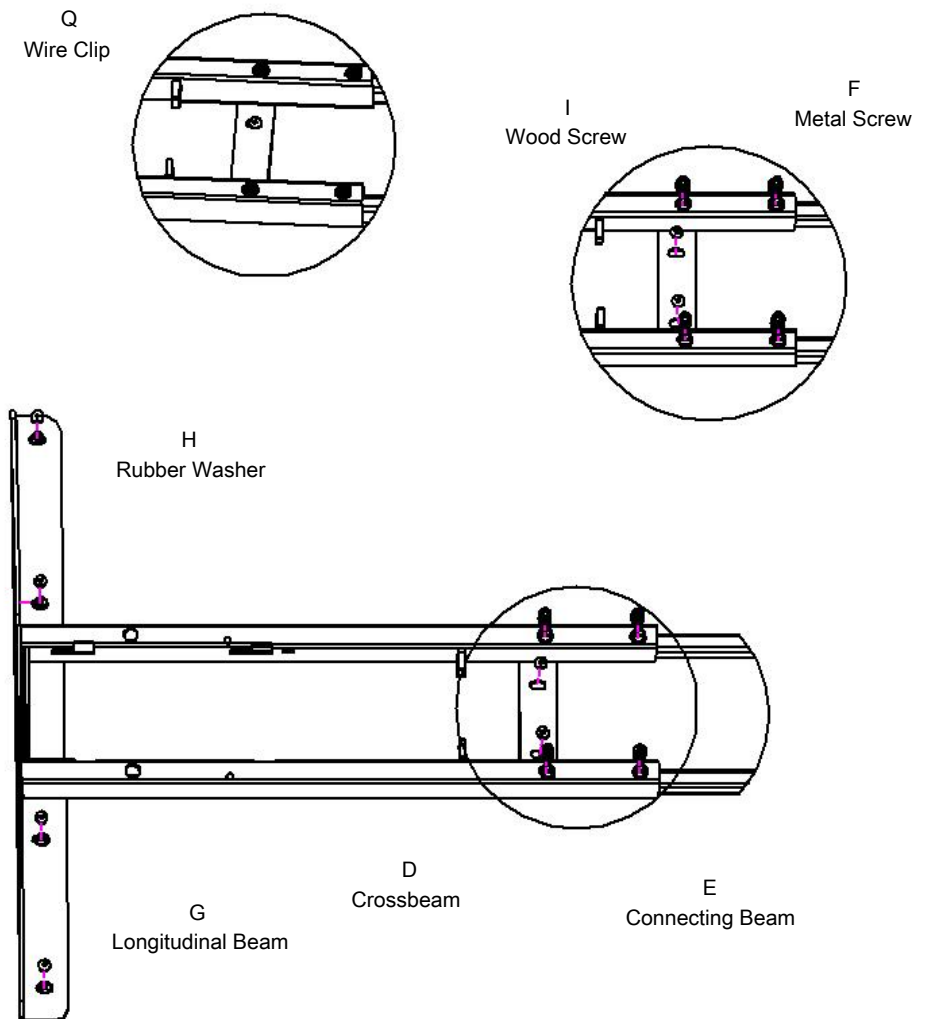

Step 5

Insert **A** column leg into **D** crossbeams assembly and slide back to lock into place. Repeat on other side.

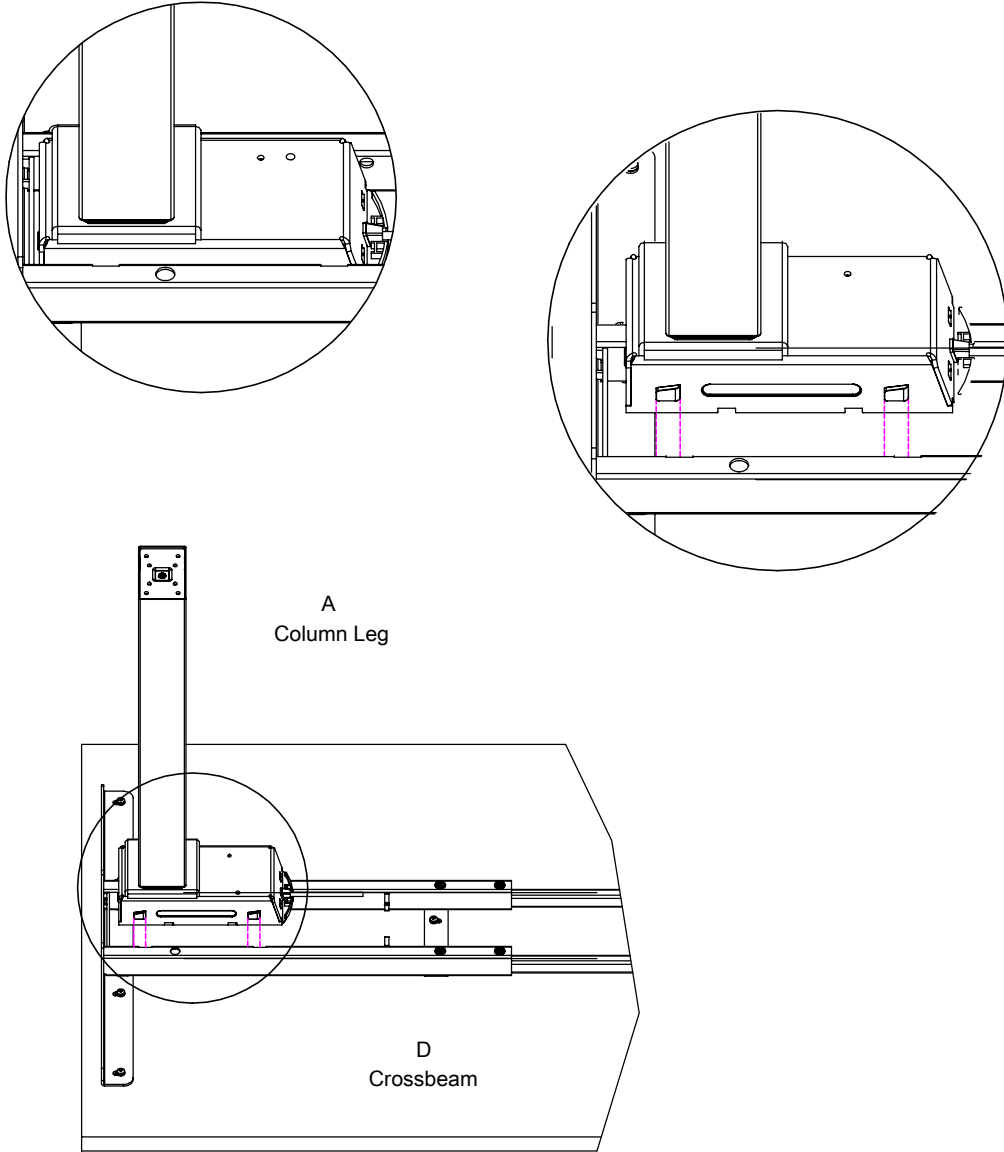

Step 6

Insert **M** Pressure Retainer Lever into **D** crossbeam and insert **N** pin into **M** Pressure Retainer Lever, then rotate the lever to clamp **A** leg. Repeat on other side.

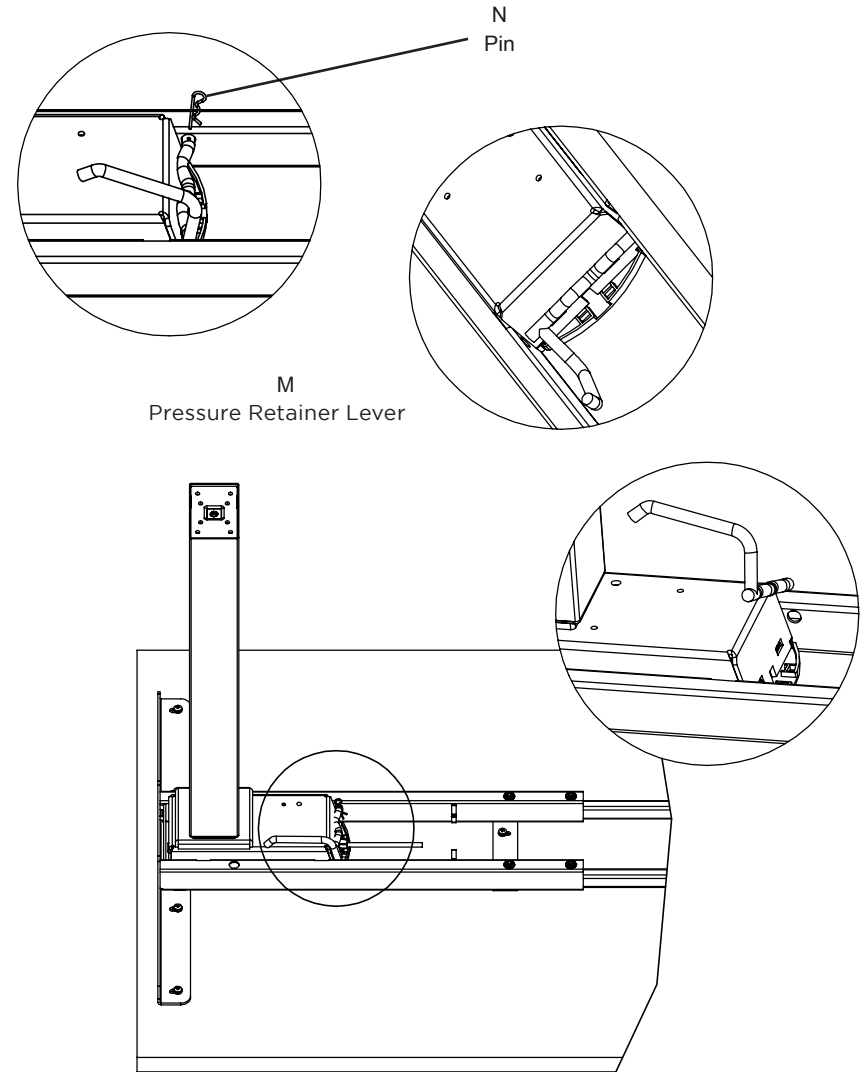

Step7

Secure **J** Control Box in the desired location with **I** (2) Wood Screw, M4.8×19.

Step8

Secure **K** Display in the desired location with **L** (2) Wood Screw, M3.5×15 with washers.

Step9

Use **Q** Wood Screw, M3.5×16 and **O** Sticky Card, or **Q**(4) Wire Clips to secure wires below the worksurface as shown.

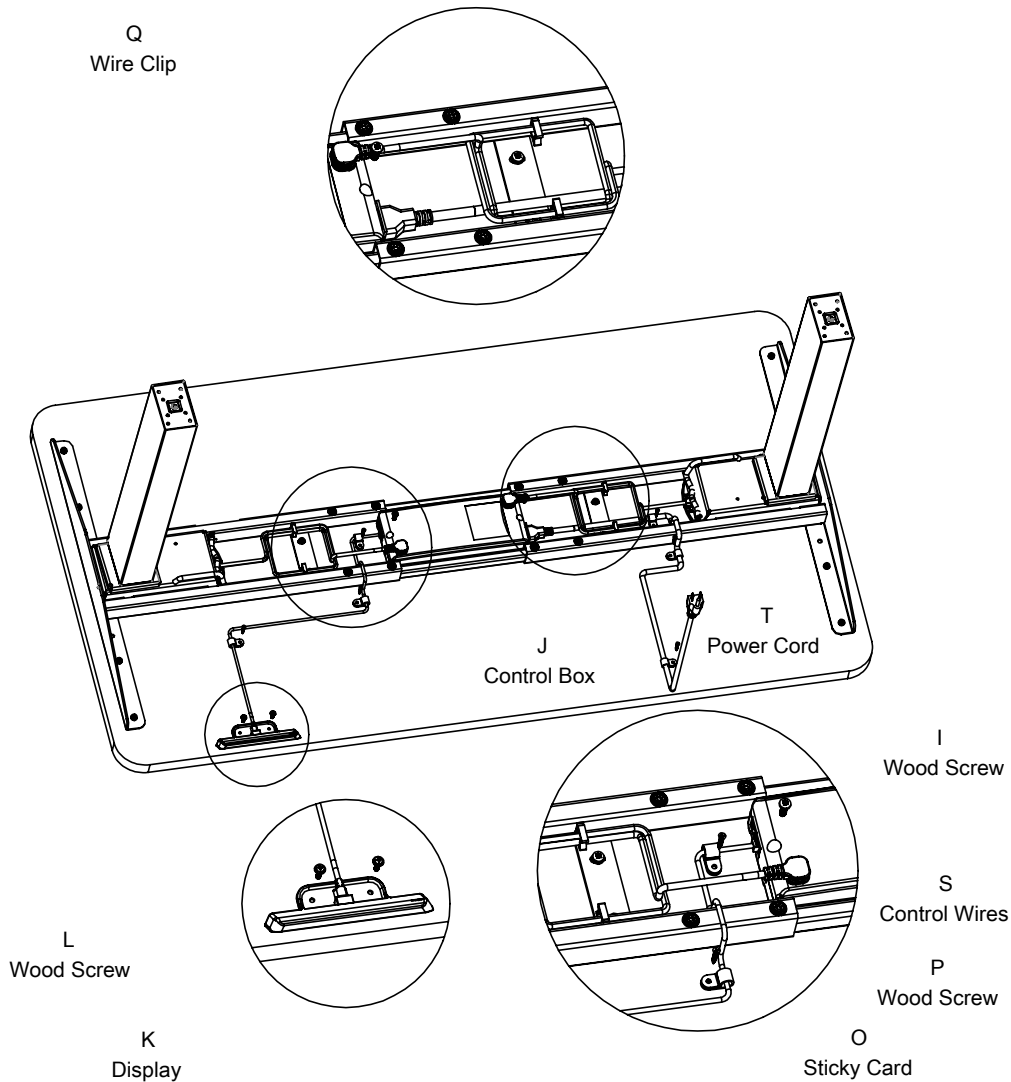

Step10

Attach **B** feet to **A** column leg with **C** (8) socket button head bolts, M65. Tighten bolts securely. Repeat on other side.

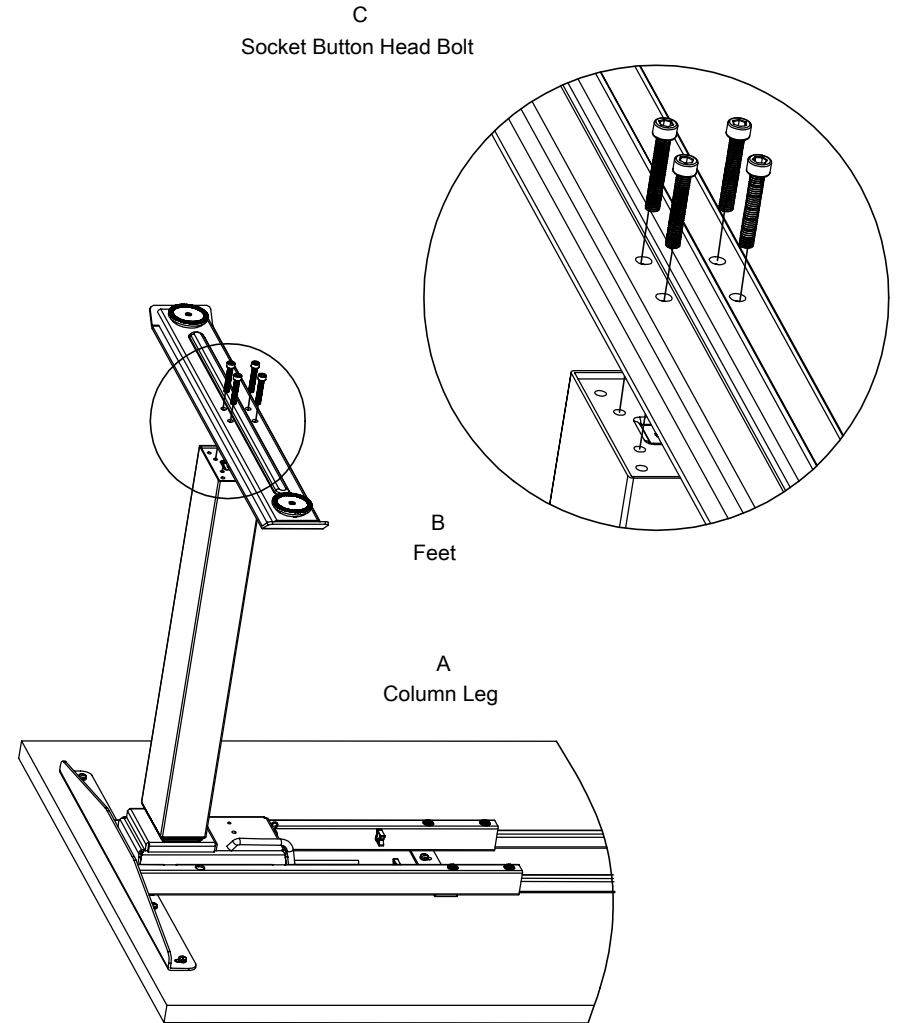

Schematic view of wiring

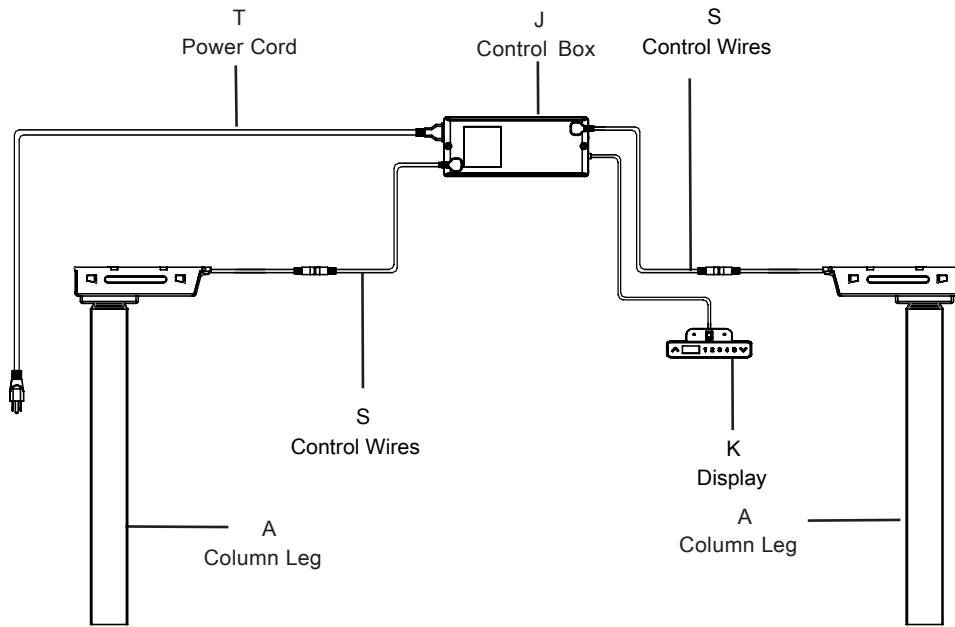

Step 11

Turn table right side up, adjust the glides as necessary, and plug the power cord into a 100-240v outlet. Make sure the length of the plug-in cord is appropriate to both reach the outlet, AND for the distance the table will travel up and down. Range: 28" at lowest to 45" highest.

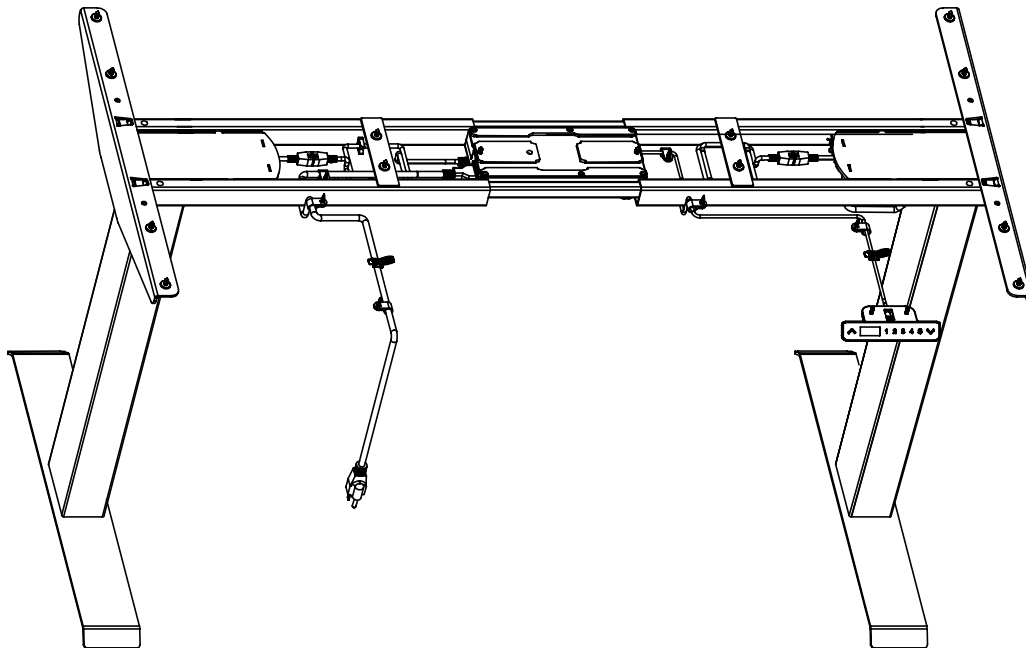
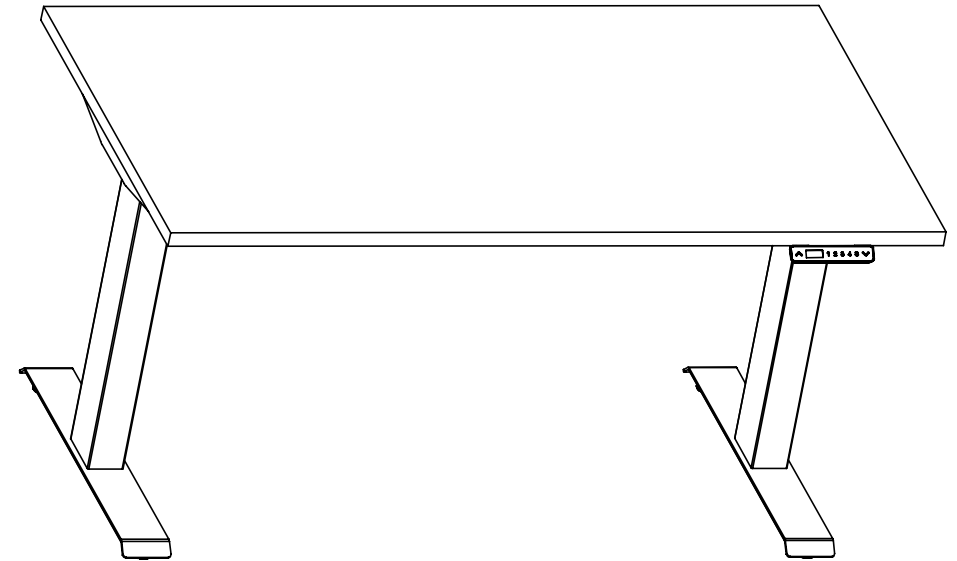

First Time Use:

Step 11

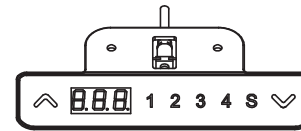

It is important to perform the reset procedure stated below before using your table for the first time.

1) Reset Operation

1. Press and hold \wedge & \vee simultaneously for more than 3 seconds till legs begin to move down at half speed of normal operation.
2. Keep pressing buttons till legs move down to the lowest position and rebound 2-5 mm, then stop.
3. Release together. Reset is completed

Notes:

- (a) The reset procedure must be completed after table is installed or parts replaced.
- (b) If reset process is interrupted, the system will stop running and will need to be reset to operate again.

2) Set Memory Position

1. Use **Λ** & **V** buttons to adjust the table.
2. Press **S**, then press button 1 or 2 or 3 or 4 within next 3 seconds to set height for that #. Display position 1,2,3,4 is saved.
3. After reset, memory settings need to be set again.

3) Removing Presets

1. Press and hold button **S** more than 10 seconds. Display will flash “— — —”
2. Release button **S**. Press button 1 within 3 seconds. The screen displays “H-0” which indicates that the presets are off. “H-1” indicates presets are on.
3. Press **Λ** or **V** to change the current function of turn on or off.
“H-0” - express function is off. “H-1” - express function is on.
4. Touch and hold button **S** for 2 seconds. Preset is on or off.

4) Set Maximum Height

1. Use **Λ** & **V** buttons adjust table to desired maximum height.
2. Press and hold **S**, then press and hold **3** for about 3 seconds. Release. Letter “**L**” flashes on the screen. This means the table will not go above this height.

5) Set Minimum Height

1. Use **Λ** & **V** buttons to adjust table to desired minimum height.
2. Press and hold **S**, then press and hold **1** for about 3 seconds. Release both buttons. Letter “**L**” flashes on the screen. This means the table will not go below this height.

6) Clear Minimum/Maximum Height

1. Press and hold **S**. Without releasing button **S**, press and hold **2** for 3 seconds.
2. Code “-C-” will clear.

7) Display in Inches or Centimeters

Press and hold **S**. Without releasing button **S**, press and hold **V** for 3 seconds. Release both buttons. The height information will toggle between inches and centimeters.

Troubleshooting 3 stage

Error Code	Explanation	Cause	Solution
E01	Connection Issue	The leg is disconnected from the control box.	Check the cable connections between leg and computer. Reset display. If problem persists contact our customer service.
E02	Continuous Operation	Continuous operation for 5 min.	Let motor rest for 10 min. Then try again. If problem persists contact Customer Service.
E03	Tabletop Overload	The tabletop load exceeds the weight limit.	Check that weight on table does not exceed weight limit . 3 stage straight -120kg, If problem persists contact Customer Service.
E04	Control Box Malfunction	Control Box Malfunction	Perform reset operation. If problem persists contact Customer Service.
E05	Display is frozen	Display locked for 30 seconds.	Perform reset operation. If problem persists contact Customer Service.
E06	Communication Disconnected	Connection lost between display and control box.	Check cables. Perform reset operation. If problem persists contact Customer Service.
E07	Display shows less than 0"	The height on display is lower than 0".	Perform reset operation. Set display height to 28" . If problem persists contact Customer Service.
E08	Motor Short Circuit	Motor cable damaged	Check the motor cable for damage. If problem persists contact Customer Service.
E09	Hall Error	Hall count error	Perform reset operation. If problem persists contact Customer Service.
E10	Actuator Error	Failure of control box actuator	Disconnect power supply for 1 minute then plug in. If problem persists contact Customer Service.
E11	Rebound Malfunction	Rebound function error	Perform reset operation. If problem persists contact Customer Service.
E12	Gyroscope abnormal	1. The gyroscope sensitivity sensor module is abnormal 2. Tilt the table	1. Restart the power. 2. Lay the desktop flat or place the control box flat. If problem persists contact Customer Service.

GENERAL TIPS

- Follow assembly instructions closely
- Do not overload the tables (120kg maximum straight)
- The input voltage should be within 100-240V
- Use the glides to properly level the table before use
- When moving the table, do not tilt the table on one leg or misalignment may occur
- Before first use, perform reset operation
- If after trouble shooting the problem persists, contact Customer Service for further assistance