

**OUTLAND**  
LIVING®  
FIRECUBE®

Owner's  
Manual

OUTDOOR LIVING PERFECTED®

From the Backyard to the Backwoods®

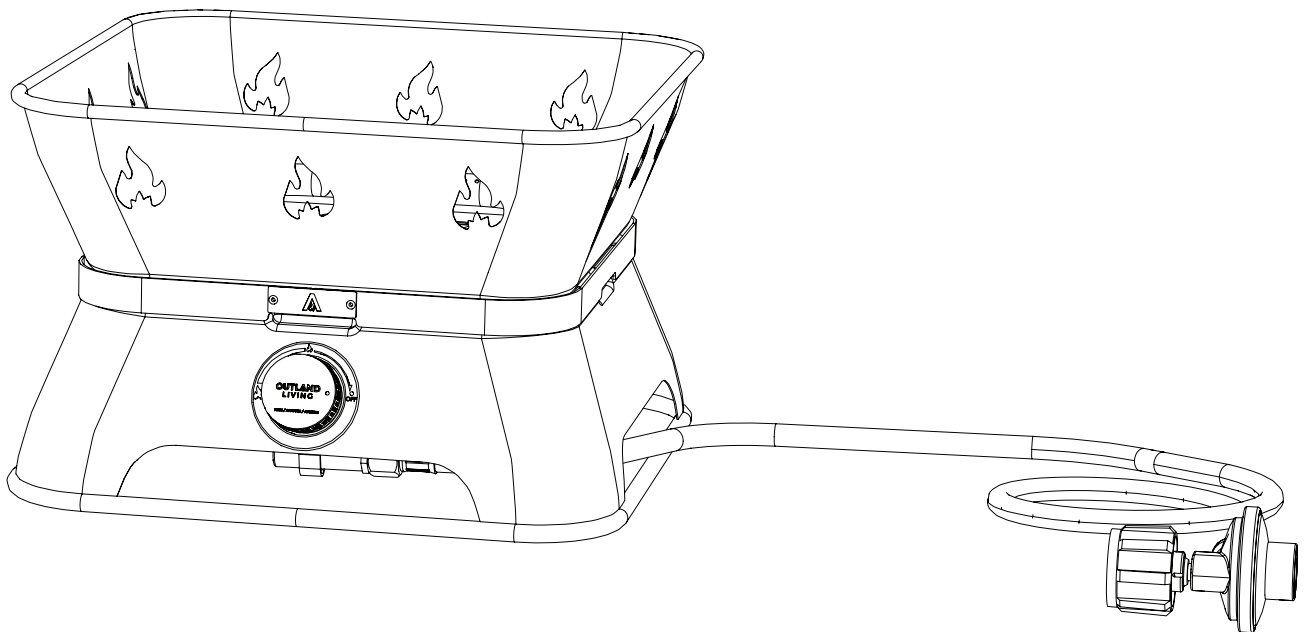

Model number FMPPC2H-805

® Registered trademark of FMI Brands Inc.  
The OUTLAND flame is a registered trademark of FMI Brands Inc.

58,000 Btu/h



MANUFACTURED BY FMI BRANDS INC. 107 – 19052 26 Avenue | Surrey, B.C. Canada V3Z 3V7  
USA, Canada Toll Free: 1-888-514-1663 | Tel: (+1) 778-294-0988 | Email: info@outlandliving.com  
Hours of Operation: 8:30AM - 4:00PM (Pacific Time) | Customer Service in English only

D.805.000.V0



Model number FMPPC2H-805 - Tested by CSA International  
ANS Z21.97-2017/CSA 2.41-2017 Outdoor Decorative Gas Appliances.

## **DANGER:**

If you smell gas:

- 1 Shut off gas to the appliance.
- 2 Extinguish any open flame.
- 3 If odor continues, leave the area immediately.
- 4 After leaving the area, call your gas supplier or fire department.

Failure to follow these instructions could result in fire or explosion, which could cause property damage, personal injury, or death.

## **WARNING:**

Do not store or use gasoline or other flammable vapors and liquids in the vicinity of this or any other appliance.

An LP-cylinder not connected for use shall not be stored in the vicinity of this or any other appliance.

## **WARNING:** For outdoor use only.

Installation and service must be performed by a qualified installer, service agency, or the gas supplier.

## **DANGER**



### CARBON MONOXIDE HAZARD

This appliance can produce carbon monoxide which has no odor.

Using it in an enclosed space can kill you.

Never use this appliance in an enclosed space such as a camper, tent, car, or home.





## **WARNING:**

If the information in this manual is not followed exactly, a fire or explosion may result causing property damage, personal injury or loss of life.

## **WARNING:**

Improper installation, adjustment, alteration, service or maintenance can cause injury or property damage. Read the installation, operating and maintenance instructions thoroughly before installing or servicing this equipment.

**INSTALLER:** Leave this manual with the appliance.

**CONSUMER:** Retain this manual for future reference.

## **GAS SAFETY:**

- Do not store a spare gas cylinder under or near this appliance.
- Never fill the cylinder beyond 80 percent full.
- If the information in "(a)" and "(b)" is not followed exactly, a fire causing death or serious injury may occur.

Do not use this appliance under overhead combustible surfaces.

### **MINIMUM CLEARANCES:**

- Bottom:** Non-Combustible Surface
- Top:** 2 m / 80 in
- Sides:** 0.9 m / 36 in
- For Installation on (or over) non-combustible floors only.

**Input:** 58,000 Btu/h (17 kW) and manifold pressure:  
11 in wc (2.74 kPa)

**Min. gas supply for input adj.:** 11 in wc (2.74 kPa)

**Max. gas supply:** 11 in wc (2.74 kPa)

**Injector Size\*** 2.35mm

\* Injector size marked clearly on the gas valve orifice.

**Type of Gas:** Propane (LP)

This appliance shall be used only outdoors in a well-ventilated space and shall not be used in a building, garage or any other enclosed area.

The gas supply must be turned off at the LP-gas supply cylinder when this appliance is not in use.

Indoor storage of this appliance is permissible only if the cylinder is disconnected and removed from the appliance.

Cylinders must be stored outdoors in a well-ventilated area out of the reach of children.

Disconnected cylinders must have threaded valve plugs tightly installed and must not be stored in a building, garage or any other enclosed area.

The gas pressure regulator provided with this appliance must be used, and must be the same model as supplied with the unit.

The cylinder supply system must be arranged for vapor withdrawal.

Cylinders used with this unit must have a collar to protect the cylinder valve.

An approved LP-Cylinder stabilizer, such as the stabilizer ring included, must be used when the appliance is in use.

Replacement parts and a list of such parts are available from FMI Brands Inc. through the contact information provided on the last page of this Manual.

## **WARNING:**

Please ensure that all adults and children which use or are near a unit in use are aware of the hazard of high-surface temperatures present on the unit during use and should use caution and stay away to avoid burns or clothing ignition.

Carefully supervise young children in the area of this appliance. Clothing or other flammable materials should not be hung from the appliance or placed on or near the appliance. Any guard or other protective device removed for servicing the appliance must be replaced prior to operating the appliance.

Installation and repair should be done by a qualified service person. The appliance should be inspected before use and at least annually by a qualified service person. More frequent cleaning may be required as necessary. It is imperative that control compartment, burners and circulating air passageways of the appliance be kept clean.

All LP cylinders to be used with this appliance must be:

- Constructed and marked in accordance with the U.S. Department of Transportation (DOT) *Specifications for LP-Gas Cylinders*, or the *Standard for Cylinders, Spheres and Tubes for Transportation of Dangerous Goods*, CAN/CSA B339, as applicable.
- Provided with a listed overfilling prevention device.
- Provided with a cylinder connection device compatible with the connection for the appliance.
- Only a 9 kg / 20 lb LP gas cylinder is to be used for this appliance, approximately 46 cm / 18 in" high & 30 cm / 12 in" diameter.
- The use of an approved LP gas cylinder stabilizer, such as the one included, must be used when using this appliance in order to prevent the LP gas cylinder from tipping over.

## CONNECTION:

1. Be sure the cylinder valve and appliance valves are "off".
2. Place full LP gas cylinder on tank stabilizer ring.
3. Center the nipple in the cylinder valve and hold in place.
4. Using the other hand, turn the hand wheel clockwise until there is a positive stop. Do not use tools.
5. **Hand tighten only. When making the connection, hold the regulator in a straight line with the cylinder valve, so as not to cross thread the connection.**
6. Leak test the connection. See section named "LEAK TEST".

## LEAK TEST:

1. DO NOT USE OR PERMIT SOURCES OF IGNITION IN THE AREA WHILE DOING THE LEAK TEST. THIS INCLUDES SMOKING.
2. Leak testing should be done once per year or whenever the LP gas cylinder or any other gas system part is taken apart, serviced or replaced, whichever is more frequent.
3. Ensure all gas system coupling joints are tight and properly attached.
4. Prepare a leak testing solution of half liquid detergent and half water.
5. Apply the solution to the LP gas delivery system at points as shown in illustration indicated to the right.
6. If parts of the fitting begin to produce bubbles, spray liquid, or if you smell liquid propane gas, immediately close the valve on the tank.
7. Wait 5 minutes for any gas to dissipate.
8. After waiting for 5 minutes, the leak(s) must be stopped by tightening the loose joints, if possible, or by replacing the faulty part(s) with the part(s) recommended by the appliance manufacturer.

## **WARNING:**

Ensure that the appliance is kept at a minimum distance of 0.91 m / 36 in from the gas cylinder.

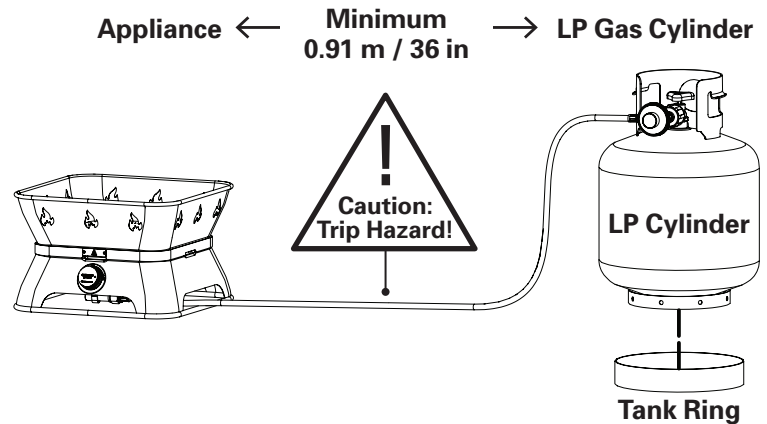

**LEAK TEST:** Apply the solution to the LP gas delivery system at points:

1. OUTLAND Firecube Valve Coupling
2. Gas Hose Regulator
3. Cylinder Valve Coupling

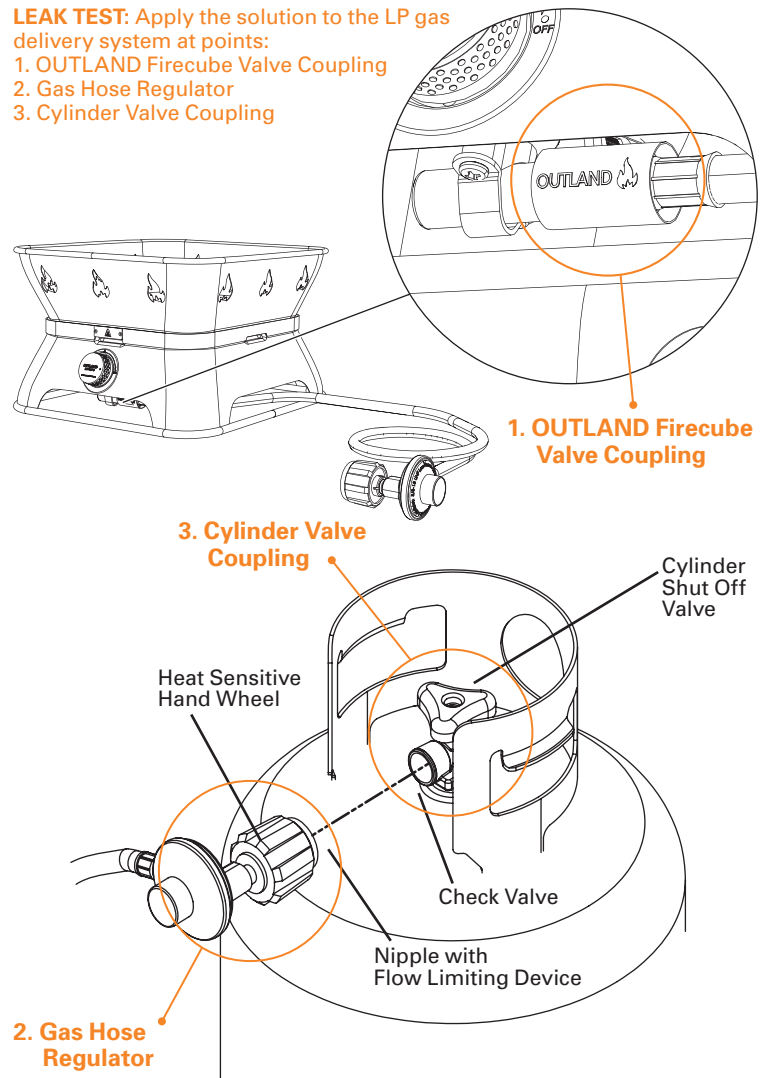



## THE APPLIANCE IS NOT TO BE USED UNTIL ANY LEAK IS CORRECTED.

A gas appliance repairman or LP gas dealer should be called if attempts to stop the leak(s) are unsuccessful and, in such case, the LP gas supply must be shut off at the cylinder valve or the cylinder must be removed from the appliance until the leak(s) is corrected.

Should any part of this appliance (including the burner) become soiled or dirty, wipe lightly with a damp cloth. Do not use flammable or corrosive cleaning products on or near this unit.

Ensure that gas hose is placed in an area where it is unlikely to be tripped over (such as pathways or trails) or subject to other accidental damage.

Keep the appliance area clear and free from combustible materials, gasoline and other flammable vapors and liquids.

Solid fuels shall not be burned in this appliance.

Installation must conform with local codes or, in the absence of local codes, with either the *National Fuel Gas Code, ANSI Z223.1/ NFPA 54, Natural Gas and Propane Installation Code, CSA B149.1* or *Propane Storage and Handling Code, B149.2*, or the *Standard for Recreational Vehicles, ANSI A 119.2/NFPA 1192, and CSA Z240 RV Series, Recreational Vehicle Code*, as applicable.

## PRE-IGNITION INSPECTIONS

### GAS HOSE INSPECTION

Clean and inspect the hose before each use of the appliance.

**Attention:** If there is evidence of abrasion, wear, cuts, or leaks, the hose must be replaced prior to the appliance being put into operation. Only use a replacement hose by OUTLAND Living.

### BURNER & ORIFICE INSPECTION

Inspect the burner prior to each use. Ensure the orifice holes are not plugged and the burner tube is not damaged, or compromised.

The burner must be replaced prior to the appliance being put into operation if there is evidence of damage. Replacement burners are available from FMI Brands Inc.

### BURNER TUBE INSPECTION

Inspect the burner tube under the appliance and ensure the mesh screen is in place, prior to each use.

**ATTENTION:** If the screen is dislodged perform an insect nest inspection, prior to ignition. See section 'REMOVING INSECT NESTS'.

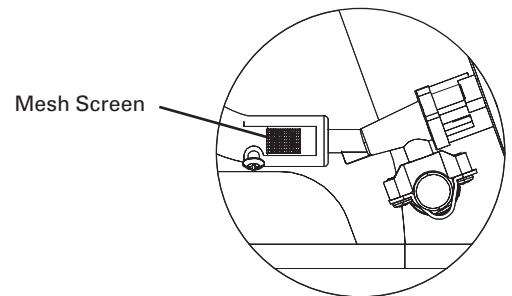

## SECTION 1: ASSEMBLY

Enclosed are four bags of rocks, one factory installed 3 m / 10 ft propane-rated hose with attached regulator, one propane tank stabilizer ring, one lid and one carry strap.

**STEP 1** Open the three bags of rocks and arrange the rocks in burner area. Select larger sized rocks and arrange on top of the mid-sized rocks.

**Our preferred configuration is pictured here.**

Never handle rocks which have not been allowed to cool from exposure to flame. Never attempt to rearrange rocks while unit is ignited.



Rocks are of natural and varying sizes. Model may not look exactly as shown.

**STEP 2** The fourth bag of rocks are included as spares and labelled "Spare Rocks". These can be stored and used as replacements.

### Note:

- Rocks are not to exceed a maximum weight of 2.5 kg / 5.5 lb.
- Never use a lid to extinguish the flame on your OUTLAND Firecube®.
- The lid and carry straps (Cover & Carry Kit) is to be used for storage and transportation only.

### NOTE TO USER:

Before igniting the unit for the first time, follow steps 1 through 5 in the below Ignition section.

## WARNING:

Never use the lid to cover your OUTLAND Firecube while the burner is in operation. After use, allow the OUTLAND Firecube to cool for at least 10 minutes prior to deploying the lid and carry strap.

## COVER & CARRY KIT INSTALLATION

Your included Cover & Carry kit is to be used for storage and transportation as shown.

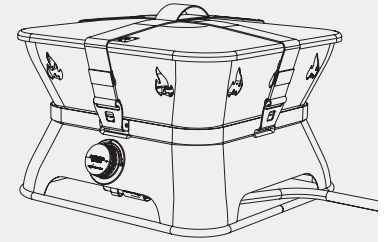

The carry straps are designed to hook onto the bottom of the Outland Living Firecube's waistband. Please note the carry straps fit snug but will stretch enough to ensure the perfect fit.

## SECTION 2: IGNITION

### STEP 1

Ensure that the appliance valve dial is in the "OFF" position by pushing and turning clockwise until the dial stops.



### STEP 2

Securely attach regulator (large end of hose) to your propane cylinder.



### STEP 3

Extend hose to full length and ensure that the propane tank is as far as safely possible from the OUTLAND Firecube and place the tank in the included stabilizer ring.

Appliance ← Minimum 0.91 m / 36 in → LP Gas Cylinder

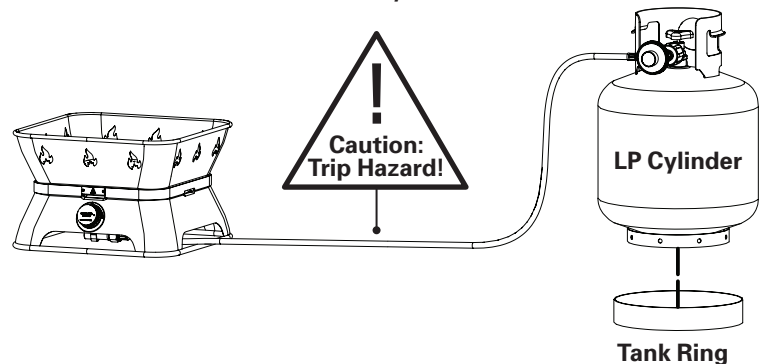



## SECTION 2: IGNITION (continued)

### **WARNING:**

TRIP HAZARD! Ensure the gas hose is placed in an area where it is unlikely to be tripped over (such as pathways or trails) or subject to other accidental damage.

### **WARNING:**

The hose should not be twisted or kinked when attached to the gas cylinder. The hose should never touch the appliance. Ensure that the appliance is kept at a minimum distance of 0.91m (36") from the gas cylinder.

#### STEP 4

**\*\*\*SLOWLY\*\*\*** turn cylinder valve to the **FULLY** open position to avoid tripping the excess flow safety device in the gas regulator. For more information about the excess flow safety device see STEP 8.

#### STEP 5

Leak Test all connections. See section labeled "Leak Test" (page 3).

#### STEP 6

Using a lighter or match, ignite lighter and hold flame slightly above the burner, then open the valve on the appliance slowly by turning (counter-clockwise) until the unit ignites.

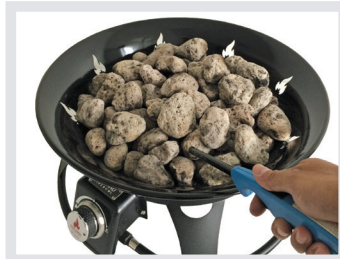

Model may not look exactly as shown

### **WARNING:**

Ensure that no parts of your body, clothing, or any other combustible material are above the burner before, during and after ignition.

#### STEP 7

Once the unit is burning normally set the dial to desired flame height.



Model may not look exactly as shown

#### STEP 8: TROUBLESHOOTING

**GOT A LOW FLAME?:** If your OUTLAND Firecube experiences low flame, or flame height does not appear to be normally adjusted by the gas knob, it is likely that the gas cylinder is low in fuel, or the excess flow safety device has been tripped in the gas regulator.

**NOTE:** Elevation and temperature affect the cylinder gas pressure and performance (flame height) of gas appliances. Your geographic location or local weather may be at fault.

#### **CORRECTIVE ACTION:**

- Confirm your gas cylinder is NOT empty.
- Close the propane cylinder valve.
- Open and then close the appliance gas knob valve to release pressure.
- Be sure the appliance valve is OFF.
- Disconnect the gas hose from the propane cylinder.
- Gently tap the gas regulator housing on the ground once or twice.
- Reconnect the gas hose to the propane cylinder.
- Slowly and fully open the propane cylinder valve.
- Perform a Leak Test and follow the Ignition sequence.

**TIP:** Try tapping the regulator on the ground or hard surface 3 times. Sometimes, this will reset the safety device in the regulator.

#### **WHAT IS AN EXCESS FLOW SAFETY VALVE? (EFV)**

The EFV is a safety mechanism contained within the gas regulator. The purpose of the EFV is to restrict the gas supply if too much gas is flowing too quickly through the gas hose. For example this could happen if the gas hose was severed. It is normal that your Fire Bowl EFV trips if you open the propane tank valve too quickly or if you leave the OUTLAND Firecube gas knob open before lighting, or both.

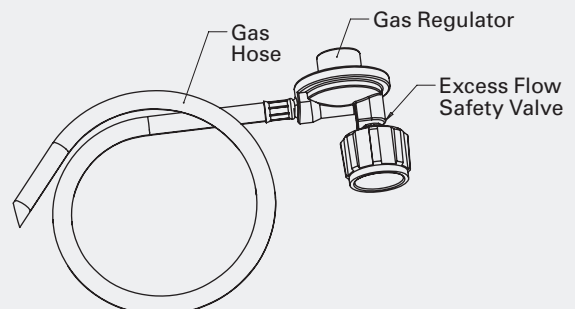

## SECTION 3: PERIODIC INSPECTION OF BURNER FLAMES



Model may not look exactly as shown

Upon igniting the appliance, visually verify that the burner is indeed burning as demonstrated in the image to the left. The presence of flames will confirm that the burner is burning. Periodically check that the burner flame is present during operation by visually inspecting the burner to ensure the presence of flames.



Model may not look exactly as shown

If there are no flames present, as demonstrated in the image to the left, the appliance is likely not burning. If this is the case, IMMEDIATELY turn the appliance valve to the "off" position if it is not already and repeat the ignition procedure as outlined in Section 2.

## SECTION 4: EXTINGUISHING THE APPLIANCE

### STEP 1

Turn cylinder valve to the "closed" position.

### STEP 2

Turn appliance valve to the "OFF" position by pushing and turning knob clockwise.

### STEP 3

Allow unit to cool for at least five (5) minutes before relighting.

**! WARNING:**  
**The rocks are HOT!**

**! WARNING:**

Don't burn yourself! Do not touch or handle the appliance when hot! To avoid injury always allow the OUTLAND Firecube to cool down for at least 30 minutes before moving and handling the appliance. Never handle rocks which have not been allowed to cool from exposure to flame. Never attempt to rearrange rocks while unit is ignited.

## SECTION 5: APPLIANCE MAINTENANCE

### REGULAR CLEANING & MAINTENANCE

Your OUTLAND Firecube requires periodic maintenance to keep it in good running order.

Follow the steps below to ensure your appliance will provide you with the best possible performance:

- 1 Keep your Firecube out of the rain and store it in a dry place when not in use.
- 2 Ensure to keep the lid on when storing your Outland Firecube. The lid is designed to keep leaves and debris out of the firecube. The lid is not designed to protect from rain and rust. Your firecube and lid are made from steel and will naturally form rust if left out in the rain for extended lengths of time.
- 3 Always inspect and clear all valve and gas orifices of any foreign debris including spider webs prior to lighting. If any doubt there may be a nest inside, use a pipe cleaner up the tube. See section 'REMOVING INSECT NESTS'.
- 4 Clean any plugged burner orifices with a small paper clip.
- 5 Ensure that you clean the bowl of your Outland Firecube after every use to keep it looking GREAT. Simply wipe the outer edge of the Firecube with a damp paper towel or cloth to remove any combustion particulates. Do not use flammable or corrosive cleaning products on or near this unit.





## SECTION 5: FIREBOWL MAINTENANCE (continued)

### LAVA ROCKS

Your non-toxic natural lava rocks will form cracks and turn brown and black under normal operating conditions. This does not affect the functionality of your firebowl.

The image shown is a visual reference on what the lava rocks will look like over time while under normal operating conditions.



*Model may not look exactly as shown*

### WARNING NOTES:

- Expected burn time: The anticipated burn time for your OUTLAND Firecube using a full 9 kg / 20 lb propane cylinder is between 7 and 11 hours, depending on flame height setting and complete cylinder fill.
- FMI Brands Inc. recommends that you ignite this unit only when safely placed on a non-combustible surface.
- Never use this appliance in tall grass
- This is NOT a toy.
- Children should be supervised at all times when using this unit without exception.
- Please ensure that all adults and children which use or are near a unit in use are aware of the hazard of high-surface temperatures present on the unit during use and should use caution and stay away to avoid burns or clothing ignition.
- Do not place any objects other than supplied rocks inside the burner component of the OUTLAND Firecube.
- Do not add wood or any other materials to the fire. It is designed to safely combust gas only.
- Do not connect to a remote gas supply.
- Do not use this appliance if any part has been under water. Immediately call a qualified service technician to inspect the appliance and to replace any part of the control system and any gas control which has been under water.
- Do not leave this appliance in the rain.
- Always inspect and clear all valve and gas orifices of any foreign debris including spider webs prior to lighting.
- This device has been engineered to provide the maximum amount of heat and comfort. If you experience any signs of your propane cylinder 'freezing off' or start to experience lower flames than usual, please simply turn the burner control setting to low for 5–10 minutes, or replace the cylinder with a full one.
- Elevation and temperature affect the performance (flame height) of gas appliances.

## REMOVING INSECT NESTS

### **WARNING:**

Small critters like spiders and earwigs can quickly build nests inside the burner tube which can obstruct gas flow and impact the flame height and heat performance of your appliance. More seriously, a nest or blockage of the burner tube can cause a back flame event, damage to your appliance, or even extreme operator injuries!

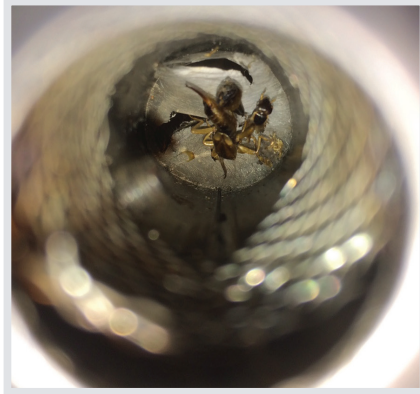

Clean the burner tubes often and especially if the appliance has been sitting unused for a period of time. You must remove the gas valve to gain access to the burner tube for cleaning.

### **BURNER TUBE CLEANING INSTRUCTIONS:**

#### **STEP 1**

Ensure the appliance valve(s) are OFF and the cylinder valve is closed.

#### **STEP 2**

Disconnect LP Cylinder.

#### **STEP 3**

Remove the lava rocks and set them aside.

#### **STEP 4**

Locate and remove the heatshield nuts underneath the Firecube. Carefully set these nuts aside.

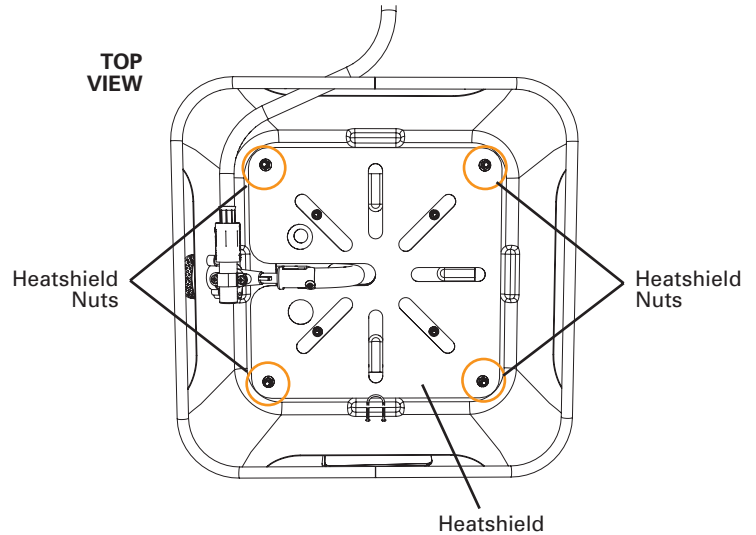

#### **STEP 5**

Carefully remove and set aside the heatshield.

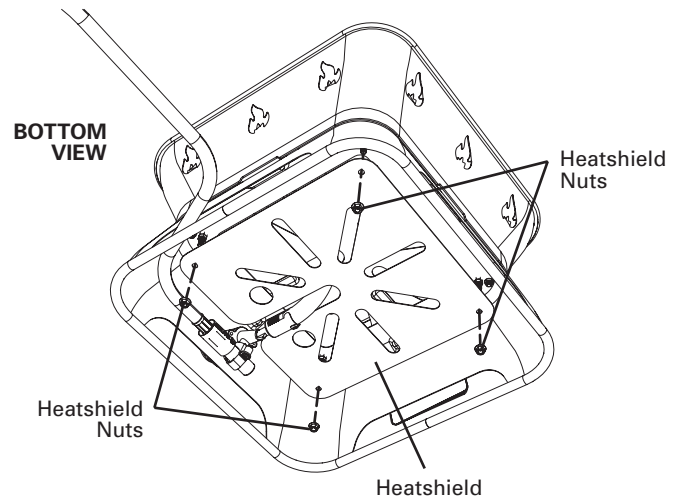



### STEP 6

Locate and remove the mounting screws and nuts of the burner tube. Carefully set the mounting screws and nuts aside.

### STEP 7

Carefully remove the burner tube.

### STEP 8

Use a flashlight to look inside the burner tube. Use a long flexible pipe cleaner, or long small utensil to clean out any debris or nest material. An air tool to blow out the burner is helpful, but please wear eye protection.

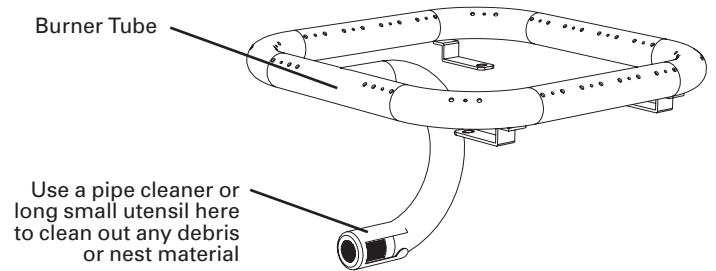
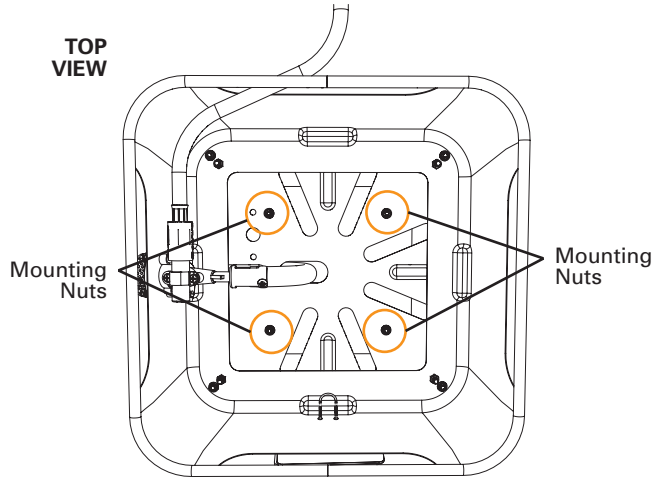

### STEP 9

When the burner tube is determined to be clear, install the burner. Install the mounting screws and nuts.

### STEP 10

Install the heat shield. Install the heatshield nuts.

### STEP 11

Insert the lava rocks in the burner area.

### STEP 12

Connect the LP Cylinder.

**IMPORTANT: Align gas valve orifice inside burner tube.**

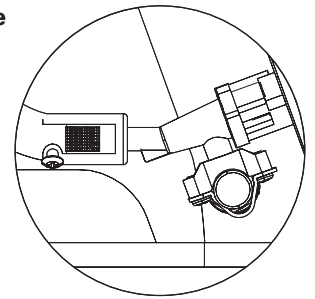
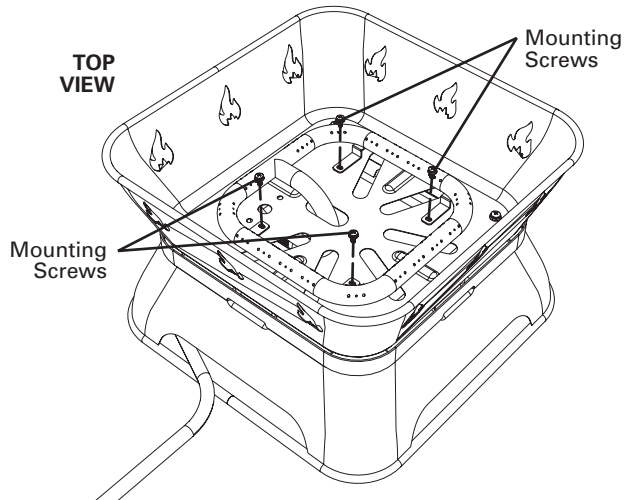
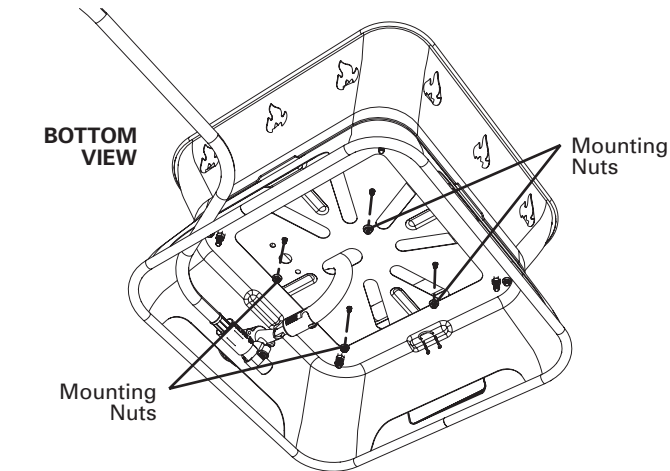

### **WARNING:**

The gas valve orifice should be inside the burner tube and visible through the bug screen mesh. If your orifice and burner tube does not line up like in the image above, please call customer service at (888) 514-1663 or E-Mail to [info@outlandliving.com](mailto:info@outlandliving.com).

## 1 YEAR LIMITED WARRANTY Customers in Canada & USA

All components are warranted by the manufacturer for a period of 1 year after date of purchase by the original owner against defects in materials and workmanship under normal use.

This warranty does NOT cover normal wear and weathering, assembly and/or maintenance OR use in a commercial application. At FMI Brands Inc.' sole discretion, products under warranty will be repaired and/or replaced at no charge to the customer.

Any returns sent back to FMI Brands Inc. must be sent via prepaid freight and in the original retail packaging.

**Please register your OUTLAND Living product for proof of purchase and warranty at:**

<http://outlandliving.com/register-products/>.

Registration in English only.

For more warranty information and details please contact Customer Service at [info@outlandliving.com](mailto:info@outlandliving.com).



**If you experience ANY problems with your OUTLAND Firecube, PLEASE DO NOT RETURN IT TO YOUR POINT OF PURCHASE!**

Simply call us or send an email to [info@outlandliving.com](mailto:info@outlandliving.com) and we will answer all questions and/or concerns that you may have.

We take pride in our products at FMI Brands Inc. (Outland Living) and will strive to provide excellent customer support.

### **FMI BRANDS INC.**

107 – 19052 26 Avenue, Surrey, BC Canada V3Z 3V7

USA, Canada Toll Free: 1-888-514-1663

Tel: (+1) 778-294-0988 • Email: [info@outlandliving.com](mailto:info@outlandliving.com)

Hours of Operation: 8:30AM - 4:00PM (Pacific Time)

Customer Service in English only

**FOR REPLACEMENT PARTS AND ACCESSORIES PLEASE VISIT  
[WWW.OUTLANDLIVING.COM](http://WWW.OUTLANDLIVING.COM)**

The owner's manual is available as a free download from [www.outlandliving.com](http://www.outlandliving.com)

Should you have any questions or comments regarding this appliance, please do not hesitate to contact FMI Brands Inc. at **1-888-514-1663** or E-Mail to [info@outlandliving.com](mailto:info@outlandliving.com).