

Overview Description

The Hero VTOL is a multi-purpose vertical take-off and landing fixed wing. The unique design of the UAV nose can be replaced, which can be equipped with an orthophoto camera or a tilt camera when used in the field of surveying and mapping, and can be equipped with an optoelectronic pod in the field of monitoring. The multi-purpose design expands the range of applications and reduces the cost of flight.

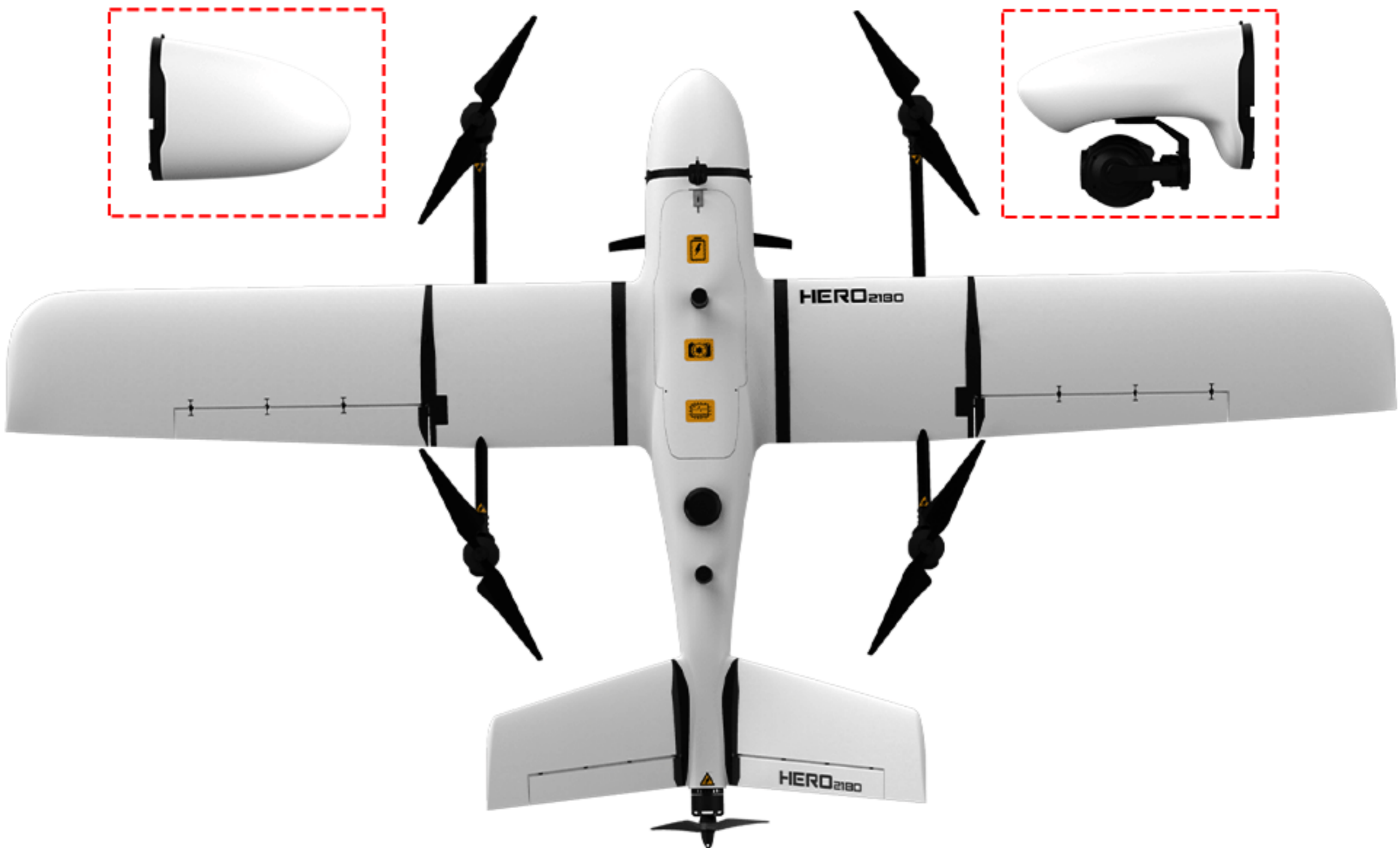

Basic Parameters

Wingspan: 2180mm

Wing area: 53dm²

Cruising speed: 17-22m/s

Aircraft angle of attack: 0-2°

Stall airspeed: 12m/s

Maximum climb angle: 3.5°

Maximum roll angle: 30°

Take-off weight: <7kg

Ceiling altitude: 6500m

V tail angle: 28° up, 20° down

Working temperature: -10°C-50°C

Packing box size: 1100*350*430mm

Take-off and landing method: vertical take-off and landing

Material: EPO, carbon fiber, aviation aluminum alloy, engineering plastic, etc.

Mapping endurance: 136min/144km (speed 19m/s, load 600g,

Battery 6S@22000mah, take-off weight 6.65kg)

Monitoring endurance: 125min/126km (speed 18m/s, load 450g,

Battery 6S@22000mah, take-off weight 6.5kg)

Vertical arm: 755mm (including motor base)

Body height: 255mm (including tripod)

Body length: 1140mm

Wing Mounting Angle: 2.9°

Conversion airspeed: 14m/s

Maximum dive angle: 5°

Payload: <1kg

Take-off altitude: <3000m

Wind resistance: level 5 (normal operation)

Disassembly method: quick disassembly without tools

Aileron Rotation: Up 22° Down 28°

Efficient Aerodynamics

The Hero VTOL adopts a high-efficiency V-shaped tail, and at the same time optimizes the aerodynamic shape and relative position of the wing, tail and fuselage. The aerodynamic load distribution is reasonable, the lift and drag are significantly increased, and the flight efficiency is high.

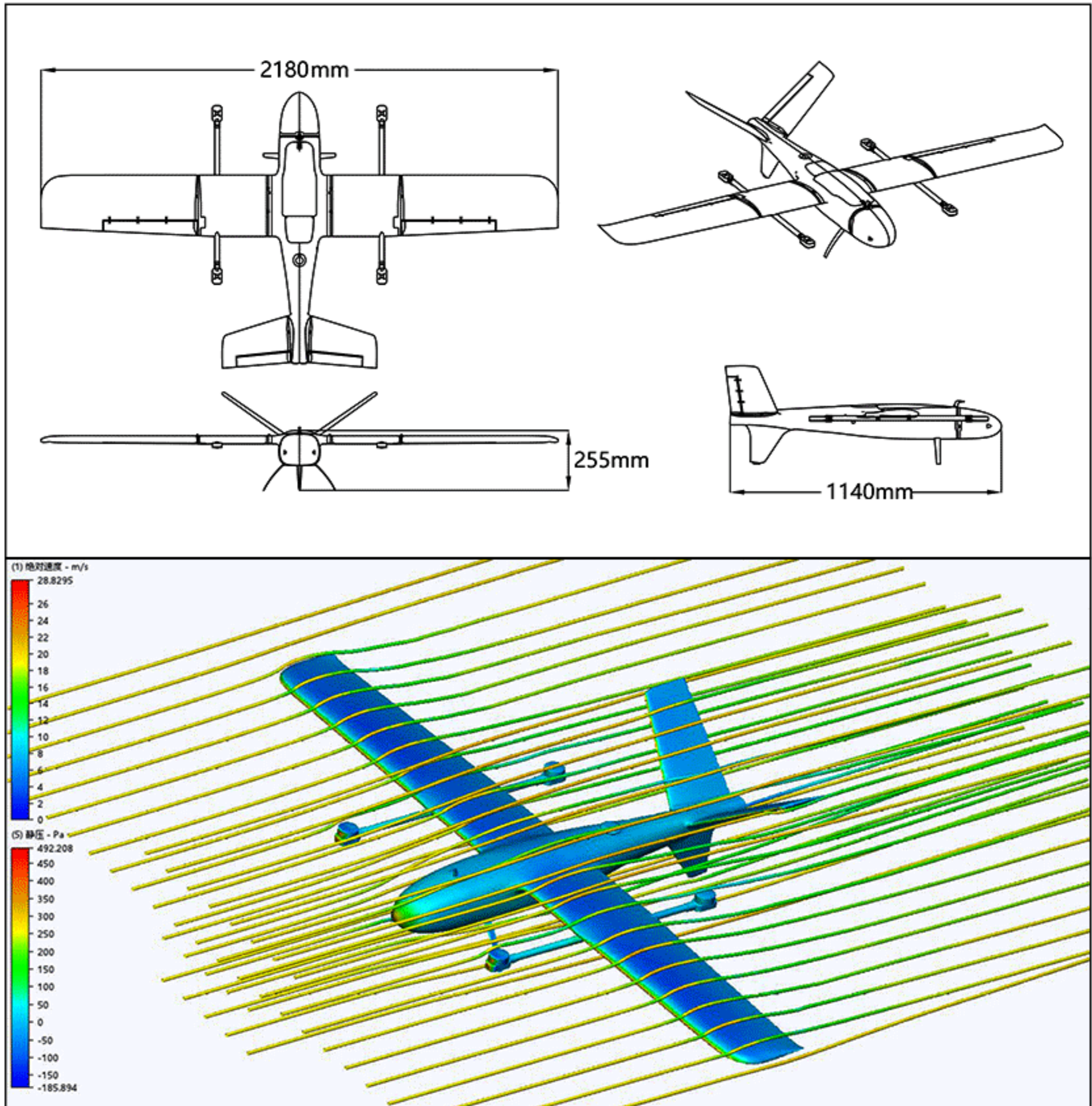

The Hero VTOL adopts a streamlined shape as a whole to reduce flight resistance as much as possible while ensuring stable flight.

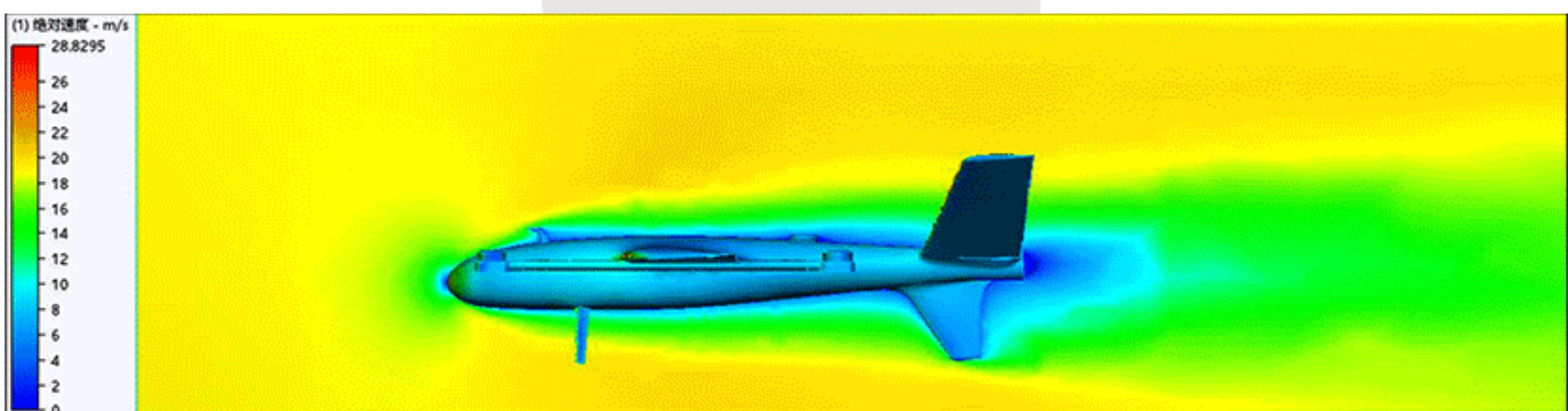

Light but Stable

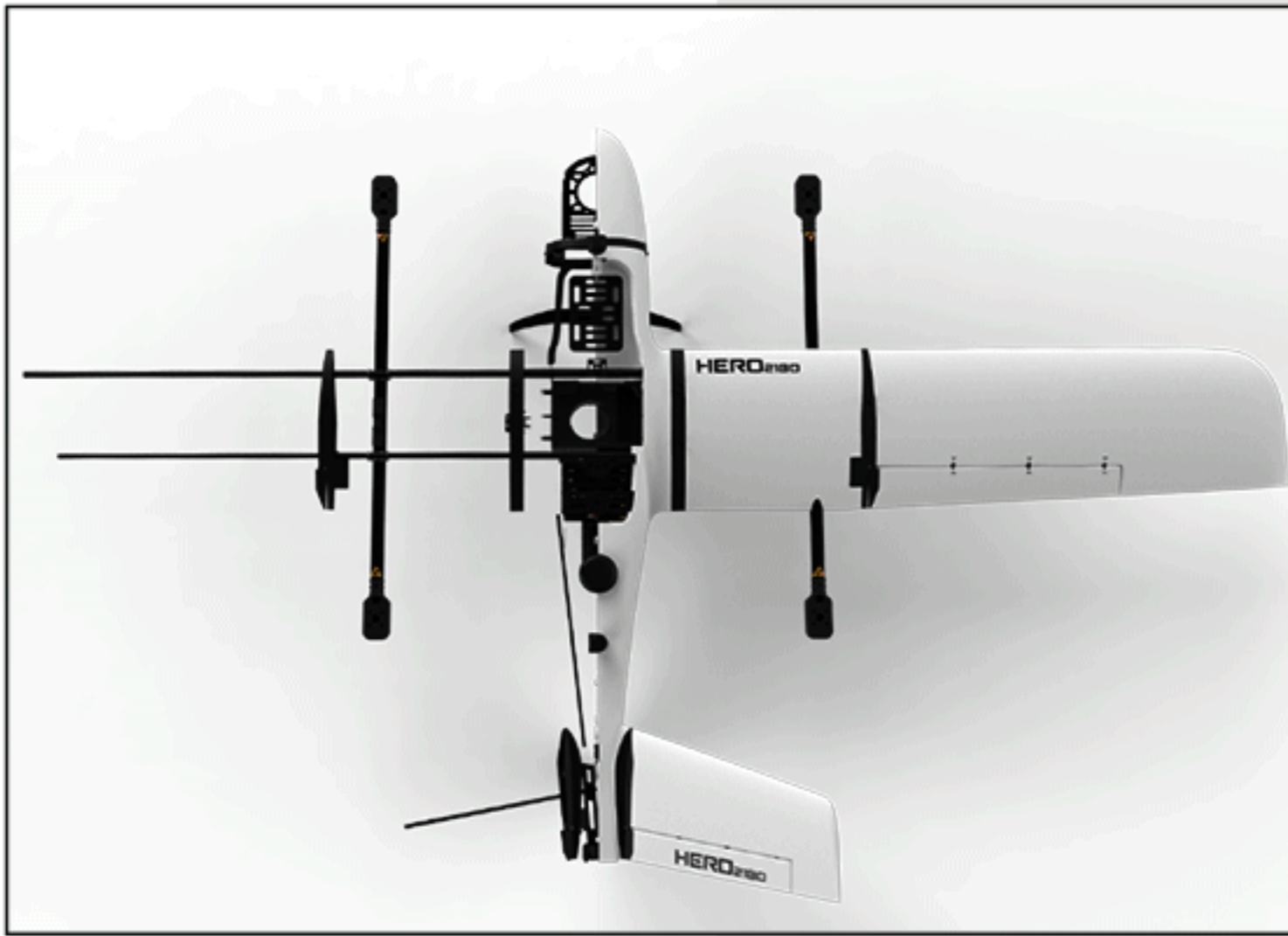

A large number of high-strength and light-weight carbon fibers, wooden boards and PC boards are used in the materials.

In terms of shape, a large number of embedded box structures are used to comprehensively improve the structural strength and rigidity of the body.

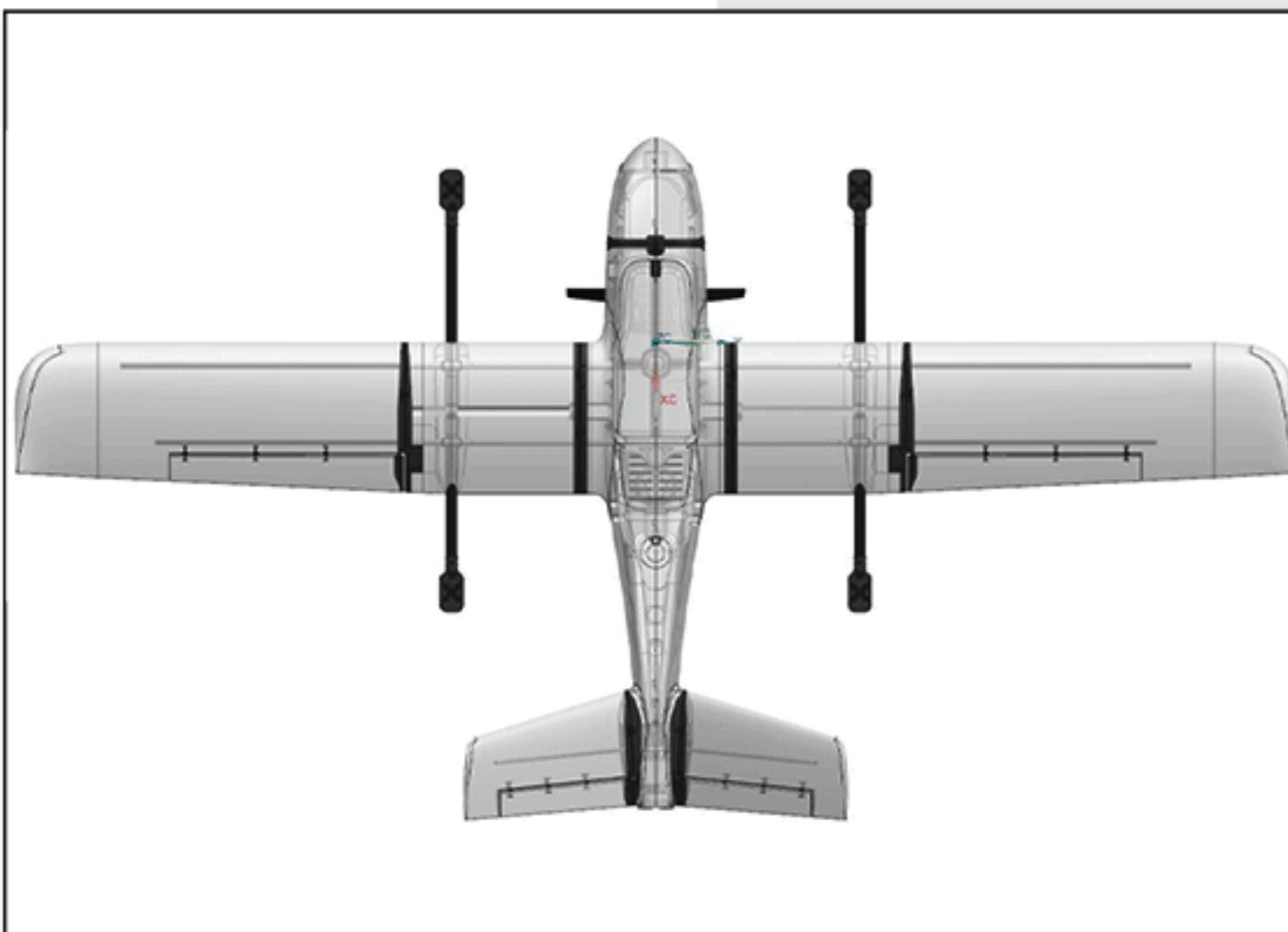
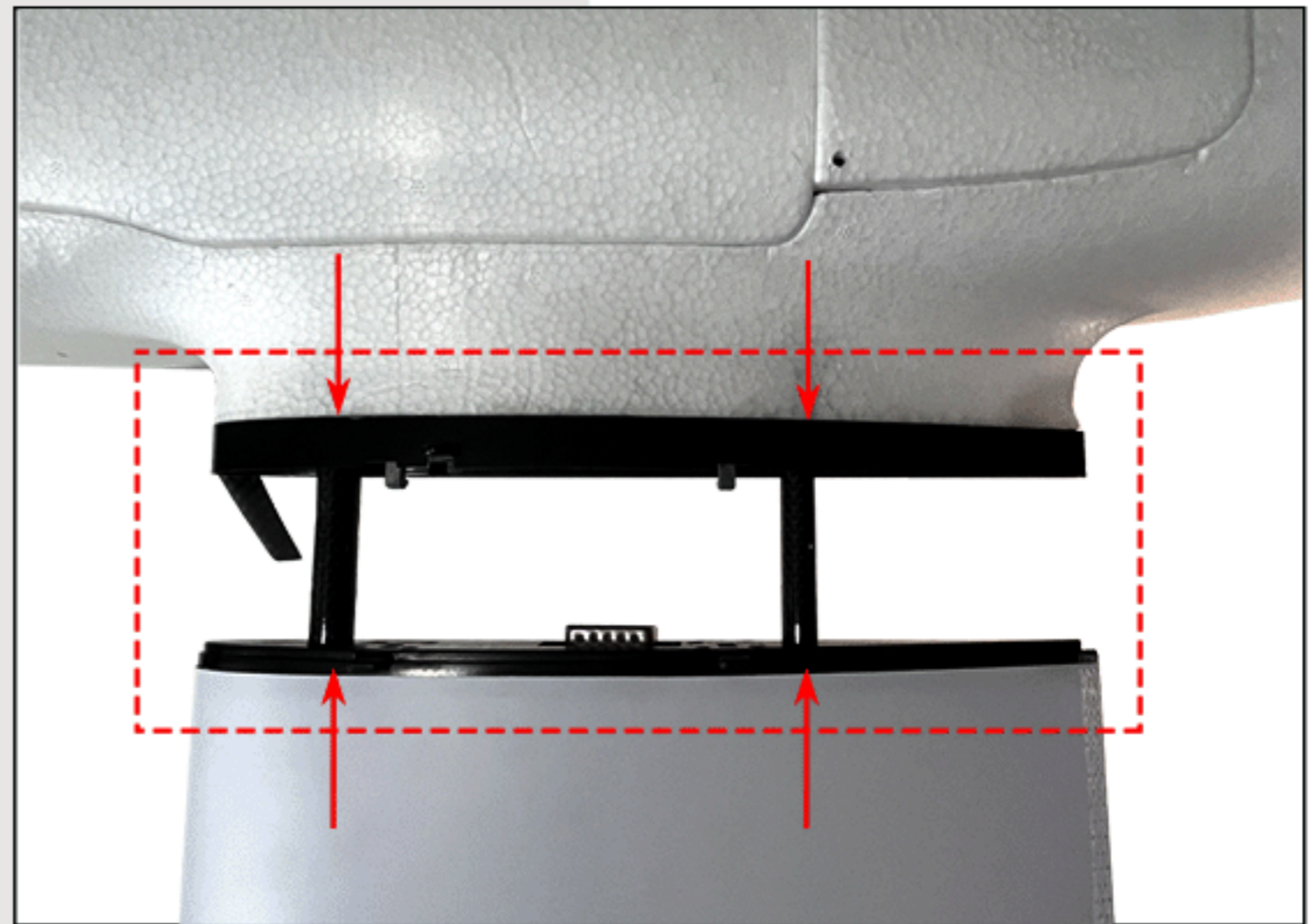

On the basis of the "over-load experiment", according to the structural form and load characteristics of the wing, tail and fuselage, the structure is optimized according to the gram precision to minimize unnecessary weight.

Interchangeable Head

Retrograde VTOL supports a variety of loads, covering two application scenarios of mapping and monitoring.

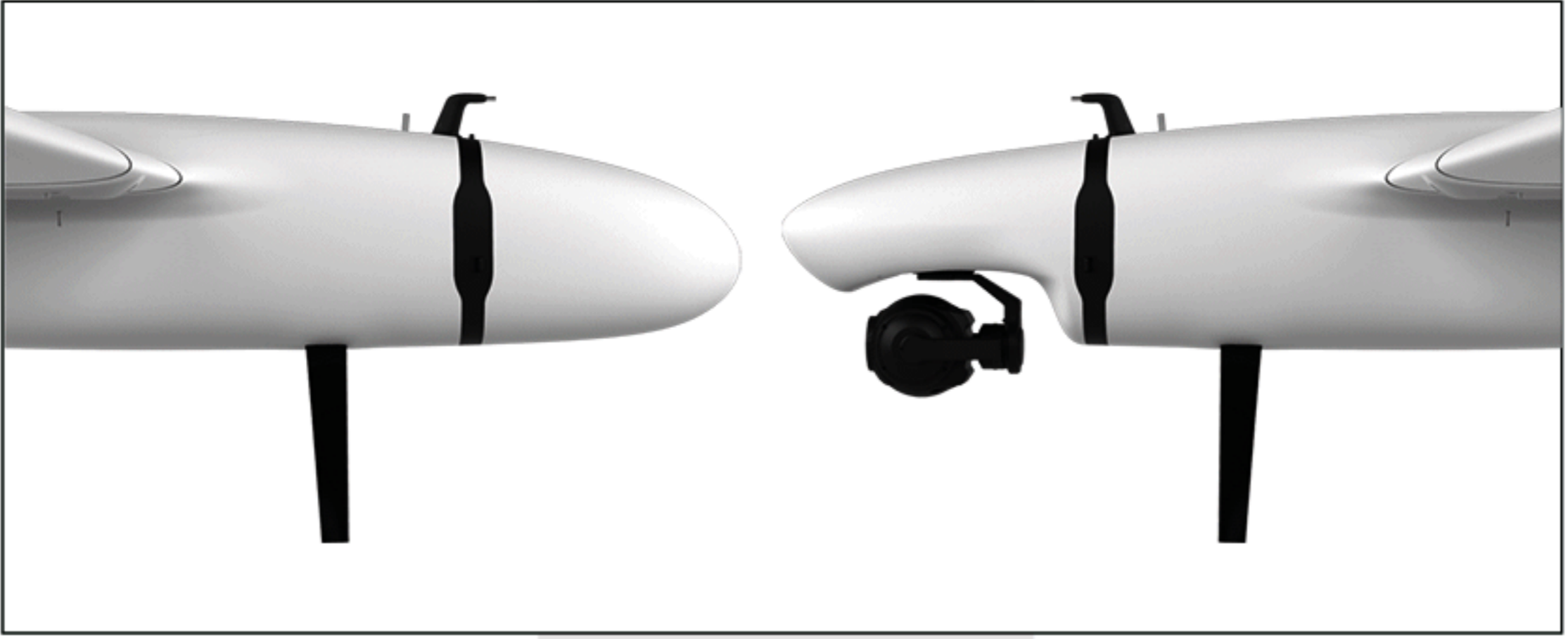

Disassembly Quickly

The wing and tail adopt a tool-free quick disassembly structure, which reduces the installation steps and shortens the disassembly time.



The inner liner of the packing box is made of high-rate EPS foam, with light specific gravity, good impact resistance and shock resistance, and is suitable for long-distance transportation.

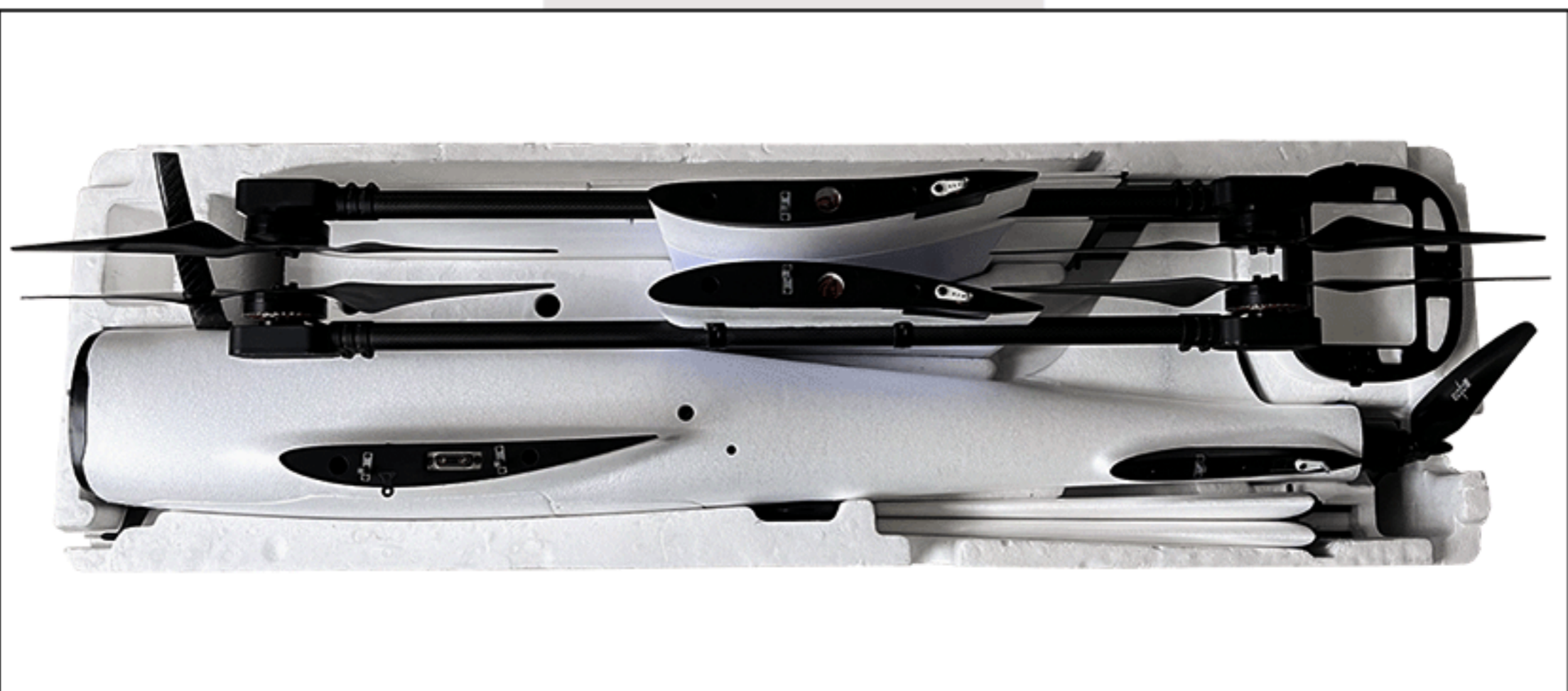

Fuselage Section

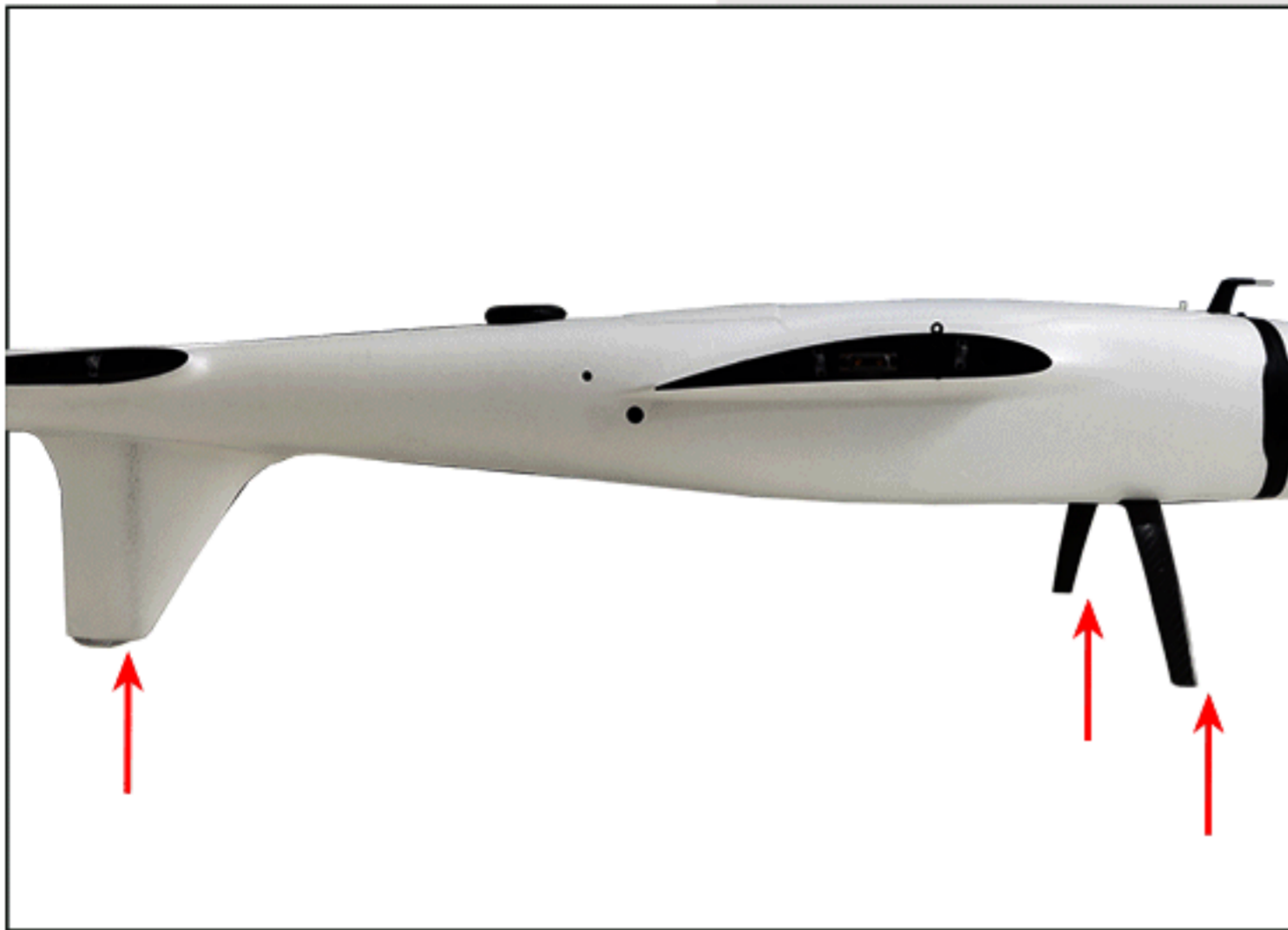

The bottom of the fuselage adopts the rear three-point landing gear, with high ground clearance, large mounting space, and the tail rotor does not touch the ground.

Aircraft center of gravity bulges under fuselage hooks and wing root plastic start (same location).

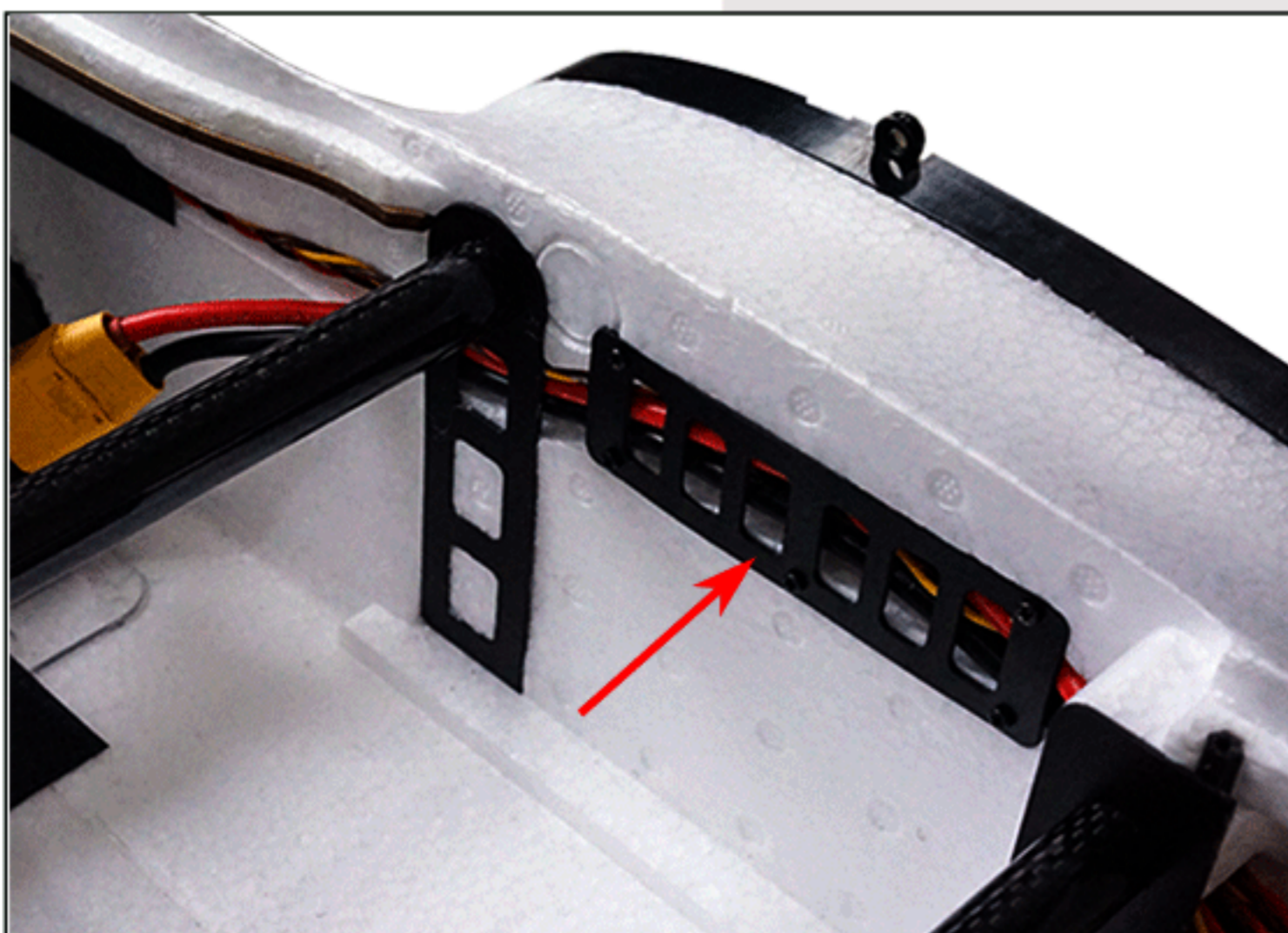
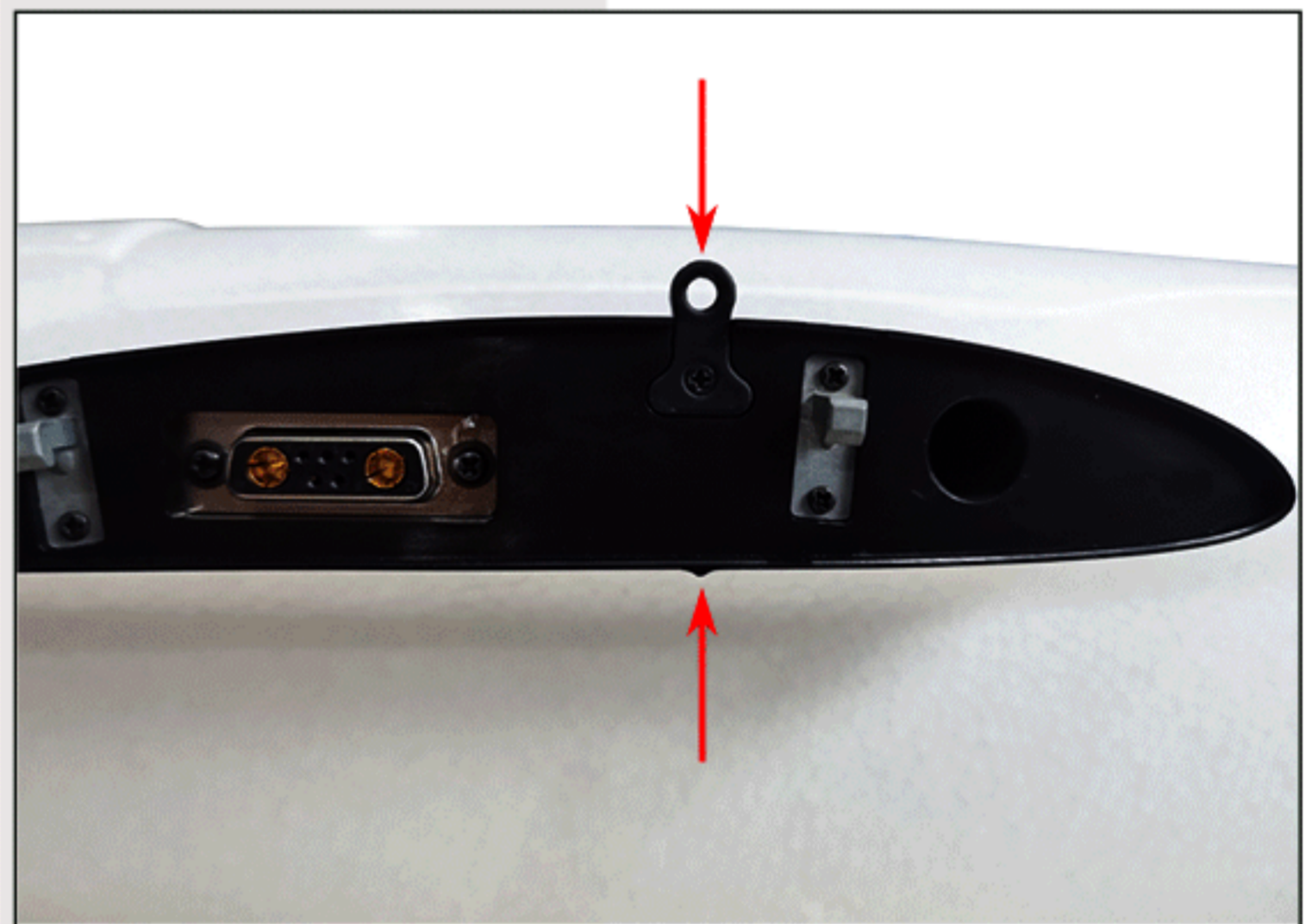

The inner side of the fuselage is designed with wire grooves and removable baffles to facilitate the installation of wires, and the wiring in the cabin is simple and efficient.

Nose Cabin

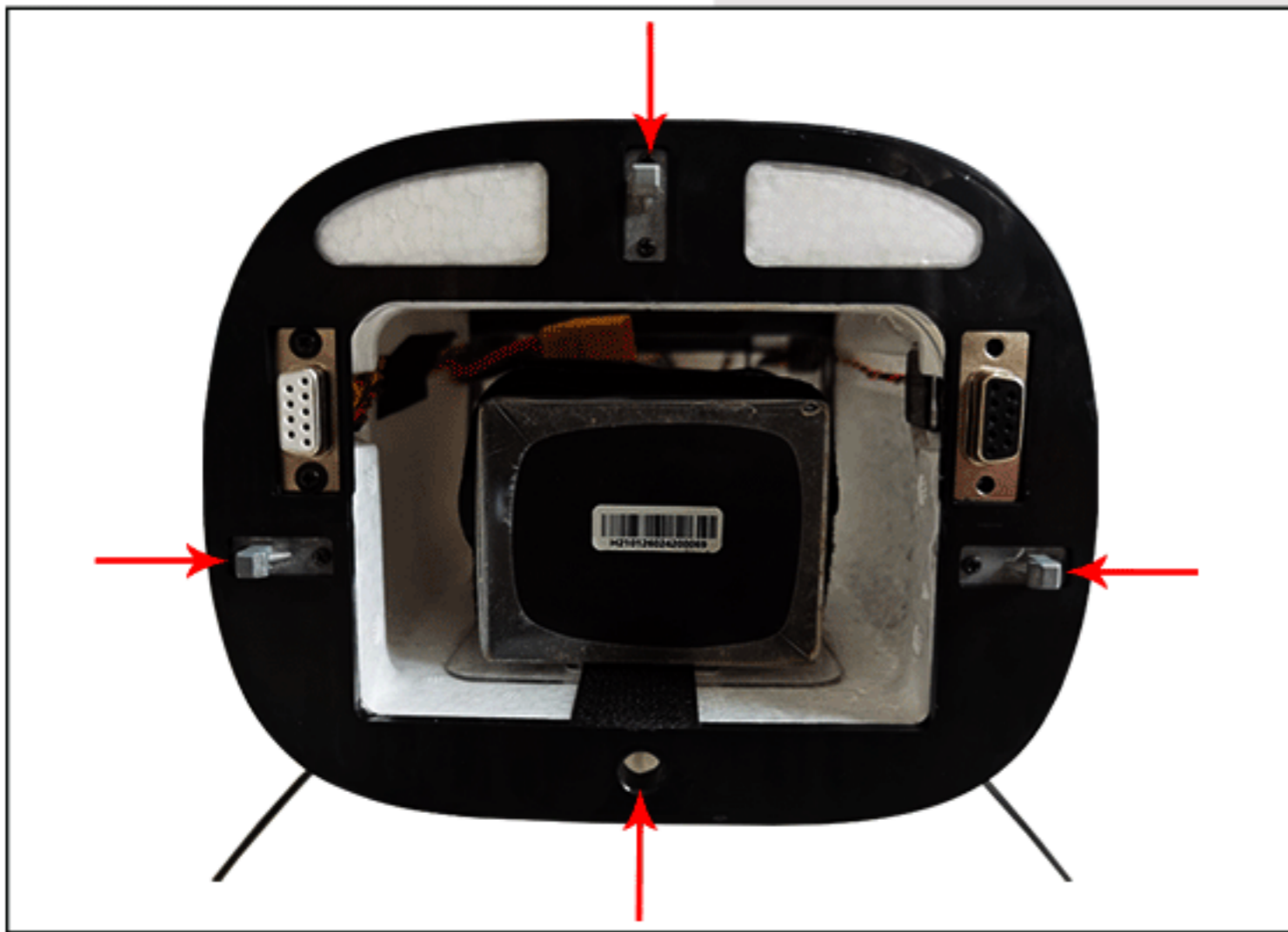

The nose cabin adopts a four-point connection structure, which is stable and reliable and supports quick release.

Two 9-pin connectors are reserved in the nose cabin to support the connection of signals such as image transmission, remote control, and airspeed to the fuselage flight control.

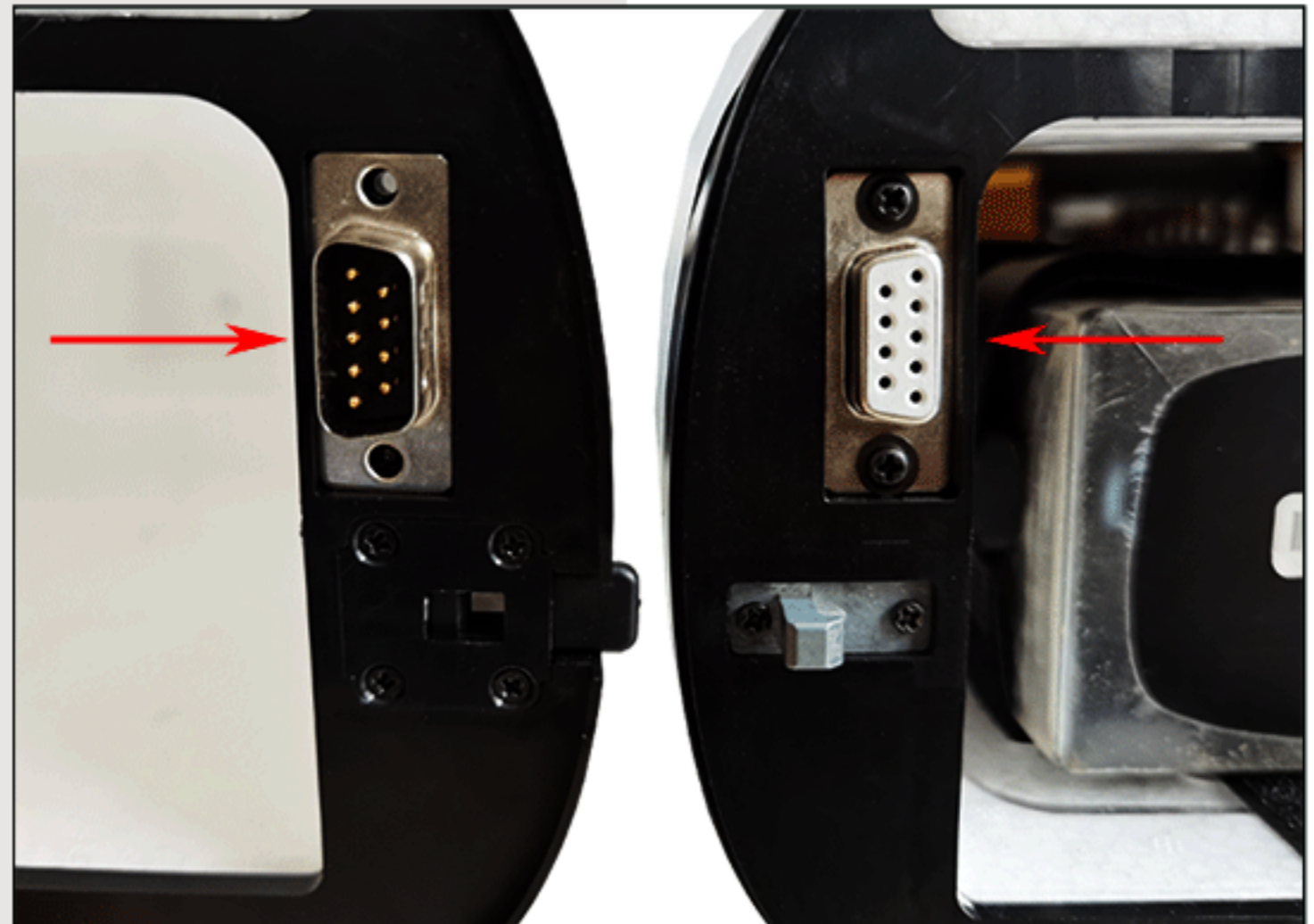

The design file of the nose cabin is open source, and users can customize the mounting plate according to the installation hole position of the pod.

Battery Cabin

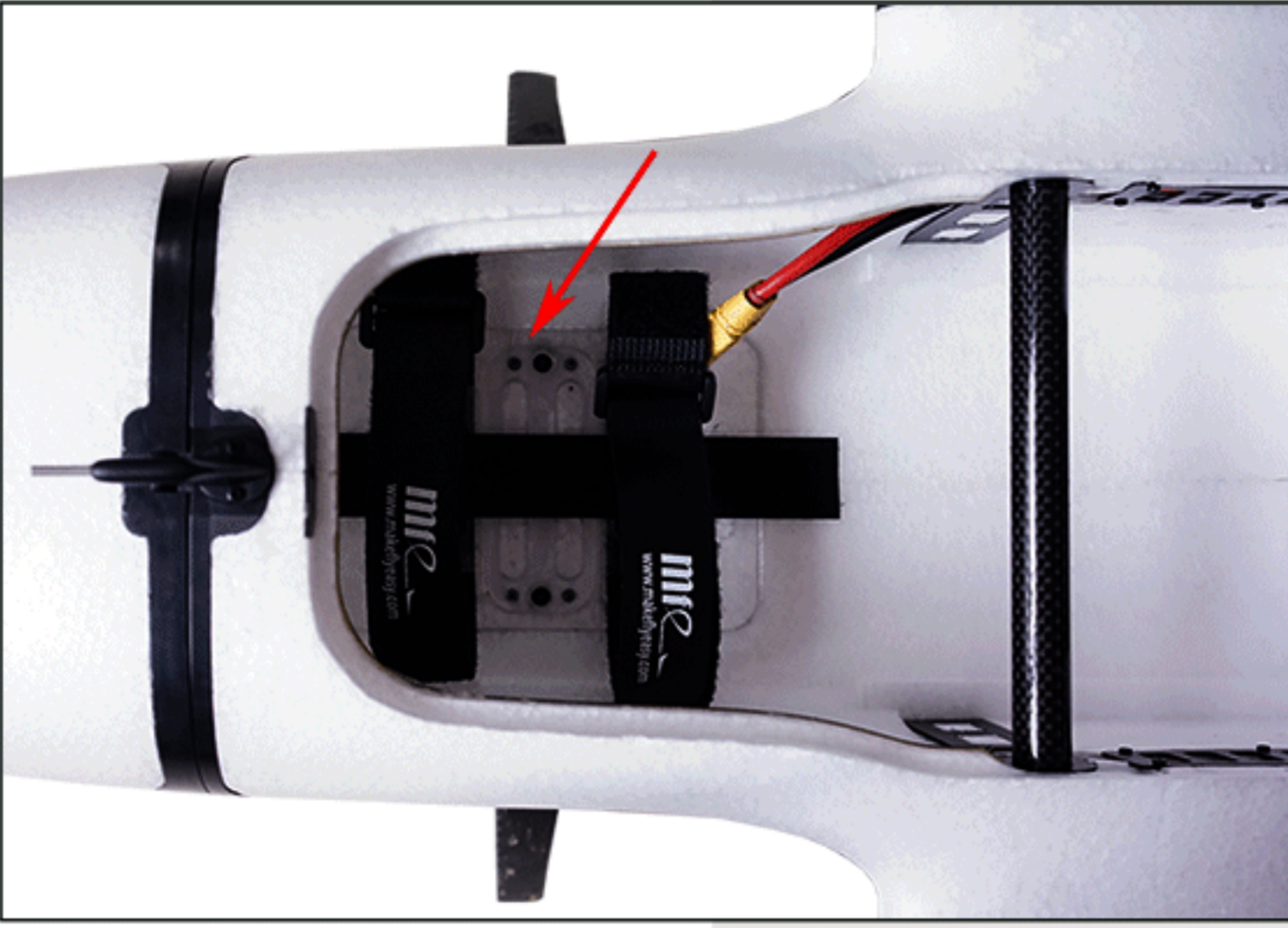

The size of the battery compartment is 326*110*78mm, and the maximum support is 6S@30000mah solid-state lithium battery.

The battery holder is CNC machined from PC board, which is light in weight and has good impact resistance.

The battery tie is made of fiber-reinforced plastic, which is strong and durable. The layout of the tie is reasonable and easy to fix.

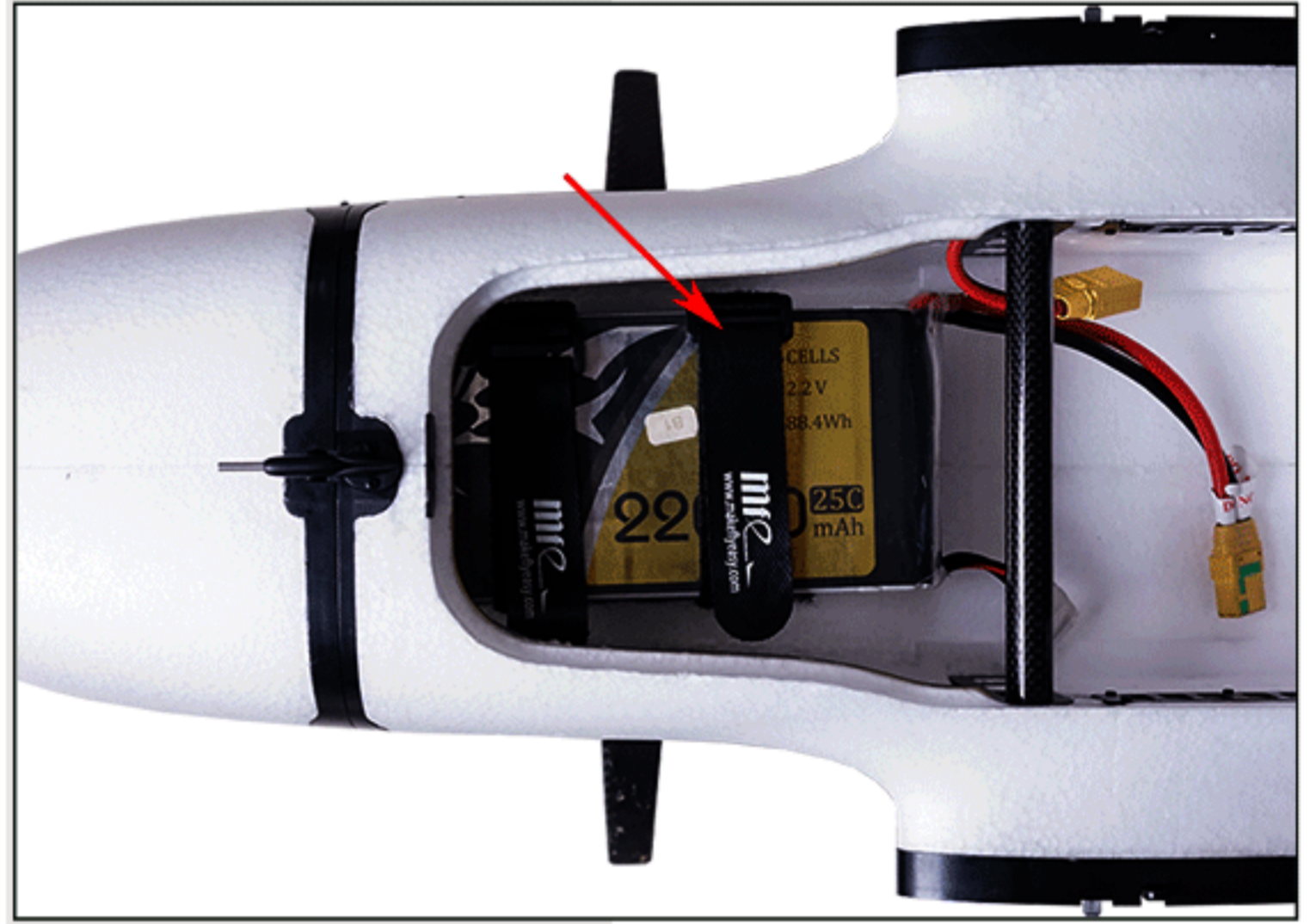

Load Cabin

The size of the payload bay is 144*160*80mm, which can accommodate Sony A7R series cameras or five-lens half-frame tilt cameras.

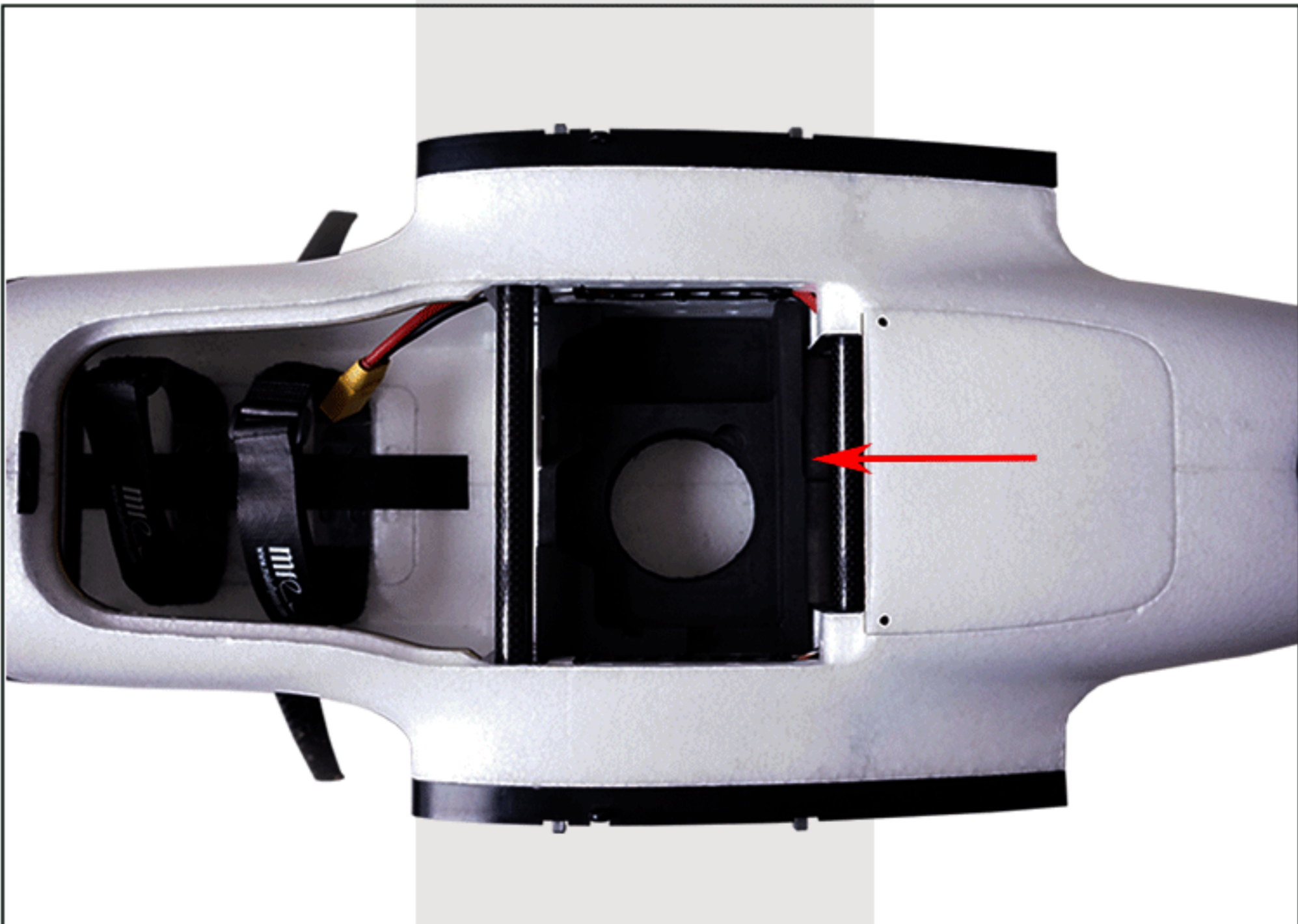

Flight Control Cabin

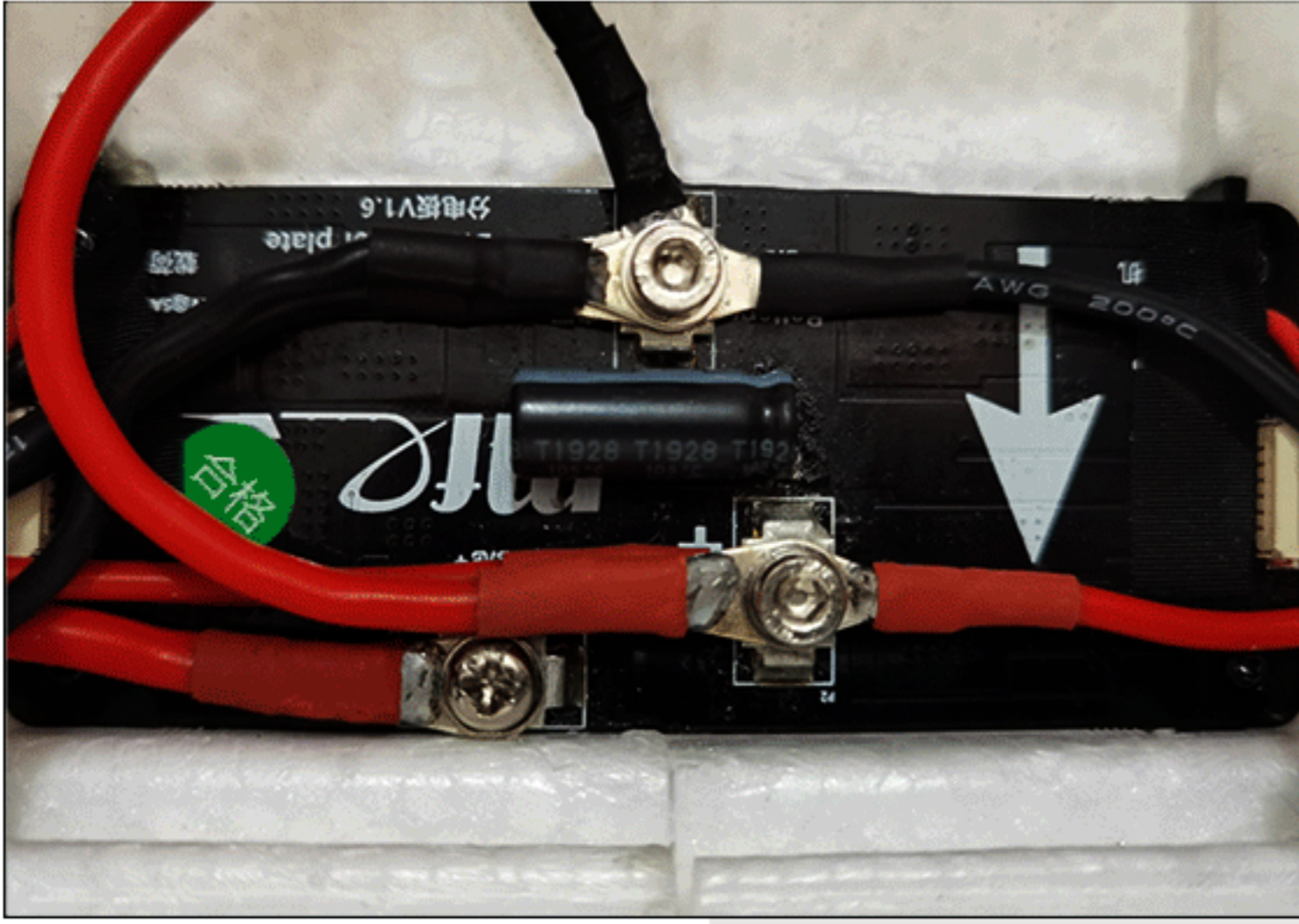

The flight control cabin adopts a layered design structure to improve space utilization. The bottom layer can install the distribution board and the landing radar.

The middle layer can install flight control, which is compatible with open source/commercial flight control installation.



The top layer can install PPK or image transmission equipment.



The flight control hatch supports screw fixing to prevent foreign objects from falling, which is both beautiful and dust-proof.

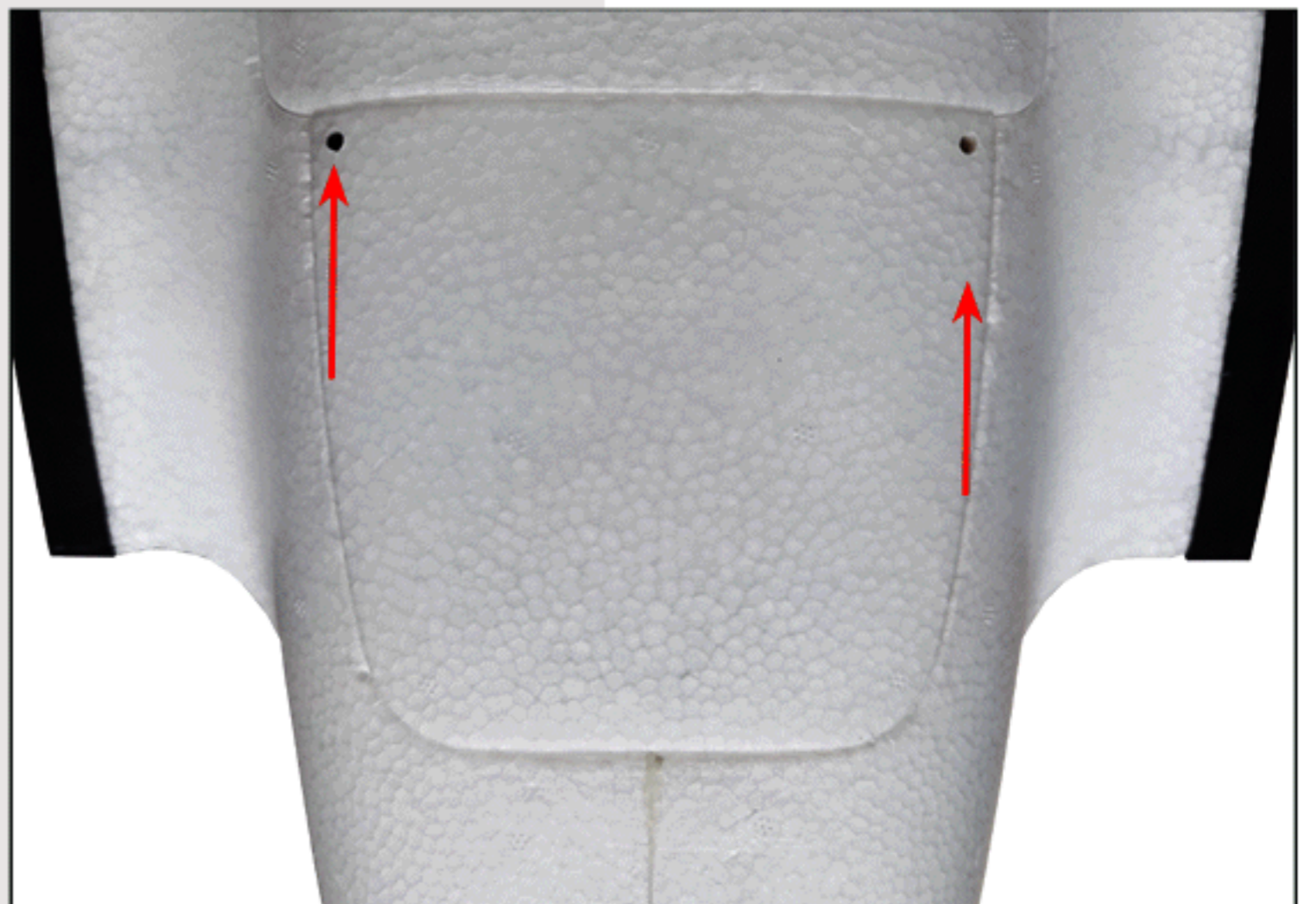

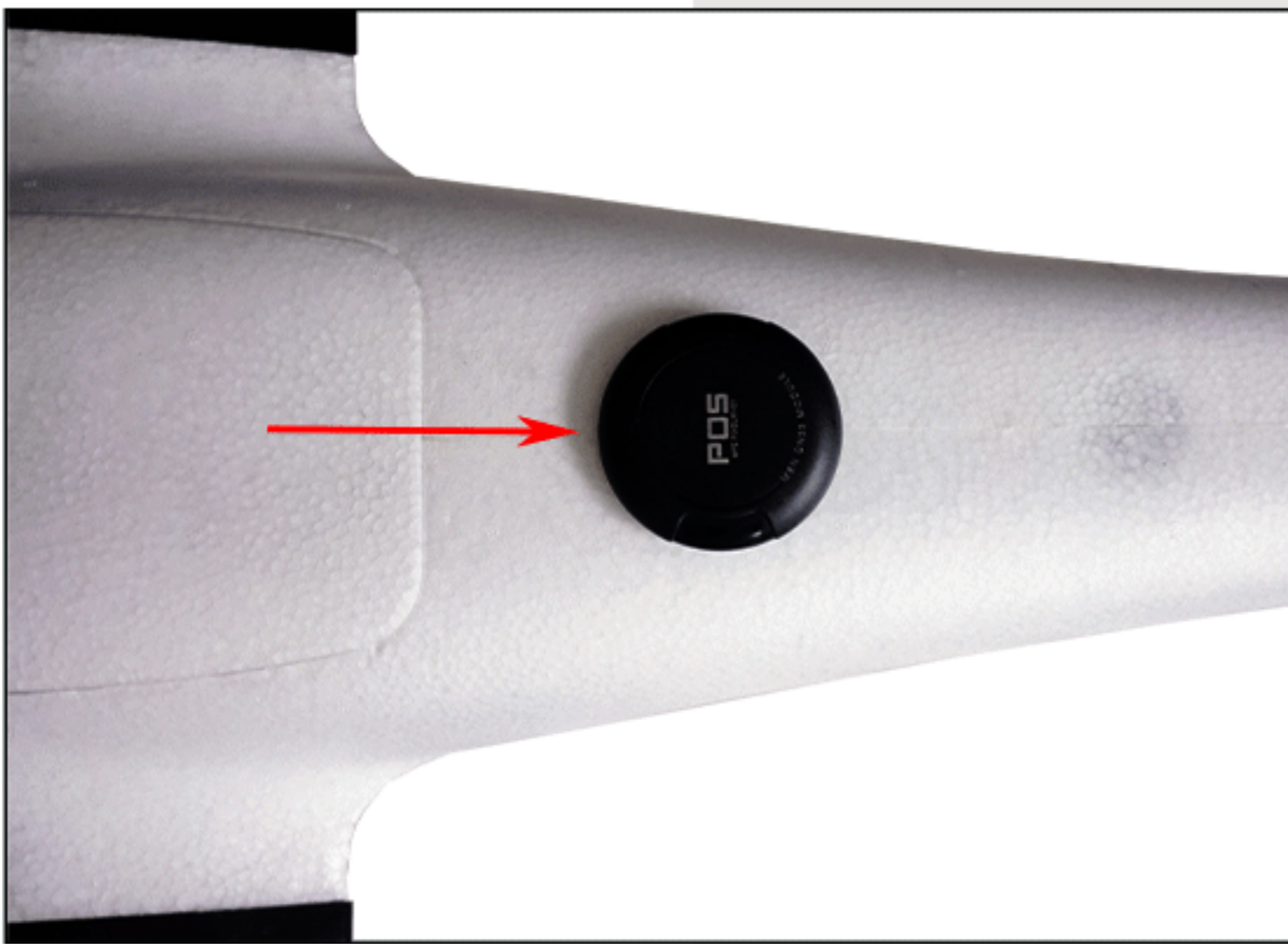

The GPS and compass modules are placed above and behind the flight control cabin, and the electromagnetic environment is clean.

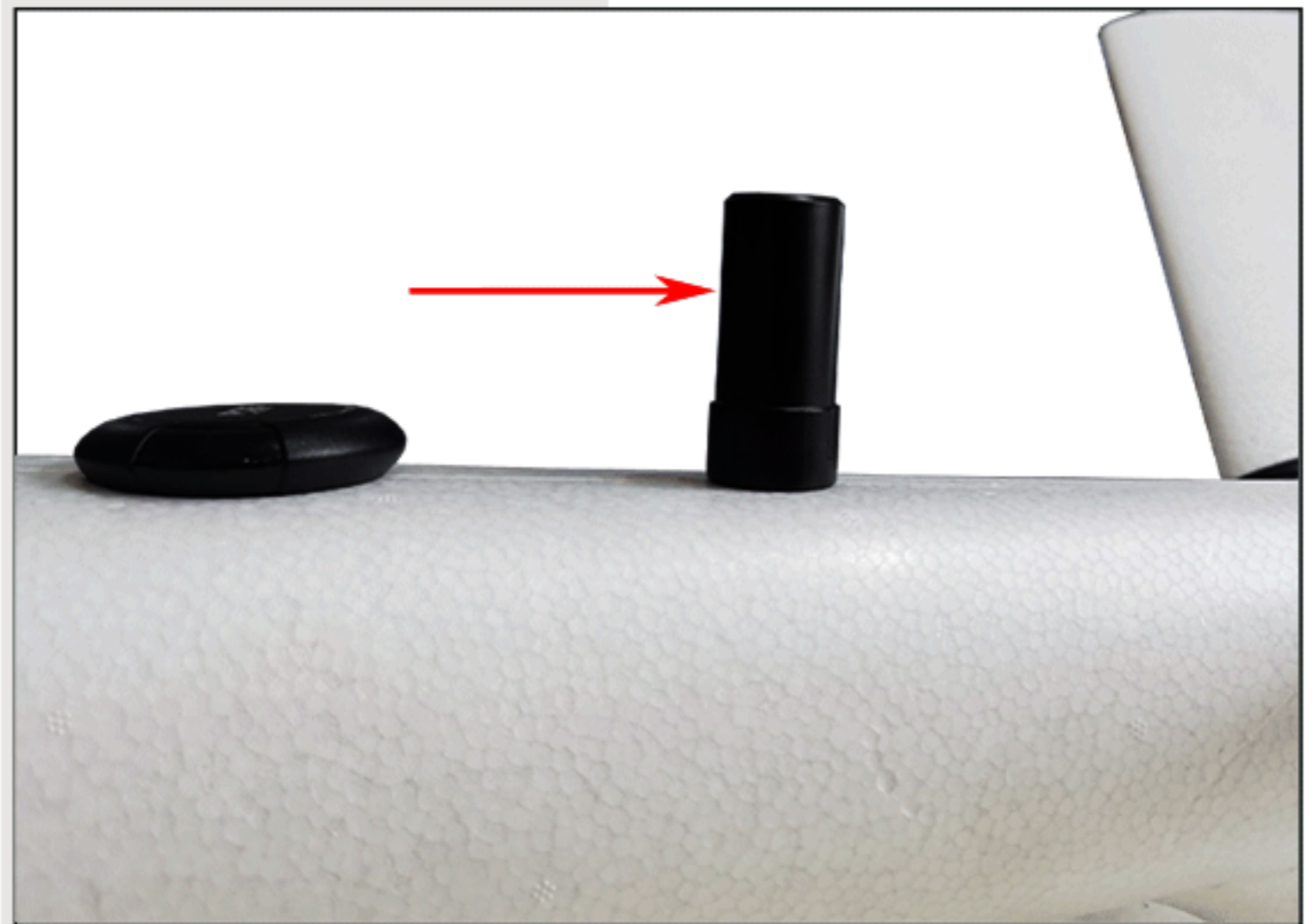

The position of the PPK antenna is reserved behind the GPS cabin, which is convenient to install the PPK antenna and improve the accuracy of POS data.

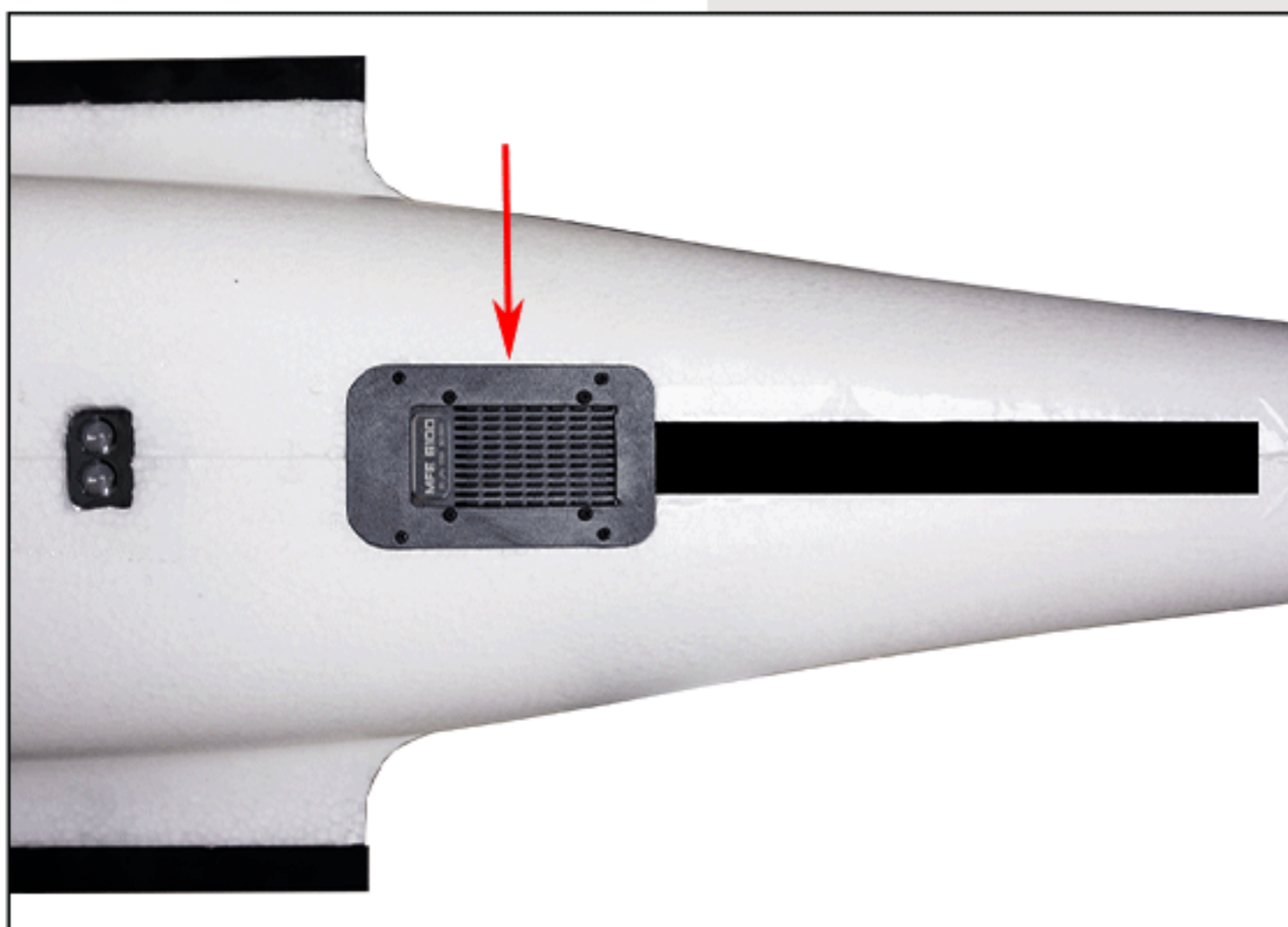

The tail push ESC is placed under the rear of the flight control cabin, with an external aluminum shell, which has a good heat dissipation effect.

Tail Section

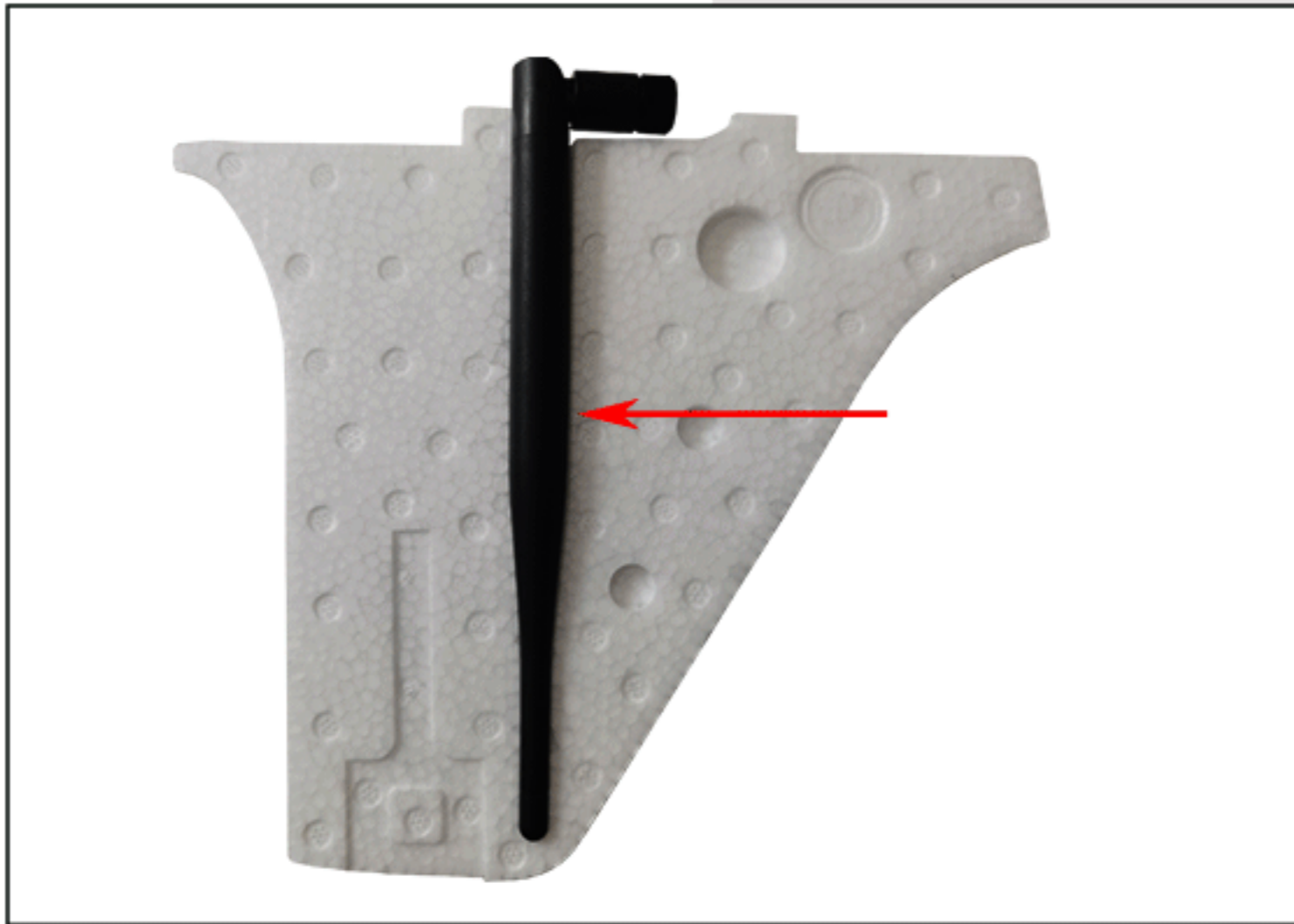

The 195mm rat tail glue stick antenna can be pre-buried in the vertical tail, which not only improves the support strength of the vertical tail, but also has a clean electromagnetic environment and

The V-tail adopts a tool-free quick-release structure, which is automatically locked with one push and pulled out immediately with one push.

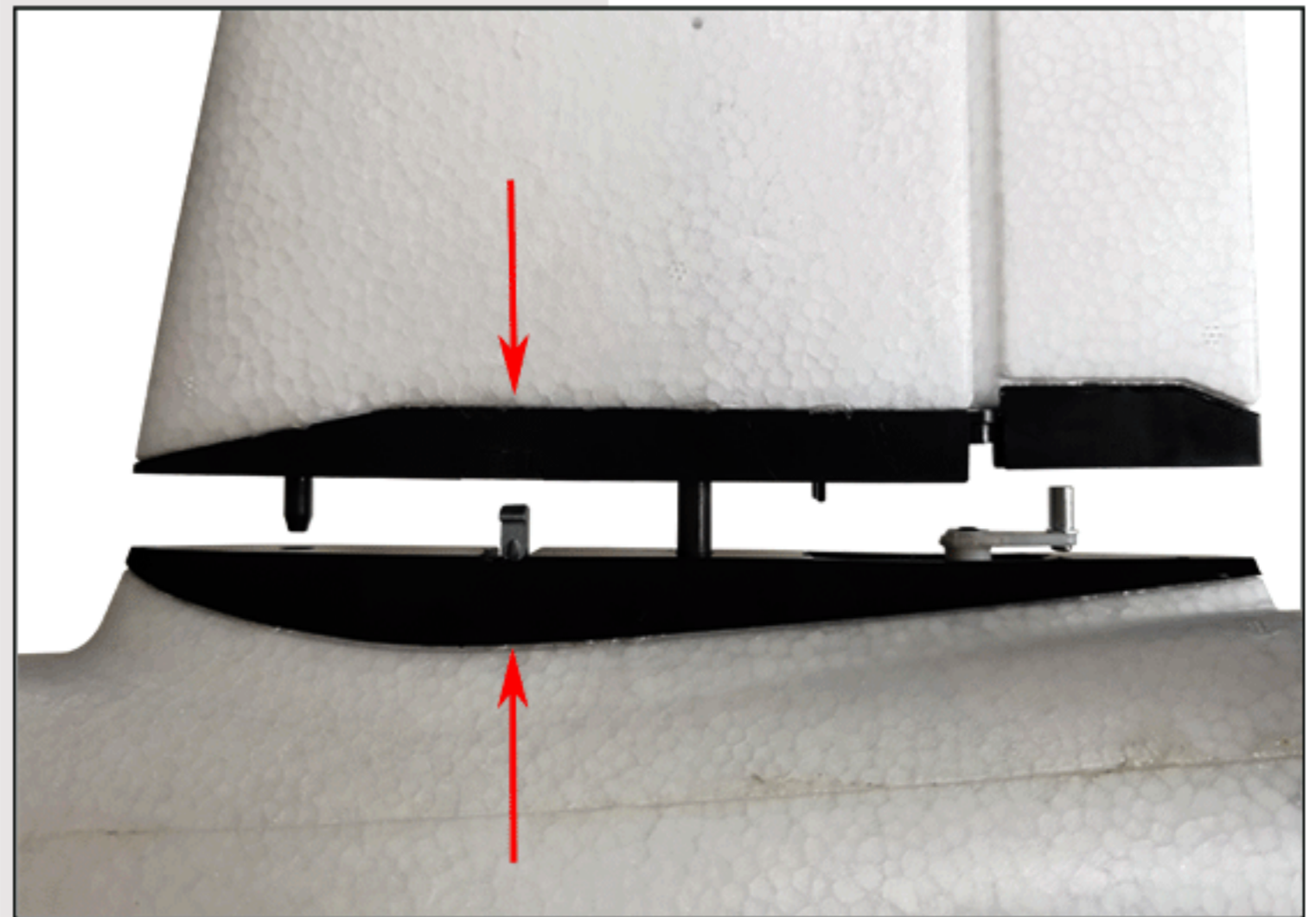

The tail servo does not need to be pre-embedded for easy maintenance.

The servo rocker arm is designed with built-in, even if the rocker arm drive column is loose, the rudder surface can be accurately executed.

Wing Structure

The wing can be split into a wing root segment and a wing tip segment to further reduce the storage volume.

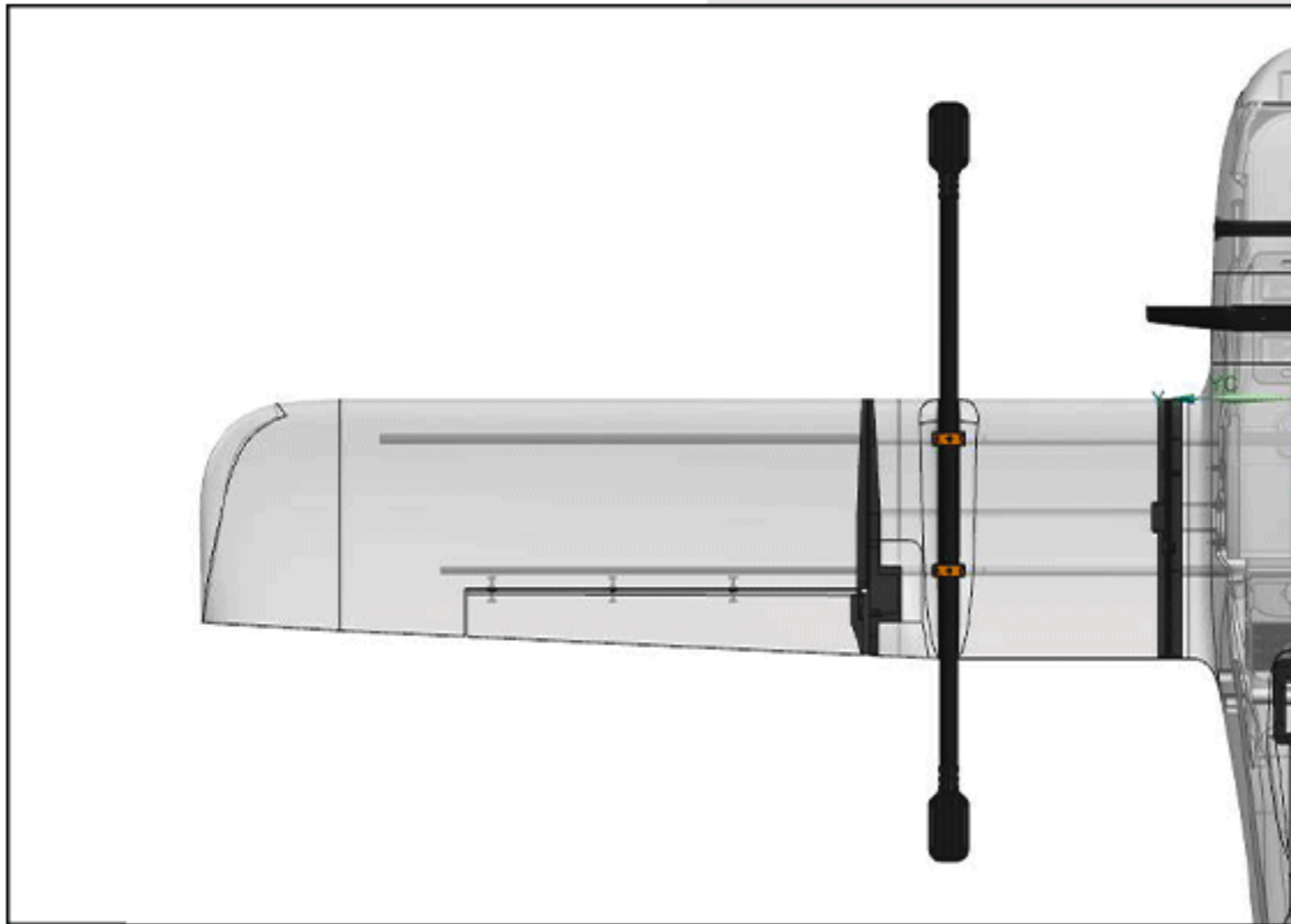
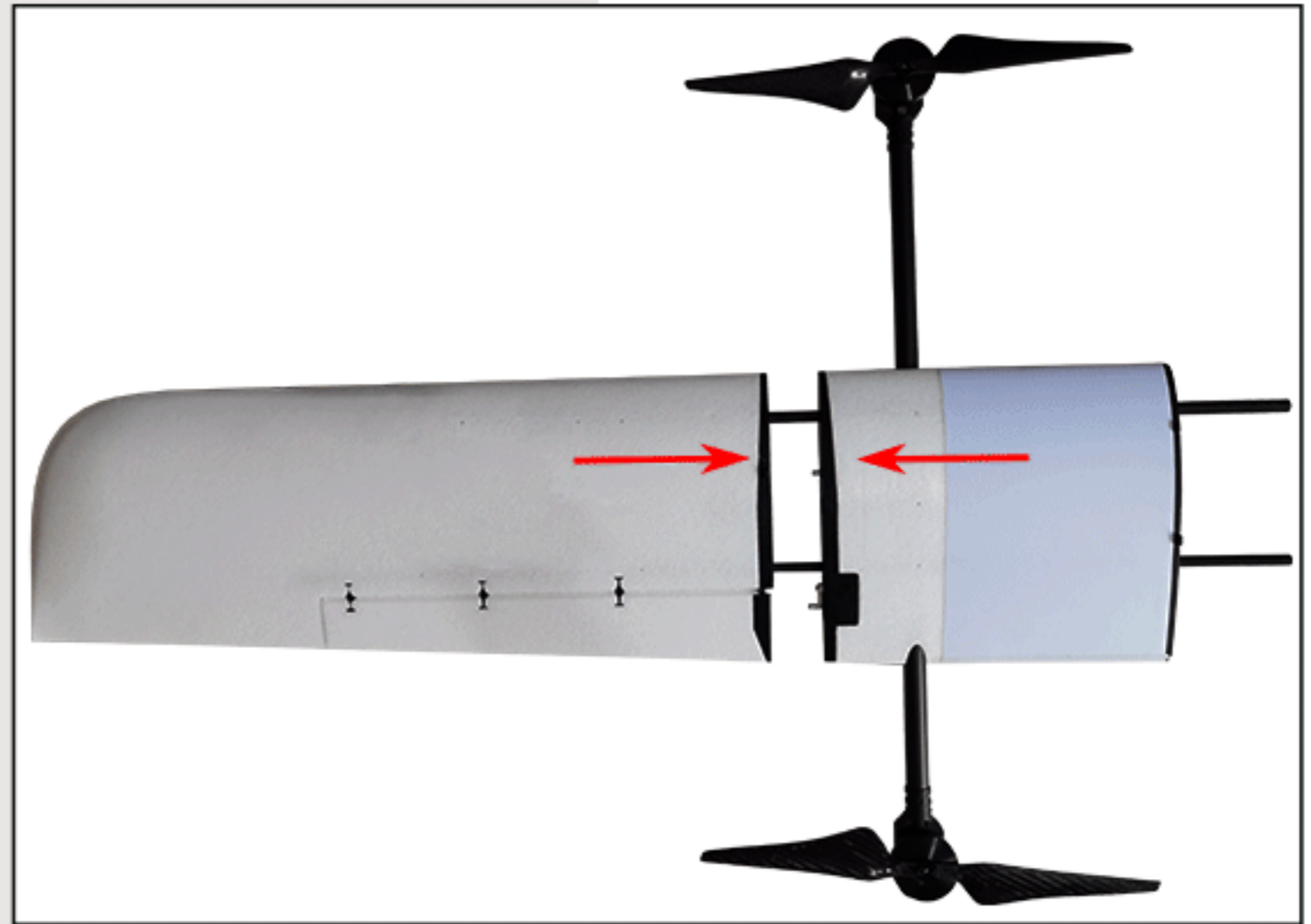

The wing is composed of main carbon tubes, auxiliary carbon tubes, vertical arms, and plastic parts to form a frame structure to improve the overall strength.

The wing root section and the fuselage are separated electrically and structurally through 5+2 high-current connectors.

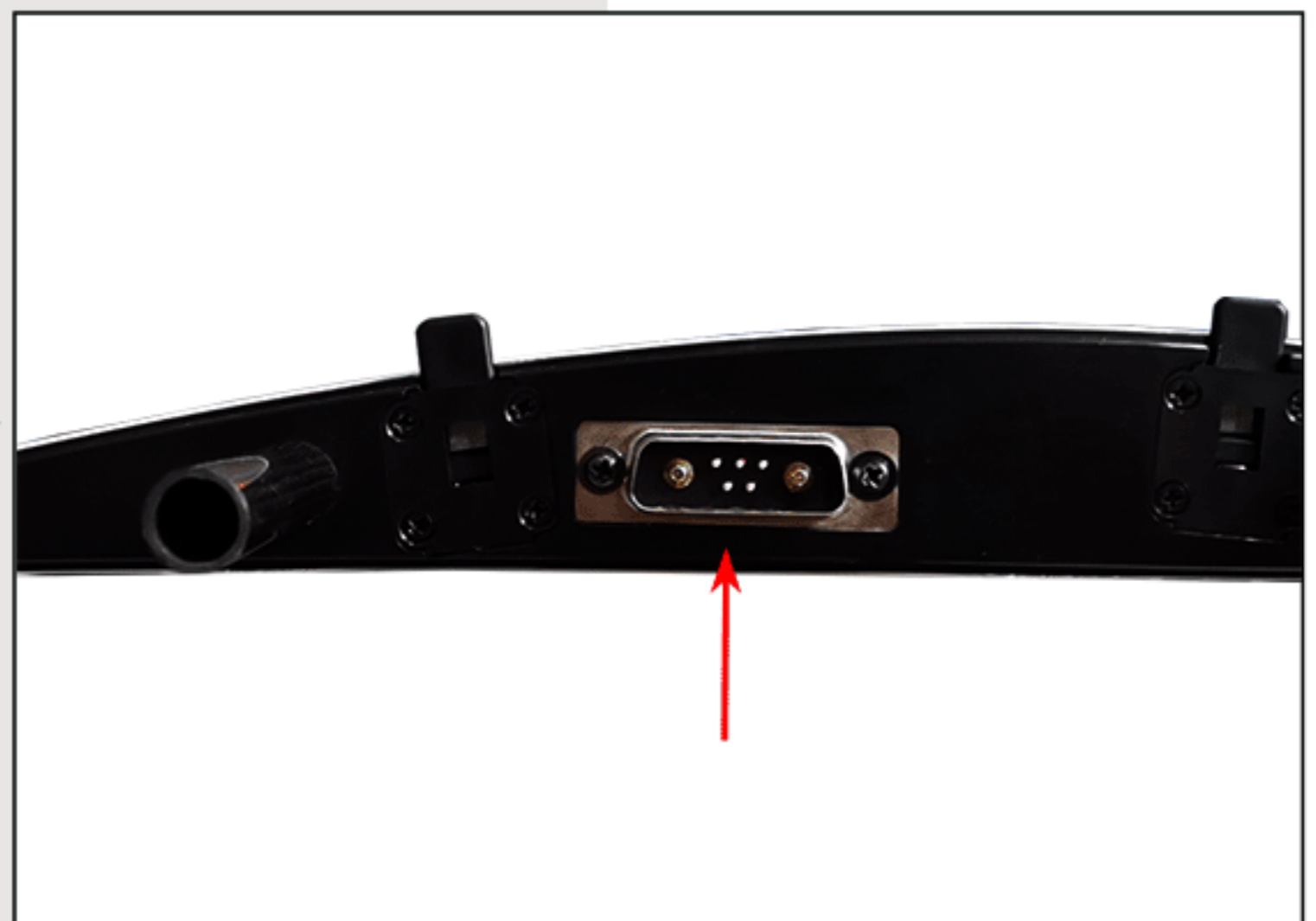



The surface of the wing root section is reinforced with 3M stickers, which enhances the rigidity of the aircraft and improves the torsion resistance of the wing.

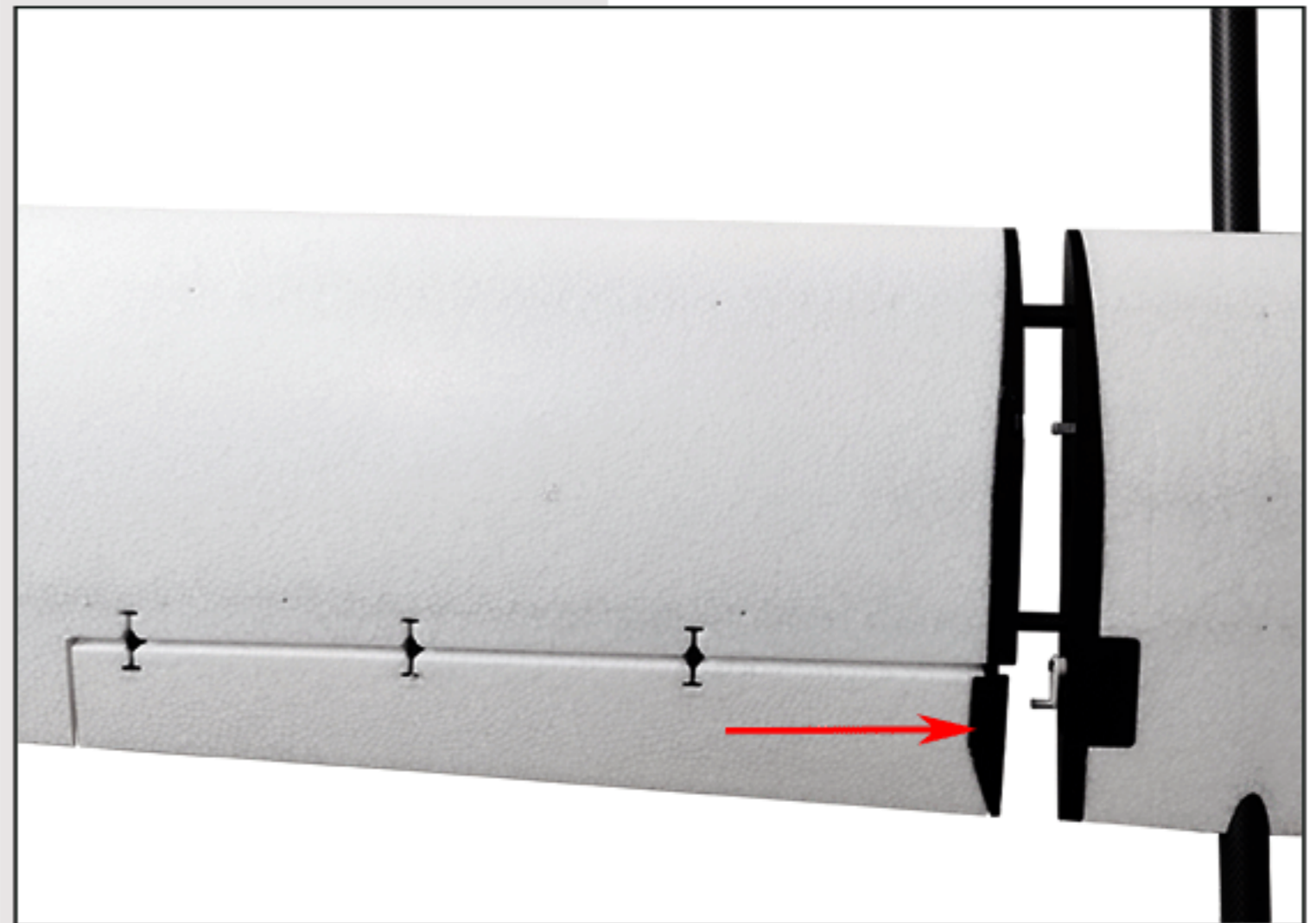

The wing rudder adopts servo rocker arm direct drive design, simple and durable

VTOL Rotor Arm

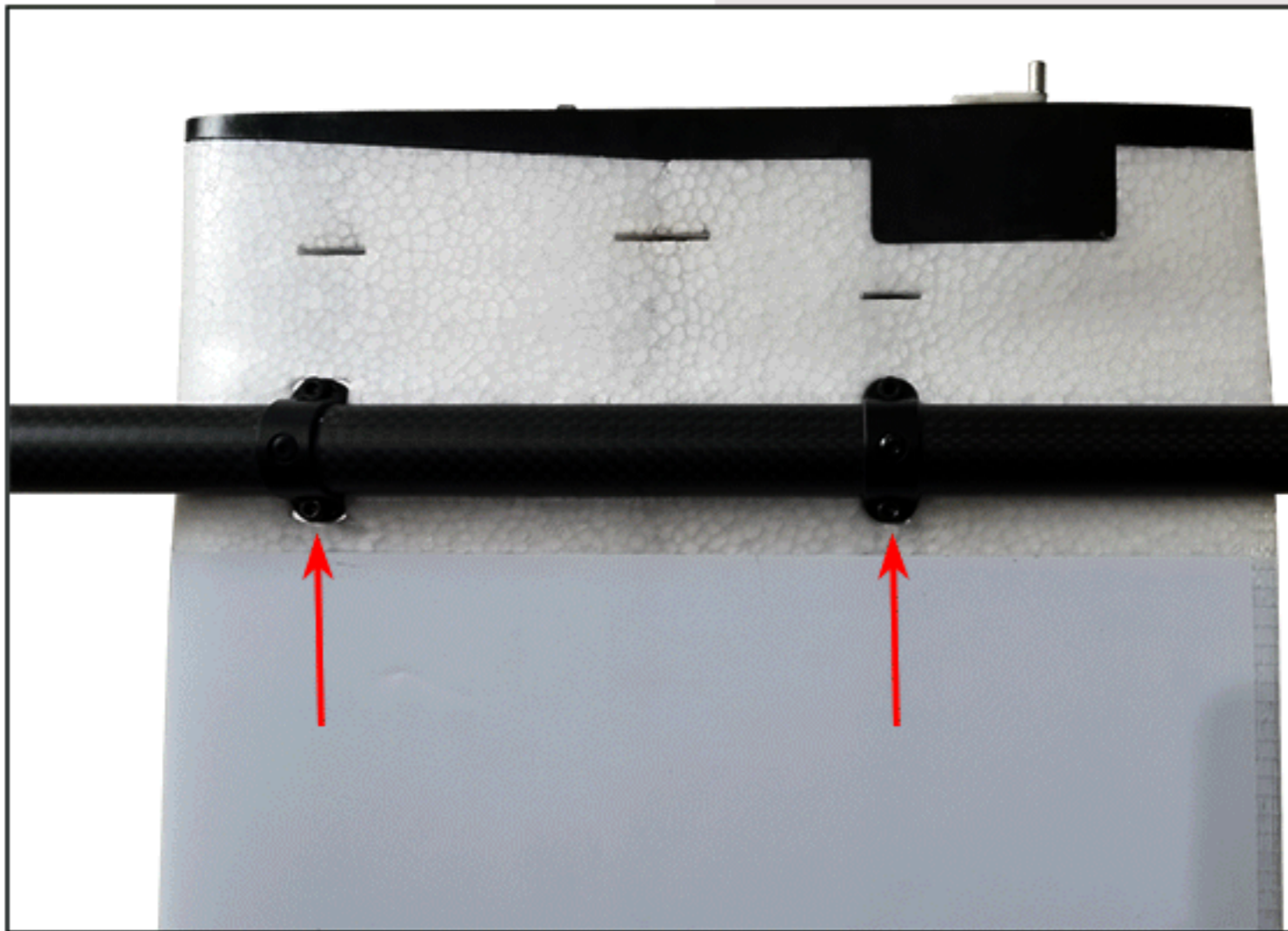

The VTOL Rotor Arm is fixed by an aluminum alloy wrapping structure, which can be installed and removed as a whole for easy maintenance.

The middle section of the VTOL Rotor Arm is open to facilitate the installation of ESC and servo cables.

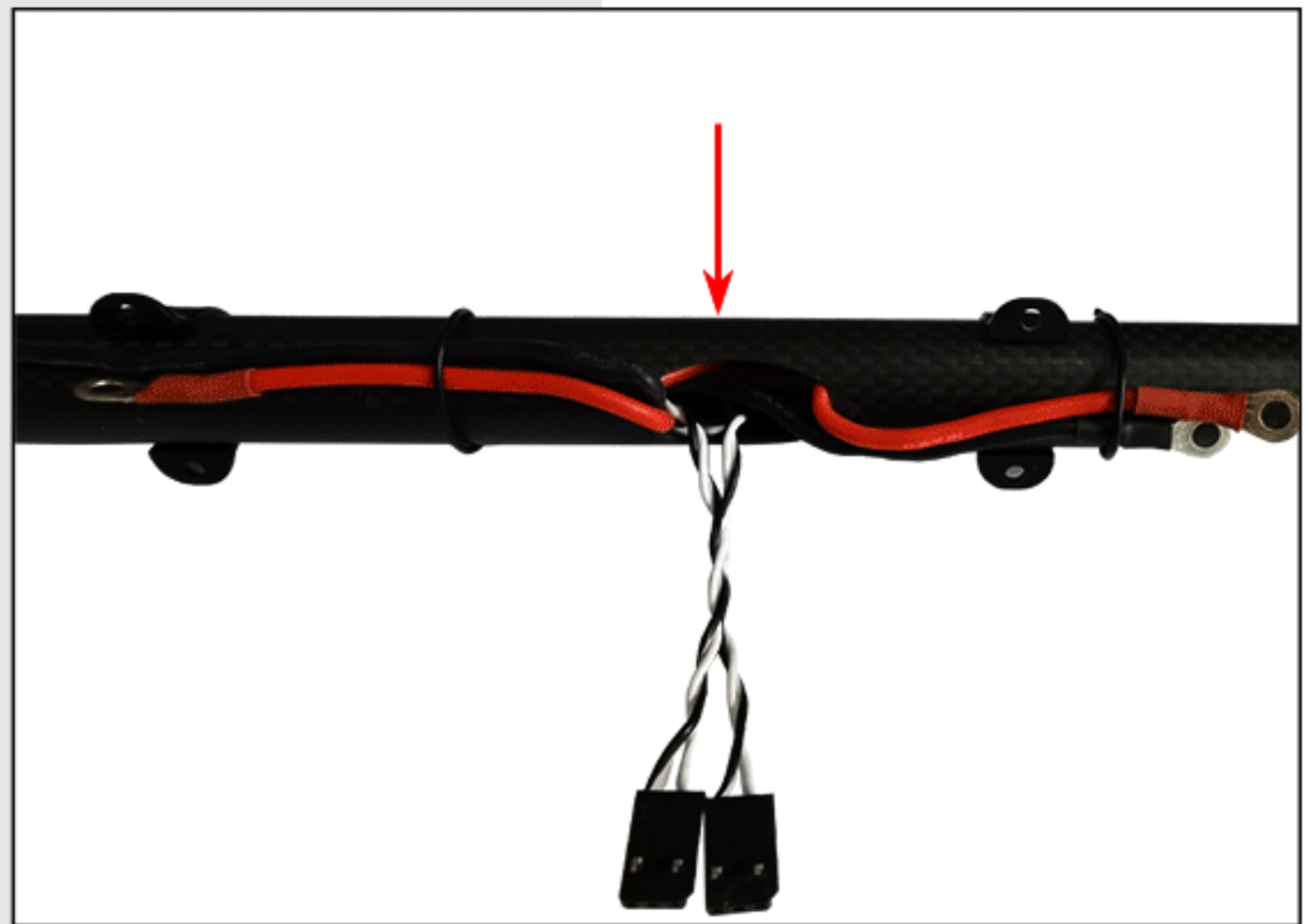

(Optional) Wiring board
Quick-release wing power system

The motor seat supports the largest outer rotor $\phi 65\text{mm}$ motor, and the size of the ESC cabin is $67*31*12\text{mm}$

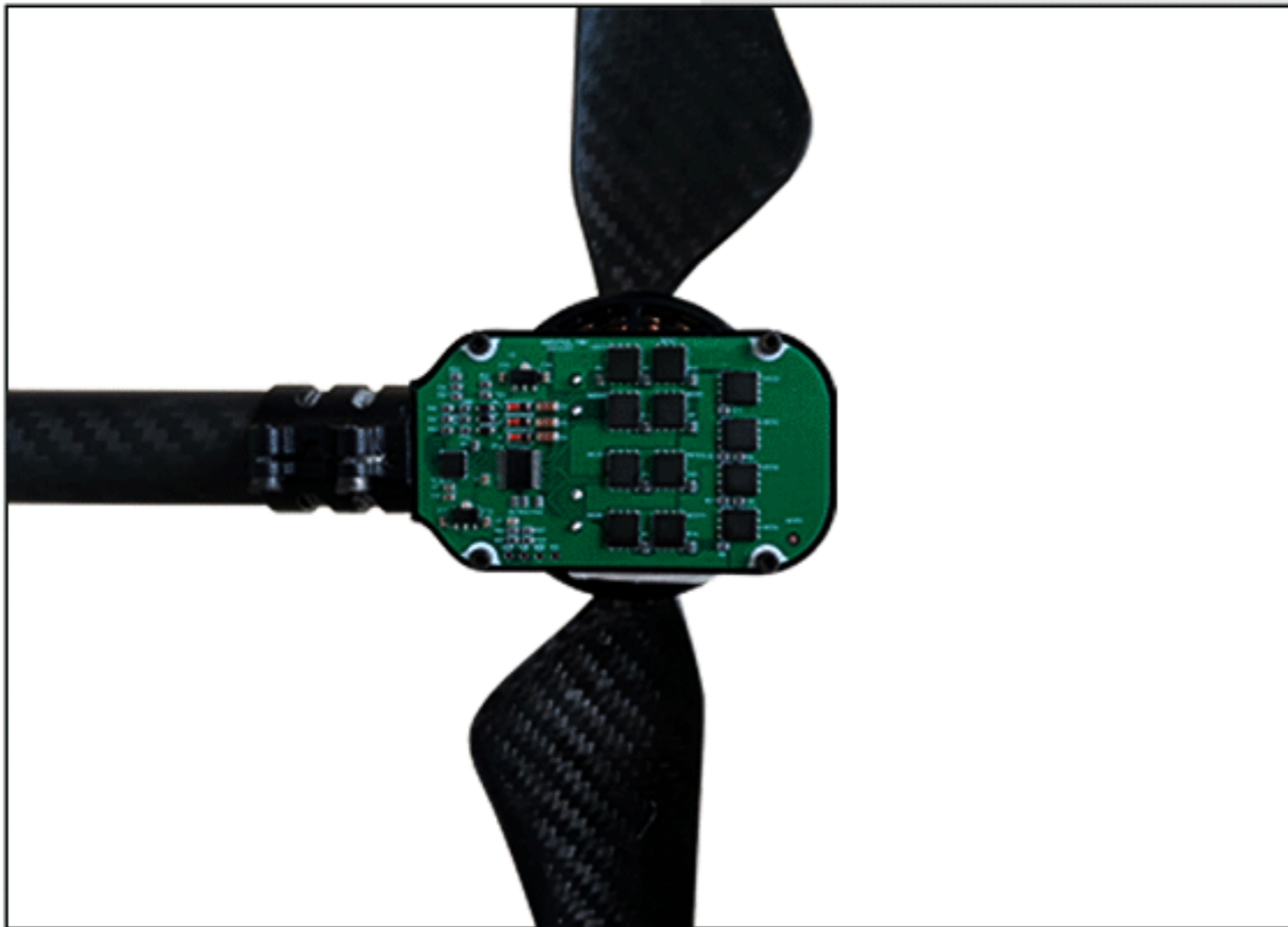

(Optional) Customized ESC, waterproof and dustproof, good heat dissipation effect, no fear of harsh field environment.

Technical Support



Please read the installation documentation before installation, most of the information you need is here.

<https://doc.makeflyeasy.com>

Welcome to join the makefly-easy drone technology exchange QQ group: 293334316. Peers and technical support are waiting for you here!

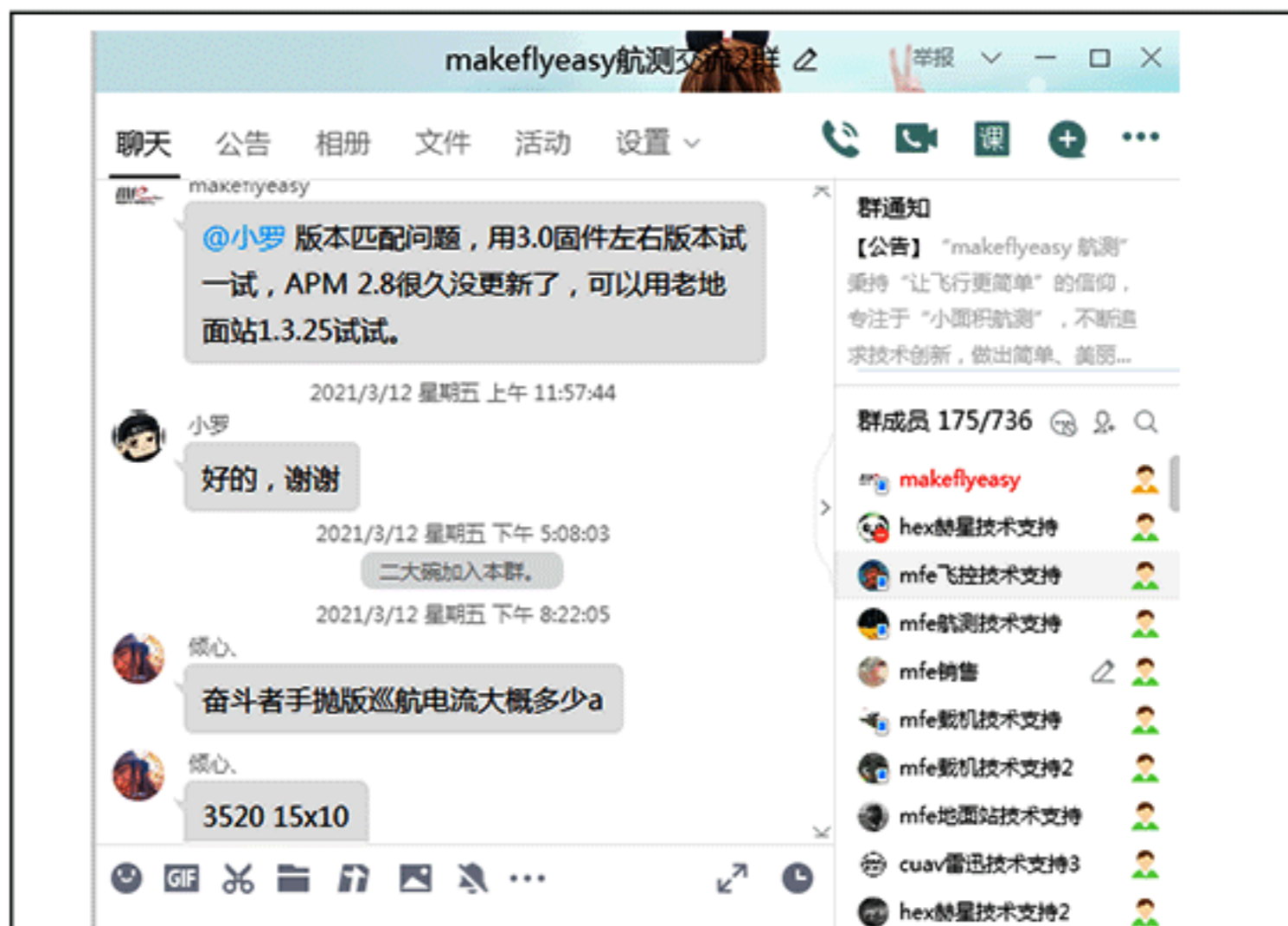

Electrical Connection Diagram

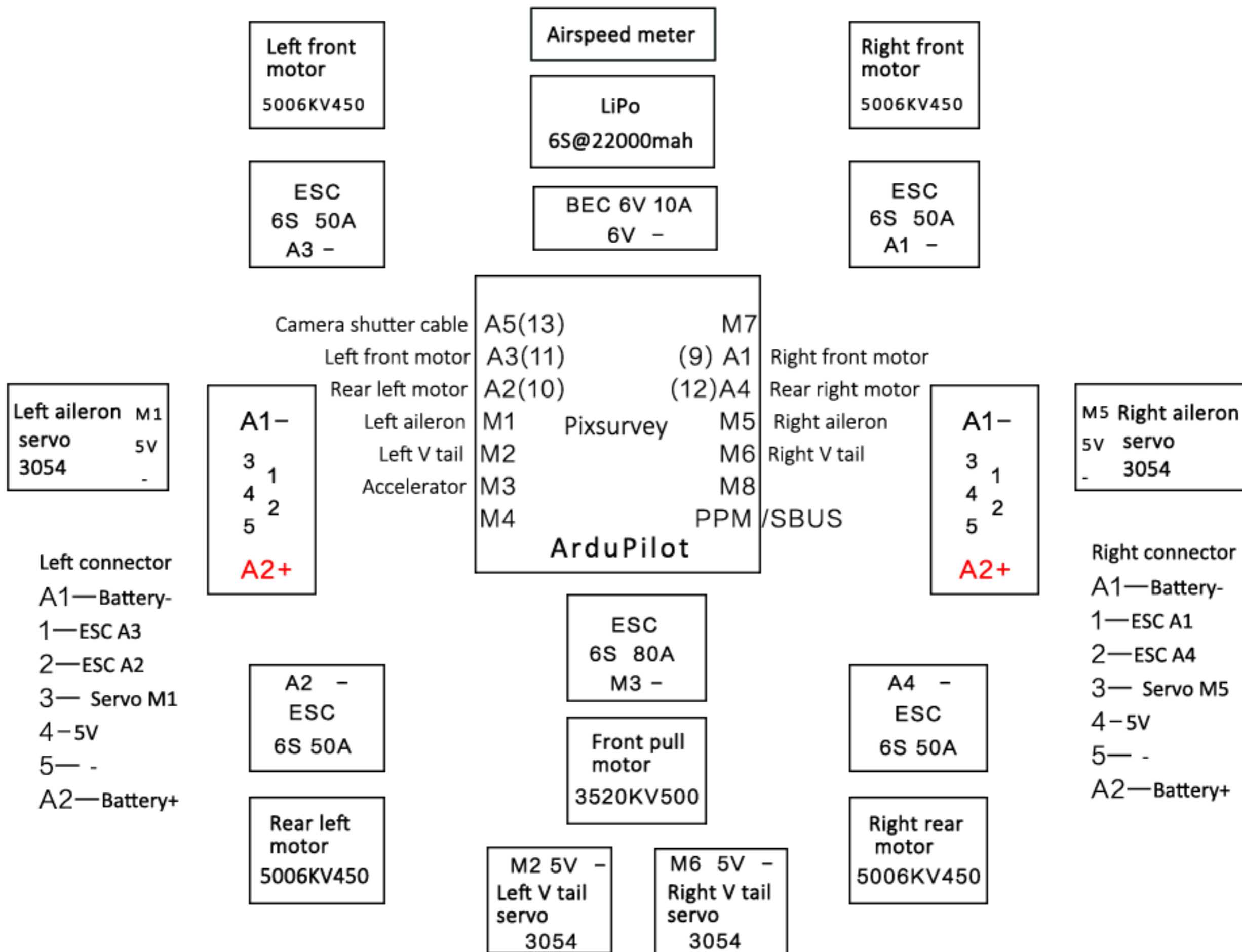

Note: Before powering on, be sure to check the connector line sequence one by one to prevent short circuit.

Configuration List of Spare Parts

Retrograde VTOL parts configuration list

Name	Specification	KIT	PNP
Flying platform	Hero left wing root section	1	1
	Hero left wing tip section	1	1
	Hero right wing root section	1	1
	Hero right wing tip section	1	1
	Hero rotor arm (including fixing parts)	2	2
	Hero rotor motor mount	4	4
	Hero airframe (two noses)	1	1
	Hero airframe accessories	1	1
	Hero V-tail	1	1
	Hero Parts Kit	1	1
	Hero foam packing box	1	1
	Hero carton	1	1
Power system	Cruise 3520 kv500 motor		1
	Cruise 6S 80A Brushless ESC		1
	Cruise propeller APC1510		1
	VTOL motor 5006 kv450		4
	VTOL ESC 6S 50A		4
	VTOL positive and negative carbon fiber propeller 1555		2
	Fixed Wing Servo 3054		4
	Customized 3S-14S UBEC 6V10A		1
	Wing Terminal Board		2
	PNP special wire package		1

Disclaimer

Makeflyeasy aerial survey series products are sensitive items, and the manufacturer does not assume any responsibility for the consequences of direct or indirect consequential accidental damage caused by any reason, and it is prohibited to use it for military purposes.

Please keep the aircraft out of the reach of children, keep the aircraft away from crowds and dangerous objects when flying, and do not operate the aircraft under the condition of drinking, fatigue or poor spirits.

Specifications

Material	EVA	Origin	Mainland China
CN	Sichuan	Recommend Age	14+y