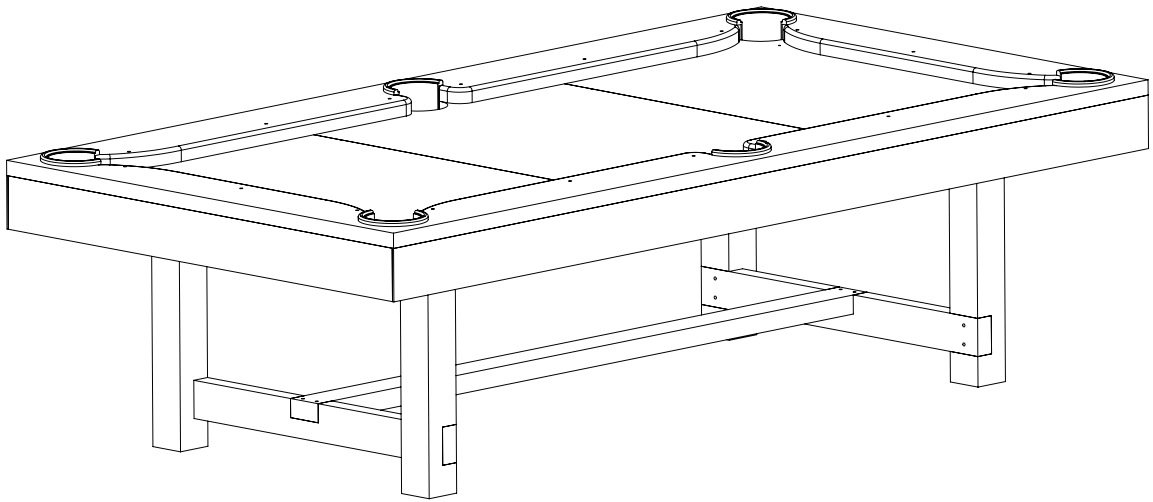
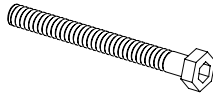
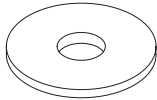

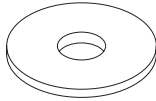
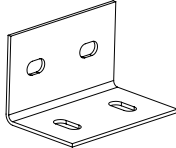

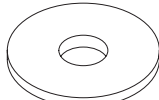
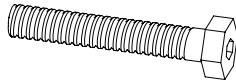
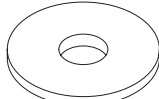




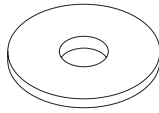

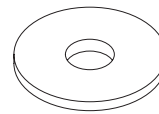

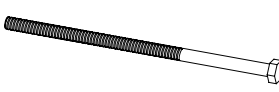
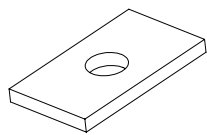
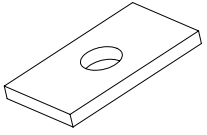

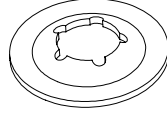
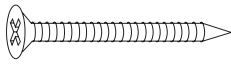
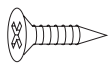
# DAKOTA



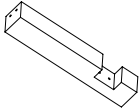
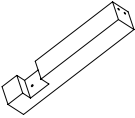
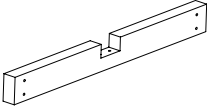
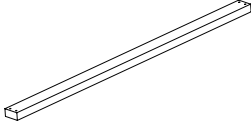
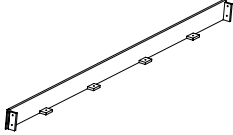
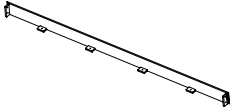
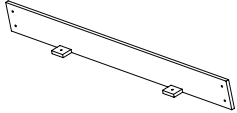
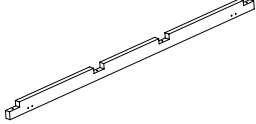
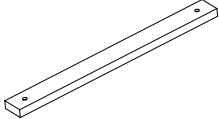
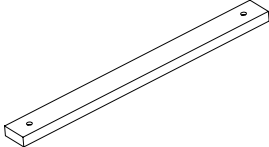
DAKOTA TABLE ASSEMBLY INSTRUCTIONS

## REPLACEMENTPARTSLIST(HARDWARE)

PACKAGE	ITEM#	SAMPLE	DESCRIPTION	QTY.
LEG	H1		HEX HEAD CROSS BOLT 3/8"*3-1/4"	12
	H2		FLAT WASHER 3/8"*28-30mm*2mm"	12
	H20		HEX HEAD CROSS BOLT 3/8"*1-1/2"	8
	H21		FLAT WASHER 3/8"*28-30mm*2mm"	8
	L CONNECTOR		120*(50*50)*3mm	4
BEAM	H3		HEX HEAD CROSS BOLT 5/16" * 1-1/2"	8
	H4		FLAT WASHER 5/16" * 22mm*2mm	8
BEAM/LEG	H5		HEX BOLT 3/8"*3-3/8"	8
	H6		FLAT WASHER 3/8"*28-30mm*2mm	16
	H7		HEX NUT 3/8" I.D.	8

PACKAGE	ITEM#	SAMPLE	DESCRIPTION	QTY.
PANNEL	H8		HEX HEAD CROSS BOLT 5/16" * 1-1/2"	8
	H9		FLAT WASHER 5/16" * 22mm*2mm	8
PANNEL/RAIL CUSHION	H10		HEX HEAD CROSS BOLT 5/16" * 1-1/2"	12
	H11		FLAT WASHER 5/16" * 22mm*2mm	12
RAIL CUSHION	H12		HEX HEAD CROSS BOLT 3/8"*4"	4
	H13		HEX HEAD CROSS BOLT 3/8"*7"	2
	H14		RECTANGULAR WASHER 3/8"*35*20*3mm	6
	H15		RECTANGULAR NUT 3/8"*35*20*3mm	6
SLATE/RAIL	H16		HEX HEAD CROSS BOLT 3/8"*2"	18
	H17		PLUM BLOSSOM WASHER 3/8"*34*2mm	18
SLATE	H18		FLAT HEAD SCREW 11*5*60mm	12
POCKET	H19		FLAT HEAD SCREW 8*3*16mm	12

# REPLACEMENT PARTS LIST

PACKAGE	ITEM#	SAMPLE	DESCRIPTION	QTY.
LEG	1		LEFT LEG	2
	2		RIGHT LEG	2
	3		SHORT LEG BEAM	2
	18		LONG LEG BEAM	1
PANNEL	4		LEFT SIDE APRON	1
	5		RIGHT SIDE APRON	1
	6		END APRON	2
BEAM	7		LONG BEAM	2
	8		END BEAM(SHORT)	2
	18		CENTER BEAM(LONG)	2

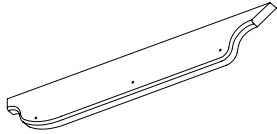
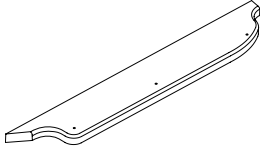
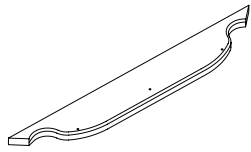

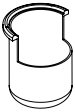
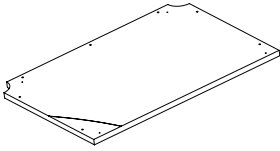
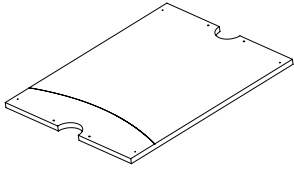
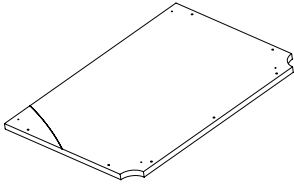
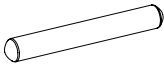
PACKAGE	ITEM#	SAMPLE	DESCRIPTION	QTY.
RAIL CUSHION	9		TOP TAIL LEFT SIDE	2
	10		TOP TAIL RIGHT SIDE	2
	11		TOP RAIL END	2
POCKET	12		CORNER POCKET	4
	13		SIDE POCKET	2
SLATE	14		SLATE(LEFT)	1
	15		SLATE(CENTER)	1
	16		SLATE(RIGHT)	1
	17		WOOD JOINT	4

FIG.1

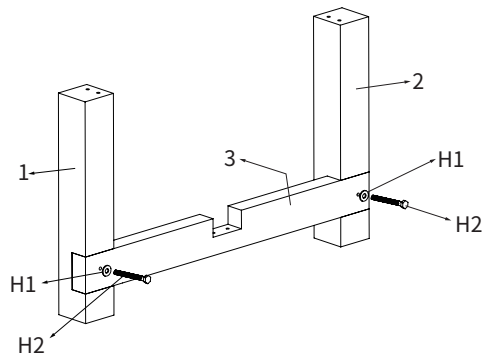


FIG.2

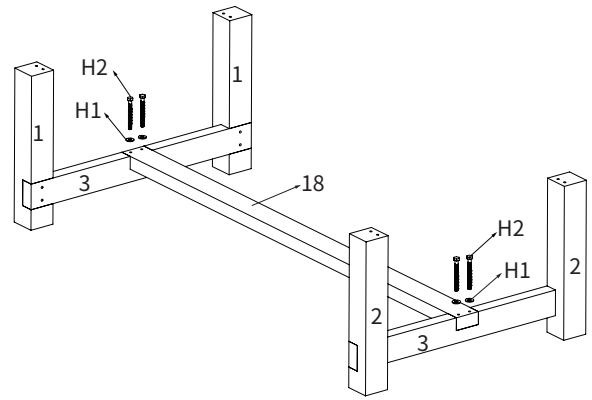


FIG.3

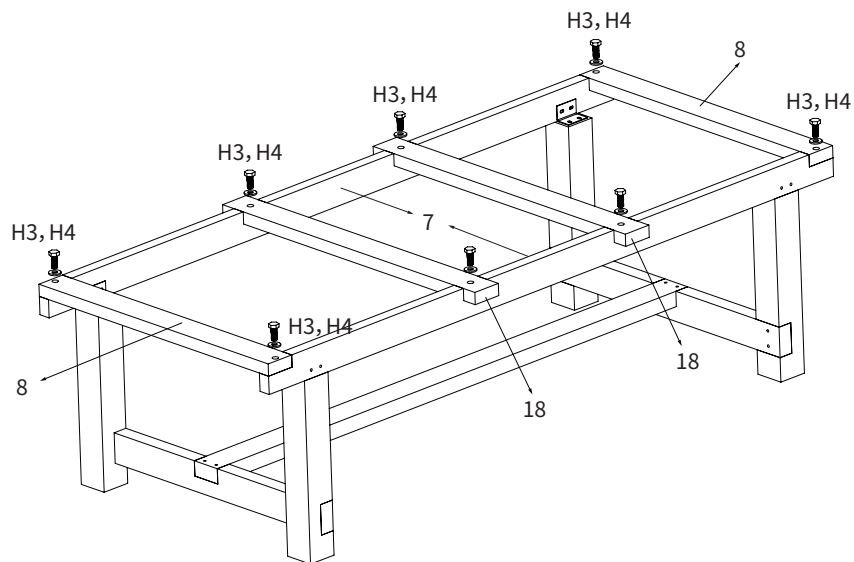
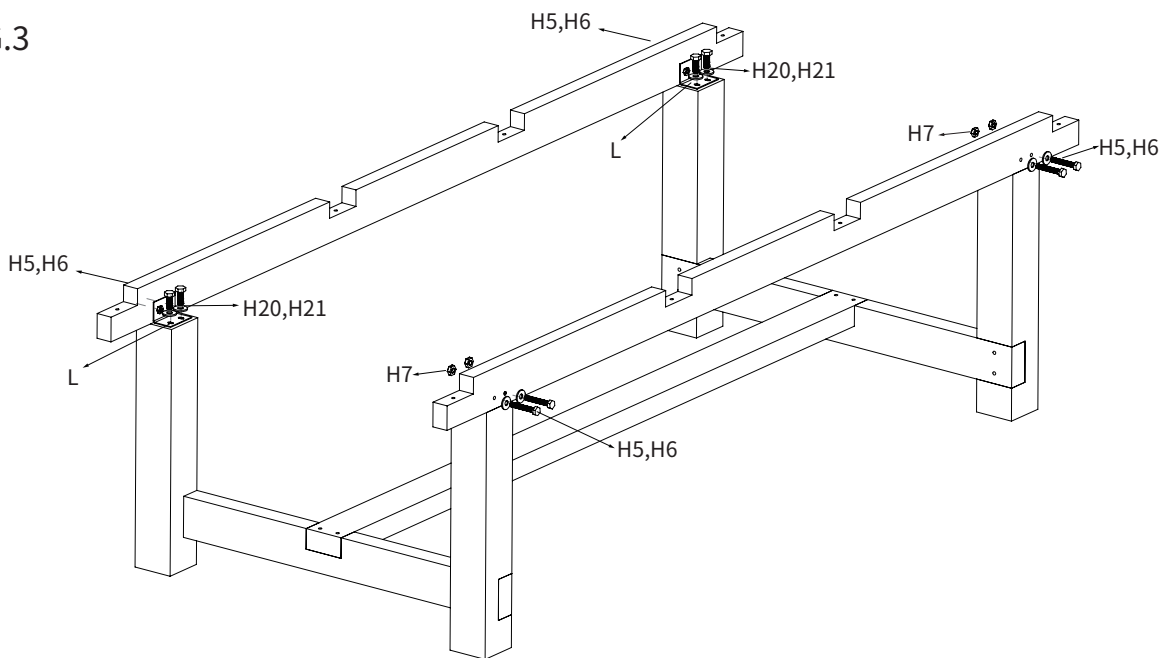


FIG.4

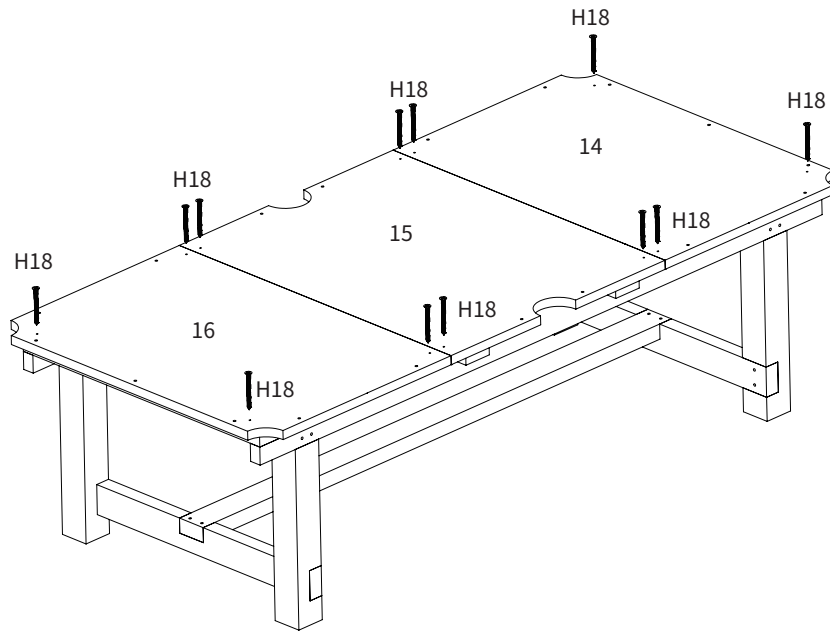


FIG.5

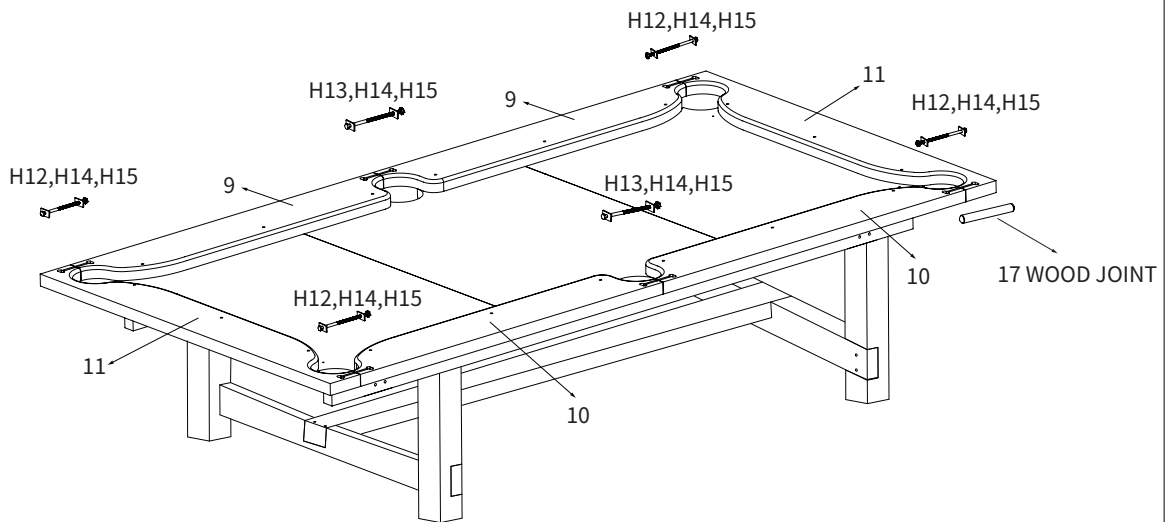


FIG.6

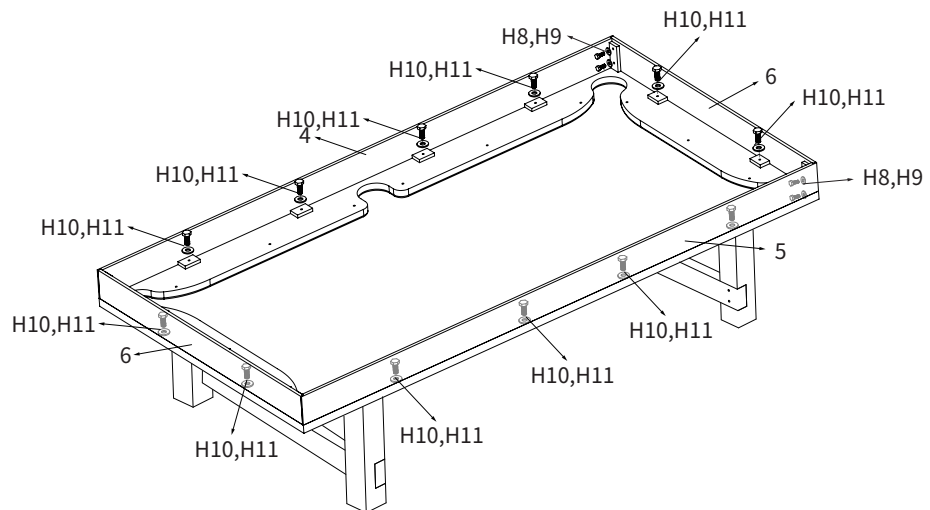


FIG.7

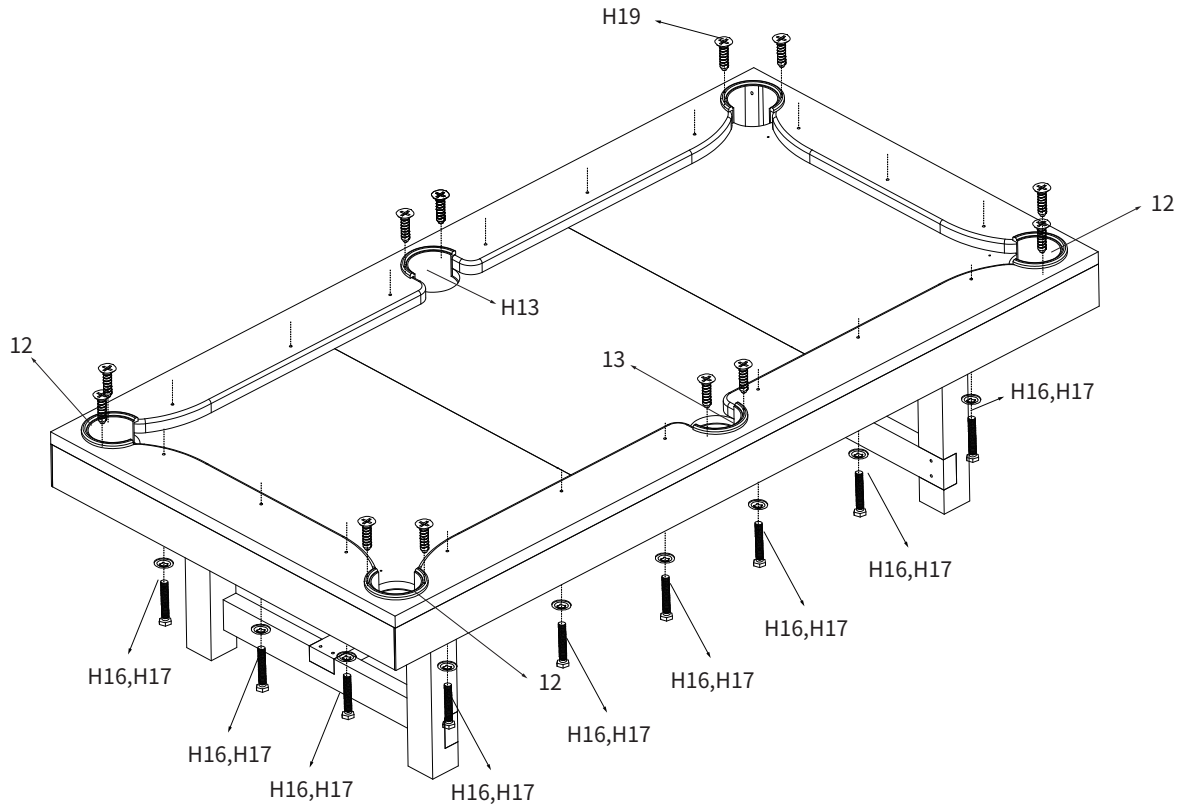
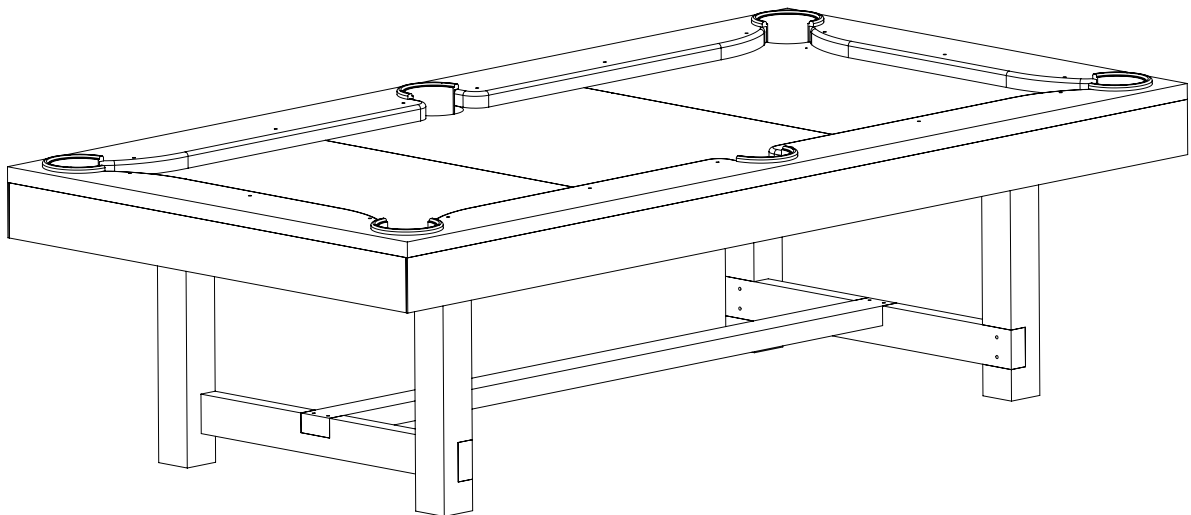


FIG.8



Finish