

# SUNSTRIKE™

## Solar Up & Down Wall Pack



Sunstrike Up and Down spotlight offer dual illumination with one side emitting light upward and the other downward. The distinctive design of up and down spotlights enhances outdoor lighting by providing versatile illumination in both directions, adding an aesthetic touch to various application. Hassle free installation as no electrical wiring is needed. Mount on walls, fences or any surface to create stunning and versatile lighting effects outdoors.

- High Capacity power lithium battery with a lifespan of over 2000 cycles.
- Built-in light sensors for automatic on/off.
- First 5 hours at 100% brightness and 20% brightness until dawn.
- Antitheft screws with tooling is included.
- Die Cast Aluminum with C4H Marine corrosion resistance.
- Color Dark Grey fixture.
- Fast Automatic Error Reporting in bluetooth app.
- IP66 rated with Impact rating IK10.



# SUNSTRIKE™

## Solar Up & Down Wall Pack

### SPECIFICATIONS

Model #	SKU #	Power	PV Type	Solar Panel	Lithium Battery	Lumens	CCT	Sensor	Beam Angle	IP Rating
AVS-STR-300 4000K	790110	1W	Mono	4.32V	5AH-3.7V	150x2 LM	4000K	Ray Sensor	120°	IP66

### LUMINOUS FLUX

150 LUMENS

Solar Panel	◀	
Voltage / Power		4.32V / 1W
Li-ion Battery	◀	
Capacity / Voltage / Power		5AH / 3.7V/ 18.5W
Charging / Discharging Tem		0~45°C/ -20~60°C
LED	◀	
Luminous Flux		150 x 2 LM
LED Package / Quantity		Osram 3030 / 11Pc
Color Temperature(CCT)		4000K
PERFORMANCE	◀	
Rainy Days Back		>10 Days
Default Lighting Mode		100%5H+20% Till Dawn
Networking Type		Bluebooth Mesh
Core Technology		ALS 2.5 / TCS 3.0
IP/IK/Anti-Corrosion		IP66 / IK10 / C4H
Button Switch		ON/OFF: Long Press 1.5s; Reset: Long press 6S
DIMENSIONS	◀	
Carton Size (Inner Box)		7.55 x 5.66 x 6.57
Carton Size (Outer Box)		23.26 x 17.59 x 20.31
Net Weight		/
Gross weight		/
QTY Per Outer Box		27 Pcs



# SUNSTRIKE™

## Solar Up & Down Wall Pack

### DIMENSIONS

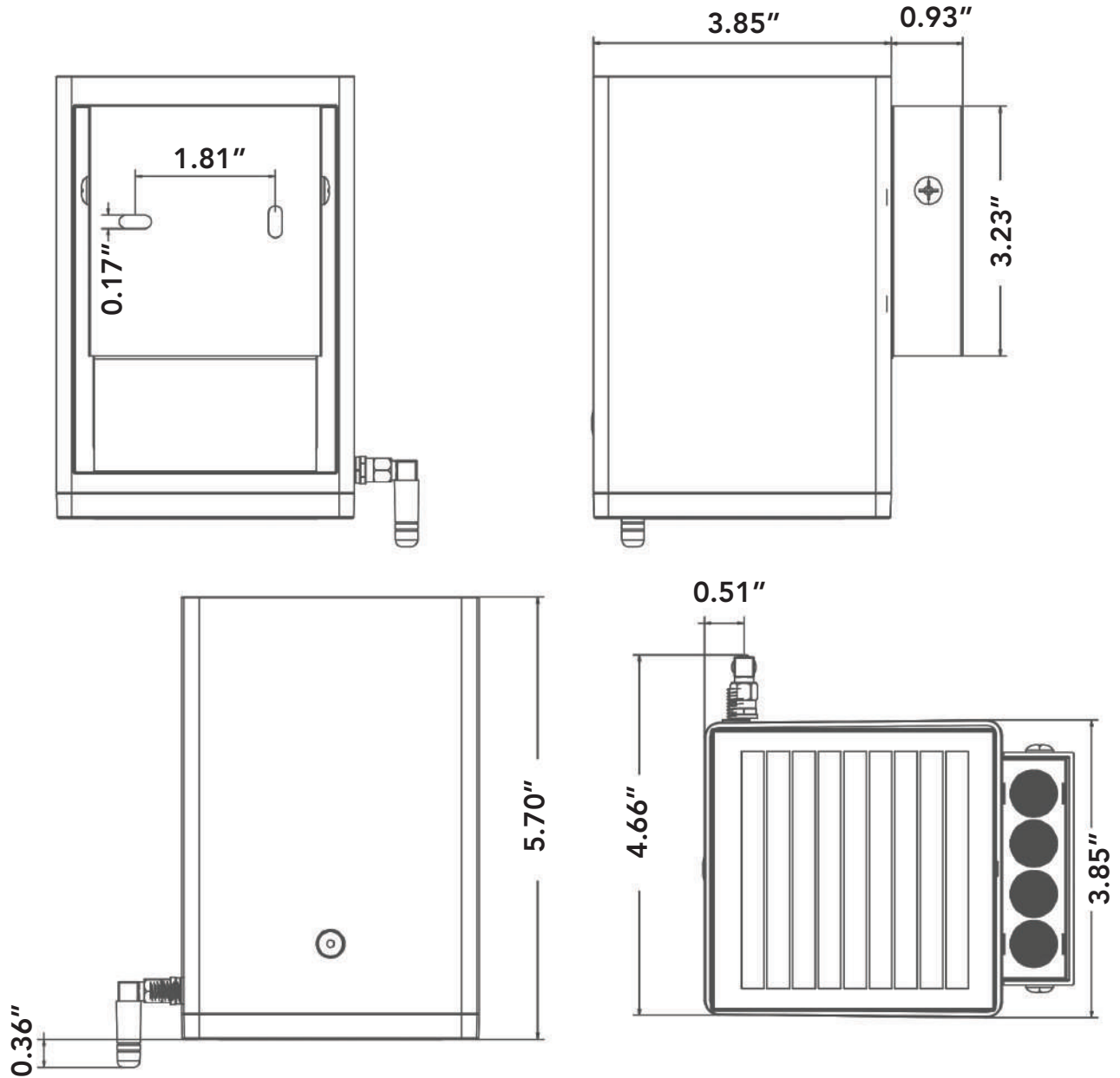

# SUNSTRIKE™

## Solar Up & Down Wall Pack

### MORE DETAILS

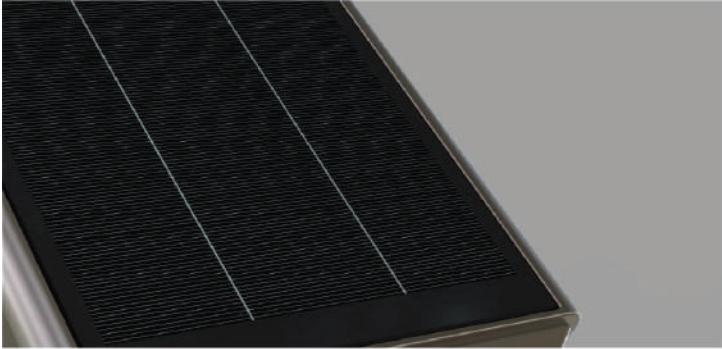

**Monocrystalline**  
**>21%**

**Bracket**

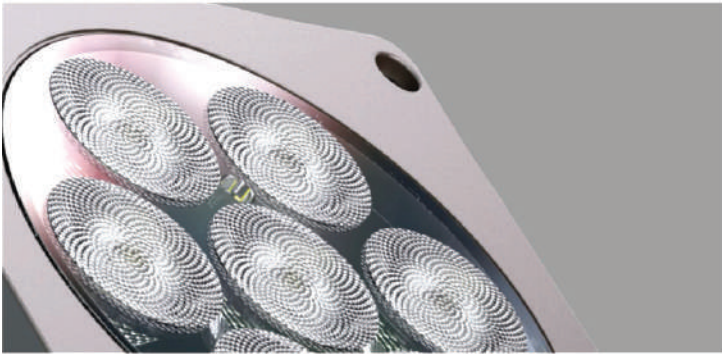
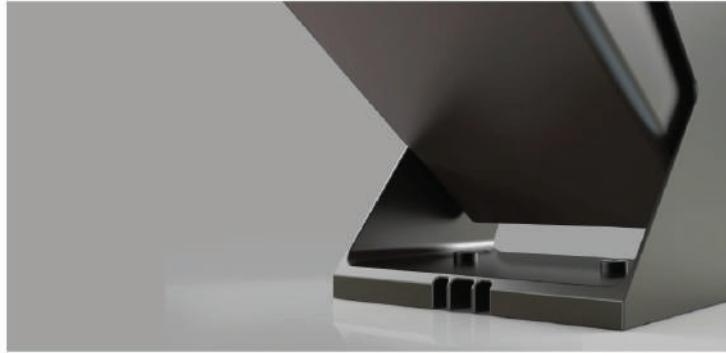

**Durable**  
**High-Quality**  
**PC Material**

**Switch**

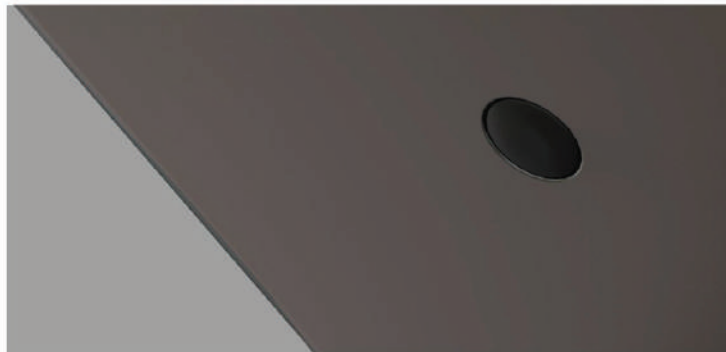

# SUNSTRIKE™

## Solar Up & Down Wall Pack

### SIMULATED DIAGRAM

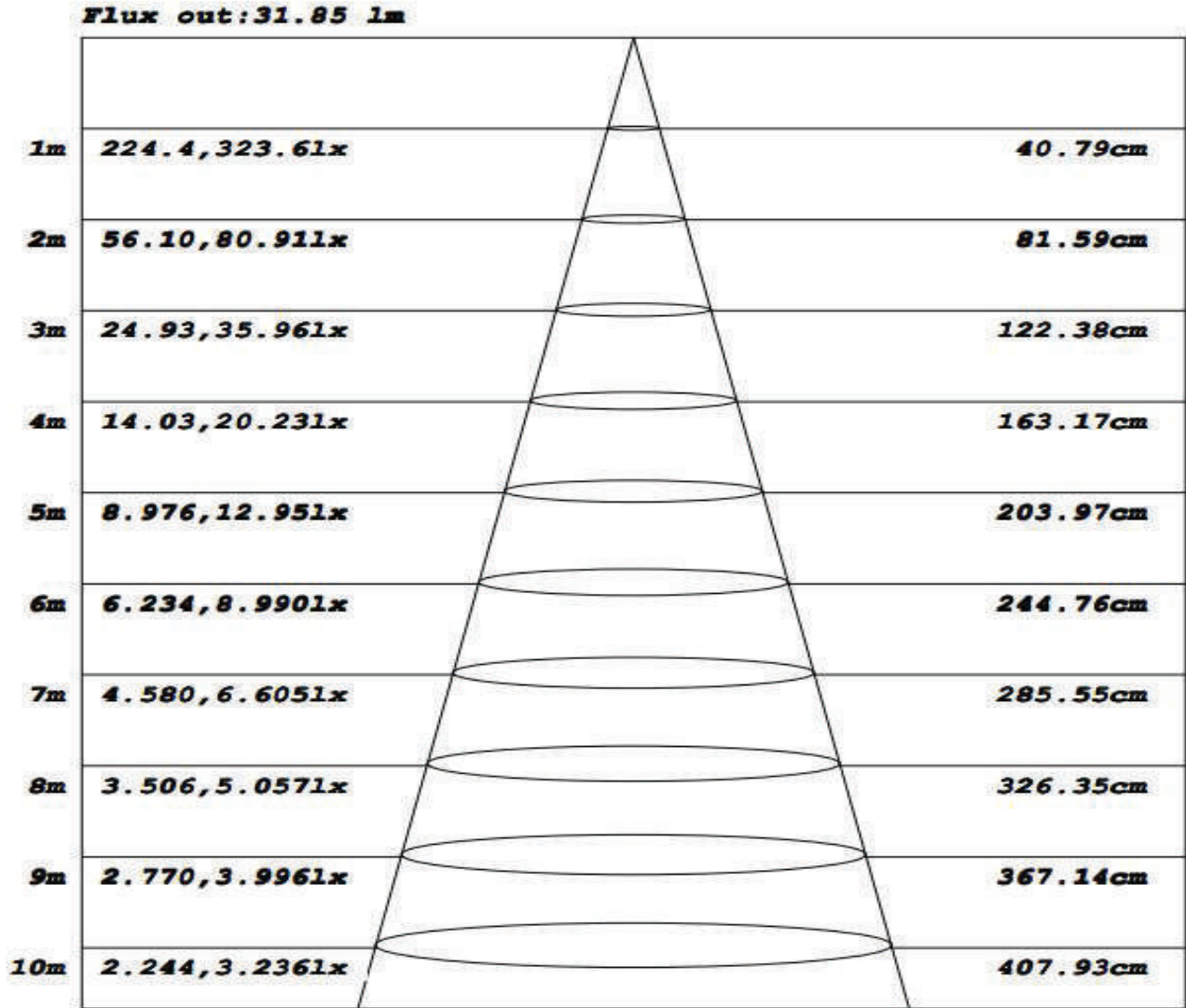

Note: The Curves indicate the illuminated area and the average illumination when the luminaire is at different distance.





# SUNSTRIKE™

## Solar Up & Down Wall Pack

### LUMINANCE DISTRIBUTION

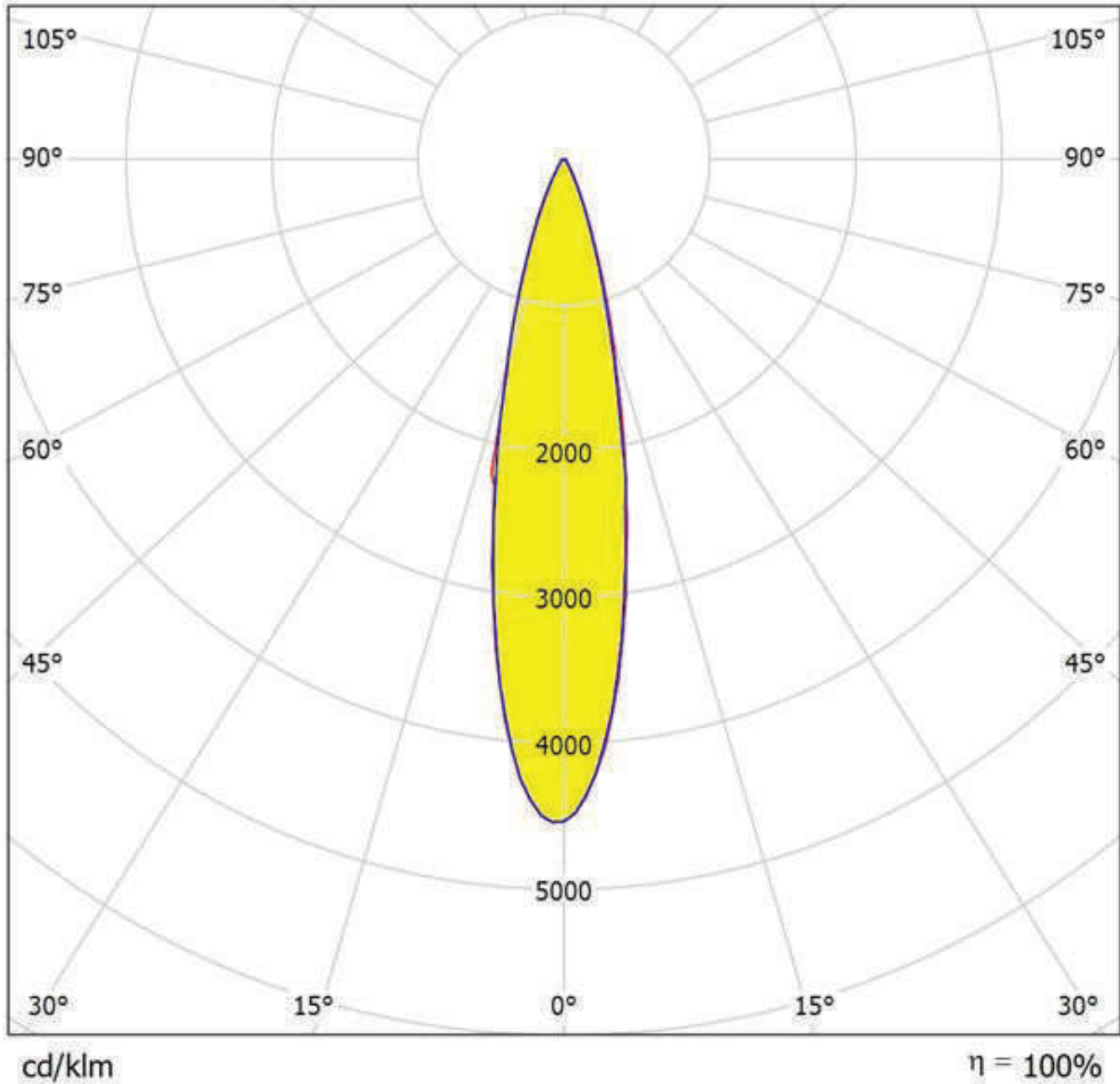

SOLAR UP & DOWN WALL PACK



# SUNSTRIKE™

## Solar Up & Down Wall Pack

### INSTALLATION

-20°C-60°C  
 With Heating Version(H)  
 -20°C-60°C

0°C-60°C  
 With Heating Version(H)  
 0°C-60°C

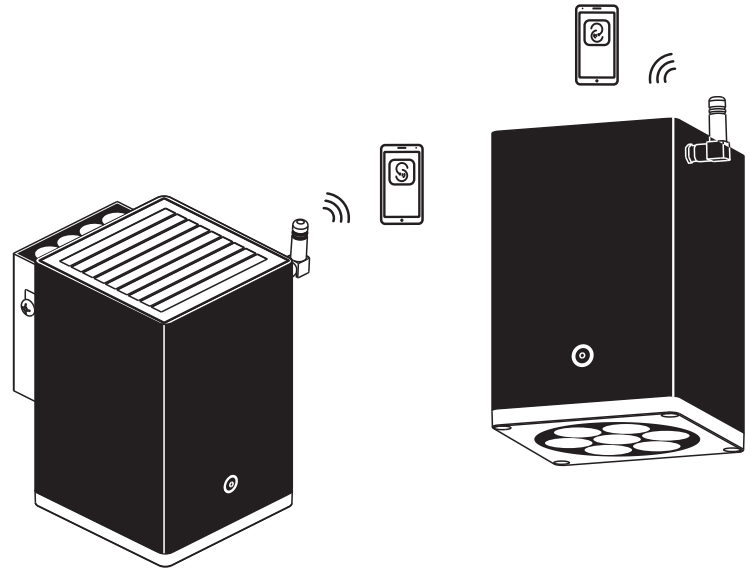

### KEY PARTS OF PRODUCT

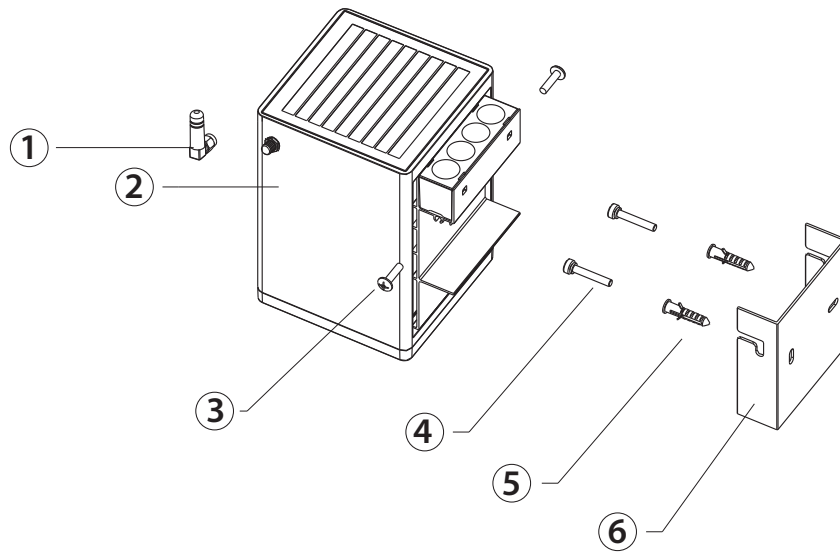

① Antenna

② Lamp Body

③ M4 Screw

④ TA4\* 25 Screw

⑤ Plastic Expansion  
Screw Pillars

⑥ Wall Mounted  
Bracket



# SUNSTRIKE™

## Solar Up & Down Wall Pack

### INSTALLATION

#### HOW TO INSTALL THE LIGHT?

##### Installation Diagram

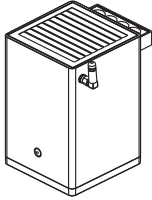

1. Please install antenna.

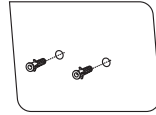

2. Install the plastic expansion screw pillars.



3. Installation Bracket.

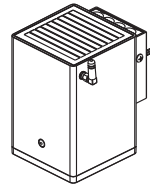

4. Please install the lamp and keep the antenna always pointing straight up, then press the button to turn on the lamp.

#### THE PRODUCT OPERATION INSTRUCTIONS

##### SWITCH

Press the button for 1.5 seconds(on/off)

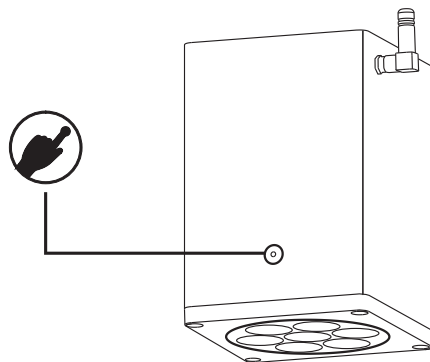

##### FEATURES

Solar panel: Mono-crystalline, Tempered glass laminated.

Charging battery: Lithium battery

Material: Aluminum Alloy +PC





# SUNSTRIKE™

## Solar Up & Down Wall Pack

### INSTALLATION

#### BLUETOOTH MESH



Please Scan and download App

#### SPECIAL NOTE

- Do not install the lamp against the sun, under the shadow or buildings which height above the lamp. Otherwise, it maybe need a longer charging time.
- Do not use the non-standard accessories to install the lamp.
- Setting a suitable lighting model according to local sunlight.
- Please charge the product every 3 months to ensure the activity of the lithium battery.
- If you storage the product over one year, please do fully charge and discharge inspection and make sure the battery is in good condition Otherwise, it is forbidden to use!

#### WARNING

1. Keep the device away from fire and oil to avoid any fire or explosion.
2. No one except professional technicians should attempt to disassemble the light in order to avoid damaging the light.
3. It is strictly forbidden to disassemble the battery for personal use.
4. If the lamp doesn't get charge for one week, the battery maybe out of power, you have to charge it under bright sunlight.
5. In order to ensure that the lamp works in an ideal state for a long time, please clean the solar panel regularly according to the local dust conditions, our suggestion is one time at least half a year.
6. long-term static storage the product over one year will cause the inside battery damage or even leakage, If the battery is leaking, it will cause the battery to spontaneously ignite.



# SUNSTRIKE™

## Solar Up & Down Wall Pack

### PACKAGE DETAILS

**PRODUCT LIST**  
**BRACKET : 1 PC**  
**INSTRUCTIONS : 1 PC**  
**SCREW : 1 SET**

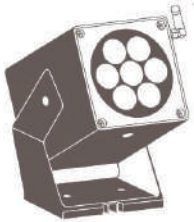

● **PRODUCT LIST**

STEP 1

**INNER BOX**  
**1 PC / 1 BOX**



● **INNER BOX**

STEP 2

**LAYERS TOTAL :3,**  
**EACH LAYER 9PCS**



● **LAYER NUMBER**

STEP 3

**OUTER CARTON**  
**27BOXES / CTN**



● **CARTON**

STEP 4

SOLAR UP & DOWN WALL PACK



# SUNSTRIKE™

## Solar Up & Down Wall Pack

### WIDE APPLICATIONS





# SUNSTRIKE™

## Solar Up & Down Wall Pack

WIDE APPLICATIONS



SOLAR UP & DOWN WALL PACK

5 Year  
Limited  
Warranty

BEYOND  
SOLAR



C4H

# SUNSTRIKE™

## Solar Up & Down Wall Pack

### WIDE APPLICATIONS

