



AS35FP Steam Humidifier

Installation and Maintenance Instructions



TABLE OF CONTENTS

SAFETY CAUTIONS	2	MODEL A65 HUMIDIFIER CONTROL INSTALLATION	13
MATERIALS LIST	2	Determine Location for Control	13
PRINCIPLES & SEQUENCE OF OPERATION	3	Model A65 Wiring	14
SPECIFICATIONS & DIMENSIONS	3	START-UP PROCEDURE	15
Water Quality	4	OPERATING MODES	16
INSTALLATION INSTRUCTIONS	6	End of Season/Period of Inactivity Shut-down	16
Location	6	SHUT DOWN PROCEDURE	17
Mount Housing	7	DISPLAY PANEL	17
Hose Connections and Steam Manifold Installation	8	MAINTENANCE	18
Grille Installation	8	TROUBLESHOOTING	20
Humidifier Location	9	TABLE 3 – Humidifier Troubleshooting Guide	20
Prepare Humidifier for Mounting	9	TABLE 4 – Fan Pack Troubleshooting Guide	22
Install Fan Pack	9	REPLACEMENT PARTS	23
Mount Humidifier	9	MODEL A65 HUMIDIFIER CONTROL SPECIFICATIONS	24
Install Steam Hose	9	LIMITED WARRANTY	24
Supply Water	10		
Drain Line	10		
Electrical Power Wiring & Shut-off Switch	10		

READ AND SAVE THESE INSTRUCTIONS

SAFETY CAUTIONS

CAUTION

ATTENTION INSTALLER

Read this manual before installing. This product must be installed by qualified HVAC and electrical contractors and in compliance with local, state, federal, and governing codes. Improper installation can cause property damage, severe personal injury, or death as a result of electric shock, burns, or fire.

Read all cautions and instructions.

Read this manual before performing service or maintenance procedures on any part of the system. Failure to follow all cautions and instructions could produce the hazardous situations described, resulting in property damage, personal injury, or death.

Failure to follow the instructions in this manual can cause moisture to accumulate, which can cause damage to structure and furnishings.

DISCONNECT ELECTRICAL POWER

Disconnect electrical power before installing supply wiring or performing service or maintenance procedures on any part of the humidification system. Failure to disconnect electrical power could result in fire, electrical shock, and other hazardous conditions. These hazardous conditions could cause property damage, personal injury, or death.

Contact with energized circuits can cause property damage, severe personal injury, or death as a result of electrical shock or fire. Do not remove access panels unless electrical power is disconnected.

Follow the shutdown procedure in this manual before performing service or maintenance procedures on any part of the system.

ELECTRICAL SHOCK HAZARD

If the humidifier starts up responding to a call for humidity during maintenance, severe injury or death from electrical shock could occur. Follow the procedures in this manual before performing service or maintenance procedures on this humidifier.

EXCESSIVE SUPPLY WATER PRESSURE

Supply water pressure greater than 120 psi may cause the humidifier to overflow.

HOT SURFACES AND HOT WATER

This steam humidification system has extremely hot surfaces. Water in steam canister, steam pipes, and dispersion tube can be as hot as 212°F (100°C). Discharged steam is not visible. Contact with hot surfaces, discharged hot water, or air into which steam has been discharged can cause severe personal injury. To avoid severe burns, follow procedures in this manual when performing service or maintenance procedures on any part of the system.

MATERIALS LIST

MODEL AS35FP

MATERIALS FURNISHED

- Humidifier
- Model A65 Humidifier Control
- Steam hose (6 feet)
- 7/8" I.D. drain tubing (10 feet)
- Hose clamps
- Saddle valve
- Mounting screws
- Fan Pack
- 2 housing mounting screws
- 4 grill mounting screws
- 2 serrated nuts for mounting the Steam Humidifier
- 1 stainless steel 40° elbow

NOT FURNISHED

- Main power disconnect switch
- Wiring
- 1/4" O.D. supply water tubing
- Boards for mounting (if required)

PRINCIPLES & SEQUENCE OF OPERATION

The Anden® Steam Humidifier delivers humidity in the form of steam to the conditioned space via the Fan Pack. The humidifier generates steam by energizing two electrodes that extend into a canister of water. Current flowing between the electrodes causes the water to boil, creating steam. Water is introduced to the humidifier through a fill valve to a fill cup located in the top of the cabinet. The fill cup serves as an overflow reservoir and provides an air gap between the humidifier and water source. The steam canister is filled from the bottom. The canister is seated in a drain cup assembly which includes a drain valve. The drain and fill valves work together to maintain water level in the canister to deliver the rated steam capacity based on the electrical conductivity of the water and to temper drain water. See **FIGURE 1** for representation of fill and drain system and canister.

Humidity is distributed directly into the room via the Fan Pack. When the humidistat detects RH below the set point, the humidifier energizes the electrodes to provide steam via the steam manifold at the bottom of the Fan Pack. Steam is dispersed by the fan located behind the grille above the steam manifold. The fan will operate for two minutes after the call for humidity ends, to disperse any residual steam.

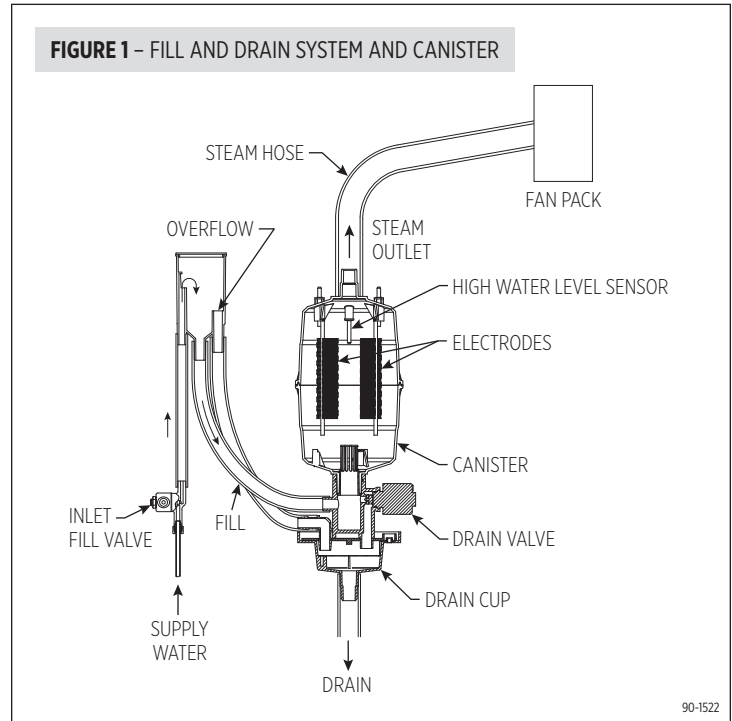

SPECIFICATIONS & DIMENSIONS

This humidifier is able to produce steam at various capacities depending on the voltage and current applied. The unit can be wired to use an input voltage of 120, 208 or 240 Volts and input amperage can be set to 11.5 or 16.0 amps by changing a dip switch on the control circuit board (see the **ELECTRICAL POWER WIRING & SHUT OFF SWITCH** section on page 10). Configure the unit appropriately for the application. For sizing recommendations call Anden Customer Service at 1-800-972-3710.

Shipping Weight: 39 lbs

Humidifier Operating Weight: 23 lbs*

*As minerals precipitate, unit weight can increase to approximately 30 lbs.

WATER QUALITY

Minerals that are naturally found in water contribute to water's electrical conductivity; water conductivity is measured in Electrical Conductivity Units (EC). Mineral content, also described as "water hardness" is usually measured in grains per gallon. Variation is found among water samples but generally the higher the mineral content, the higher the conductivity.

The Steam Humidifier is designed to operate on water with conductivity between 100 and 1,250 EC. This correlates loosely with water hardness between 3 and 36 grains/gallon. Water that is considered "hard" and softened water work well in the Steam Humidifier. The humidifier makes steam when plumbed to low-conductivity water but it takes longer to reach nominal current.

Two canisters are available for use with the Steam Humidifier. The Model AS80 canister is used in most installations and is optimized for "hard" and softened water. The Model AS80 typically works best when the Steam Humidifier is installed at 208 or 240 VAC. If the Steam Humidifier has a yellow Steam light in the first two weeks of running with a new canister, the Steam Humidifier is taking a long time to reach its nominal current; changing to the Model AS80LC canister will prevent this from happening in the future.

The Model AS80LC canister is optimized for use in areas where the water conductivity is less than 300 EC or when the Steam Humidifier is installed at 120VAC. The Model AS80LC should not be used with softened water. If the Steam Humidifier is draining too frequently, the water conductivity is too high; changing to the Model AS80 canister will reduce the drain frequency.

As water in the canister boils and turns into steam, minerals are left behind. Minerals remaining in solution increase the conductivity of the water. Minerals also deposit onto the submerged portions of the electrodes rendering those areas ineffective. As this occurs, the level of water in the canister rises to expose uncoated electrode surface.

There are benefits and trade-offs to consider when the application allows a choice between hard and softened water:

Hard water: The benefit of hard water is less frequent draining and filling than with soft water, which results in better energy and water efficiency and more consistent steam output. However, canister replacement could be more frequent with hard water, because mineral deposits coat the electrodes. The harder the water, the more frequent the need for a new canister.

Softened water: The benefit of softened water is longer canister life (depending on water chemistry) than with hard water, because softened water does not coat the electrodes nearly as much as hard water. However, softened water ions stay in solution to much higher concentrations than hard water ions. This requires more frequent draining and filling, which results in lower energy efficiency, higher water consumption and less consistent steam output.

TABLE 1 – WATER QUALITY GUIDELINES

Electrical Conductivity Unit (EC)	Grains/Gal	Hardness	Recommended Canister by Voltage		
			120VAC	208VAC	240VAC
75-100	0-3	Naturally Soft	Installation Not Recommended	AS80LC	AS80LC
100-300	3-9	Naturally Soft	AS80LC	AS80LC	AS80LC
300-500	9-15	Slightly Hard	AS80LC	AS80	AS80
500-650	15-20	Moderately Hard	AS80LC	AS80	AS80
650-850	20-25	Hard	AS80LC	AS80	AS80
850-1250	25-36	Very Hard	AS80LC	AS80	AS80
above 1250	above 36	Extremely Hard	Installation Not Recommended		
		Softened	AS80	AS80	AS80

FIGURE 2 - HUMIDIFIER DIMENSIONS (INCHES)

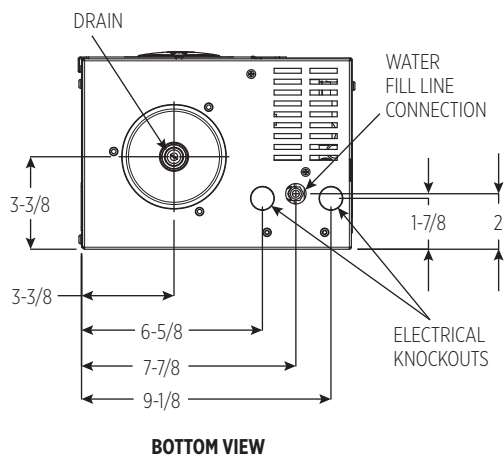
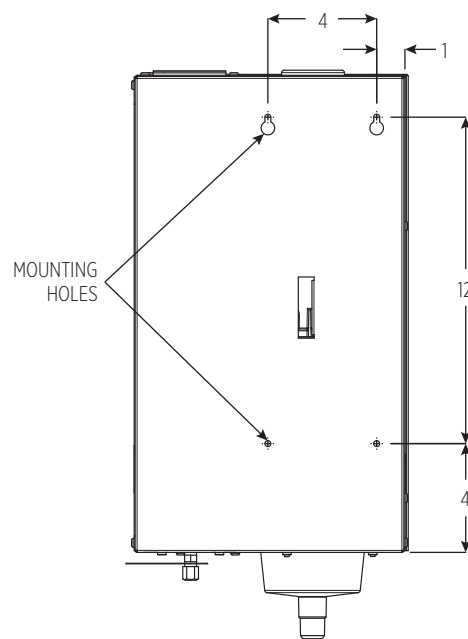
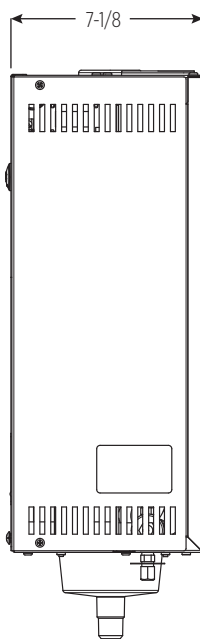
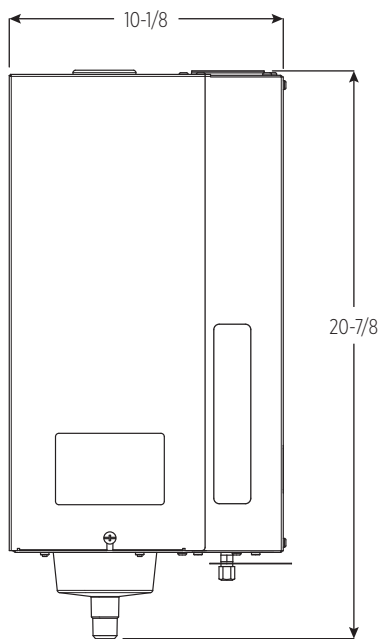
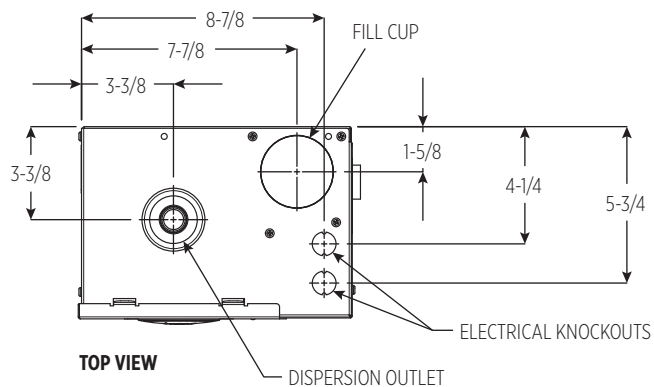
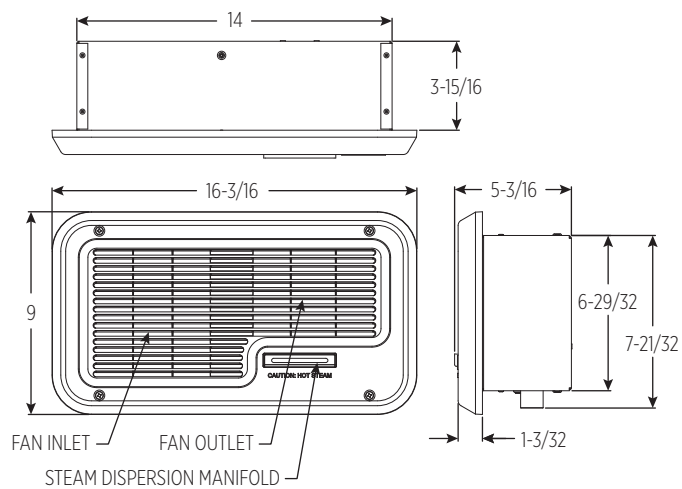

FIGURE 3 - FAN PACK DIMENSIONS (INCHES)



INSTALLATION INSTRUCTIONS

LOCATION

The Fan Pack must be located near the Steam Humidifier to minimize the length of the steam hose. If the Fan Pack is mounted directly above the humidifier, at least 6" is required for the steam hose to make the bend. See **FIGURES 4-6** for installation options.

Six feet of steam hose is provided with the Steam Humidifier. For installations that require longer runs, a combination of the steam hose and insulated copper pipe can be used. See **FIGURE 6**. When using more than 24" of steam hose or 36" of insulated copper pipe, install a Drain Tee and Trap (#4028) to help control condensate and reduce gurgling. See **FIGURE 6**.

Due to condensation inside the hose or pipe, the output of the Fan Pack depends on the length of the steam hose or pipe connecting it to the Steam Humidifier.

To prevent condensation on surfaces and furnishings, install the Fan Pack so the steam being discharged has enough room to be absorbed into the air before encountering surfaces.

FIGURE 4 - EXTERNAL FAN PACK INSTALLATION

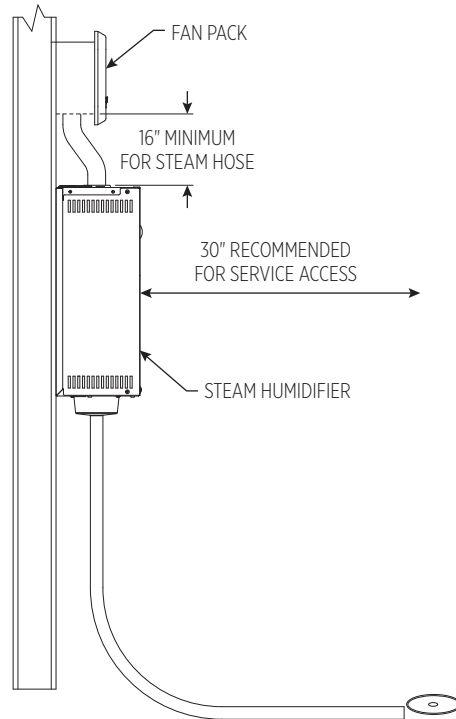

90-2347

FIGURE 5 - SIDE VIEW

TYPICAL INSTALLATION

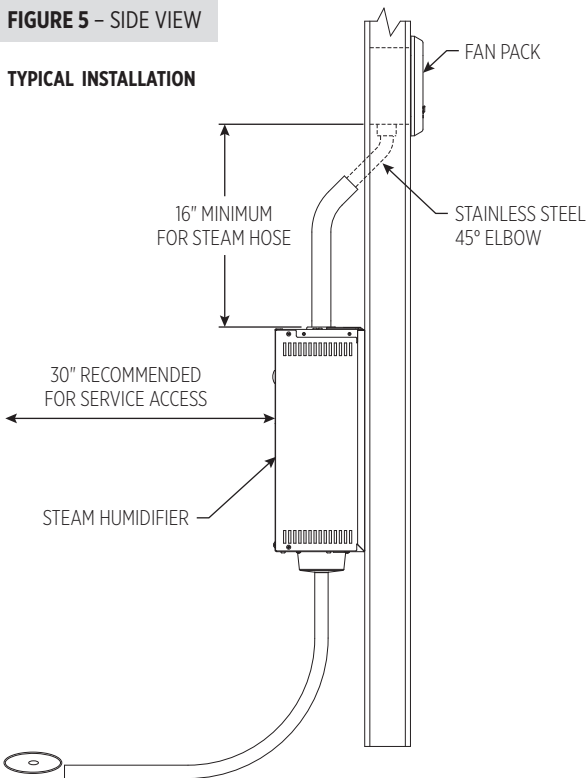

90-2194

FIGURE 6

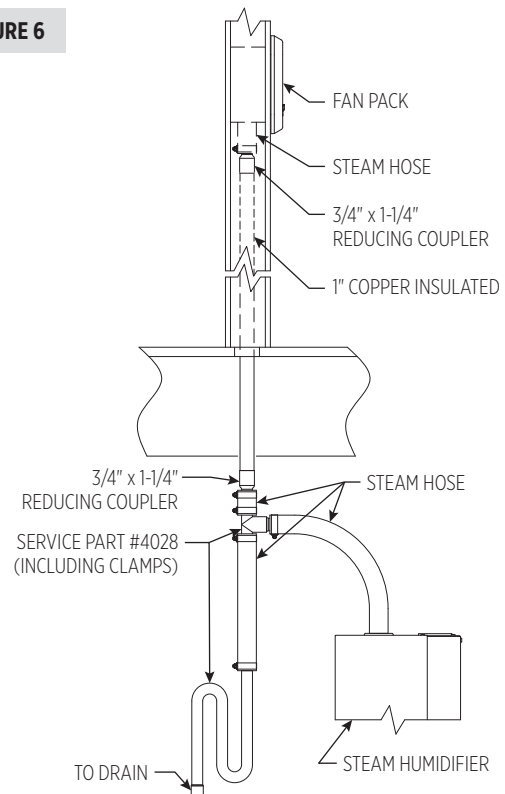

90-2022

The following guidelines are for a 240V installation in which the unit discharges into a space with 70°F air temperature and 40% RH.

- Allow 5 feet of unobstructed space directly in front of the grille.
- Allow 2 feet on either side of the grille.
- Allow 1-1/2 feet above the grille.

See **FIGURE 7**.

If the room temperature is less than 70°F, allow an additional 6" to each distance for every two degree drop in temperature.

If the RH set point is higher than 45%, allow an additional foot of space between the grille and any obstruction or surface.

Warmer room air temperature and RH below 35% will reduce the amount of unobstructed space required to absorb discharged steam, but the distances provided are recommended minimums.

DISTANCE FROM HUMIDIFIER TO FAN PACK

The capacity of the humidifier is reduced by the length of the steam hose or pipe due to condensation. The maximum recommended length of steam hose is 6 feet. Use hard pipe insulated with 1" thick insulation rated for 212°F or higher for lengths greater than 6 feet. If 6-foot steam hose does not reach from humidifier to dispersion tube, splice in 1" copper pipe using 3/4" x 1" reducing couplings as shown in **FIGURE 6**.

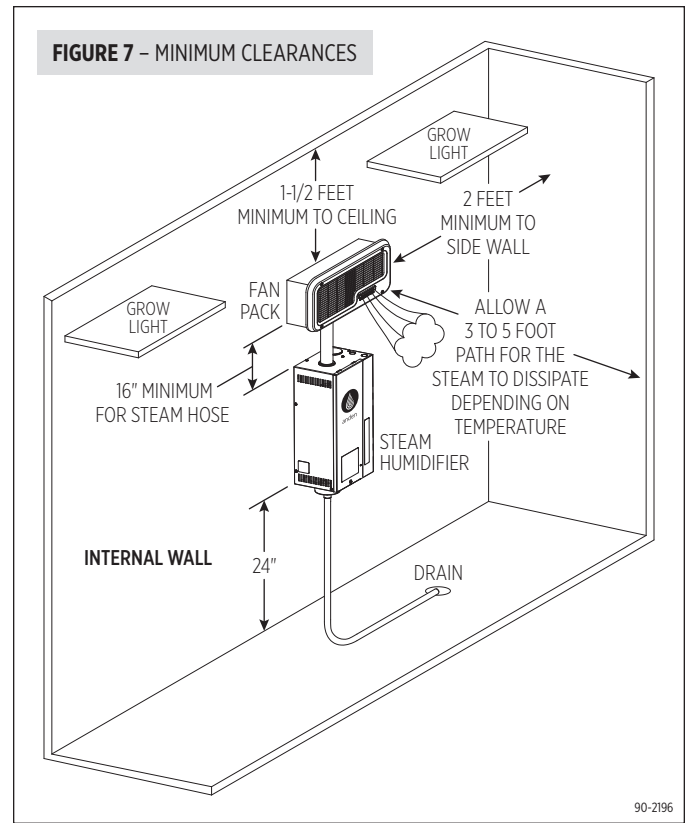

MOUNT HOUSING

The Fan Pack installs between the studs of a standard 16" on-center internal wall. To ensure proper operation, the Fan Pack must be mounted level. Use the four 1-1/2" mounting screws provided to attach the housing to the wall studs. See **FIGURE 8**.

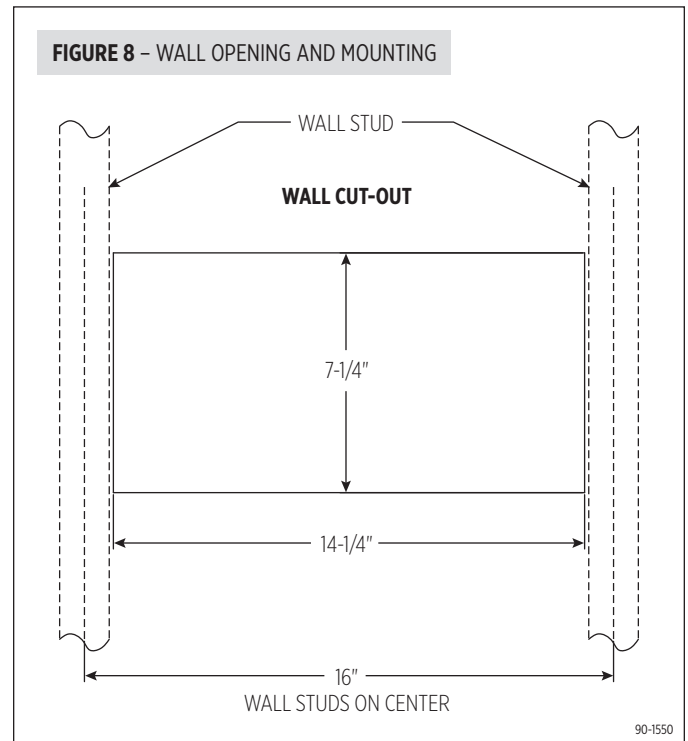

HOSE CONNECTIONS AND STEAM MANIFOLD INSTALLATION

Connect the steam hose (provided with the Steam Humidifier) to the Fan Pack Steam Manifold and use hose clamp (provided with the Steam Humidifier) to secure. Then install the steam manifold into the Fan Pack cabinet by feeding the steam hose back into the wall cavity, and secure the manifold with the two serrated nuts (included). See **FIGURE 9**. A 45° stainless steel elbow is provided for installations with the Steam Humidifier mounted on the wall behind the Fan Pack. See **FIGURE 5**. If more than 6 feet is required, use insulated hard pipe as shown in **FIGURE 6**. See the Steam Humidifier manual for the effect on capacity.

GRILLE INSTALLATION

Use the four 5/8" screws to attach the Fan Pack grille to the fan housing and drywall. See **FIGURE 10**. If painting the grille is desired, see a painting professional for acceptable paint products for high temperature (212°F), high humidity environments and polycarbonate.

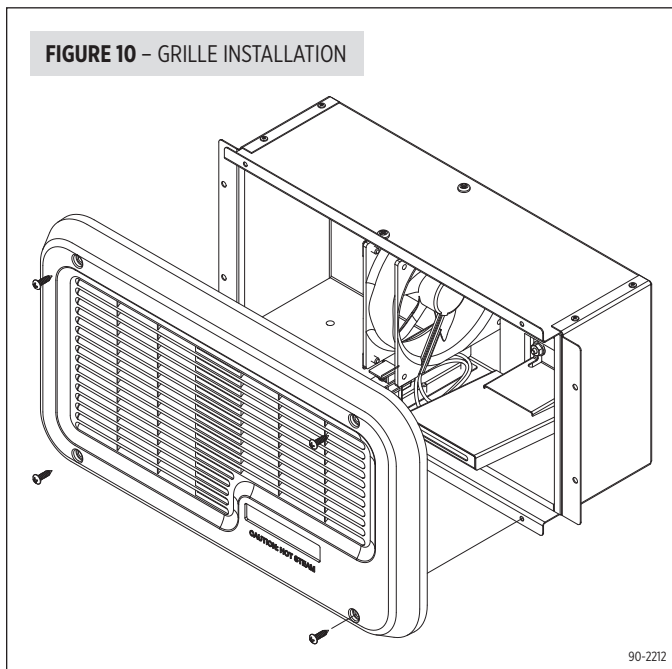
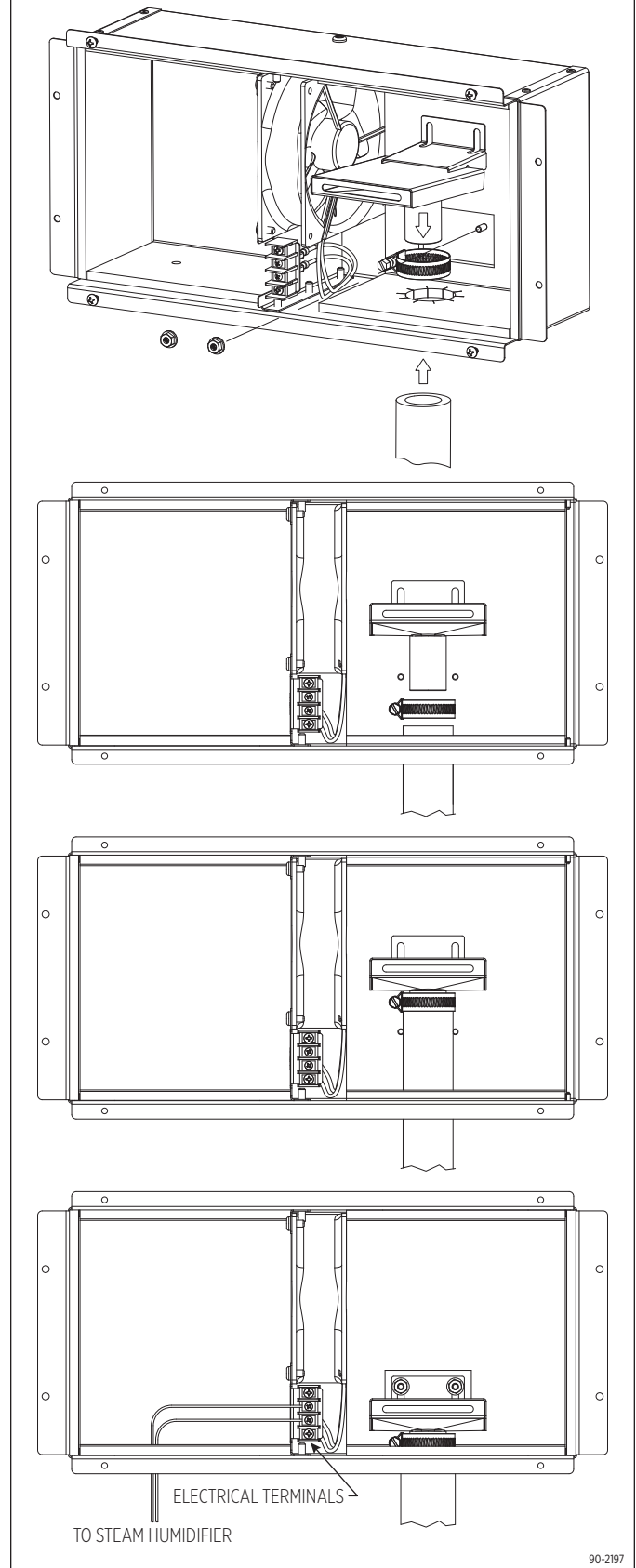

FIGURE 9 – HOSE CONNECTIONS



HUMIDIFIER LOCATION

Do not mount humidifier in a location where operating ambient temperature exceeds 140°F or where freezing temperatures may occur. Extreme temperatures may cause the humidifier to leak which can cause damage.

Mount humidifier in a location that allows access for servicing, and clearance to remove front panel for replacing the canister and side panel for access to the electrical components during installation. See **FIGURE 11** for minimum clearances around humidifier.

The humidifier should be mounted as close to the Fan Pack as possible. Allow a minimum of 2" of steam hose to extend straight out of the humidifier before beginning any bends; this will help ensure a tight connection with the top of the canister.

Mount the humidifier to a structurally stable surface that can bear the full load of the humidifier.

The humidifier must be mounted to a vertical surface and must be mounted level in the upright position.

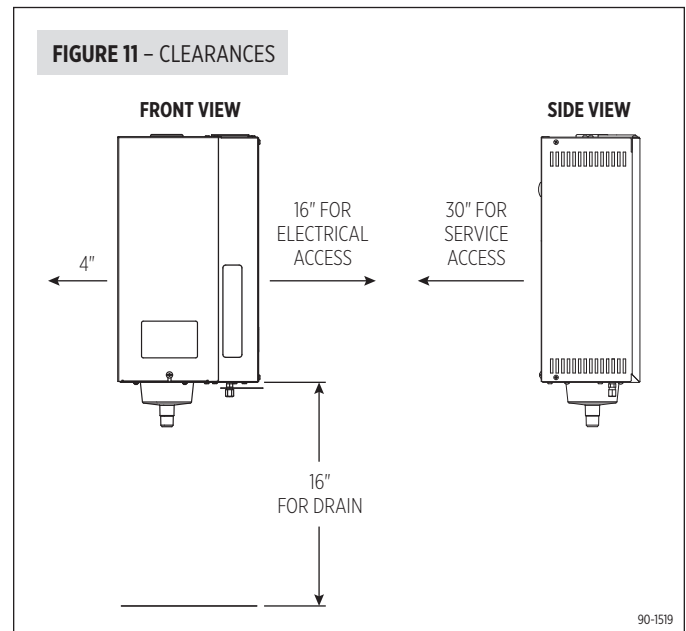

PREPARE HUMIDIFIER FOR MOUNTING

Unpack carton. Open front panel by removing screw and lifting panel up and away from humidifier. Disconnect three wires from top of canister by pulling straight up. The two large wires are the electrode conductors. The smaller wire is connected to the high water level sensor. Remove canister by pulling it up and out of drain assembly. Remove two screws on right side of humidifier and lift side panel off housing to expose electrical compartment.

INSTALL FAN PACK

Make sure the Fan Pack is mounted higher than the humidifier so that condensation that forms in the steam hose runs back into the canister.

MOUNT HUMIDIFIER

Secure humidifier to a sturdy wall using screws provided, or to sheet metal duct. Humidifier initially weighs 23 lbs with a full canister, but will increase in weight over time due to the precipitation of minerals inside the canister. Make sure mounting system will support weight. If mounting to stud frame wall, install two spanner boards to studs and fasten humidifier to spanner boards. Make sure humidifier is mounted plumb.

INSTALL STEAM HOSE

Six feet of steam hose is provided with the humidifier. If the steam hose must be cut, use a hacksaw. If additional length is required, use 1" O.D. metal or copper pipe. **Do not use PVC pipe for steam line.** Insulate pipe with 1" thick insulation rated for 212°F or higher to reduce steam loss.

Use the steam hose provided. Other hoses may have impurities which can cause foaming in the canister. Foaming can cause water level inaccuracies, reduced steam production and water sputtering from the Fan Pack. When using pipe, remove all traces of residual materials used to connect the pipe to prevent foaming.

Verify that the O-ring is in place in the groove in the drain assembly.

Attach steam hose to dispersion tube and then to top of canister using hose clamps provided. Make sure steam hose has a constant slope of at least 2" per foot between the dispersion tube and the humidifier. Support the steam hose in multiple locations over its span to prevent sagging.

Attach and fully seat the electrode conductors (interchangeable) and the high water level sensor wire to the top of the canister.

SUPPLY WATER

Plumb the humidifier to cold, hard or softened water. **Do not use hot water because unheated supply water is used to cool water draining from the humidifier.** Do not use demineralized or reverse osmosis water. For proper operation, supply water pressure must be between 25 psi and 120 psi. Hard or softened water may be used provided it has conductivity between 125 EC and 1250 EC.

Supply water piping must be free of oils, lubricants, solder flux and other contaminants, which can cause foaming.

Follow local plumbing codes. An external backflow preventer may be needed.

Install the saddle valve according to the instructions printed on the bag. Run 1/4" copper tubing from the saddle valve to the humidifier. Connect it to the fill valve. Double wrench to prevent leaking and damage to valve. Addition of a stainless steel braided water line can help reduce valve noise.

NOTE: Adding an inline particulate filter can increase canister life in areas with high levels of suspended solids. DO NOT use filters that release scale inhibitors, filters of this type can significantly decrease canister life.

DRAIN LINE

Attach the 7/8" I.D. drain tubing provided to the drain assembly at the bottom of the humidifier. Secure with the hose clamp provided. Do not over tighten.

Make sure the drain line has a constant downward slope from the humidifier to the drain and is not kinked or blocked.

If floor drain is not available, use condensate pump (Part #4856) to route water to a suitable drain. Provide at least 16 inches for of drain line between the Steam Humidifier and the condensate pump.

NOTE: The humidifier uses cold water to temper drain water to less than 140°F.

ELECTRICAL POWER WIRING & SHUT-OFF SWITCH

CAUTION

Only qualified electrical personnel should perform field wiring procedures. Improper wiring or contact with energized circuits can cause property damage or severe personal injury.

All wiring must be installed in accordance with all governing electrical codes and with the wiring diagram provided inside the front panel.

- Do not loop power wiring.
- Do not use aluminum wire.

A safety grounding system that meets all governing electrical codes is required. The ground connection must be made with solid metal to metal connections. Ground wire must be the same size as the power wiring.

With factory settings, the Steam Humidifier draws 11.5 amps +/- 10%. Use a minimum 20 amp dedicated circuit when installing to operate at 11.5 amps. The Steam Humidifier can be set to draw 16.0 amps +/- 10% by repositioning dip switch #1 on the control circuit board (see **FIGURE 12**). When set to 16 amps, use a minimum 25 amp dedicated circuit. For both applications, size wire according to local codes.

The Steam Humidifier is shipped from the factory wired for 240 VAC operation, but it can operate on 120, 208 or 240 VAC. **If using 120V or 208V, move the black/white jumper wire to the proper tab on the control circuit board.** See **FIGURE 13**.

WIRING INSTRUCTIONS

1. Install disconnect switch (not provided) between line power source and humidifier. Knock-outs for power wiring and low voltage control circuit wiring are provided.
2. Connect power and ground wiring as shown in **FIGURE 13**. Do not run high voltage power lines over internal circuit boards.

FIGURE 12 – CONTROL CIRCUIT BOARD WITH DIP SWITCHES

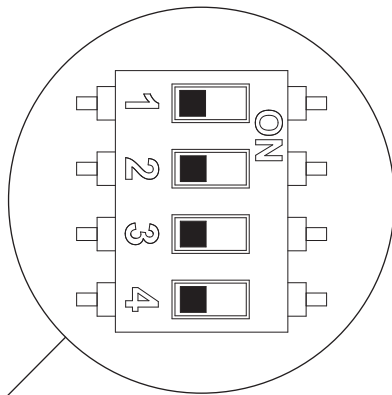
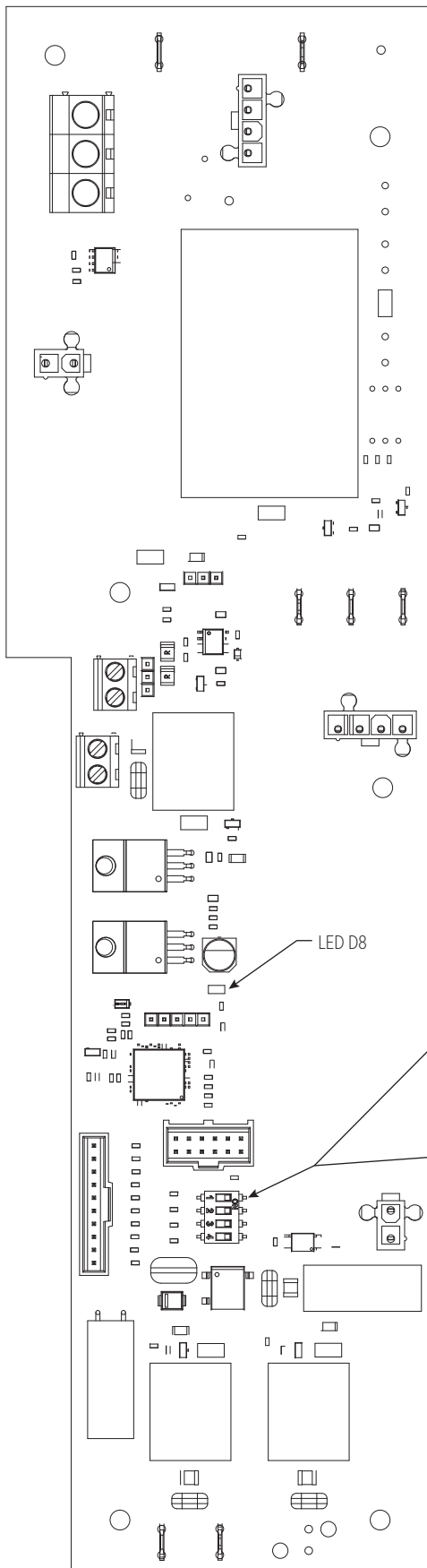

FACTORY SETTING FOR 11.5 AMP NOMINAL OPERATION.

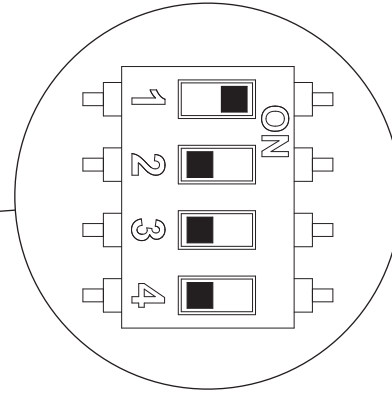

SLIDE DIP SWITCH #1 TO "ON" POSITION FOR 16.0 AMP NOMINAL OPERATION.

FIGURE 13 – 240 VAC WIRING DIAGRAM

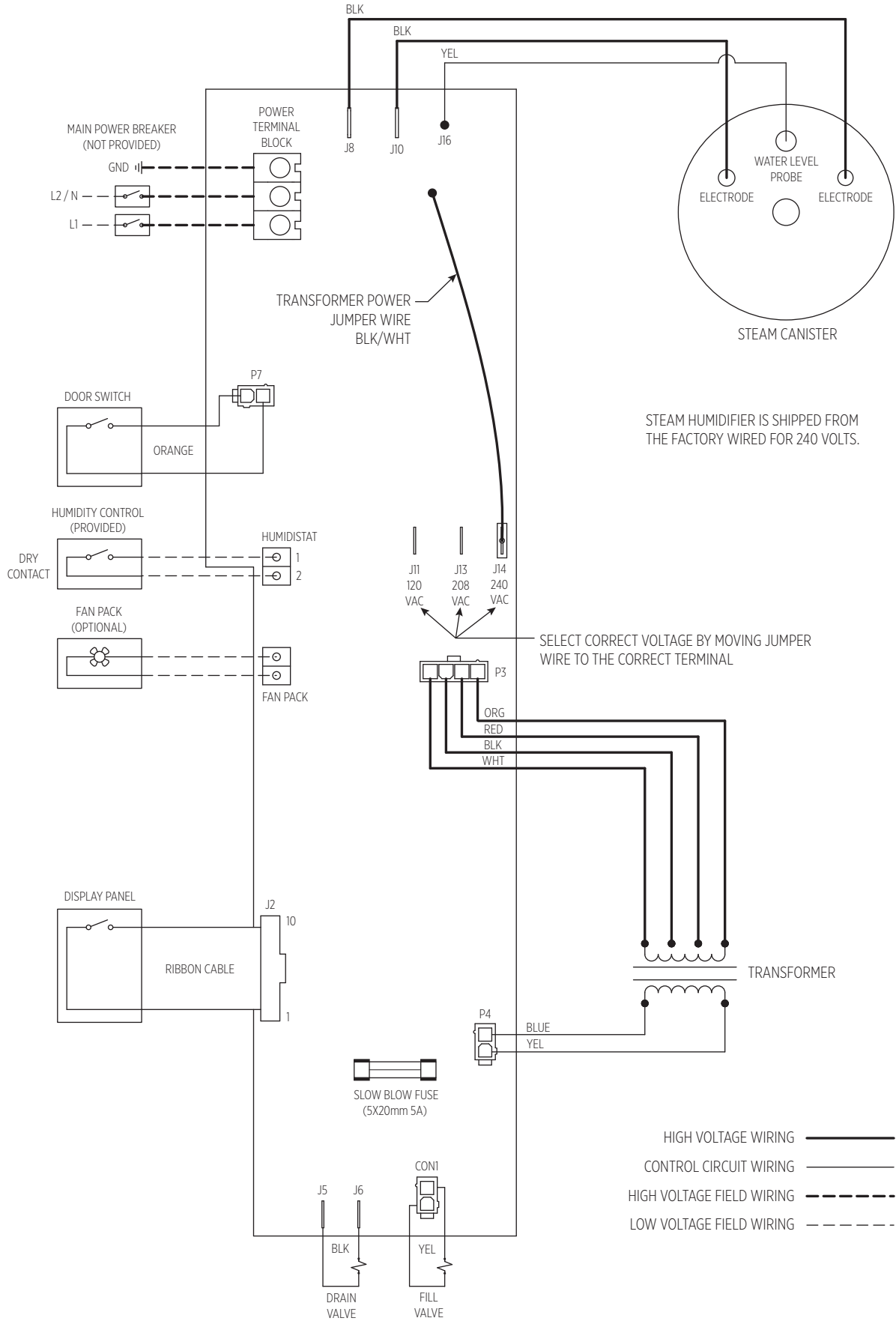

MODEL A65 HUMIDIFIER CONTROL INSTALLATION

DETERMINE LOCATION FOR CONTROL

The Model A65 Humidifier Control should be installed in the space being humidified in order to control moisture levels. See **FIGURE 14**.

Do not mount the control:

- In the flow of a supply register or near the outlet of the Steam Humidifier Fan Pack.
- Behind doors, in corners, or other dead air spaces.
- In direct sunlight, near lighting fixtures, or other appliances that give off heat.
- On an outside or unconditioned area wall.
- In stairwells or near outside doors.
- On a wall with concealed pipes or ductwork.

CAUTION

RISK OF DAMAGE. Disconnect power to humidistat prior to separating humidistat from its base.

1. Pull the front cover from the base.
2. Pull wires through the base hole.
3. Secure the base to the wall using wall anchors and screws (provided).
4. Wire the control. See **MODEL A65 WIRING** on page 14.
5. Install the front cover to the base.

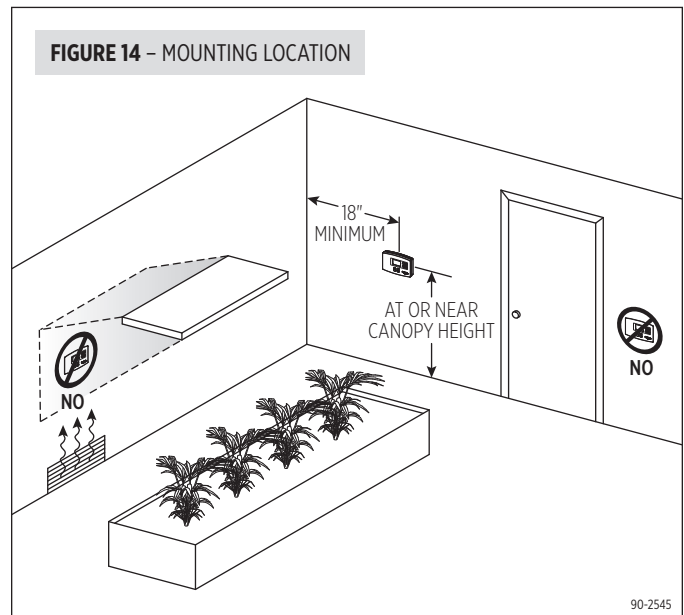

MODEL A65 WIRING

When the Steam Humidifier is installed with the Fan Pack, wire the Model A65 Humidifier Control as shown in **FIGURE 15**.

The Anden Model A65 Humidifier Control is the recommended humidity controller for the Model AS35FP Steam Humidifier.

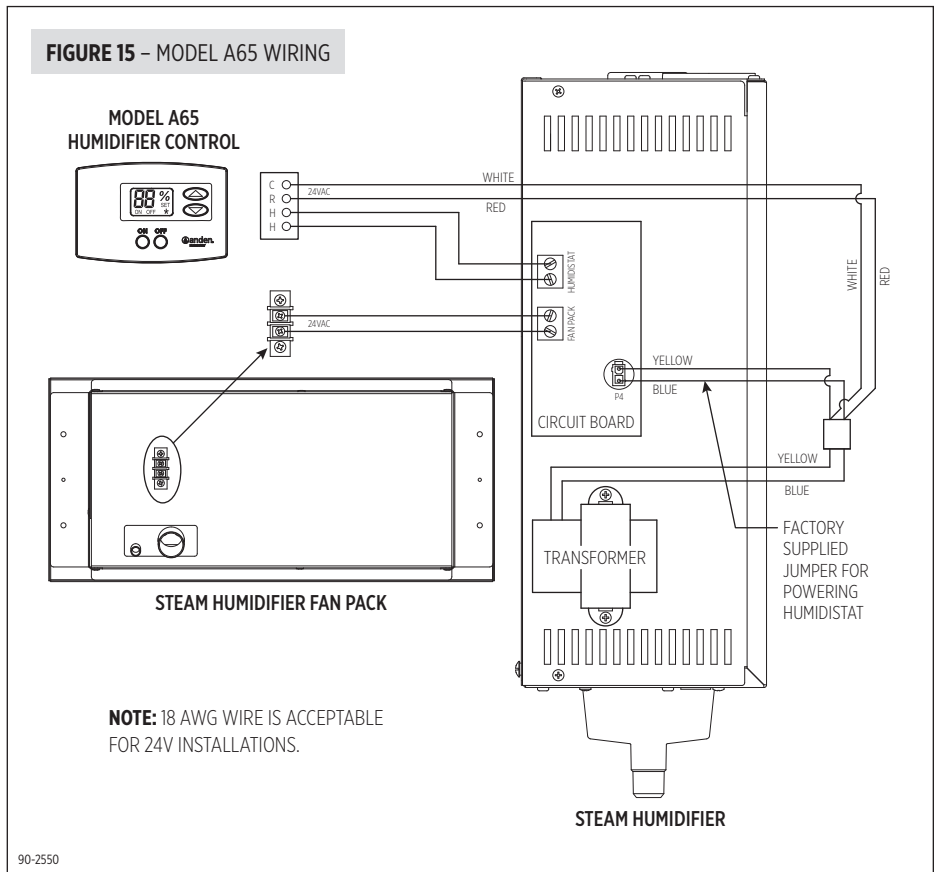

START-UP PROCEDURE

1. Once the supply water, drain, steam hose, electrical power and control wiring connections are complete, make sure canister is fully seated into drain valve and three wire connectors on top of canister are secure. (High water probe wire and two interchangeable electrode wires.)
2. Attach side panel and front door.
3. Open saddle valve allowing water to flow to humidifier. Check for leaks.
4. Close main power switch energizing humidifier.
5. Press **On/Off** button on humidifier. The **On/Off** light will illuminate green.
6. Adjust the humidity set point with the up and down arrows to initiate a call for humidity.

The **Steam** light will illuminate green indicating a call for humidity and the **Fill** light will illuminate green indicating the fill valve is open allowing the canister to fill. You should also hear the water flowing. **If water flows down drain while humidifier is filling, check for kinks or obstructions in the fill hose or fill cup and make sure the O-ring in the drain valve is properly seated in the groove and not damaged or deformed.** Ensure that the Fan Pack fan operates.

7. Once the **Fill** light turns off, to verify that the humidifier will drain properly, press the **On/Off** button to turn humidifier off. You may hear the fill valve open allowing cold water to flow into the canister to cool the water in the canister. The **Drain** light will flash green for 15 seconds then turn green for four minutes while the canister drains. Once the **Drain** light turns off, the drain cycle is complete.

The Fan Pack fan will operate for two minutes after the call for humidity has ended.

8. Set control to proper level.
9. Press **On/Off** button to turn humidifier on.
10. Ensure the steam outlet of the Fan Pack is not blocked.

CAUTION

The front of the Fan Pack will be hot. Steam may not always be visible. Do not touch the front of the Fan Pack or place hand in front of the steam discharge manifold.

OPERATING MODES

When the humidifier is powered and turned on, the **On/Off** light is illuminated green.

During fill cycles, the **Fill** light illuminates green.

When the humidifier is turned on, any time the control sends a call for humidity, the **Steam** light illuminates green.

Any time the drain valve is activated, the **Drain** light illuminates green.

During initial start up with a new canister, the humidifier may run through a series of fill/drain cycles until the conductivity of the water is in a range that allows the humidifier to generate steam at the rated capacity. If the conductivity of the water is low, it may take a week or more for the humidifier to generate steam at the rated capacity. The rated capacity is achieved when the humidifier is detecting a nominal current of either 11.5 or 16.0 amps between the electrodes. If the humidifier has not reached capacity after 168 hours of operation, the **Steam** light will illuminate yellow on a call for humidity. The humidifier will continue to operate with a yellow **Steam** light, and may satisfy the humidity requirements. Once rated capacity is reached, the **Steam** light will illuminate green.

The internal controller adjusts water level in the canister to maintain the nominal current between the electrodes. As minerals build up on the electrodes, their effectiveness decreases, so the controller will increase the water level to submerge more of the electrode surface. When the water has reached the high level probe in the canister and the internal controller no longer detects nominal current, the **Service** light will flash yellow indicating that the canister needs to be replaced.

If the humidifier attempts to fill the canister and cannot, the drain and fill valves will pulse on and off for four seconds to dislodge minerals which may be blocking the drain valve ports. The **Drain** and **Fill** lights will flash on and off when this occurs.

Any time power is disconnected, the internal timer for start-up and drain cycles is reset.

If the humidifier has operated 168 hours without a drain cycle, the drain valve will open and drain the canister. Normal operation will continue.

If the humidifier is operating and a power failure occurs, once power is restored, the **On/Off** light will flash green for one minute, then the humidifier will turn on.

END OF SEASON/PERIOD OF INACTIVITY SHUT-DOWN

If 72 hours elapses without receiving a call for humidity, the canister will automatically drain. The **Drain** light will remain lit for 24 hours. This may also occur during periods of inactivity during the humidification season. The humidifier will resume normal operation when a call for humidity is made.

SHUT DOWN PROCEDURE

To turn humidifier off, push **On/Off** button once. Humidifier will begin its four-minute drain cycle. Fill valve will open to temper drain water. The **Drain** light will flash green for 15 seconds then turn green for four minutes while the canister drains. Once the **Drain** light turns off, the drain cycle is complete and the humidifier is off.

DISPLAY PANEL

Green lights indicate normal operation.





Yellow **Steam** light indicates humidifier is operating at less than rated capacity.

Flashing yellow **Service** light indicates canister is near the end of its life and should be replaced if the humidity in the space cannot be maintained.

Solid yellow lights indicate humidifier has shut down and requires service.

Disconnecting power to humidifier resets internal timers.

TABLE 2 – DISPLAY PANEL

Indicator	Light	Function
 On/Off	Off	Humidifier is turned off or power is disconnected.
	Solid green	Humidifier is turned on.
	Flashing Green	Humidifier is preparing to turn on. Occurs if power to humidifier was turned off when humidifier was on. Humidifier turns on after light flashes for one minute.
 Fill	Off	Fill valve not energized.
	Solid Green	Fill valve is energized, filling or replenishing canister with water. (During drain cycle when fill valve is open allowing cold water into canister to temper drain water, the Fill light does not illuminate.)
	Flashing Green	Fill and drain valves are pulsing to dislodge mineral deposits from drain. Flashes 10 times in 4 seconds. Occurs if high water probe detects water during drain cycle.
 Steam	Off	Humidifier is not producing steam
	Solid Green	Humidifier is turned on and receiving a call for humidity from the control.
	Solid Yellow	Humidifier is producing steam but at less than the rated capacity. Occurs if humidifier has operated for 168 hours and has not reached nominal current. Use replacement canister AS80LC.
 Drain	Off	Drain valve not energized.
	Solid Green	Drain valve is energized, allowing water to drain from canister.
	Flashing Green	Humidifier is preparing to drain. Flashes for 15 seconds indicating fill valve is open allowing cold water into canister.
 Service	Flashing Yellow	Canister has reached end of life. Humidifier continues to operate but at reduced capacity. Occurs after humidifier has operated for 168 hours plus another 24 hours at less than 75% of the maximum operating current level between electrodes.
	Solid Yellow	Humidifier is not operating and requires service.

MAINTENANCE

⚠ WARNING

ELECTRIC SHOCK HAZARD. Disconnect main electrical power to the humidifier at the circuit breaker and drain the water from unit before servicing. Hot surface inside.

NOTICE

- Service should be performed by an HVAC technician.
- Use only genuine replacement parts.

INSPECT HUMIDIFIER WHEN SERVICING

- Replace canister and O-ring annually or when “Service” light turns on
- Clean drain valve and fill valve screen annually
- Replace electrode wires every 3 years or as needed (see step 3 of **CANISTER REPLACEMENT AND DRAIN VALVE SERVICE**)

SERVICE SHUTDOWN PROCEDURE

1. Press **On/Off** button to turn humidifier off (see **FIGURE 16**).
2. Allow humidifier to drain.
3. When the green **Drain** light (see **FIGURE 16**) stops flashing, disconnect main electrical power to humidifier at the circuit breaker.
4. Allow the unit to cool.
5. Shut off water supply to unit.

FIGURE 16 – STEAM HUMIDIFIER

- 1 On/Off button and light
- 2 Drain light
- 3 Front panel
- 4 Side panel
- 5 Service light

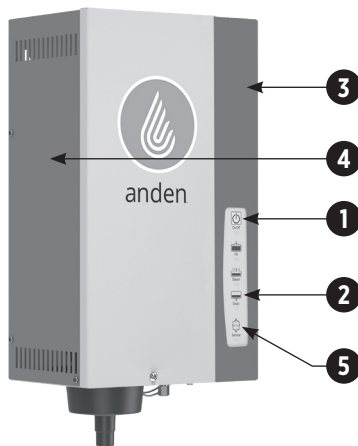

CANISTER REPLACEMENT AND DRAIN VALVE SERVICE

1. Remove front panel (see **FIGURE 16**).
2. Pull three wires off posts on top of canister (two electrode wires and one water level probe wire, shown in **FIGURE 17**).
3. Inspect the two electrode wires (see **ELECTRODE WIRE REPLACEMENT** section for detailed instructions).

Replace them if they are:

- Not tightly fitting
- Damaged
- Over 3 years old or age is unknown
- Have D shaped connectors (see **FIGURE 18A**)

FIGURE 17 – ELECTRODE LOCATION

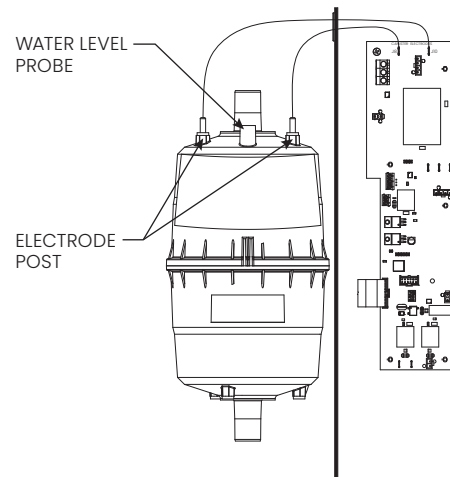

90-2352

FIGURE 18A – “D” SHAPED CONNECTOR

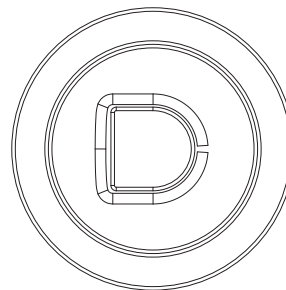
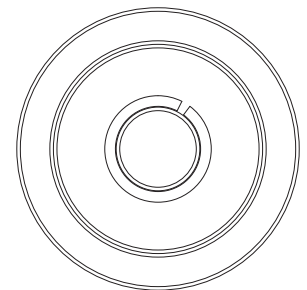

FIGURE 18B – “O” SHAPED CONNECTOR



90-2736

4. Loosen hose clamp at top of canister. Slide steam hose off top of canister (see **FIGURE 19**).
5. Slide canister up and out of drain assembly (see **FIGURE 19**). Discard old canister.
6. Remove O-ring from drain assembly using small screwdriver. Discard old O-ring.
7. With your finger, swirl the fluid/precipitate mixture in the bottom of the drain valve reservoir (see **FIGURE 19**).
8. Using a sponge or paper towels, soak up the water in the reservoir. If necessary, use a wet/dry vacuum to remove residue.
9. Clean the inside of the drain port (where coil projects out) by gently swabbing with a bent cotton swab or other soft implement.
10. Rinse the drain valve reservoir with clean water and vacuum as necessary.
11. Insert new O-ring (Part #5258) into slot in drain assembly. Dampen O-ring with water before inserting canister. Do not use oil, grease, or any lubricant besides water.
12. Make sure strainer is inserted into bottom of new canister.
13. Insert new canister into drain assembly (see **FIGURE 19**).
14. Slip steam hose over top of canister and tighten hose lamp (see **FIGURE 19**).
15. Reconnect the electrode wires and water level probe wire to the posts on top of the canister (see **FIGURE 17**). Electrode wires are interchangeable and can be placed on either of the two electrode posts on top of the canister. **Ensure connectors are fully seated.**

ELECTRODE WIRE REPLACEMENT

1. Remove front panel (see **FIGURE 16**).
2. Remove side panel (see **FIGURE 16**).
3. Remove the electrode wires (see **FIGURE 17**). Use needle nose pliers to pull the spade connectors off spade terminals J8 and J10 on the circuit board.
4. Ensure the two replacement electrode wires (Part #4978) have “O” shape connectors (see **FIGURE 18B**). **Do not use replacement wires with “D” shape connectors** (see **FIGURE 18A**).
5. Attach the new electrode wires (see **FIGURE 17**). Use a pair of needle nose pliers to attach the spade connectors to the spade terminals J8 and J10 on the circuit board. Electrode wires are interchangeable and can be placed on either of the two terminals.

FILL VALVE SERVICE

1. Disconnect water supply line from fill valve inlet (see **FIGURE 19**).
2. Remove in-line strainer from the fill valve inlet port using a #8 or #10 sheet metal or wood screw with a minimum length of 0.5”.
3. Clean or replace in-line strainer (Part #4004).
4. Reconnect water supply line to fill valve inlet (see **FIGURE 19**).

RESTORE UNIT TO SERVICE

1. Replace side panel if removed (see **FIGURE 16**).
2. Replace front panel (see **FIGURE 16**).
3. Inspect drain hose to make sure it is not blocked and has constant downward slope. Clean or replace if necessary.
4. Inspect and clean condensate pump (if used).
5. Inspect steam hose to make sure it has no low spots and has constant upward slope from humidifier to dispersion tube in duct. If dispersion tube is mounted below humidifier, inspect drip tee and drain trap.
6. Restore main electrical power to humidifier at circuit breaker.
7. Turn humidifier on and verify green **On/Off** light is illuminated (see **FIGURE 16**).
8. Check system operation and inspect all plumbing connections and piping for signs of cracks or leaks.

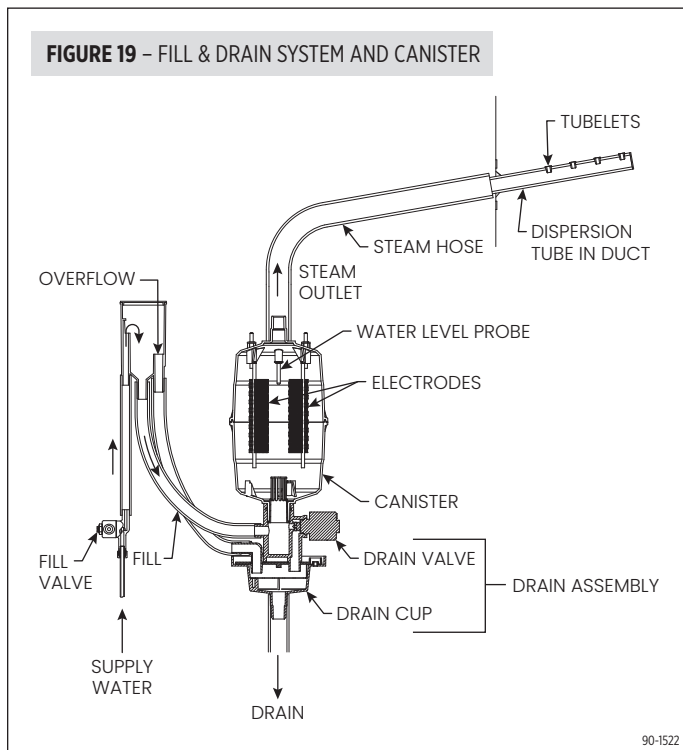

TROUBLESHOOTING

⚠ CAUTION

Contact with electrical circuits can cause property damage, personal injury or death. Service and Troubleshooting must be performed by qualified electrician.

The following troubleshooting guide is intended to help diagnose and resolve general operational problems with the Steam Humidifier and optional Fan Pack. If a problem persists, call Anden Tech Support toll-free at 1-800-972-3710. Please be prepared to describe the exact nature of the problem. For general operational problems, check to make sure humidifier is installed correctly.

TABLE 3 – HUMIDIFIER TROUBLESHOOTING GUIDE

Problem	Possible Cause	Action
General operating problems. Humidifier will not turn on or turn off.	Field-wired terminal connections.	Verify L1, N/L2 and ground connections are properly wired and appropriate voltage is present.
		Check HUMIDISTAT and (if used) FAN PACK terminal connections are tight and properly wired.
		HUMIDISTAT terminals must be connected to an on/off device.
		Check wiring connections and settings on Accessory items such as high limit switch and airflow proving switch.
	Internal connections.	Check electrode and high water probe connections on the top of the canister.
		Make sure ribbon cable from membrane switch is securely plugged into control circuit board.
		Make sure black/white wire is attached to terminal that matches input voltage.
	No power to humidifier.	Check main power supply and switch.
		Ensure breaker is sized appropriately for the amperage draw.
		Check for proper voltage across L1 and N/L2 terminals.
	Humidifier not turned on.	Make sure front cover is attached to engage safety interlock switch. Press On/Off button.
		Make sure ribbon cable from membrane switch is not damaged and is securely plugged into the control circuit board.
No power to 24 volt control circuit.	Check fuse on PCB (replace with 5 amp slow burn fuse if necessary).	
	With humidifier energized, check that LED light D8 is energized on the circuit board. If the LED is lit, replace the membrane switch, if not, replace the circuit board.	
Steam light does not turn on.	Call for humidity not being received.	Check humidistat wiring and setting.
		Check wiring and settings of high RH limit switch and airflow proving switch.
Water is leaking from humidifier.	Loose plumbing connections.	Check water supply connection at fill valve inlet. Tighten as needed.
		Check internal hose clamp connections. Reposition clamps and tighten as needed.
		Check steam hose connection on top of canister. Tighten clamp as needed.
	Hoses are blocked.	Check internal hoses and eliminate kinks or blockage.
	Drain hose is blocked.	Make sure drain hose has constant downward slope and is not blocked.

TABLE 3 – HUMIDIFIER TROUBLESHOOTING GUIDE

Problem	Possible Cause	Action
Water constantly runs down drain.	Debris in drain valve preventing it from closing.	Remove canister and clean debris from drain valve.
	O-ring in drain valve is not properly seated in groove.	Remove canister and check O-ring for damage. Replace O-ring as necessary. Ensure O-ring is properly seated in its groove.
	Water is flowing from fill cup overflow port.	Check internal hoses and eliminate kinks or blockage.
	High static pressure in duct is causing back pressure in canister.	Make sure dispersion tube is not discharging into duct with greater than 2.0 in.wg static pressure. Make sure dispersion tube tubelets are pointed up.
Humidifier is filling and water is flowing down drain but Drain light is not on.	High static pressure in steam line is causing back pressure in canister.	Install a tee and drain trap in any low points in the steam line. See FIGURE 6 .
Humidifier makes gurgling sound.	Excess condensation in steam hose.	Install Tee and Trap Model 4028 as shown in FIGURE 6 .
		Make sure steam hose has constant downward slope to humidifier or to tees and traps in low spots of hose.
		If hard pipe is used for dispersion system, make sure it is insulated.
Fill valve makes banging sound.	Water hammer from line pressure.	Make sure water supply line does not contact ductwork.
		Install shock arrestor.
		Install section of 1/4" braided fill line. Conform to local codes.
		If water supply pressure is greater than 120 psi, install pressure reducer.
Humidifier will not fill.	Saddle valve not open or pipe not pierced.	Make sure saddle valve is properly installed and the valve is open.
	Hoses are blocked.	Check internal hoses and eliminate kinks or blockage.
Humidifier will not drain.	Debris in drain valve blocking outlet port.	Remove canister and clean debris from drain valve.
Service light flashing yellow before end of humidification season.	Canister full of mineral deposits.	Remove canister and rinse with clean water.
		Plumb humidifier to filtered water.
		Plumb humidifier to softened water.
Yellow Steam light.	Humidifier operating below rated capacity. (Normal operation for systems plumbed to low conductivity water and systems that operate for short cycles.)	Plumb humidifier to softened water.
		Use AS80LC canister.
		Operate humidifier on 208/240 volts.
		To determine operating current, attach clamp-on ammeter to one of the electrode wires on top of canister.
		Dissolve one teaspoon of salt into one cup of hot water. Add to the fill cup in 1/4 cup increments until unit operates properly. Yellow Steam light will clear after first fill valve cycle at nominal amperage operation. Do not over salt. System will drain and refill with clean water due to over current fault.
Humidifier is not satisfying demand.	Control setting is too low.	Adjust control to higher setting.
	Control mounted in wrong location.	See Installation Instructions with control for correct mounting location.
	Humidifier capacity limited by input power (120V).	Operate humidifier on 208/240 volts. Increase capacity to 16.0 amps. Make sure breaker is appropriately sized.

TABLE 3 – HUMIDIFIER TROUBLESHOOTING GUIDE

Problem	Possible Cause	Action
Excess humidity.	Control setting is too high.	Adjust control to lower setting.
	Control mounted in wrong location.	See Installation Instructions with control for correct mounting location.
Solid yellow Fill light.	Fill valve has been filling for 40 minutes.	Make sure high water pin wire is securely installed.
	Low spot in steam hose collecting water.	Support steam hose along its length ensuring 2" per foot slope from the dispersion tube to the humidifier.
	High static pressure in the duct is causing back pressure in the duct.	Make sure dispersion tube is not discharging into a duct with greater than 2.0 in.wg. static pressure. Make sure dispersion tube tubelets are pointed up.
Solid yellow Service light.	Unit senses current 120% above nominal and cannot lower amperage after three drain cycles.	Rinse canister to remove mineral deposits or install a new canister.

TABLE 4 – FAN PACK TROUBLESHOOTING GUIDE

Problem	Possible cause	Action
Water dripping from Fan Pack	Tubing connection	Check all connections.
	Fan not operating	See "Fan does not operate".
	Steam outlets blocked	Clean steam dispersion manifold outlet.
	Foaming in canister or steam hose	Rinse components with clean water.
	Air drafts in the space	Do not install near supply ducts or ceiling fans.
Fan does not operate	Wiring	Check wiring.
	Steam Humidifier power	Check that the Steam Humidifier is powered and on.
	No humidity call	Adjust humidistat setting. Check location of humidistat.
	Circuit board output	Confirm 24 VAC output from the Steam Humidifier FAN PACK terminals during a call for humidity. Confirm that the Steam Humidifier contains a 75 VA transformer.
	Motor failure	Replace fan motor.
Noise	Fan noise	Check for obstructions or damage to fan.
	Gurgling	Add a drip tee and trap (PN 4028) to the steam line as close to the Steam Humidifier as possible to divert condensation to drain. See FIGURE 6 .

REPLACEMENT PARTS

Refer to the following page for part descriptions.

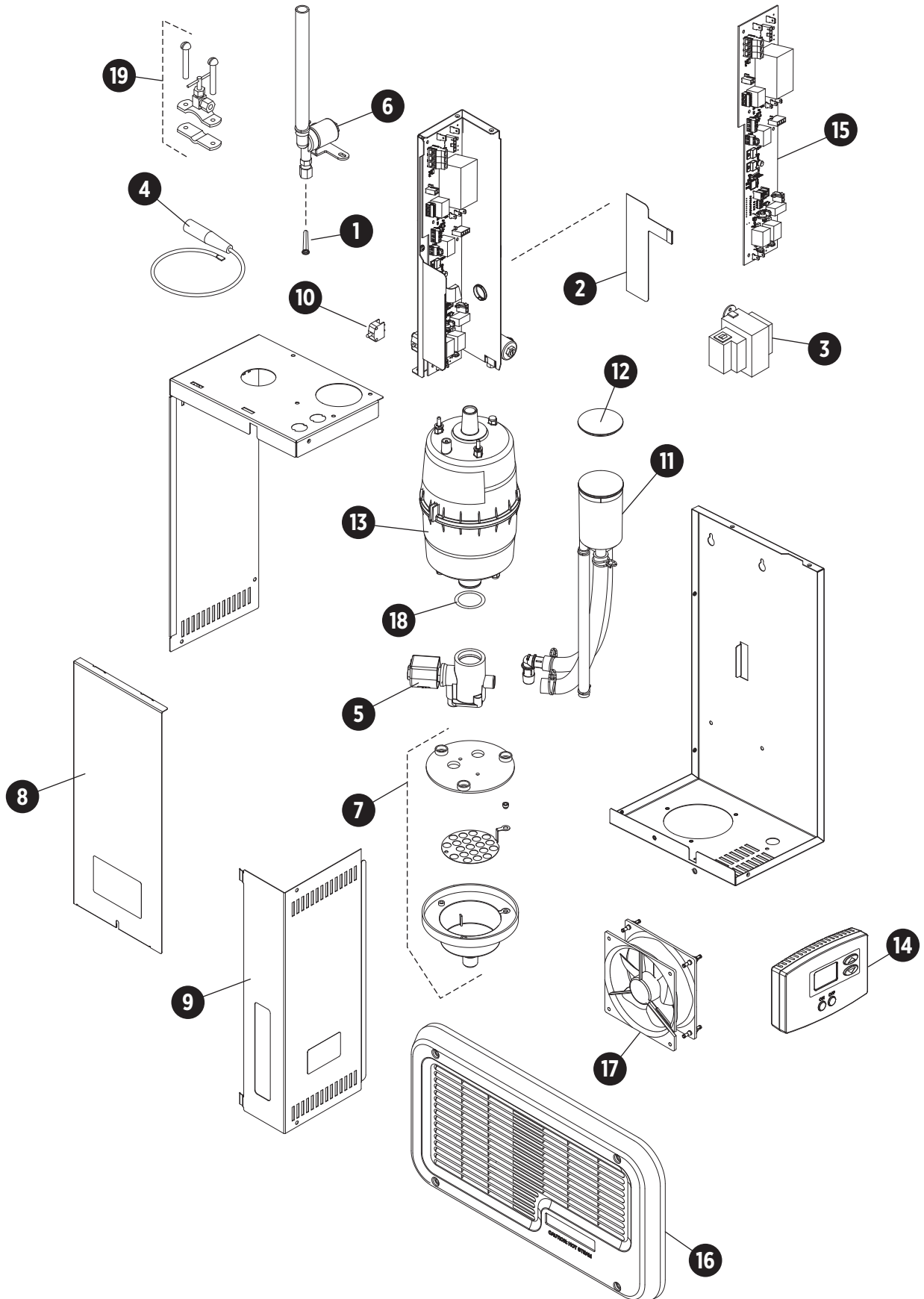

Item No.	Part No.	Description
1	71000001	Fill Valve In-line Strainer
2	71000002	Membrane Switch
3	71000003	Universal Transformer (75 VA)
4	71000004	Electrode Wires (2)
5	71000005	Drain Valve
6	71000006	Fill Valve
7	71000007	Drain Cup Assembly
8	71000008	Front Panel & Screw
9	71000009	Electrical Access Panel & Screws
10	71000010	Safety Interlock Switch
11	71000011	Fill Cup & Hoses
12	71000012	Fill Cup Cap

Item No.	Part No.	Description
13	AS80	Steam Canister and O-Ring
14	A65	Humidifier Control
15	71000014	Control Board
16	71000015	Fan Pack Grille
17	71000016	Fan Pack Fan
18	71000017	O-ring
19	71000018	Saddle Valve
	71000019	Drain Trap & Tee
	71000020	Condensate Pump (Rated for 160°F)
	71000021	Steam Hose (6 ft.) & Clamps
	71000022	Drain Hose (10 ft.) & Clamps
	71000047	Parts Bag, AS35FP, Anden, RSH

MODEL A65 HUMIDIFIER CONTROL SPECIFICATIONS

CONTROL

Humidity Setting Range	10% – 90% RH
Accuracy	+/-5% RH
Differential	3%
Low Temp	40°F
High Temp	99°F

ELECTRICAL

Input Voltage and Current	Voltage: 24V AC +/-20% Current: 25mA (nominal), 50mA (max.) at 24V AC
Output	Dry Contact, Normally Open – H Terminals

LIMITED WARRANTY

Your Research Products Corporation Anden® Steam Humidifier is expressly warranted for five (5) years from date of installation to be free from defects in materials or workmanship.

Research Products Corporation's exclusive obligation under this warranty shall be to supply, without charge, a replacement for any component which is found to be defective within such five (5) year period and which is returned not later than thirty (30) days after said five (5) year period by you to either your original supplier or to Research Products Corporation, Madison, Wisconsin 53701, together with the model number and installation date of the steam humidifier.

THIS WARRANTY SHALL NOT OBLIGATE RESEARCH PRODUCTS CORPORATION FOR ANY LABOR COSTS AND SHALL NOT APPLY TO DEFECTS IN WORKMANSHIP OR MATERIALS FURNISHED BY YOUR INSTALLER AS CONTRASTED TO DEFECTS IN THE STEAM HUMIDIFIER ITSELF.

IMPLIED WARRANTIES OF MERCHANTABILITY OR FITNESS FOR A PARTICULAR PURPOSE SHALL BE LIMITED IN DURATION TO THE AFORESAID FIVE YEAR PERIOD. RESEARCH PRODUCTS CORPORATION'S LIABILITY FOR INCIDENTAL OR CONSEQUENTIAL DAMAGES, OTHER THAN DAMAGES FOR PERSONAL INJURIES, RESULTING FROM ANY BREACH OF THE AFORESAID IMPLIED WARRANTIES OR THE ABOVE LIMITED WARRANTY IS EXPRESSLY EXCLUDED. THIS LIMITED WARRANTY IS VOID IF DEFECT(S) RESULT FROM FAILURE TO HAVE THIS UNIT INSTALLED BY A QUALIFIED HEATING AND AIR CONDITIONING CONTRACTOR. IF THE LIMITED WARRANTY IS VOID DUE TO FAILURE TO USE A QUALIFIED CONTRACTOR, ALL DISCLAIMERS OF IMPLIED WARRANTIES SHALL BE EFFECTIVE UPON INSTALLATION.

Some states do not allow limitations on how long an implied warranty lasts or the exclusion or limitation of incidental or consequential damages so the above exclusion or limitations may not apply to you.

This warranty gives you specific legal rights and you may also have other rights which vary from state to state.

WARRANTY REGISTRATION

Visit us online at anden.com to register your Anden product. If you do not have online access, please mail a postcard with your name, address, phone number, email address, product purchased, model number, date of purchase, and dealer name and address to: Research Products Corporation, P.O. Box 1467, Madison, WI 53701.

Your warranty registration information will not be sold or shared outside of this company.

anden.com

P.O. Box 1467

Madison, WI 53701-1467

800.972.3710 F: 608.257.4357

Printed in USA

©2021 Anden – A Quality brand from Research Products Corporation

10016611 B2210099A 10.22

