



VAPOR LOGIC® Version 6 Humidifier Control System

Installation and Operation Manual



READ AND SAVE THESE INSTRUCTIONS

Table of contents

Anden Technical Support
800-972-3710









WARNINGS AND CAUTIONS	iv
OVERVIEW	1
Vapor-logic capabilities	1
Vapor-logic board	3
Keypad/display	5
Web interface	6
Pre-installation Checklist	7
INSTALLATION	7
Installation process	9
Step 1 – Field wiring:	10
Control input	10
Control input signals	12
Vapor-logic keypad/display	14
Limit controls	14
Field wiring	19
Sensor placement	20
Step 2 – Setup	21
Using the keypad/display	21
Setup screen	22
Using the Web interface	22
Step 3 – Startup	28
Using menus and screens	29

Table of contents

OPERATION	29
Home screen (keypad/display)	30
Changing mode and set point.	30
Tank activities defined	30
Status screen.	31
Diagnostics screen.	34
Alarms screen.	39
PID tuning.	42
Improves humidifier response time	42
The proportional term.	42
The integral term	43
The derivative term	44
PID band	44
PID setup tips	45
Electrode steam humidifiers.	46
Freeze protection.	47
Fan-based dispersion operation.	47
Sensor offsets	47
Automatic drain sequence, tap/softened water	48
Draining when using softened water	49
End-of-season drain	49
Service interval	49
Setting date and time.	50
Battery backup, nonvolatile memory	50
Security/password.	50
Downloading historical data	51
Backing up and restoring data	51
Firmware updates	52
Downloading firmware updates.	52
Installing firmware updates.	55
Test outputs and test run.	56
Modbus and BACnet interoperability.	57
Connections	57
Installing LonTalk as a retrofit	57
Troubleshooting guide	67

Warnings and cautions

 WARNING	CAUTION
<p>Indicates a hazardous situation that could result in death or serious injury if instructions are not followed.</p>	<p>Indicates a hazardous situation that could result in damage to or destruction of property if instructions are not followed.</p>

 WARNING	
	<p>Read all warnings and instructions</p> <p>This page provides important safety instructions; it is intended to supplement — not replace — the humidifier's Installation, Operation, and Maintenance Manual (IOM). Read the IOM that was provided with the humidifier before performing service or maintenance procedures on any part of the system. Failure to follow all warnings and instructions could produce the hazardous situations described here and in the IOM, resulting in property damage, personal injury, or death.</p> <p>If the IOM is missing, go to www.anden.com to download a replacement.</p>
 	<p>Hot surfaces and hot water</p> <p>Steam humidification systems have extremely hot surfaces, and water in tanks, electrode cylinders, steam pipes, and dispersion assemblies can be as hot as 212 °F (100 °C). To avoid severe burns, allow the entire humidification system to cool.</p> <p>Follow the cool-down procedure in the humidifier's IOM before performing service or maintenance procedures on any part of the system.</p>
   	<p>Shut down the energy source</p> <p>Before performing service or maintenance procedures on any part of the humidification system, verify that all energy sources are off. Energy sources can be electricity, gas, steam, or hot liquid. Failure to shut down the energy source could result in carbon monoxide poisoning, fire, explosion, electrical shock, and other hazardous conditions. These hazardous conditions could cause property damage, personal injury, or death.</p> <p>Contact with energized circuits can cause property damage, severe personal injury or death as a result of electrical shock or fire. Do not remove the shroud/cover, electrical panel cover/door, access panels, or heater terminal cover until electrical power is disconnected.</p> <p>Follow the shutdown procedure in the humidifier's IOM before performing service or maintenance procedures on any part of the system.</p>

CAUTION	
<p>Hot discharge water</p> <p>Discharge water can be as hot as 212 °F (100 °C) and can damage the drain plumbing.</p> <p>Humidifiers equipped with a water tempering device need fresh make-up water in order to function properly. Make sure the water supply to the water tempering device remains open during draining.</p> <p>Excessive supply water pressure</p> <p>Supply water pressure greater than 80 psi (550 kPa) can cause the humidifier to overflow.</p>	

Vapor-logic capabilities

ACCURATE, RESPONSIVE CONTROL

The Vapor-logic controller provides accurate, responsive RH control. PID control tunes the system for maximum performance.

Modbus®, **BACnet®**, or **LonTalk®** allow interoperability with multiple building automation systems. Modbus is standard, and BACnet or LonTalk are available options.

Web interface, provides the capability to set up, view, and adjust humidifier functions via Ethernet, either directly or remotely through a network.

Contactor wear leveling (Vaporstream®) distributes cycles among multiple contactors for equal wear and longer contactor life.

Cycle counter (electric humidifiers) triggers a message when it's time to replace contactors.

USB port allows easy firmware updates, and data backup and restore capability.

Real-time clock allows time-stamped alarm and message tracking, and accurate drain and flush scheduling.

Programmable outputs allow remote signaling and device activation.

Multiple-humidifier control allows staged control of up to 16 humidifiers with one controller.

Note: Anden humidifiers do not operate in multi-tank mode; however, up to four Anden AS150 humidifiers can be staged to operate in sequence.

Controller data, such as RH, air temperature, water use, energy use, alarms, and messages, can be downloaded to a PC for viewing and analysis. RH, alarms, and messages can also be viewed on the keypad/display and Web interface.



More capabilities on the next page >

Vapor-logic capabilities

Enhanced diagnostics include:

- **Test outputs** function using keypad/display or Web interface to verify component operation
- **Test humidifier** function using simulated demand to validate performance



Insert a USB flash drive into the Vapor-logic board's USB port to perform software updates, download data logs, and back up and restore data.

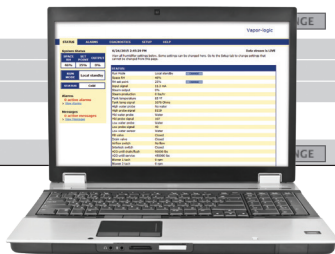
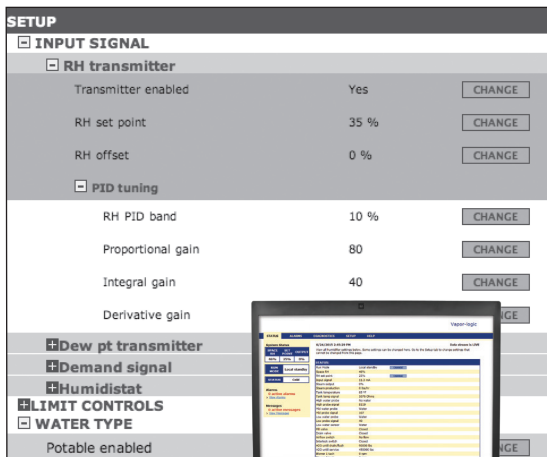

Use the Vapor-logic keypad/display or the standard Web interface, shown here, to control your humidification system. Connect a computer directly to the Vapor-logic board, or through a network, to use the Web interface.

OPERATING CONDITIONS

The Vapor-logic main board and keypad/display must be operated and stored within the limits listed below. Exceeding these limits can result in poor display performance and/or damage to the unit.

Main board

- Operating temperature: 32 °F to 158 °F (0 °C to 70 °C)
- Storage temperature: -40 °F to 185 °F (-40 °C to 85 °C)
- Operating humidity range: <95% noncondensing

Keypad/display

- Operating temperature: 32 °F to 158 °F (0 °C to 70 °C)
- Storage temperature: -22 °F to 176 °F (-30 °C to 80 °C)
- Operating humidity range: <95% noncondensing

Vapor-logic board: Components

FIGURE 3-1: VAPOR-LOGIC CONTROL BOARD

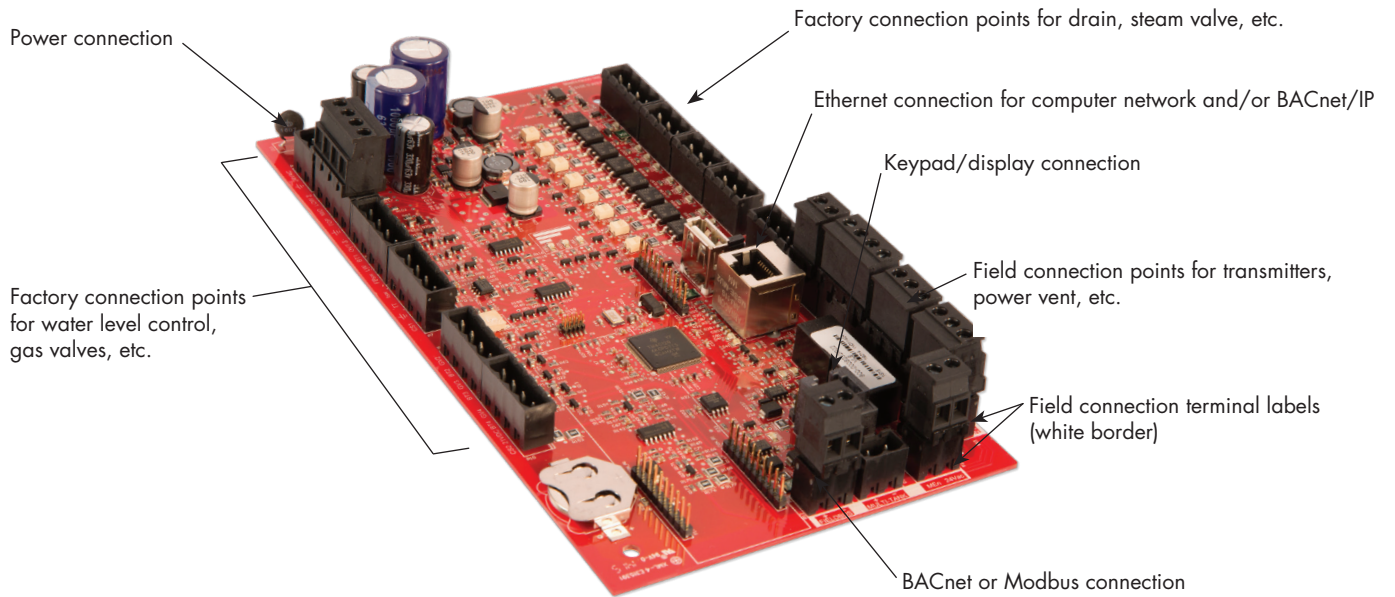

The photo above shows key components of the Vapor-logic control board. See the illustration on the next page for more detail.

Vapor-logic board: Connections

FIGURE 4-1: VAPOR-LOGIC CONTROL BOARD CONNECTIONS

P1:
24vac = Power to board
⊥ = Ground for power return

P2:
Low = Low water probe
Mid = Mid water probe
Top = Top water probe
⊥ = Ground for water probe

P4:
IsW = Interlock switch (24vac input)
TT = Tank temp sensor (RTD input)
⊥ = Ground for tank temp sensor
CS1 = Analog input AS150 current sense (4-20 mA)/HPS inlet pressure/ Flue temp sensor

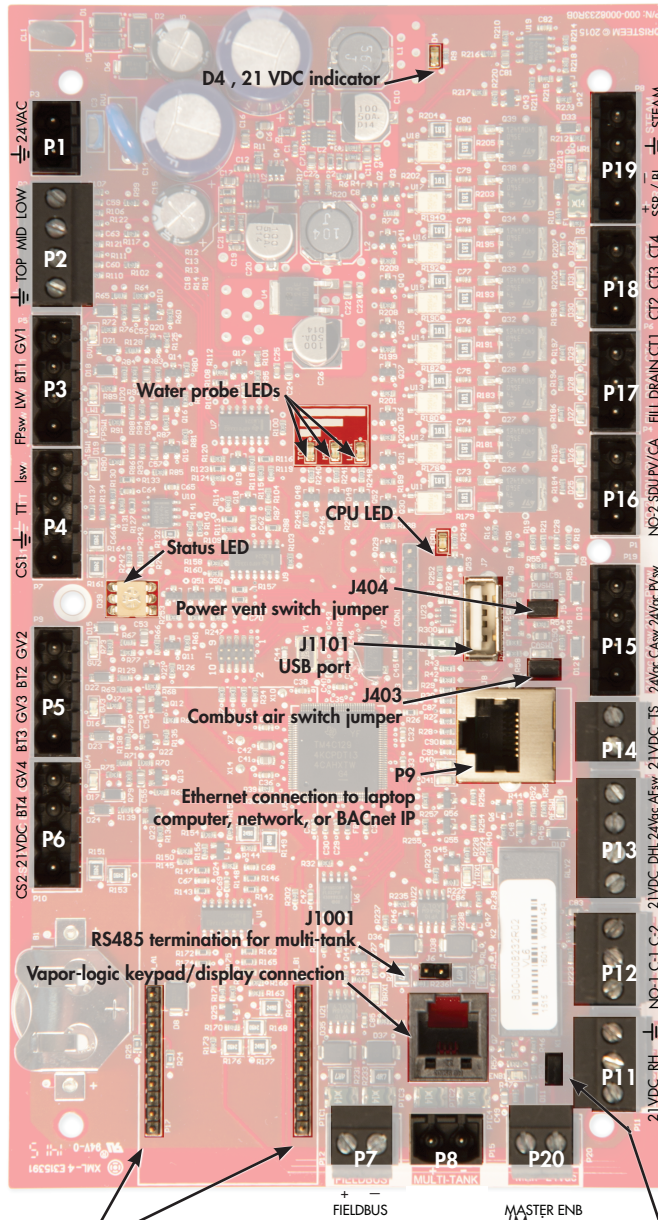

Connection pins for optional LonTalk module

FIELDBUS = Modbus or BACnet MS/TP (RS485)

J402 Main enable jumper

P19:
Steam = Steam or hot water valve/AS150 staging/HPS VFD
⊥ = Ground for blower or steam valve
SSR/BL = SSR (electric systems)/or blower (gas systems)

P18: (all are 24VAC outputs)
CT4 = Contactor 4 (electric systems)/or Ignition module 4 (gas systems)/AS150 dual contactor 2/Z3 drain
CT3 = Contactor 3/Ignition module 3/AS150 dual drain 2/HPS pump 2/Z3 supply
CT2 = Contactor 2/Ignition module 2/AS150 dual fill 2/HPS pump 1/Z2 drain

P17: (all are 24VAC outputs)
CT1 = Contactor 1/Ignition module 1/HPS single zone/Z2 supply
Drain = Drain valve/HPS depressurization/Z1 drain
Fill = Fill valve/HPS flush valve/Z1 supply

P16: (all are 24VAC outputs)
PV/CA = Power vent/combustion air control signal/Thermal trip power/HPS RO enable
SDU = Space Distribution Unit/Area type/ HPS VFD enable

NO-2 = Normally open #2.
* See Caution below.

P15:
PVsw = Power vent switch (24vac input)/STS XV float/STS external demand
24vac = Power to power-vent switch
CAsw = Combust. air sw. (24vac input)
24vac = Power to combustion air switch

P14:
TS = Aux. temp. sensor or temp. comp. sensor (4-20 mA input)/AS150 current sense input dual cylinder/HPS RO pressure
24vdc = Power to aux. temp. sensor or temp. comp. sensor

P13:
AFsw = Airflow proving switch (24vac input)
24vac = Power to airflow proving switch
DHL = Duct high limit switch/transm. (4-20 mA input)
21vdc = Power to duct high limit switch or transmitter

P12:
Programmable relay #1
* See Caution below.
C-2 = Common #2
C-1 = Common #1
NO-1 = Normally open #1

P11:
⊥ = Ground for demand signal by others
RH = Space RH input (RH transmitter, dew point transmitter, humidistat, or demand signal by others (4-20 mA or 0-16vdc typical))
21vdc = Power to space RH sensor

Notes:

- Programmable relay functions are defined using the keypad/display or Web interface during the Setup process.
- For most applications, field connections are made at terminals on the board that are surrounded with a white border (P7, P8, P11-P16, P20).
- This control board is used for several types of humidifier systems (for example, gas humidifiers as well as electric humidifiers). Your application will not have connections at all terminals.

CAUTION

Programmable relay maximum electrical ratings

Programmable relays are rated for 125 VAC, 3 Amp or 30 VDC, 3 Amp maximum. Exceeding these maximum ratings can cause the relay components on the Vapor-logic board to fail.

Keypad/display

FIGURE 5-1: USING THE VAPOR-LOGIC KEYPAD/DISPLAY

Typical Home screen

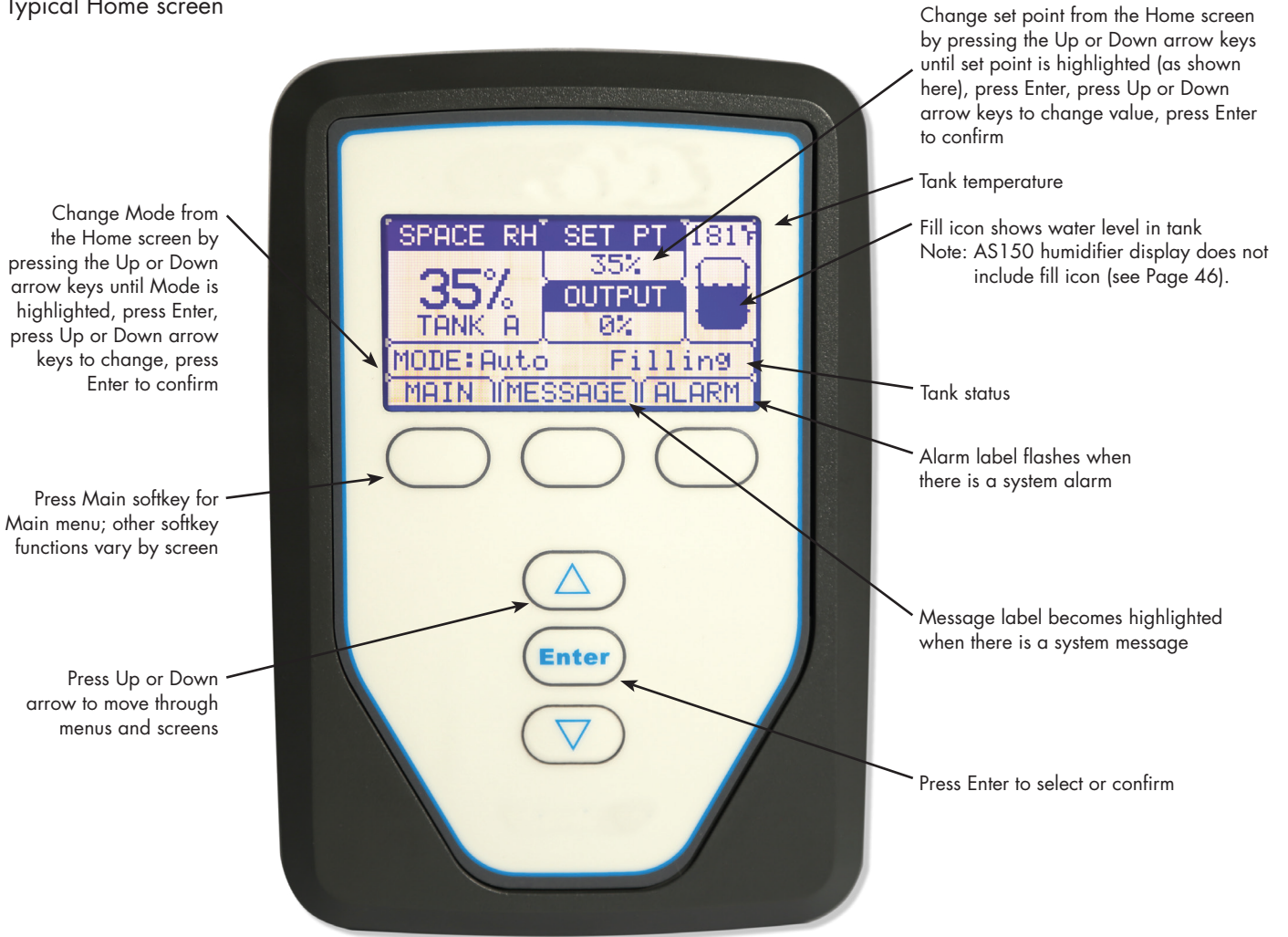

Web interface

FIGURE 6-1: USING THE VAPOR-LOGIC WEB INTERFACE (SETUP SCREEN SHOWN)

The screenshot displays the Vapor-Logic web interface. At the top, a navigation bar contains tabs for STATUS, ALARMS, DIAGNOSTICS, SETUP (highlighted), and HELP. A callout box points to the tabs with the text: "Click on a tab label to move to another screen".

On the left side, there is a sidebar with the following sections:

- System Status**: A table with columns DEMAND and OUTPUT. DEMAND is 73.3% and OUTPUT is 0%.
- RUN MODE**: A dropdown menu currently set to Auto.
- TANK STATUS**: A dropdown menu currently set to Idle.
- Alarms**: Shows "0 active alarms" with a link to "View Alarms".
- Messages**: Shows "1 active message" with a link to "View Messages".

Callouts for the sidebar:

- "Click here to view alarms" points to the "View Alarms" link.
- "Click here to view messages" points to the "View Messages" link.
- "Click on label to contract (-) or expand (+) menu item" points to the plus sign next to "Messages".

The main content area shows the date and time: "Tuesday, May 22, 2012 4:30:14 PM" and a status "Data stream is LIVE". Below this is a descriptive paragraph: "Set or change all humidifier settings below. Humidifiers are sent from the factory configured as ordered. However, some settings are unknown at the factory and need to be defined on this page."

The main content area is titled "SETUP" and contains several expandable sections:

- + INPUT SIGNAL
- + LIMIT CONTROLS
- WATER MANAGEMENT
 - End of season drain
 - EOS enabled: Yes (CHANGE button)
 - Idle time for EOS: 72 hours (CHANGE button)
 - Service interval
 - Service interval: 30000 lbs (CHANGE button)
- + FAN-BASED DISPERSION
- + COMMUNICATIONS
- + PROGRAMMABLE OUTPUTS
- + SET DATE AND TIME
- + LANGUAGE
- + UNITS
- + SECURITY
- + CAPACITY ADJUST
- + RESET TO DEFAULTS

Callouts for the main content area:

- "Click on CHANGE to change value" points to the CHANGE button for "EOS enabled".
- "To change value: Highlight value; type in new value; click on APPLY" points to the "30000 lbs" value in the "Service interval" row.

Pre-installation Checklist

- ❑ See Figure 7-1 for field terminal block locations. Note that field wiring connection locations on the Vapor-logic board are surrounded with a white border.
- ❑ See the figure on the next page for instructions on how to make wiring connections.
- ❑ See the wiring drawings and manuals that shipped with your humidifier.
- ❑ When making field connections, do not route low voltage wires near line voltage wires. Do not route low voltage wires in the same conduit as line voltage wires.
- ❑ Humidistat, room/duct transmitter, temperature sensor, and airflow proving switch wiring must be minimum 18-gauge (1 mm²) plenum rated, shielded (screened), twisted pair wire with a bare drain wire for grounding.
- ❑ Connect the shield (screen) wire [with a length less than 2" (50 mm)] to the shield (screen) ground terminal on the electric subpanel. Do not ground the shield (screen) wire on the humidistat or transmitter end.
- ❑ If you have a remote-mounted control cabinet, the water level control device, thermal trip, safety interlock, fill valve, and drain valve wiring must be minimum 18-gauge (1 mm²) stranded wire run in a conduit separate from power wires.

Do not use shielded (screened) cable for water level control devices.

FIGURE 7-1: VAPOR-LOGIC CONTROL BOARD DETAIL

Board detail showing white border

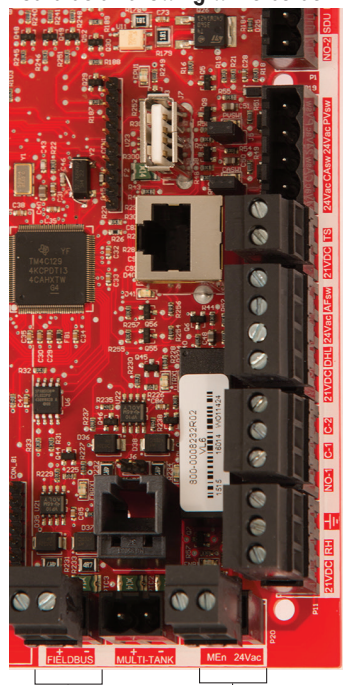

Field connection terminals. Terminals P-11 through P-16 have a white border on the Vapor-logic board. This is where you will make most of your field wiring connections.

For BACnet and modbus only.

Field connection terminals.

Pre-installation Checklist

FIGURE 8-1: VAPOR-LOGIC TERMINAL BLOCK DETAIL AND CONNECTION INSTRUCTIONS

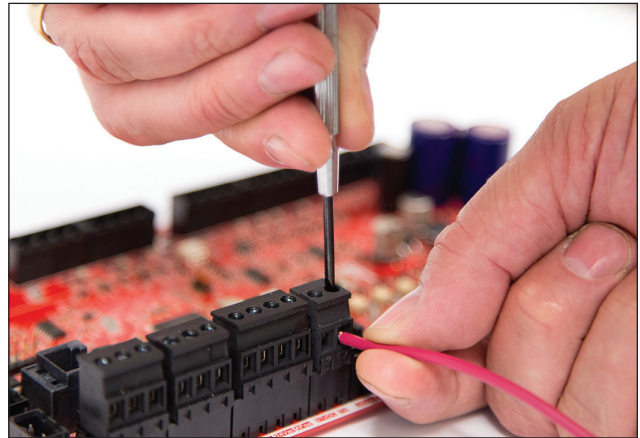
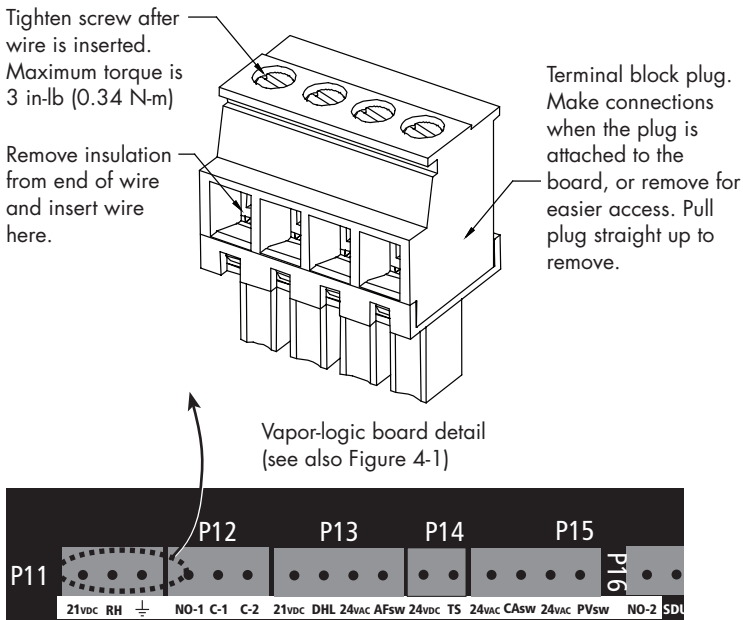

The Vapor-logic board is designed to make installation very easy:

- Terminal blocks that require field connections are outlined in white.
- Terminal plugs can be removed to allow easy access when inserting wires and tightening screws.
- For most applications, humidifiers ship with the control board fully configured, with drain, fill, and other humidifier components factory-wired to the board, and the keypad/display attached to the humidifier and connected to the Vapor-logic board.

Installation process

INSTALLING VAPOR-LOGIC IS A THREE-STEP PROCESS:

1. Connect field wiring from device to Vapor-logic board.

See instructions beginning on Page 10. Note that some connections listed here may not apply to your system.

- Control input (one required)
 - RH or dew point transmitter
 - Demand signal by others (4-20 mA or 0-10 VDC typical)
 - Room or duct humidistat
 - Demand signal by BACnet, Modbus, or LonTalk
- Communication connections
 - Vapor-logic keypad
 - Ethernet
 - Modbus
 - BACnet
 - LonTalk
 - Multiple-tank communication
- Programmable triac and relay
- Area-type, SDU dispersion fans, or steam blowers

2. Complete the Setup process.

See instructions beginning on Page 21.

3. Start up humidifier(s).

See instructions on Page 28.

Refer to the Pre-installation Checklist and drawings on the previous pages, and then make the field wiring connections as described on the following pages.

Step 1 – Field wiring: Control input

Connect control input signal wiring by inserting wires into Terminal P11 (labeled 21 vdc, RH, and ground) per the wiring diagram on the next page. Tighten screws.

Allowed inputs at Terminal P11 include:

- **RH transmitter or dew point transmitter**
Transmitters provide a signal proportional to the RH or dew point being measured. All transmitters provided by Anden are two-wire devices using a 4 to 20 mA signal.
- **Demand signal by others**
Demand signals are sent to the Vapor-logic board from another control system such as a building automation system. These systems have their own RH or dew point transmitters, calculate required humidifier output, and send a demand signal to the humidifier to create steam at a percentage of that humidifier's capacity. Demand signals are typically 0-10 VDC or 4-20 mA, but may also come from a DDC signal via Modbus, BACnet, or LonTalk.

A humidistat also delivers a demand signal to the humidifier, but it is not typically used with Vapor-logic.

Humidistats provide either on-off control or modulating control. Anden humidistats are powered by a 24 VDC supply provided by the Vapor-logic control board.

When using modulating control, the signal from a humidistat directly controls the amount of output from the humidifier.

Notes:

- See Figure 11-1.
- For more information about control input signal types and operation, see "On-off control" on page 12.
- See "Modbus and BACnet interoperability" on page 57 for more information about input signals.

FIGURE 10-1: TERMINAL P11

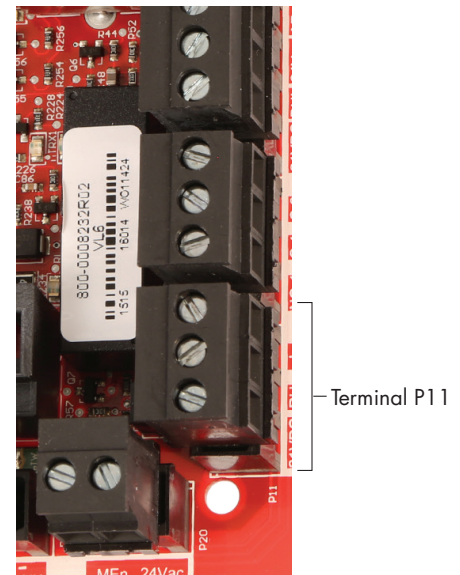

Terminal P11:

- 21 vdc = Power to space RH sensor
- RH = Space RH input (RH transmitter, humidistat, or demand signal by others (4-20 mA or 0-10) VDC input
- ⊕ = Ground for demand signal by others

Note:

If you do not know which control components were ordered with your system, contact Anden or connect your keypad/display to the Vapor-logic board per the instructions on Page 14. Go to the Setup menu per the instructions on Page 21 to view system parameters that were factory configured as ordered.

Step 1 – Field wiring: Control input

FIGURE 11-1: VAPOR-LOGIC CONTROL INPUT WIRING CONNECTIONS

Signal by others

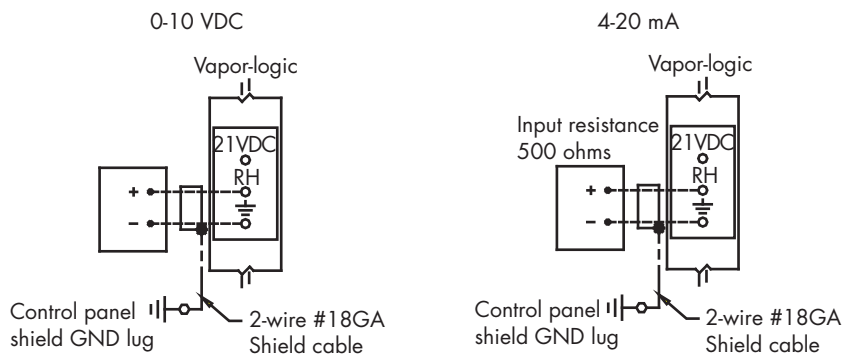

Transmitter

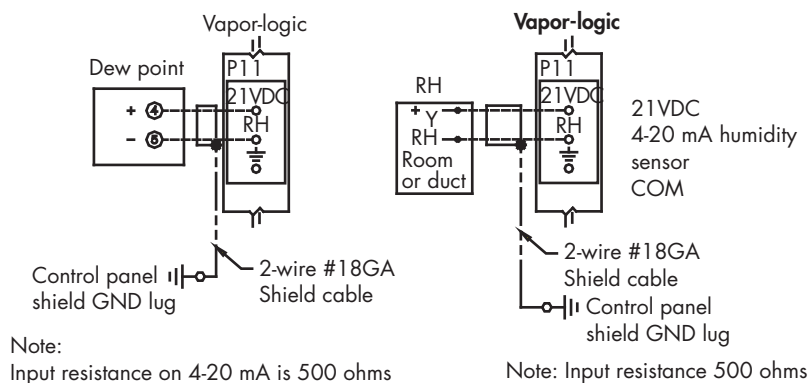

On-off RH humidistat

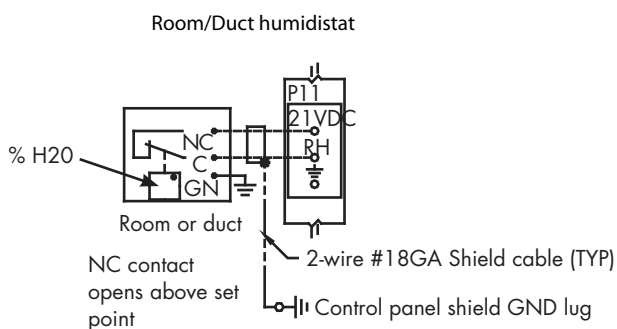

Key

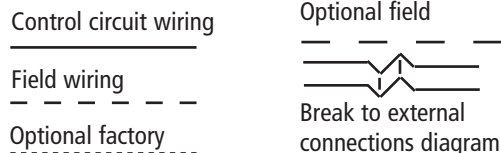

Step 1 – Field wiring: Control input signals

Anden offers three control options for all its humidification systems controlled by Vapor-logic: On-off control, demand signal control, and transmitter control. Transmitter for control is provided in the box.

ON-OFF CONTROL

On-off control—the simplest control scheme—does exactly what its name implies: the output device turns fully on, then fully off.

The humidistat that controls the humidifier has a differential between the on and off switch points. The differential is established at a range sufficient to prevent output short cycling. In other words, the humidity level has to fall below set point before the humidistat closes and energizes the humidifier. Once the humidifier is energized, the humidistat stays closed until the humidity is above set point. This creates an operating range that prevents the humidifier from running for very short periods of time.

Step 1 – Field wiring: Control input signals

MODULATING DEMAND SIGNAL CONTROL

With modulating demand signal control, a modulating humidistat or a building automation system sends a signal to the Vapor-logic controller, which then sends a signal to the humidifier to produce a directly proportional steam output. For example, if a humidistat operating between 4 mA and 20 mA sends a 4 mA signal, the humidifier produces no output; a 12 mA signal causes the humidifier to run at 50% of capacity; and a 20 mA signal causes the humidifier to run at 100% capacity.

With a humidistat provided by Anden producing this signal, the humidity set point is set at the humidistat. The keypad/display then is used for maintaining and troubleshooting the humidification system, with humidifier control stemming from the humidistat itself. With a building automation system (BAS) providing the signal, the humidity set point is established by the BAS, and the humidifier responds to the BAS commands.

TRANSMITTER CONTROL

With transmitter control, the Vapor-logic board receives a signal that corresponds to the actual humidity level measured in the space being controlled. (With a transmitter provided by Anden, the signal is 4 to 20 mA, which corresponds to 0 to 100% RH). The Vapor-logic controller employs an internal PID loop that uses this humidity measurement along with a user-defined humidity set point to calculate a demand level. This demand level is the level at which the humidifier will run. See "PID tuning" on Page 42.

Calculation of transmitter % RH

$$\% \text{ RH} = \frac{(\text{mA reading}) - 4 \text{ mA}}{16 \text{ mA}} \times 100\%$$

$$\text{Example: } \frac{12 \text{ mA} - 4 \text{ mA}}{16 \text{ mA}} \times 100\% = 50\% \text{ RH}$$

Step 1 – Field wiring: Limit controls

MAIN ENABLE INPUT (DRY CONTACT)

Connect wiring for an enable/disable dry-contact signal by inserting wires into the terminal block plug at P20 (labeled MAIN ENB). Tighten screws. Remove shunt on J402 if wiring is installed.

If an enable signal is not being used, jumper the MAIN ENB terminal block plug at P20 or attach the included shunt to the two pin header at J402.

FIGURE 14-1: TERMINAL P13

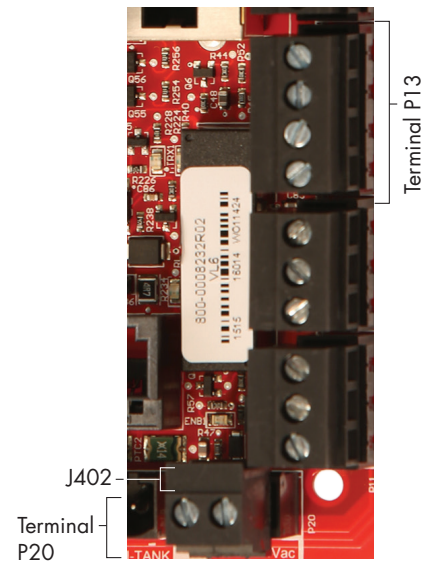

Terminal P13:
 21vdc = Power to duct high limit switch or transmitter
 DHL = Duct high limit switch/transm. (4-20 mA input)
 24vac = Power to airflow proving switch
 AFsw = Airflow proving switch (24 VAC input)

VAPOR-LOGIC KEYPAD/DISPLAY

If your keypad/display is factory-mounted and connected to the Vapor-logic board, proceed to installing the next device required by your system.

If your keypad/display was shipped loose, mount the keypad/display in a location so that the provided cable is long enough to connect the keypad/display to the Vapor-logic board.

To connect a Vapor-logic keypad/display to the Vapor-logic board, insert the male end of the provided cable into the Vapor-logic board at Terminal P10 (labeled Display) until you hear a click sound (see also the wiring diagram on the next page). Plug the other end of the cable into the keypad/display. This connection provides DC power and communication to the keypad/display.

FIGURE 14-2: TERMINAL P10

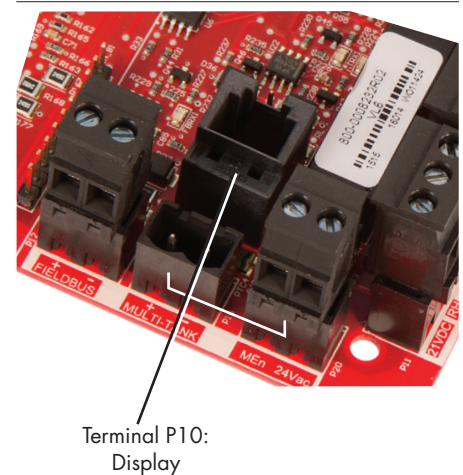

Step 1 – Field wiring: Communication connections

FIGURE 15-1: VAPOR-LOGIC COMMUNICATION WIRING CONNECTIONS

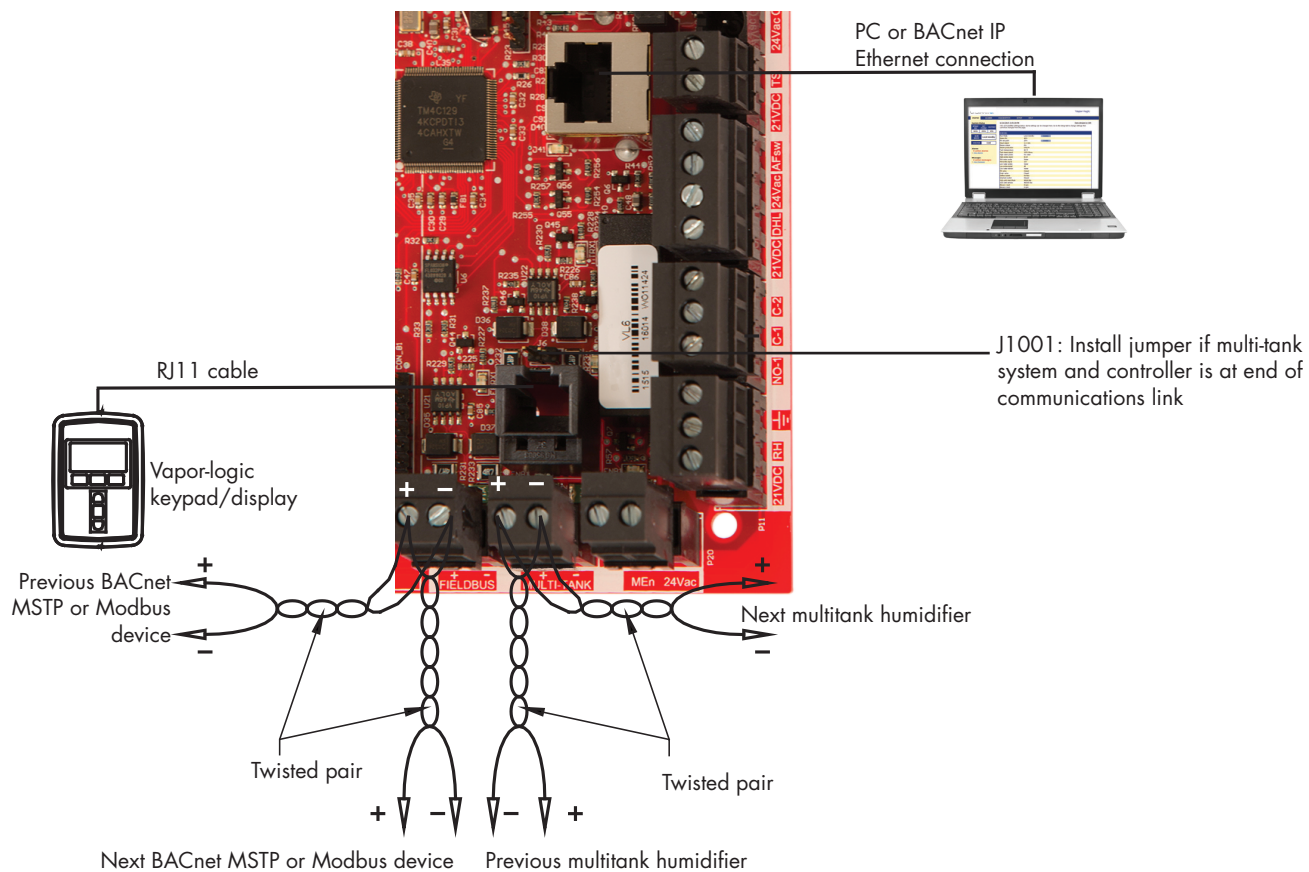

Step 1 – Field wiring: Communication connections

WEB INTERFACE COMMUNICATION

Utilizing the Vapor-logic Web interface is optional. The humidifier can be operated using the keypad/display and/or the Web interface. When using the Web interface, the humidifier can be accessed by a computer either directly or through a network. Each Vapor-logic controller ships with the static IP address of **192.168.1.195**. This allows users to locate the Web interface upon start-up. After initial start-up, the IP address can remain as is, be re-assigned as another static address, or configured to automatically go out and find an IP address on the network using DHCP. See the steps below for information about connecting to the humidifier using the Web interface.

CONNECTING WEB INTERFACE DIRECTLY TO A COMPUTER NOT ON A NETWORK

1. Connect the Ethernet cable.

Insert the male end of an RJ45 Ethernet cable into the Vapor-logic board at P9 (labeled Ethernet; see Figure 16-1) until you hear a click sound. Insert the other end of the cable into a computer. Since the Ethernet port on the Vapor-logic board is auto-sensing, either a straight-through or crossover cable will work.

2. Check the current IP address of your computer.

Connecting a computer to the humidifier requires that the computer being used has the same network address range as Vapor-logic. In order to validate this, check the IP address of the computer being used by going to the computer's Start menu and selecting Run. When the box shown below appears, type in **cmd** on the Open line and hit OK.

FIGURE 16-1: TERMINAL P9

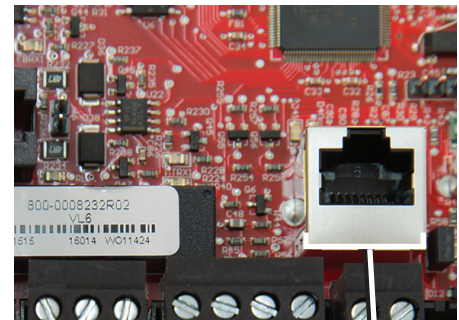

Terminal P9:
Ethernet

FIGURE 16-2:
CHECKING YOUR IP ADDRESS

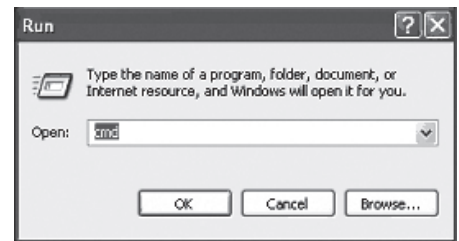

Vapor-logic default IP address
192.168.1.195

Step 1 – Field wiring: Communication connections

After a system prompt appears, type in **ipconfig** and then hit Enter. The current IP address of the computer should appear. If the first three segments of that IP address are different than the first three segments of the humidifier’s default IP (192.168.1.xxx), you must change either your computer or Vapor-logic’s IP address such that they match each other.

FIGURE 17-1: CHECKING YOUR IP ADDRESS

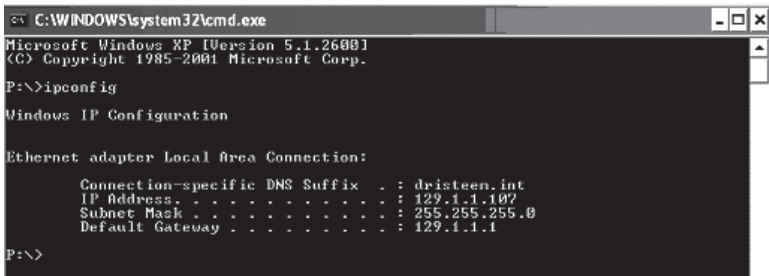

```

C:\WINDOWS\system32\cmd.exe
Microsoft Windows XP [Version 5.1.2600]
(C) Copyright 1985-2001 Microsoft Corp.

P:\>ipconfig

Windows IP Configuration

Ethernet adapter Local Area Connection:

    Connection-specific DNS Suffix . : dristeen.int
    IP Address . . . . . : 129.1.1.107
    Subnet Mask . . . . . : 255.255.255.0
    Default Gateway . . . . . : 129.1.1.1

P:\>
  
```

3. **Change the IP address of your humidifier or computer if necessary.**
 - a. **Change the IP address of the humidifier to work with your computer.**

The most straightforward way to change the IP address of the humidifier using Vapor-logic is to use the keypad/display. Go to Setup/Communications/Network IP address on the keypad/display and change the IP address such that the first three segments of the computer’s settings match the network address. Make sure the last digit of the IP address is different between the humidifier and the computer. Cycle power of Vapor-logic board for address change to take effect.
 - b. **Change the IP address of your computer to match the humidifier.**

Changing the IP address of the computer being used will likely require administrative privileges for your company’s network. Please consult your IT department for this task.

Step 1 – Field wiring: Communication connections

4. Connect to the humidifier.

- a. Using a computer connected to the Vapor-logic board, open a Web browser such as Mozilla® Firefox® or Internet Explorer®.
- b. Find the browser address bar (see Figure 23-1), delete all existing text in the browser address bar, type the Vapor-logic IP address into the browser’s address bar, and press Enter.

Note: The Vapor-logic default IP address is **192.168.1.195**

CONNECTING WEB INTERFACE TO AN ETHERNET NETWORK

See Caution at right before proceeding.

If your network uses DHCP (Dynamic Host Configuration Protocol), use the keypad/display to navigate to:

Setup/Communications/Network IP Address. Enable DHCP and restart the Vapor-logic board.

The most current IP address can always be found by using the keypad/display to navigate to:

Set-Up/Communications/Network IP Address.

Important: DHCP cannot be enabled from the Web interface; it must be enabled using the keypad/display.

OTHER COMMUNICATION CONNECTIONS

For BACnet or LonTalk installation instructions, see Page 57.

FIGURE 18-1: ENTERING THE IP ADDRESS



CAUTION

Vapor-logic IP address

Before you connect a Vapor-logic device to a network, please contact your IT department. Given that the Vapor-logic controller ships with a static IP address, it is important to ensure that there is not another device with that same IP address already on the network. Working with your IT department before network connection will help ensure the integrity of the network and the devices on that network

DHCP and IP address

When DHCP is enabled, the server can dynamically change the IP address of Vapor-logic, making existing bookmarks unusable.

Step 1 – Field wiring

PROGRAMMABLE RELAYS (DRY CONTACT)

See “Programmable relay maximum current” in Caution below.

See Figure 19-1. Connect wiring for remote signaling using a programmable relay (dry contact) by inserting wires into the terminal block plug at P12 or P16, per the wiring diagram in Figure 19-1. Tighten screws.

This connection allows remote activation of devices such as fans, signal lights, and alarms. Output parameters are defined during Step 2 of the installation process.

CAUTION
Programmable relay maximum current
Programmable relay (dry contact) (P12) is rated for 125 VAC, 3 AMP or 30 VDC, 3 AMP maximum. Exceeding this maximum rating can cause the relay component or the Vapor-logic board to fail.

FIGURE 19-2: VAPOR-LOGIC PROGRAMMABLE RELAY WIRING CONNECTIONS

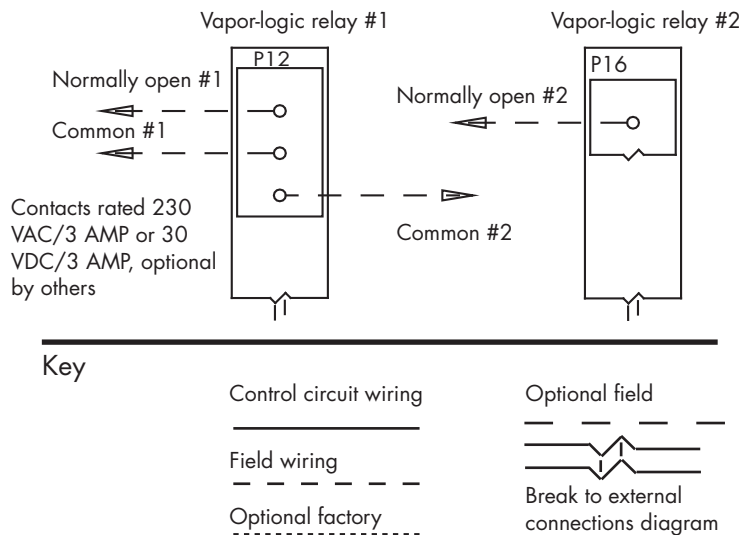

FIGURE 19-1: TERMINAL P12 AND P16



Terminal P16:
 NO-2 = Relay 2, normally open
 PV/CA = Power vent/combustion air control signal (24 vac output)
 SDU = Space Distribution Unit (24 vac output)

Terminal P12:
 Programmable relay (dry contact)
 NO-1 = Relay 1, normally open
 C-1 = Common 1
 C-2 = Common 2

Step 1 – Field wiring: Sensor placement

HUMIDISTAT AND SENSOR LOCATIONS ARE CRITICAL

Humidistat and sensor location have a significant impact on humidifier performance. In most cases, do not interchange duct and room humidity devices. Room humidity devices are calibrated with zero or little airflow; whereas duct humidity devices require air passing across them.

Recommended sensor locations (see Figure 20):

- A Ideal. Ensures the best uniform mix of dry and moist air with stable temperature control if HVAC is running constantly.
- B Ideal. Mounted centrally above the canopy in an area shielded from water, light and heat sources
- C Acceptable (behind wall or partition) for sampling entire room if sensor is near an air exhaust return outlet. Typical placement for sampling a critical area.
- D Not acceptable. These locations may not represent actual overall conditions in the space.
- E Not acceptable. Do not place sensors near windows, door passageways, or areas of stagnant airflow.

Other factors affecting humidity control

Humidity control involves more than the controller's ability to control the system. Other factors that play an important role in overall system control are:

- Size of humidification system relative to load
- Overall system dynamics associated with moisture migration time lags
- Accuracy of humidistats and humidity transmitters and their location
- Dry bulb temperature accuracy in space or duct
- Velocities and airflow patterns in ducts and space environments
- Electrical noise or interference

FIGURE 20-1: RECOMMENDED SENSOR LOCATION

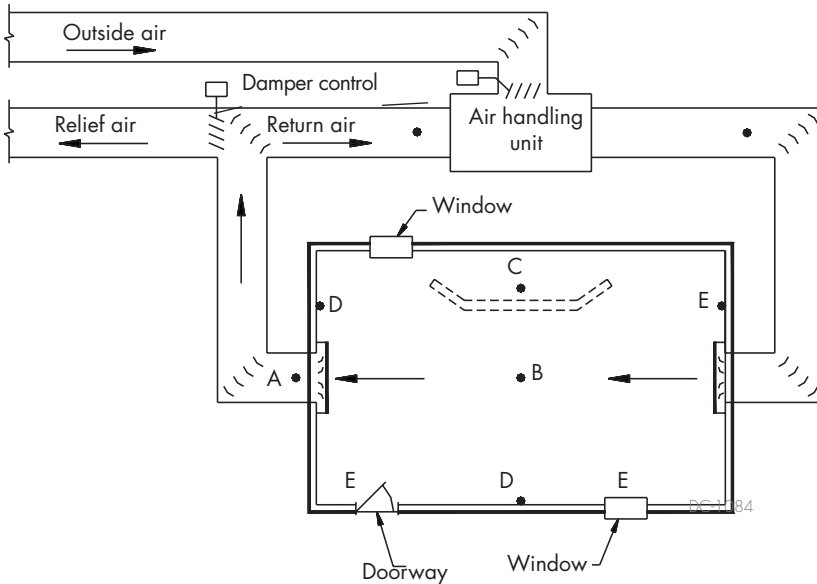

Step 2 – Setup

To simplify the field-installation process, humidifiers are sent from the factory with standard configuration. However, some settings are unknown at the factory and need to be defined during the setup process using the Setup menu. The Setup menu is also where you make future system setting changes.

To begin the field setup process, go to the Setup menu on either the keypad/display or the Web interface. Setup menu parameters are listed in Table 23-1. Options and defaults are the same whether viewed from the keypad/display or Web interface. However, labels may be abbreviated on the keypad/display.

USING THE KEYPAD/DISPLAY

To access the Setup menu on the keypad/display, press the Main softkey on the Vapor-logic keypad (see figure below). Press the Down arrow on the keypad until Setup is highlighted. Press Enter.

After entering the Setup menu, press the Up and Down arrows to scroll through all setup parameters or to change values. Use the Enter key to select parameters.

FIGURE 21-2: USING THE VAPOR-LOGIC KEYPAD

Typical Home screen

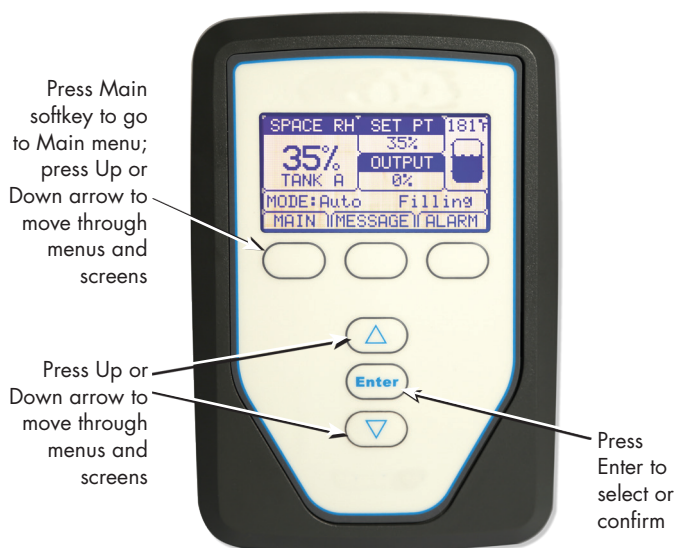
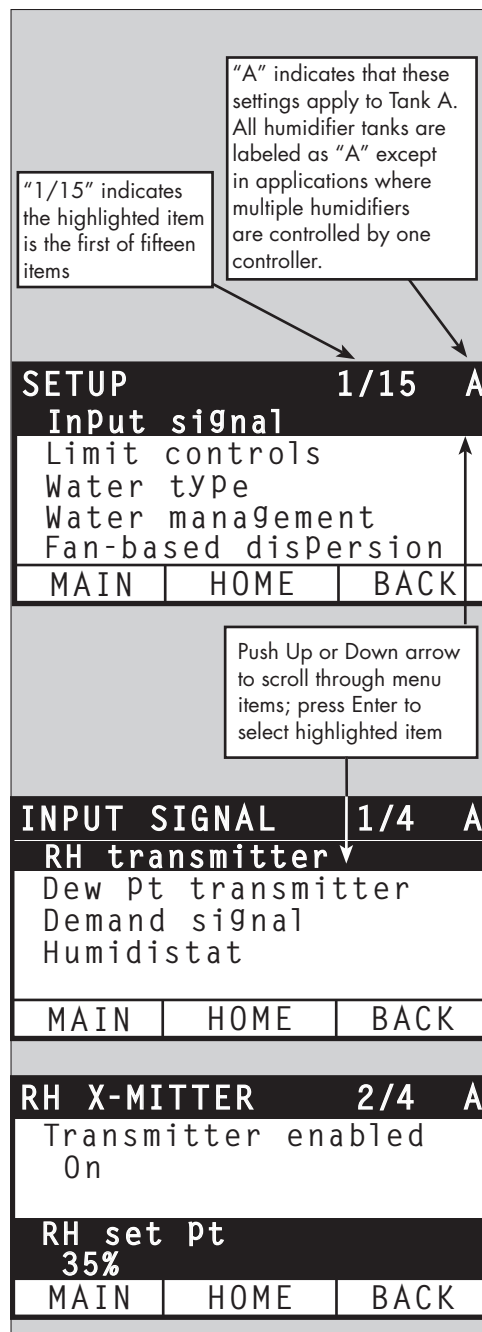

FIGURE 21-1: KEYPAD/DISPLAY SCREENS



Step 2 – Setup

USING THE WEB INTERFACE

Although not required for humidifier operation, the Web interface allows convenient and remote access to Vapor-logic.

See Page 16 for Web interface connection and IP address instructions. Follow the instructions below to complete the setup process.

FIGURE 22-1: USING THE VAPOR-LOGIC WEB INTERFACE (SETUP SCREEN SHOWN)

Click on a tab label to move to another screen

STATUS **ALARMS** **DIAGNOSTICS** **SETUP** **HELP**

System Status

DEMAND	OUTPUT
73.3%	0%

RUN MODE **Auto**

TANK STATUS **Idle**

Alarms
0 active alarms
[View Alarms](#)

Messages
1 active message
[View Messages](#)

Click here to view alarms

Click here to view messages

Click on label to contract (-) or expand (+) menu item

Tuesday, May 22, 2012 4:30:14 PM **Data stream is LIVE**

Set or change all humidifier settings below. Humidifiers are sent from the factory configured as ordered. However, some settings are unknown at the factory and need to be defined on this page.

SETUP

- + INPUT SIGNAL
- + LIMIT CONTROLS
- WATER MANAGEMENT
 - End of season drain
 - EOS enabled Yes **CHANGE**
 - Idle time for EOS 72 hours **CHANGE**
 - Service interval
 - Service interval 300 **CHANGE**
- + FAN-BASED DISPERSION
- + COMMUNICATIONS
- + PROGRAMMABLE OUTPUTS
- + SET DATE AND TIME
- + LANGUAGE
- + UNITS
- + SECURITY
- + CAPACITY ADJUST
- + RESET TO DEFAULTS

Click on CHANGE to change value

To change value: Highlight value; type in new value; click on APPLY

Step 2 – Setup

**Table 23-1:
Setup menu**

Menu item	Default value	Minimum value	Maximum value	Units	Notes
Note: Your system might not have all of the items listed in this table (Pages 23 through 36).					
TDS settings (not available in Europe)					
High TDS causes?	Alarm and message	Message only	Alarm and message	-	Alarm will occur at 75 ppm if configured to alarm for High TDS. Message will occur at "TDS message setpoint" setting.
TDS message setpoint	50	25	75	-	
Input signal					
RH transmitter					
Transmitter enabled	-	No	Yes	-	
RH set point	35	0	100	%	
RH offset	0	-20	20	%	Anden recommends using default values for offsets and PID settings when first setting up your humidifier.
PID tuning	-	-	-	-	
RH PID band	10	0	50	%	
Proportional gain	80	0	1000	-	
Integral gain	40	0	1000	-	
Derivative gain	0	0	1000	-	
Dew pt transmitter					
Transmitter enabled	-	No	Yes	-	
Dew point set point	50	20	80	°F	
	10	-6	26	°C	
Dew point offset	0	-20	20	°F	Anden recommends using default values for offsets and PID settings when first setting up your humidifier.
	0	-11	11	°C	
Dew point minimum	0	-100	Maximum	°F /°C	
Dew point maximum	100	Minimum	100	°F /°C	
PID tuning	-	-	-	-	
Dew point PID band	10	1	20	°F	
	5	1	20	°C	
Proportional gain	80	0	1000	-	
Integral gain	40	0	1000	-	
Derivative gain	0	0	1000	-	

Continued

Step 2 – Setup

Table 24-1:
Setup menu (continued)

Menu item	Default value	Minimum value	Maximum value	Units	Notes
Demand signal	-	-	-	-	
VDC signal	-	-	-	-	
VDC signal enabled	-	No	Yes	-	
0% output at	1.0	0.0	Maximum	VDC	
100% output at	9.0	Minimum	10.0	VDC	
mA signal	-	-	-	-	
mA signal enabled	-	No	Yes	-	
0% output at	4.0	0.0	Maximum	mA	
100% output at	20.0	Minimum	20.0	mA	
Control via Modbus	-	-	-	-	Choose Modbus, BACnet, or LonTalk in this section only if your demand input signal is via Modbus, BACnet, or LonTalk. If you are interoperating (sharing operating parameters with a building automation system) using Modbus, BACnet, or LonTalk protocols, see also the Communications Setup options.
Modbus controlled	No	No	Yes	-	
Control via BACnet	-	-	-	-	
BACnet controlled	No	No	Yes	-	
Control via LonTalk	-	-	-	-	
LonTalk controlled	No	No	Yes	-	
Humidistat	-	-	-	-	
Humidistat enabled	No	No	Yes	-	
Limit control					
HL switch	-	-	-	-	
Switch in system	Yes	No	Yes	-	
HL transmitter	-	-	-	-	
Transmitter enabled	No	No	Yes	-	
Duct HL set point	80	5	95	% RH	
Duct HL span	5	0	20	% RH	Span (throttle span) is an offset below the high limit set point where the humidifier reduces output but does not turn off until the device high limit set point is reached.
Duct HL offset	0	-20	20	% RH	

Continued

Step 2 – Setup

**Table 25-1:
Setup menu (continued)**

Menu item	Default value	Minimum value	Maximum value	Units	Notes
Water management (continued)					
Service interval	-	-	-	-	
Service interval	Model-specific	0	2,200,000	lbs	Select amount of water to be converted to steam or hours that humidifier runs before service interval is reached.
	Model-specific	0	1,000,000	kg	
	Model-specific	0	10,000	Hours	
Probe threshold	-	-	-	-	
Probe threshold	800	300	8000	-	See probe signal description in status chart.
Probe debounce time	2	1	10	Seconds	Amount of time the water probe must be in or out of water to change the water/no water state.
Fill fault time	40	40	250	Minutes	Amount of fill time before an alarm will occur.
AS150 management					
Mini drain	No	No	Yes	-	Contactors are on during draining. May provide more stable output steam.
Tempering enabled	Model-specific	No	Yes	-	Enables drain tempering for AS150. Tempering turns on the fill valve whenever the drain is energized and may not be required if the drain line can accommodate boiling water.
TP Mode enabled	Model-specific	No	Yes	-	TP Mode allows the humidifier to more closely track demand by cycling the contactor when current is greater than the demand signal requirement.
Turn on percent	20	10	20	%	Minimum run level when TP mode is disabled.
Left cylinder drain	Closed	Closed	Open	-	Force specific drain to open
Right cylinder drain	Closed	Closed	Open	-	Force specific drain to open
Disable left cylinder	No	No	Yes	-	Disables specific cylinder
Disable right cylinder	No	No	Yes	-	Disables specific cylinder
Clear foaming fault	Yes	No	Yes	-	Auto clearing of foaming fault
Pulse fill mode	No	No	Yes	-	
Fan-based dispersion					
Changing fan-based dispersion settings can require component changes for system to operate correctly.					
SDU on system	-	No	Yes	-	An SDU is a space distribution unit, which disperses steam using a fan housed in a cabinet.
Area-type on system	-	No	Yes	-	An Area-type dispersion unit is a caged fan mounted on top of the humidifier tank.
Output time delay	5	1	30	Minutes	Select number of minutes fan-based dispersion unit operates after water in tank stops boiling. A delay keeps the fan running until all steam is dispersed.

Continued

Step 2 – Setup

Table 26-1:
Setup menu (continued)

Menu item	Default value	Minimum value	Maximum value	Units	Notes
Communications					Changing communications settings can require component changes for system to operate correctly.
BACnet	-	-	-	-	
Unlock code	0	0	999999	-	
BACnet enabled	-	No	Yes	-	
BACnet comm channel	19200MS/TP	BACnet IP	76800 MS/TP	-	
Device instance	255	0	4194303	-	
MS/TP station	1	0	127	-	MS/TP only
Max mains	127	0	127	-	MS/TP only
Max info frames	1	1	127	-	
UDP port (47808)	47808	1024	65535	-	BACnet/IP only
Modbus	-	-	-	-	
Modbus enabled	-	No	Yes	-	
Modbus baud rate	9600	4800	38400	-	
Modbus address	99	0	255	-	
LonTalk	-	-	-	-	
LonTalk enabled	-	No	Yes	-	
Network IP address	-	-	-	-	
Network IP address	192.168.1.195	0.0.0.0	255.255.255.255	-	
Network IP mask	255.255.255.0	0.0.0.0	255.255.255.255	-	
Network gateway	192.168.1.1	0.0.0.0	255.255.255.255	-	
Enable DHCP	No	No	Yes	-	Use keypad/display to access this menu item. This item is not available when using the Web interface.
Programmable outputs					
Dry contact 1 or 2	-	-	-	-	CAUTION Programmable dry contact maximum current Programmable dry contact (P12 or P16) is rated for 125 VAC, 3 AMP or 30 VDC, 3 AMP maximum. Exceeding this maximum rating can cause the dry contact (relay) component or the Vapor-logic board to fail.
Default alarms	Yes	No	Yes	-	A dry contact activates whenever there is an alarm, which does not auto-clear.
Selected alarms/messages	No	No	Yes	-	A dry contact activates whenever there are alarms or messages selected from the setup list.
Heat on-off enabled	No	No	Yes	-	A dry contact activates when the humidifier is heating.
Steam yes-no enabled (not an AS150 menu item)	No	No	Yes	-	A dry contact activates when the tank temperature reaches boiling.
Contact behavior	Normally open	Normally open	Normally closed	-	Contact action on event.

Continued

Step 2 – Setup

Table 27-1: Setup menu (continued)					
Menu item	Default value	Minimum value	Maximum value	Units	Notes
Set date and time					
Date	-			mm/dd/yy	
Time	-	0:00	23:59	Hours:Minutes	24 hour clock
Language					
Display in English	-	No	Yes	-	Select one language for both keypad/display and Web interface communications.
Display in French	-	No	Yes	-	
Display in German	-	No	Yes	-	
Display in Spanish	-	No	Yes	-	
Display in Dutch	-	No	Yes	-	
Units					
Display inch-pound	-	No	Yes	-	
Display SI	-	No	Yes	-	
Security					
Require password	No	No	Yes	-	
Set password	None	0	9999	-	Enter a four-digit password using numbers only.
Time-out	5	1	120	Minutes	The number of inactivity minutes Vapor-logic remains in read-write mode before returning to read-only mode
Capacity adjust					
Capacity calibration (GTS systems)	100.0	0.0	245.0	%	Changing the capacity calibration setting changes reported, not actual, humidifier output.
Capacity calibration (AS150 systems)	100.0	10.0	100.0	%	Changing the capacity setting changes the actual humidifier output.
Idle time					
Idle time	5	1	120	Minutes	Select number of minutes keypad/display remains idle before returning to the Home screen.
Reset to defaults					CAUTION These actions cannot be reversed
Reset to defaults	-	-	-	-	Select this if you want to reset all humidifier settings to factory defaults
Reset ignitor counts?	-	-	-	-	Select this if you want to reset the GTS ignitor counts.
Valve span					
Span	Min 2.00 Max 10.00	0.00	10.00	VDC	

Step 3 – Startup

To start up your humidifier, go to the Start-up Checklist in your humidifier’s Installation, Operation, and Maintenance manual.

STAGING MULTIPLE AS150 HUMIDIFIERS

Up to four AS150 electrode steam humidifiers can be staged to operate in sequence. In a sequenced application, one control input signal is divided by user-selectable settings among the humidifiers connected in sequence. See the Vapor-logic board connection points in Figure 28-1.

CONTROL INPUT EXAMPLES

Table 37-1:
Control input example for four AS150 humidifiers in sequence

AS150 humidifier	Control input	Result
H-1 (primary)	Any valid Vapor-logic control input	0 to 100% steam output corresponding to 4–20 mA or 0–10 VDC control signal
H-2 (staged)	4–6 VDC*	0 to 100% steam output scaled across 4–6 VDC range
H-3 (staged)	6–8 VDC*	0 to 100% steam output scaled across 6–8 VDC range
H-4 (staged)	8–10 VDC*	0 to 100% steam output scaled across 8–10 VDC range

* User-selectable, 0–10 VDC in 0.1V increments.

Table 37-2:
Control input example for two AS150 humidifiers in sequence

AS150 humidifier	Control input	Result
H-1 (primary)	Any valid Vapor-logic control input	0 to 100% steam output corresponding to 4–20 mA or 0 to 10 VDC control signal
H-2 (staged)	5–10 VDC*	0 to 100% steam output scaled across 5–10 VDC range

* User-selectable, 0–10 VDC in 0.1V increments.

SETTING CONTROL INPUT RANGES

- Using the keypad/display or Web interface, go to the Tank setup menu, then select Input signal, then Demand signal.
- Select Yes to enable user input.
- Scroll down to select the range for each staged input.
- Press the Enter key to confirm selections.

Multi-tank mode

Note: The Anden AS150 humidifier does not operate in multi-tank mode.

FIGURE 28-1: VAPOR-LOGIC BOARD CONNECTIONS FOR STAGING MULTIPLE AS150 HUMIDIFIERS

Primary AS150 humidifier (H-1) board

Corner of Vapor-logic board opposite from Ethernet connection shown

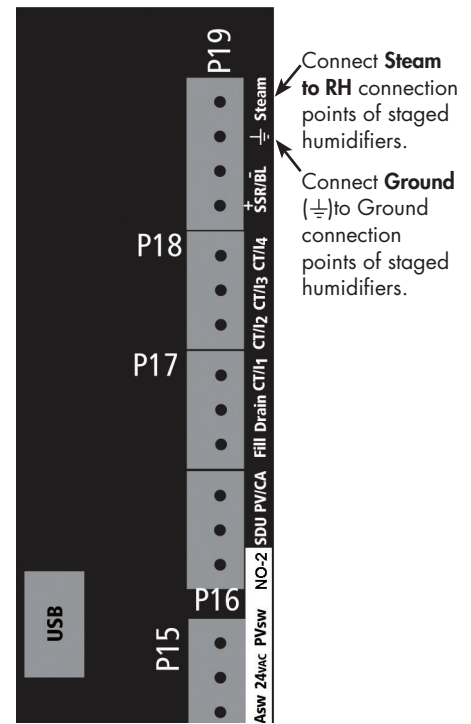

Contact Anden if you need assistance staging AS150 humidifiers. See “Calling Anden Technical Support” on Page 67.

Using menus and screens

VAPOR-LOGIC KEYPAD/DISPLAY HAS THE FOLLOWING MENUS AND SCREENS:

- Home screen
- Main menu, and four submenus:
 - Status
 - Diagnostics
 - Alarms
 - Setup

Press the Main softkey to go to the Main menu selection screen. Press the Up and Down arrow keys to choose a submenu and press Enter to select.

Vapor-logic Web interface has the following screens:

- Status
- Diagnostics
- Alarms
- Setup
- Help

FIGURE 29-1: USING THE KEYPAD/DISPLAY

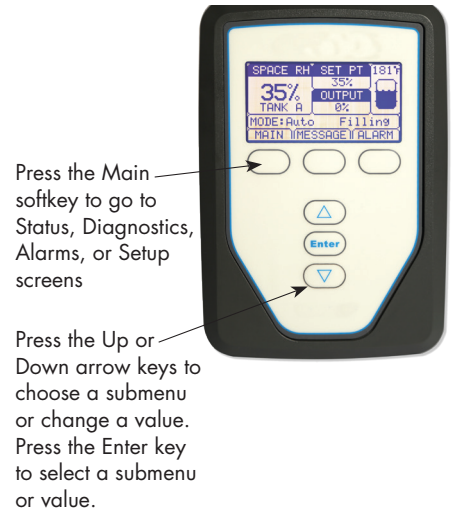
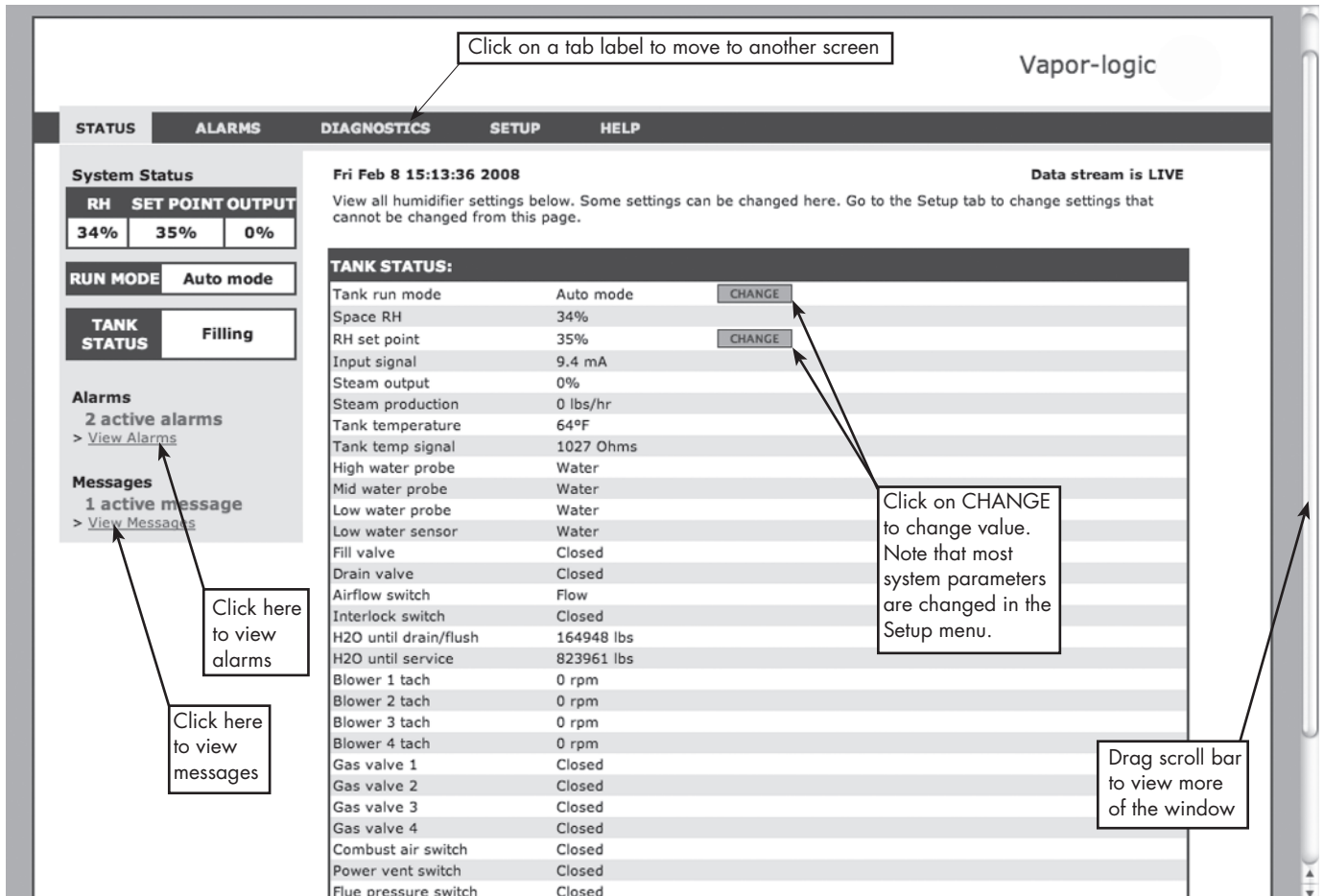

FIGURE 29-2: USING THE VAPOR-LOGIC WEB INTERFACE (STATUS SCREEN SHOWN)



Home screen (keypad/display)

Click on tab labels to go to other screens. The highlighted tab indicates the current screen.

Vapor-logic returns to the Home screen on the keypad/display after a user-defined period of idleness. The Home screen displays the items most frequently viewed: Actual space RH, tank/system output or steam demand, humidifier mode, and tank activities such as filling, skimming, heating, boiling, and draining.

There is a tank level indicator on the right side of the screen. See the table below for a description of tank level indicators.

Above the tank level indicator is a tank temperature display showing actual tank temperature.

CHANGING MODE AND SET POINT

Mode and Set point can be changed from the Home screen. Press the Up or Down arrow key until the Set point or Mode is highlighted, press Enter, press Up or Down arrow key to change value, press Enter to confirm. All other parameters shown on the Home screen are for viewing only and cannot be changed. Go to the Setup menu to change these items.

TANK ACTIVITIES DEFINED

- **Filling:** Fill valve remains open until water reaches operating level.
- **Skimming:** Fill valve is open to allow water to flow through the overflow port, skimming off precipitated minerals (tap and softened water systems only).
- **Draining:** Tank is draining.
- **Flushing:** Fill and drain valve are open to flush tank.
- **Heating:** Water in tank is heating.
- **Boiling:** Water in tank is boiling and there is a demand for humidity.
- **Hot:** Water is at boiling temperature and there is no demand for humidity.
- **Warm:** Water temperature is equal to or greater than 100 °F (38 °C) and not boiling.
- **Cold:** Water temperature is less than 100 °F (38 °C).
- **EOS drain:** Humidifier is in end-of-season drain.
- **Empty:** There is no water in the humidifier and there is no demand for humidity.
- **Idle:** No demand or an active alarm preventing operation.
- **TmpDrain:** Humidifier is doing a drain to reduce conductivity or eliminate foam. Process can take several minutes for large-capacity humidifiers.
- **Full:** Water level has reached top of cylinder.

FIGURE 30-1:
KEYPAD/DISPLAY HOME SCREEN

SPACE RH	SET PT	212°F
34%	35%	
TANK A	OUTPUT	
	59%	
MODE: Auto		Filling
MAIN	MESSAGE	ALARM

Status screen

Using either the keypad/display or the Web interface, the Status screen is where all humidifier parameters can be viewed.

See the tables on the following pages for Status screen item descriptions for both the keypad/display and Web interface.

FIGURE 31-2: WEB INTERFACE STATUS SCREEN

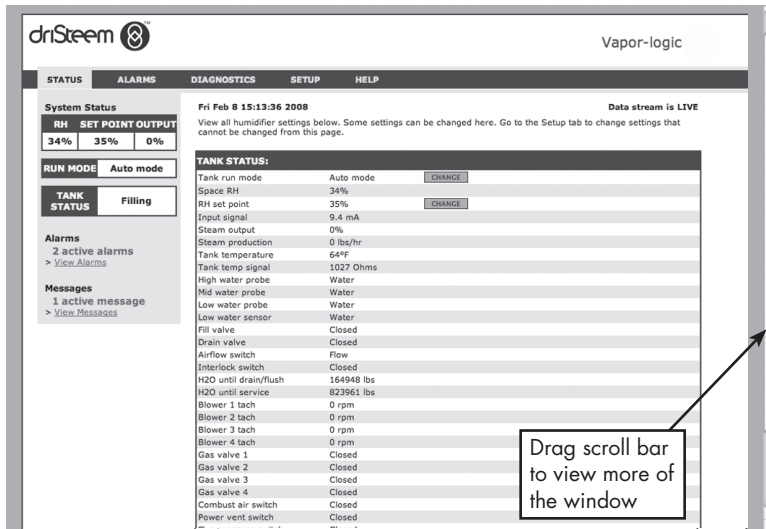
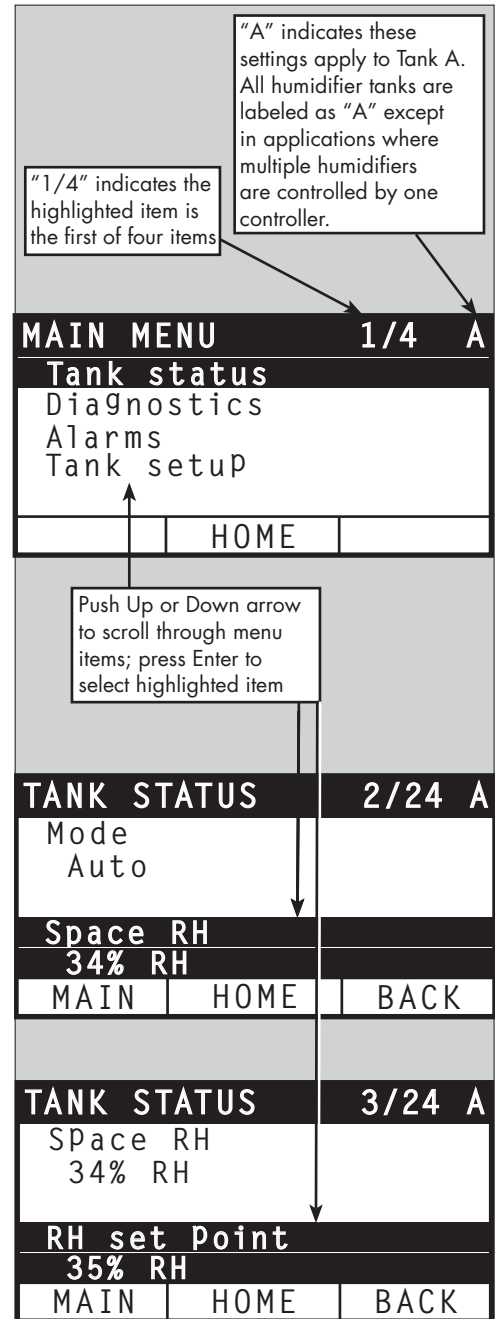

FIGURE 31-1: KEYPAD/DISPLAY SCREENS



Status screen

Table 32-1:
Status screen

Note: Your system might not have all of the items listed in this table (Pages 32 and 42).

Menu item	Default value	Minimum value	Maximum value	Units	Notes
Mode	Standby	-	-	-	<p>Operating mode of humidifier. Choose from Auto, Standby, or Drain.</p> <ul style="list-style-type: none"> In Auto mode, the humidifier operates normally. All humidifier components are monitored and controlled. If there is a call for humidification, the system reacts. In Standby mode, the humidifier is offline. All humidity control inputs appear but are not acted upon; however, if the tank temperature falls below the freeze protect set point, the drain valve opens. In Drain mode, the automatic drain valve (if so equipped) opens and the tank drains. All humidifier operation is suspended, and the drain valve remains open until the unit is taken out of Drain tank mode. See the Diagnostics section for information about Test outputs and Test run modes.
Space RH	-	0	100	%	
RH set point	35	0	100	%	
Input signal	-	0	10	VDC	
	-	0	20	mA	
Dew point	-	0	100	°F	
	-	-17	37	°C	
Dew point set point	50	20	80	°F	
	10	-6	26	°C	
Storage pressure	-	0	100	psi	
TDS	-	0	9999	ppm	
Inlet pressure switch	-	No water	Water	-	
Steam demand	-	0	100	%	Displays steam demand as a percent of capacity
Steam output	-	0	100	%	Displays steam output as a percent of capacity
Steam production	-	0	100,000	lbs/hr	
	-	0	100,000	kg/h	
Duct RH	-	0	100	%	
Duct HL switch	-	Open	Closed	-	
Duct HL set point	80	5	95	%	
Duct HL signal	-	0	20	mA	
Tank temperature	-	-30	275	°F	
	-	-34	135	°C	
Tank temp signal	-	0	2200	Ohms	
Aux temperature	-	-20	160	°F	
	-	-29	71	°C	
Aux temp signal	-	0	26	mA	

Continued

Status screen

Table 41-1: Status screen (continued)					
Menu item	Default value	Minimum value	Maximum value	Units	Notes
Board voltage	24	0	30	VAC	
Board temp	-	0	200	°F	
Interlock switch	-	Open	Closed	-	
Water until service	-	-	2,200,000	lbs	Displays amount of water to be converted to steam before next recommended maintenance service
	-	-	1,000,000	kg	
Pump hours	-	0	1,000,000	hours	
Hours until service	-	0	10,000	hours	
Lifetime hours	-	0	100,000	hours	
Current	-	0	Model dependent	Amps	
High water probe	-	No water	Water	-	

Diagnostics screen

The Diagnostics screen provides access to system messages, system data, humidifier information, and test functions.

See the following pages for more information about the Diagnostics screen.

SYSTEM MESSAGES AND THE MESSAGES LOG

When a system event occurs (e.g., when regularly scheduled unit servicing becomes due), a system message is added to the Messages Log (“Service unit”). The Messages Log displays the message name, date and time of occurrence, plus whether the message is active, has been cleared by an operator, or auto-cleared by Vapor-logic. Active messages display first in the Messages Log, followed by cleared messages, listed in order of occurrence. The Messages Log displays up to ten messages. As new messages enter the log, the oldest, cleared messages leave the log first.

Messages auto-cleared by Vapor-logic describe events that have resolved on their own. For example, a “No airflow” message appears when there is no airflow in the duct. If airflow returns, the “No airflow” message auto-clears, but stays in the Messages Log (per the rules described above) to let the operator know there was an airflow interruption.

The keypad/display highlights the Message softkey label when there is a system message. When this occurs, press the Message softkey to view the Messages Log.

The Web interface displays a link to system messages in the upper left corner of the screen. Click on the link to view system messages (see the next page).

See Pages 51 through 56 for more information about downloading data, USB backup and restore, and test modes.

FIGURE 34-1: KEYPAD/DISPLAY SCREENS

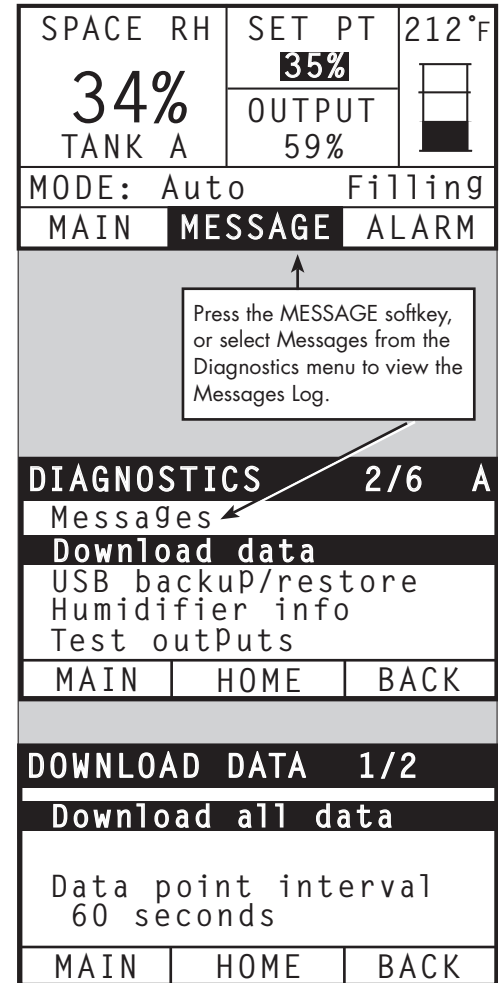

Diagnostics screen

FIGURE 35-1: VAPOR-LOGIC WEB INTERFACE DIAGNOSTICS SCREEN

Vapor-logic

STATUS ALARMS DIAGNOSTICS SETUP HELP

System Status
RH SET POINT OUTPUT
 34% 35% 0%

RUN MODE Auto mode

TANK STATUS Filling

Alarms
 2 active alarms
 > View Alarms

Messages
 1 active message
 > View Messages

Fri Feb 8 15:13:36 2008 **Data stream is STOPPED** START LIVE DATA

View system data and humidifier information, or test humidifier operation on this page.

DIAGNOSTICS

+ DOWNLOAD DATA

- USB BACKUP/RESTORE

Backup settings

Restore settings

+ HUMIDIFIER INFO

+ TEST RUN

- TEST OUTPUTS

Fill valve

Drain valve

Fan control

Dry contact relay

Spare analog output

Ignition module 1

Ignition module 2

Ignition module 3

Ignition module 4

Blower speed control

Power vent control

MESSAGES

Message Details	Status	Action
Drain pending 2008-01-16 11:47:58 Auto drain/flush will occur at next scheduled time.	Active	<input type="button" value="CLEAR"/>
Duct HL trip 2008-01-16 11:47:59 Duct relative humidity has risen above set point, or high limit switch has opened.	Auto Cleared	

View messages by clicking on "View Messages" on any screen or by opening the Diagnostics screen.

Click on buttons to activate functions.

Clear messages by clicking here.

Diagnostics screen

Table 36-1:
Diagnostics menu

Menu item	Minimum value	Maximum value	Notes
Note: Your system might not have all of the items listed in this table (Pages 36 through 38).			
Download data			
Download to USB	-	-	Download all data sets to the USB flash drive.
Download via Ethernet	-	-	Only available from web page
Data point interval	30 seconds	900 seconds	Interval that data will be stored
USB backup/restore			
Back up settings	No	Yes	Humidifier settings can be backed up to or restored from a USB flash drive.
Restore settings	No	Yes	
Humidifier info			
Factory string	-	-	Displays as-shipped configuration string
Current string	-	-	Displays current configuration string
Serial number	-	-	Displays humidifier serial number
Firmware version	-	-	Displays current firmware version of Vapor-logic control board
Firmware date	-	-	Displays current firmware date of Vapor-logic control board
Model	-	-	
Voltage	-	-	AS150 systems only
Phase	-	-	AS150 systems only
Test outputs			
Fill valve	-	-	Cycles output to verify operation.
Pulse fill valve	-	-	<p>Universal water systems</p> <p>Note: Humidifiers with the universal water system use the same conductivity probes found in the three-probe system. Additional valves and software algorithms measure and control the water level for optimum operating efficiency. All water types and conductivities work with the universal water system. Vapor-logic automatically provides steady steam output while maintaining the water level between the bottom and middle probes. The humidifier will periodically perform probe checks to insure that the probes are being read accurately and to determine the quality of the incoming water. If the signal from the probe assembly begins to deteriorate, the "Clean probes" message appears in the Messages Log. Once the probe system reaches its maximum usable life, the humidifier shuts down and the "Faulty water probe" alarm appears.</p>
Drain valve	-	-	Cycles output to verify operation.
Fan control	-	-	
Dry contact relay 1 or 2	-	-	
Inlet valve	-	-	
Relief valve	-	-	
RO pump	-	-	

Continued

Diagnostics screen

Table 45-1: Diagnostics menu (continued)					
Menu item	Default value	Minimum value	Maximum value	Units	Description
Test outputs (continued)					
Contactors 1, 2, 3, or 4	-	-	-	-	Cycles output to verify operation.
SSR control	-	-	-	-	
Ignition module 1, 2, 3, or 4	-	-	-	-	
Blower speed control	-	-	-	-	
Power vent control	-	-	-	-	
Steam valve	-	-	-	-	
Test run*					
Test run percent	0	0	100	%	Set demand percent value between 0 and 100 to test.
Test run time	0	0	30	minutes	Set test run time duration between 0 and 30 minutes.
Start					
Stop					
* Humidifier test run will not occur if safety circuits (for example, duct high limit switch, airflow proving switch, or safety interlock switch) are not operating correctly.					

Table 46-1: Diagnostics menu		
Message	Description	Does message auto-clear?
Messages		
Replace contactors	Contactors have reached normal life span. Replace contactors.	No
Service unit	Regularly scheduled unit servicing is due.	No
Drain pending	Auto drain/flush will occur at next scheduled time.	Yes
No airflow	No duct airflow.	Yes
l-lock open	Interlock safety switch is open.	Yes
Freeze drain	Tank has drained to prevent freezing.	Yes
EOS active	The humidifier is draining or has drained and remains inactive until receiving another call for humidity.	Yes
Temp comp on	Humidifier output has been reduced because temperature compensation sensor reads a temperature on the inside-pane of an outside-wall window that could cause condensation.	Yes

Diagnostics screen

Table 46-1:
Diagnostics menu (continued)

Message	Description	Does message auto-clear?
Messages		
Clean probes	Water level control probes need cleaning. Check tank for cleaning.	No
Duct HL trip	Duct relative humidity has risen above the high limit set point, or high limit switch has opened.	Yes
Duct HL span	Duct high limit transmitter has entered the throttle span range and is approaching duct high limit set point.	Yes
Insufficient water	The low water probe is not in contact with water when there is a demand for humidity.	Yes
Boiling temp calibrated	Indicates actual humidifier boiling temperature at time of reading. This reading is taken after power-up by the tank sensor at the time of first steam creation.	Yes
Check cylinder / high water	Clean water, or end of cylinder life. After 10 hours of normalized 100% run time, target current has not been reached, water is at the high water probe, and current has not increased from the previous reading. Humidifier continues to operate.	Yes, if target current is reached
	Clean supply water (cleaner than cylinder water). Filling has stopped due to reaching the high water probe, and the current has decreased three times in a row. Humidifier continues to operate.	
Main enable open	Indicates demand signal is being ignored due to main enable input being open.	Yes
Excessive TDS	TDS measurement during RO production exceeds the TDS set point. The system will continue to operate but the membranes may need to be replaced. (Not available in Europe)	Yes
RO flush active	The unit is performing an RO flush or has done so and remains inactive until receiving another call.	Yes
Insufficient RO water flow	The RO supply water cannot meet demand.	No
Replace ignitors soon	Replace ignitors soon. Ignitors have been cycled to 80% of their expected life or there are other indications the ignitors may be worn out.	No
Low inlet water temp	The inlet water temperature is below 56°F (13° C).	Yes
Stage 1 efficiency below 50%	Stage 1 media is becoming clogged. Clean media or replace.	Yes
Stage 2 efficiency below 50%	Stage 2 media is becoming clogged. Clean media or replace.	Yes
Stage 3 efficiency below 50%	Stage 3 media is becoming clogged. Clean media or replace.	Yes
High flue temp, output reduced	Flue temperature is close to exceeding rated value. The output will temporarily be reduced by 50% to allow the flue to cool.	Yes
Hot drain water	The drain temperature has exceeded 145°F (63° C) for one minute. The drain tempering device may not be working properly.	Yes

Notes:

- The Messages Log displays message name, date and time of occurrence, plus "Active," "Cleared" or "Auto-cleared."
- Active messages display first in the Messages Log, followed by cleared messages (auto-cleared and/or manually-cleared) listed in order of occurrence.
- The Messages Log displays a maximum of 10 messages. Cleared messages leave the log first.
- If a message event occurs and is not manually or auto cleared during unit operation, the message will stay there until there is demand and the unit is running.

Alarms screen

FIGURE 39-1: KEYPAD/DISPLAY SCREENS

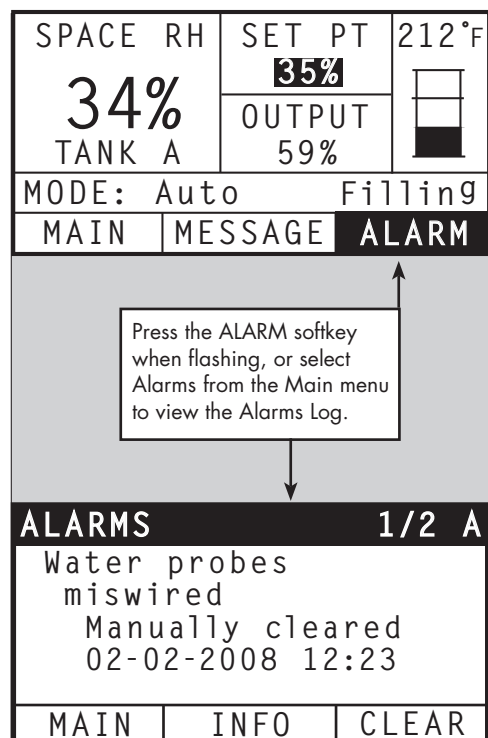

The Alarms menu displays system alarms. Using the keypad/display, go to the Alarms menu by pressing the Alarms softkey (which will be flashing if there is an Alarm), or by pressing the Home softkey and then the Alarms softkey. Using the Web interface, click on the View Alarms link in the upper left corner of any screen.

System alarms are listed in the Alarms Log. The Alarms Log displays the alarm name, date and time of occurrence, plus whether the alarm is active, has been cleared by an operator, or auto-cleared by Vapor-logic. The Alarms Log lists active alarms at the top of the list, followed by cleared alarms. The Alarms Log holds 30 alarms. As alarms are cleared, they move down the list below active alarms. When the Alarms list reaches 30 alarms, new alarms add to the top of the list and the oldest, cleared alarms leave the list. Alarm information is retained in nonvolatile memory if the Vapor-logic board loses power.

See Table 40-1 for alarms and their descriptions.

Alarm causes and recommended actions are listed in the troubleshooting section in this manual.

FIGURE 39-2: VAPOR-LOGIC WEB INTERFACE ALARMS SCREEN

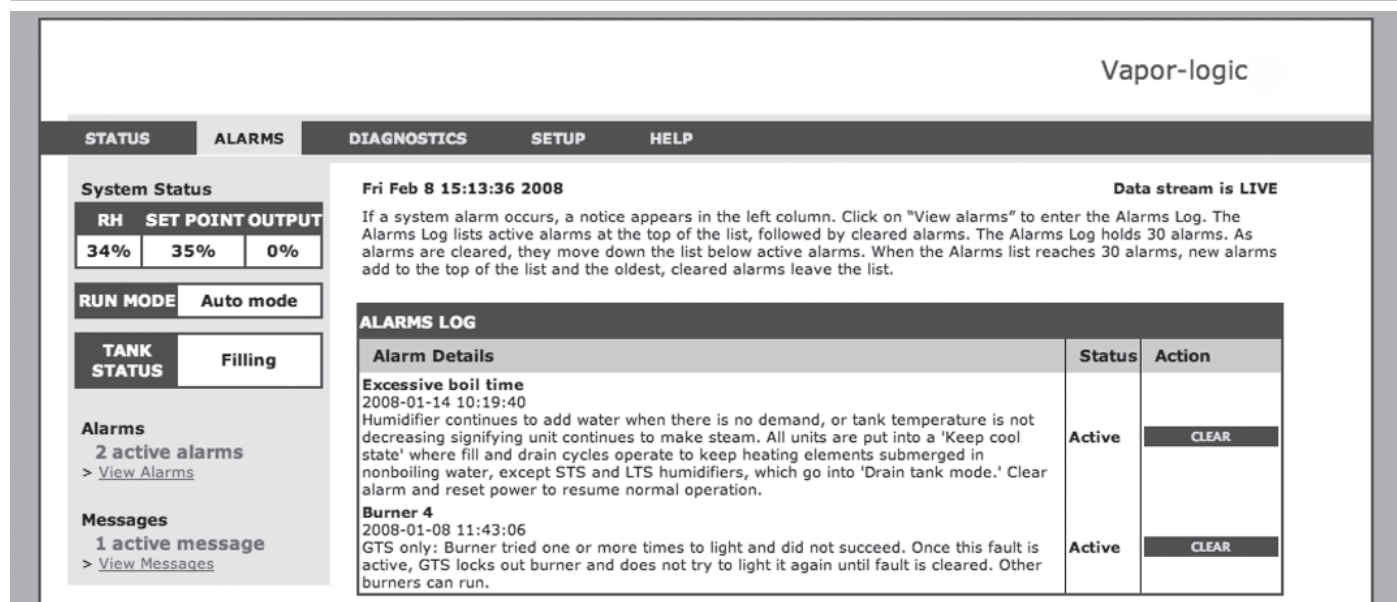

Alarms screen

Table 40-1:
Alarms menu

Alarm label	Description	Does alarm auto-clear?
Tank temp sensor failed	Tank temp sensor has failed.	No
Overtemp cutout	Tank temperature is greater than 230 °F (110 °C). Check for faulty tank temperature sensor, and ensure that water level is not too low. Check for and correct any other possible safety issues. Push manual reset on overtemp cutout switch, and cycle controller power to clear alarm.	No
RH signal out of range	RH signal is out of range.	Yes
Dew point signal out of range	Dew point signal is out of range.	Yes
Demand signal out of range	Demand signal is out of range.	Yes
Duct RH signal out of range	Duct RH signal is out of range. Sensor may be faulty.	Yes
Aux temp sense out of range	Auxiliary temp sensor signal is out of range.	Yes
Water probe miswired	Water probe head is miswired or faulty.	Yes
Faulty water probe	Water probe readings are suspect, likely caused by scale on probe.	No
Excess fill time	Fill valve has been on too long during initial tank fill. Bottom probe is not in contact with water.	Yes
Excess refill time	Re-filling is taking too long. Top probe is not in contact with water.	Yes
Tank not draining	Drain valve has been open for the prescribed amount of time based on the humidifier model, and water is still touching the low water probe.	Yes
Tank overtemp	Fault occurs at boiling temperature plus 25 °F (13 °C). All units are put into a keep-cool state where fill and drain cycles operate to keep tank cool. First resolve any safety issues, then resolve whatever is causing the problem. Restart the controller to clear the alarm.	No
Excessive boil time	Humidifier continues to add water when there is no demand, signifying humidifier is continuing to make steam. Humidifier is put into a keep-cool state where fill and drain cycles operate to keep tank water from boiling. First resolve any safety issues, then resolve whatever is causing the problem. Restart the controller, and clear the alarm. Note: This alarm applies only to non-DI/RO-water humidifiers and DI/RO-water humidifiers with EOS drain.	No
No SDU airflow	Airflow proving switch in the SDU (space distribution unit, a fan-based dispersion assembly) indicates no airflow. No steam is produced while alarm is active.	Yes
Overtemp cutout	Overtemp cutout circuit has opened. First resolve any safety issues, then resolve whatever is causing the problem. Restart the controller to clear the alarm.	No

Continued

Alarms screen

Alarm label	Description	Does alarm auto-clear?
Flue or tank over-temp cutout	The listed flue temperature switch or tank temperature switch has opened. These switches will close after the system has cooled.	Yes
Flue sensor out of range	Flue temperature sensor signal is out of range.	Yes
Drain sensor out of range	Drain temperature sensor signal is out of range.	Yes
Supply water failure	No water. Supply water failure, or drain malfunctioning/leaking. Fill has been on for 30 minutes without reaching high water probe or target current. Cycles the fill and drain valves 20 times and retries filling for 10 additional minutes before an alarm is generated. If not corrected, humidifier shuts down.	No
Supply water failure 2	No water in right cylinder. See above.	No
Excessive foaming	Continuous foaming causing a problem. Target current has been reached but is now below the -10% of nominal current, and high water probe has been wet for an extended period of time. – or – Fill was halted because top probe became wet, and current is reduced to 50% of when fill was halted. Humidifier will do a normal drain event. Alarm is generated if this condition occurs 10 times, indicating that foaming is a persistent problem. If not corrected, humidifier shuts down. Cylinder may need to be completely drained twice to prevent foaming. See "Start-up procedure" in <i>AS150 Electrode Steam Humidifier Installation, Operation, and Maintenance Manual</i> shipped with the humidifier.	No
Excessive foaming 2	Continuous foaming causing a problem in right cylinder. See <i>Excessive foaming</i> .	No
Overcurrent	Overcurrent; 120% over nominal. Conductivity build-up; drain malfunctioning/plugged; or too much condensate return. Drains up to 12 times to attempt to reduce current: <ul style="list-style-type: none"> • For drains 1 through 6, length of drain is incrementally increased. • For drains 4 through 12, drain valve is cycled ten times to loosen possible debris in drain. • For drains 7 through 12, drain duration is identical to drains 1 through 6, but tempering is pulsed at 5-second intervals. If not corrected, humidifier shuts down. 	No
Overcurrent 2	Overcurrent; 120% over nominal in right cylinder. See above.	No
Current sensor out of range	AS150 current sensor is out of range.	Yes
Current sensor 2 out of range	AS150 current sensor 2 is out of range.	Yes

PID tuning

When your system has a humidity or dew point transmitter, you can adjust and control the set point through the keypad/display or Web interface using a proportional, integral, and derivative (PID) control loop.

IMPROVES HUMIDIFIER RESPONSE TIME

With a PID loop, you can tune your system for maximum performance using the proportional (Kp), integral (Ki), and derivative (Kd) gain terms.

Kp = Proportional gain factor

Ki = Integral gain factor

Kd = Derivative gain factor

These gain factors work in the following way: The overall demand in a PID system is made up of three distinct parts—the proportional, the integral, and the derivative. Each of these parts is calculated and then multiplied by its corresponding gain factor. These gain factors are the setup variables you have access to from the Setup menu. By making a gain factor larger, you increase its overall influence on system demand. Once each PID component is multiplied by its gain factor, all three terms are added together to determine the overall demand percentage.

THE PROPORTIONAL TERM

The proportional term is the difference between the RH set point and the actual humidity multiplied by the proportional gain. For example, with a Kp of 80 and the actual humidity 5% below the RH set point, the proportional contribution to the demand is:

$5 \times 80 \times 0.085 = 33\%$ (the 0.085 is an internal scalar used to increase the usable span of Kp).

There is a problem with using only proportional gain to control the RH. In almost all applications there is some constant load on the humidifier just as there is a constant load on heating equipment. If the proportional term is all that is used, the actual humidity must be less than the set point for the humidifier to be on.

What happens is the humidifier finds a happy medium where the actual humidity is something less than the set point, which allows the humidifier to continue to run. This difference between the set point and the actual running humidity level is called the droop. This droop can be corrected using the next term, the integral.

Setup menu

The Setup menu is where system parameters can be changed. This menu is used primarily during initial installation, but can also be used for making changes or adjustments as needed during operation. Note that while all parameters can be changed, many changes also require a corresponding hardware change. Vapor-logic firmware will warn you of this during the setup process.

See Setup, beginning on Page 21, for more information about the Setup menu.

PID tuning

THE INTEGRAL TERM

The integral term is an accumulation of RH error over time multiplied by the integral gain. Every 1/10 second when the demand is updated, the instantaneous RH error (RH set point – actual RH) is added to a temporary variable that accumulates the error. This accumulated error is multiplied by the integral gain to create the integral term. The integral gain affects how fast the humidifier corrects a droop condition. The higher the integral gain (K_i), the faster the reaction. (An integral gain of zero disables this variable and allows the unit to run on the proportional term only.)

With an integral gain term greater than zero and an actual humidity below set point, the demand increases slightly with each update. If the actual humidity is above set point, the demand decreases slightly. The amount it increases or decreases depends on the magnitude of the RH error and the integral gain value. The closer you are to the set point, the smaller the addition or subtraction.

When looking at this control scheme, an interesting pattern occurs. The total demand signal for the humidifier is the sum of the proportional part, the integral part, and the derivative part. As the actual humidity approaches the set point, the integral portion makes up the majority of the demand, and the proportional part makes up very little. Once the set point is reached and the unit stabilizes, the entire demand is made up of the integral part because the proportional part is zero.

If the actual humidity goes over the set point, the integral term starts to decrease. In addition, the proportional term becomes negative and actually starts to subtract from the total system demand. These two terms work in conjunction with each other to bring the humidifier back to set point.

PID tuning

THE DERIVATIVE TERM

The derivative term is the measured change in error over time multiplied by the derivative gain (differentiating error with respect to time).

If the actual measured RH is below set point and is rising, the derivative term subtracts from the demand in anticipation of the approaching set point.

If the actual measured RH is below set point and is falling, the derivative term adds to the demand in anticipation of the need to get the demand up faster and start climbing toward set point.

If the actual measured RH is above set point and falling, the derivative term adds to the overall demand in anticipation of the approaching set point. It generally is used to increase damping and, in some cases, improves the stability of the system.

However, in the majority of control situations, the derivative term is not needed and is simply set to zero. The proportional term and integral term provide tight, accurate control without the addition of the derivative term.

PID BAND

The last user-controlled term in the PID equation is the PID band. The PID band defines the range of measured RH values (°F/°C for dew point control) where the PID loop is in operation. The PID loop is in operation when the measured RH is in the range of (RH set point – PID band) to (RH set point + PID band). If the measured RH is below the PID band, the PID calculations are suspended and the demand is set to 100%. Conversely, if the measured RH is above the PID band, the demand is set to 0%.

For example, if starting with an RH set point of 35% and a PID band of 10%, the PID loop operates when the actual humidity is in the range of 25% to 45%. If the actual humidity is lower than 25%, the humidifier is full on. If the actual humidity is above 45%, the humidifier demand is 0%. The PID band aids in speeding the response time of the system. It allows the RH to get somewhat close to the set point and then lets the PID loop precisely control the RH when it is within the PID band. The default value for the PID band is 10%.

Large spaces where the humidification system influences the RH very slowly typically benefit from a smaller PID band. Small spaces where the humidification system can quickly influence the RH typically benefit from a larger PID band. Rarely should it be set to less than 10%.

PID tuning

PID SETUP TIPS

A large PID band (10% to 20%) yields tighter and more stable control with longer response times. A small PID band produces quicker response times, but control may become unstable if the RH regularly goes outside the band.

As a rule, start with a PID band of 10%. When the humidifier is operating at steady state, make sure the RH does not go outside the PID band. The intent of the PID band is to quickly get the RH into a controllable range. To increase or decrease the effect of the proportional term on system performance, adjust the proportional gain (K_p).

However, for the majority of systems, the factory default setting of 80 is sufficient. Generally speaking, a large integral gain (K_i) quickens the system response but may cause it to oscillate and become unstable. A small integral gain yields tighter, more stable control at the expense of a long response time.

These principles can be applied in the following examples: If a system eventually reaches the desired RH level but takes a long time to do so without overshooting the set point, faster response can be achieved by increasing the integral gain. If the measured RH oscillates above and below the set point numerous times before finally reaching set point, decrease the integral gain.

Typically, if a large adjustment is made to the integral gain, better response is achieved by decreasing the magnitude of the change. Then, modify the proportional gain slightly in the same direction the integral gain was changed. RH history data, available for download from the Diagnostics menu, can aid when doing PID loop tuning.

Water level control

ELECTRODE STEAM HUMIDIFIERS

In electrode steam humidifiers (see Figure 46-1), steam output is directly related to the resistance of the water in the steam cylinder and, therefore, the conductivity of the water between the electrodes.

Recommended supply water conductivity for AS150 humidifiers is 125 to 1250 $\mu\text{S}/\text{cm}$.

Higher water levels cover more electrode surface and result in more steam; lower water levels cover less electrode surface and result in less steam. Since water conductivity and water level both correlate to steam output, Anden electrode humidifiers employ an algorithm that monitors conductivity and manages drain and fill events to optimize humidifier performance and provide proper steam output.

As the water in the cylinder boils into steam, the concentration of conductive ions increases until it reaches a threshold that triggers a drain and fill event. This rids the cylinder of highly conductive water and replaces it with less conductive fill water. The more conductive the fill water and the higher the demand, the more quickly the threshold is reached, and the more frequently the cylinder automatically drains and fills to stay within the parameters for proper steam output.

To prevent overflowing of the cylinder, filling stops if the water level reaches the high water sensor.

Supply water

Electrode steam humidifiers use tap or softened supply water. Demineralized, deionized, and reverse-osmosis water are not conductive enough for electrode steam humidifiers.

FIGURE 46-1:
WATER LEVEL CONTROL FOR ELECTRODE STEAM HUMIDIFIER

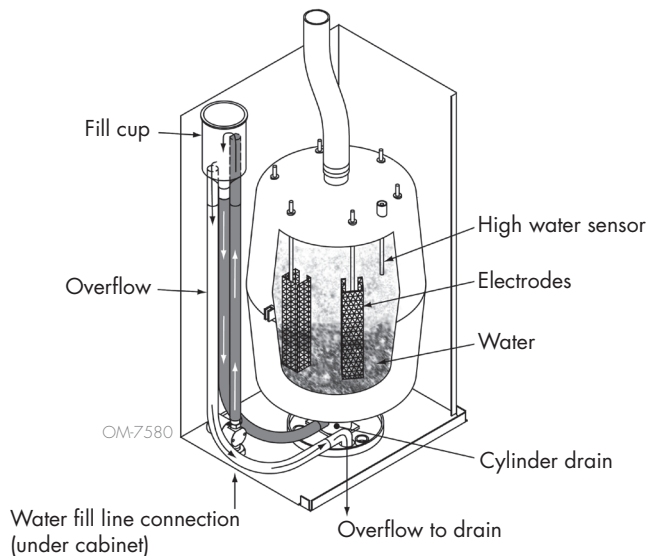

Options and features

FREEZE PROTECTION

Freeze protection is similar to aquastat operation with some exceptions. The freeze protect set point is fixed at 40 °F (4 °C). Its purpose is to prevent the tank from freezing in cold environments. Unlike aquastat, if a condition exists that prevents the heaters, burners, and valves from firing (such as an alarm, an external interlock switch is open, or the humidifier is in Standby mode), instead of remaining idle, the controller switches to manual drain run mode and the tank drains to prevent freezing. Change mode to Auto to resume operation.

When the tank is heating to prevent freezing, the word “Heating” appears on the Home screen. When the tank is draining or has drained to prevent freezing, the “Freeze drain” message appears in the Messages Log and the Message softkey label becomes highlighted.

FAN-BASED DISPERSION OPERATION

If your humidifier is equipped with a Space Distribution Unit (SDU), it is enabled after the Vapor-logic controller receives a call for humidity and the tank water is approaching boiling temperature.

When the humidifier no longer receives a call for humidity, it stops heating and the SDU or Area-type fan continues to run for the time delay period (as defined in the fan-based dispersion section Setup menu).

SENSOR OFFSETS

All external transmitters shipped with Vapor-logic can be field calibrated from the Setup menu. For example, if the system is equipped with an RH transmitter, there is an RH offset setting.

The factory default for all transmitter offset settings is zero. The sensors that have this adjustment capability are the humidity, duct high limit, temperature compensation, and dew point transmitters.

Options and features

AUTOMATIC DRAIN SEQUENCE, TAP/SOFTENED WATER

When configured to run a tap/softened water humidifier with an automatic drain valve, Vapor-logic uses an automatic drain sequence (ADS) to reduce mineral accumulation in the tank and drain line, which decreases tank maintenance.

The automatic drain sequence starts by opening the drain valve to empty the tank. When the drain duration ends, the fill and drain valves remain open to flush the tank. When the flush duration ends, the automatic drain sequence is complete and the humidifier resumes normal operation. The default drain and flush durations are model-specific and can be adjusted in the water management section of the Setup menu.

Automatic draining and flushing parameters are defined in the water management section of the Setup menu:

- First, automatic draining and flushing must be enabled.
- Second, the amount of water converted to steam before an automatic drain sequence begins must be defined (Usage). Defaults for this value are model-specific and are calculated based on operating 200 hours at 100% capacity. Go to the Setup menu to view or change this setting for your humidifier.
- Third, days of the week when the automatic drain sequence can occur must be defined. This means that once the Usage requirement is met, the automatic drain sequence can occur on the first allowed day (allowed days default is all days).
- Last, time of day when the automatic drain sequence occurs must be defined (default value is midnight).

For example, if you use factory default settings for the automatic drain sequence, the first automatic drain sequence will occur at midnight on any day of the week once the model-specific usage requirement has been met. If you want to change these settings, go to the water management section of the Setup menu.

Note that the automatic drain sequence is designed for a tap/softened water humidifier with electric drain and fill valves.

Drain algorithm for AS150 humidifiers

AS150 humidifiers employ a drain algorithm that is written specifically for how electrode steam humidifiers function. See "Electrode steam humidifiers" on Page 46.

Options and features

DRAINING WHEN USING SOFTENED WATER

When using softened water, draining occurs for a one-minute duration after a period of time based on 1000 hours of 100% operation to remove residue from the drain valve mechanism. End-of-season draining occurs as described below.

END-OF-SEASON DRAIN

If there is no call for humidity for a user-defined time period, the humidifier performs an end-of-season (EOS) drain where the drain valve remains open for ten hours to allow the tank to drain and then closes. If the humidifier receives a call for humidity after the ten-hour end-of-season drain-down period has begun, the controller stops the end-of-season draining, the tank refills, and the humidifier resumes normal operation. The user-defined inactivity time period (idle time) is defined in the end-of-season drain section of the Setup menu. This option is available only on units equipped with electric drain and fill valves.

SERVICE INTERVAL

The Vapor-logic controller tracks the amount of water converted to steam by the humidifier and the number of hours the humidifier runs. When the amount of steam or hours of run time exceeds the user-defined service interval (pounds, kilograms, or hours, adjusted in the Setup menu), "Service unit" appears in the Messages Log.

The humidifier continues to operate after the message appears. The message notifies the user that the service interval was reached and the humidifier should be cleaned. The message remains in the Messages Log until it is cleared or until the Messages Log adds 10 new messages (the maximum number of messages the log holds).

Options and features

SETTING DATE AND TIME

The Vapor-logic controller contains a real-time clock that is used for several features including the drain and flush sequence and alarm logging. If you need to reset the date or time, go to the Setup menu.

Note: Verify the date and time settings after every firmware upgrade.

BATTERY BACKUP, NONVOLATILE MEMORY

If there is a power outage, date and time settings will be saved. Alarms, unit configuration, and usage timers will remain in nonvolatile memory indefinitely.

SECURITY/PASSWORD

To control who can change Vapor-logic settings, enable the security function and define a password in the Setup menu. Enter four digits, numbers only, and define the time-out period (minutes of inactivity before Vapor-logic reverts to read-only mode). The Web interface and the keypad/display can have separate passwords.

Important: Write down the password and keep in a secure location.

Options and features

DOWNLOADING HISTORICAL DATA

Vapor-logic acquires data at one-minute intervals and retains it for seven rolling days. These data, available for download and sorting, contain the details shown in Table 51-1.

Note: Data is saved to nonvolatile memory every 60 minutes. If unit power is lost, up to 60 minutes of data could be lost.

Go to the **Download data** section of the Diagnostic screen for download options.

Table 51-1:

Sample of data log downloaded and sorted

Time	SpaceRH or Demand	Aux Temp (°F)	Tank Temp (°F)	BTU's used	Lbs steam	Output (%)	Alarm/Msg	Alarm/Msg Status	Current Config: xx##xx#x###xx	Factory Config: xx##xx#x###xx
1/26/10 9:36 AM	23	0	212	567019018	421066	23			—	—
1/26/10 9:37 AM	23	0	212	567021350	421068	23				
1/26/10 9:38 AM	23	0	211	567023681	421070	23				
1/26/10 9:39 AM							low_water_cutout	Auto cleared message		
1/26/10 9:40 AM	23	0	210	567028344	421073	23				
1/26/10 9:41 AM	23	0	211	567030677	421075	23				
1/26/10 9:42 AM	23	0	212	567033008	421077	23				
1/26/10 9:43 AM	23	0	212	567035339	421079	23				
1/26/10 9:44 AM							Unit Start	Auto cleared message		

To sort data (as shown above) with alarms and messages listed in the order they occurred:

1. Import the data into a spreadsheet program, such as Microsoft Excel.
2. Set the Time column to be displayed in the date-time format.
3. Sort all rows by "Time" in ascending order.

BACKING UP AND RESTORING DATA

Vapor-logic data can be backed up to and restored from a USB flash drive. The backup file contains all information relative to the humidifier, including firmware, user settings, model number, serial number, and the configuration string.

Backup files use the serial number in the backup file name so that the file is easily matched to a particular humidifier.

Firmware updates

To create a backup file:

1. Insert a USB flash drive into the USB port on the Vapor-logic board.
2. Go to Diagnostics/USB backup-restore/Back up settings
3. Select Yes. The display will prompt you when backup is complete.

To restore from a backup file:

1. Insert a USB flash drive with that humidifier's backup file into the USB port on the Vapor-logic board.
2. Go to Diagnostics/USB backup-restore/Restore settings.
3. Select Yes. Note that the serial number of the humidifier and backup file must match to complete the restore process.

DOWNLOADING FIRMWARE UPDATES

The Vapor-logic controller can be field upgraded to the latest firmware version via the USB port on the Vapor-logic board. Firmware updates are available at no charge on the Anden website.

To update your Vapor-logic controller to the latest firmware version, perform the following procedure:

1. Navigate to www.Anden.com.
2. Go to **Support & Literature** on the site navigation menu.
3. Select **Technical Support**.
4. Click on **firmware updates**.
5. Navigate to **Vapor-logic6** and click version download link.
6. Plug a reliable USB flash drive into a USB port on your computer, and prepare the flash drive as follows:
 - a) Move or delete all files from the drive.
 - b) Make sure it has at least 16 MB of free space.
 - c) Make sure it is not partitioned into multiple drives.
7. Perform the procedure in Table 53-1.

Firmware updates

Table 53-1:
Downloading Vapor-logic firmware updates

1. Click the link shown to the right on the **Vapor-logic firmware updates** page of www.Anden.com.

If a security window appears, click the **Save** button.

Note: The screenshots in this table depict typical Internet Explorer screens in Windows XP. While your browser and operating system might be set up differently, the screenshots are provided as a general road map.



2. When prompted for a save location, choose your desktop.
3. Click the **Save** button.

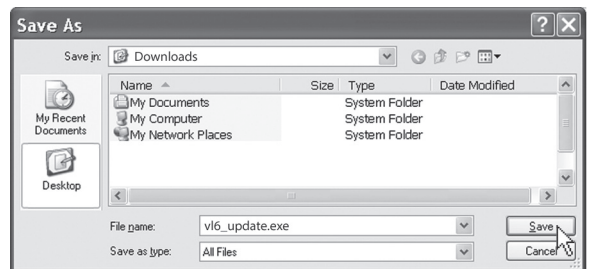

4. On your desktop, double-click the new **vl6_update.exe** file.



5. If a Security Warning appears, click the **Run** button.

A WinZip Self-Extractor window appears.

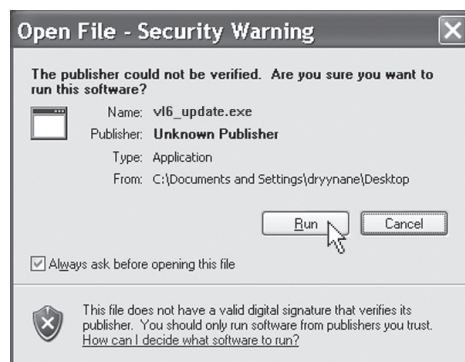

Continued

Firmware updates

Table 53-1:
Downloading Vapor-logic firmware updates (continued)

6. Click the **Browse** button in the WinZip Self-Extractor window, and select your USB flash drive as the target location.

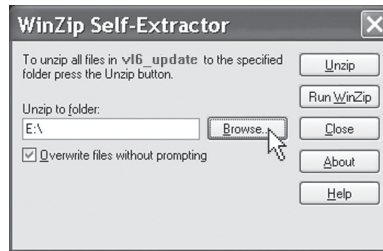

7. Click the **Unzip** button in the WinZip Self-Extractor window.

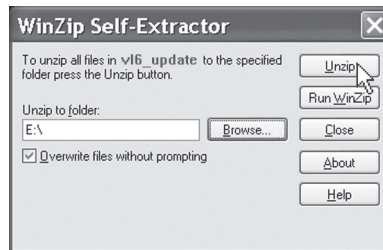

A WinZip window opens to confirm that the firmware update has been unzipped.

8. Click the **OK** button.



9. Click the **Close** button to close the WinZip Self-Extractor window.

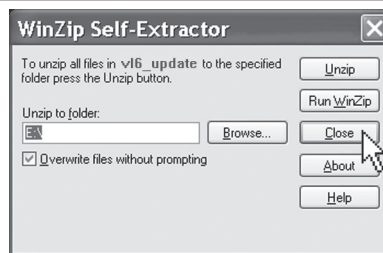

10. Open your USB flash drive. Confirm that it contains a folder named **v16_update_xx.xx.xx** (where x represents the version number) and that it has today's timestamp.

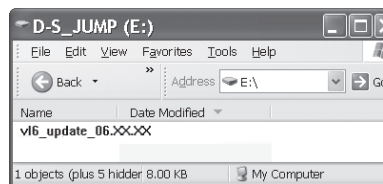

11. Remove the USB flash drive from your computer.

12. Proceed to "Installing firmware updates" on Page 55.

Firmware updates

INSTALLING FIRMWARE UPDATES

1. Place the humidifier system in Standby mode.
2. **IMPORTANT:** To prevent static damage to the USB flash drive and controller, ground yourself by briefly touching the humidifier's electrical subpanel before touching any part of the controller board or doing Step 3. See the Warning.
3. With the board powered, insert the USB flash drive loaded with the unzipped firmware update folder into the Vapor-logic board USB port.

CAUTION

Do not remove USB flash drive or cycle power early

During Steps 4 and 5, do not remove the USB flash drive or cycle the power until the signal occurs as explained in Step 5.

4. The update process begins immediately and takes up to 1 minute. Wait for the relay on the Vapor-logic board to begin clicking continuously. The water probe LEDs on the board will blink occasionally during the update process.
5. When the relay on the Vapor-logic board begins to click continuously, remove the USB flash drive from the Vapor-logic board USB port. When the USB flash drive is removed, the Vapor-logic controller and display reboot with the updated firmware.
6. Verify the update by checking the Vapor-logic firmware version as follows:
 - a) Select Diagnostics in the keypad/display Main menu.
 - b) Select Humidifier info.
 - c) Scroll down to Firmware version.

The firmware version displayed should match the version number of the **vl6_update xx.xx.xx** folder on the USB flash drive (where x represents the version number).

7. Verify humidifier operation, and return it to service.

Not all USB drives perform equally. If a USB flash drive fails to update the Vapor-logic firmware, perform the following procedure with a different USB flash drive:

WARNING

Electric shock hazard
All circuits must be energized for this firmware update procedure. Contact with energized circuits can cause severe personal injury or death as a result of electric shock.

To prevent shock when grounding to the electrical subpanel, touch the subpanel along its edge, away from wires and components.

Test outputs and test run

1. Prepare a new flash drive as described in Step 3 of “Downloading firmware updates” on Page 52.
2. Repeat Steps 4 through 11 in Table 53-1.
3. Repeat Steps 1 through 7 on Page 55.

TEST OUTPUTS

When completing an installation or repair, cycle all outputs, such as fill valve, drain valve, etc., to verify operation. Go to the test outputs section of the Diagnostics menu and scroll through each connected output to verify operation. During testing, the humidifier mode changes to Standby and the tank status changes to Test.

TEST RUN

Vapor-logic has a test run capability to confirm system functionality. This capability allows a technician to simulate a demand for steam production when there isn't one (such as when performing routine maintenance). To confirm functionality, go to the test run section of the Diagnostics menu. Set system demand percent and set test run time duration. During testing, the humidifier mode changes to Standby and the tank status changes to Test.

mc_102108_1350

Modbus and BACnet interoperability

Vapor-logic comes standard with Modbus, or with BACnet or LonTalk if ordered. Vapor-logic can connect to building automation systems using these protocols. Variables are defined in the tables on the following pages.

Note: For retrofit BACnet or LonTalk installations, contact your local Anden representative to purchase a BACnet or LonTalk upgrade.

CONNECTIONS

1. If connecting to a Modbus or BACnet MS/TP system, connect Modbus or BACnet system wiring to terminal P7 on the Vapor-logic board (positive to positive, negative to negative).
If connecting to a BACnet/IP system, connect BACnet system wiring to the Ethernet connection.
2. If connecting to a LonTalk system, connect the LON ProtoCessor module per Step 3 in Figure 57-1.
3. Disconnect power to the Vapor-logic board, wait 5 seconds, and reconnect power.
4. Set up communication with Vapor-logic using your Modbus, BACnet, or LonTalk network manager, referencing Table 58-1.

INSTALLING LONTALK AS A RETROFIT

1. Turn off power to the unit.
2. Touch the unit's bare metal frame before handling the LON ProtoCessor module, and hold onto frame while handling the module.
3. While handling the module, hold it by the edge. Avoid touching the components or circuit board.
4. Plug LON ProtoCessor module into mounting pins (as shown in Figure 57-1) with LonTalk connector at the edge of the board. Make sure all pins are seated in the connector.
5. Connect LonTalk system wires to LON ProtoCessor module as shown in Step 3 at right.
6. Turn on power to the unit.
7. Using either the keypad/display or Web interface go to the Communications section of the Setup menu to enable LonTalk communication.
8. Set up communication with Vapor-logic using your LonTalk network manager, referencing Table 58-1.

Modbus and BACnet interoperability

Table 58-1:
Interoperability variable and object names

Variable name and BACnet object name	Read Only (RO) or Read Write (RW)	Modbus register number*	BACnet Object Type and Instance	LonTalk variable names**	Description	Units		Range	
						I-P units	SI units	I-P units	SI units
Read-only analog variables									
Space_RH	RO	IR-1 30001	AI-01	nvoSpaceRH	Relative humidity content of the air in the space being humidified.	%	%	0 to 100	0 to 100
Space_dew_point	RO	IR-2 30002	AI-02	nvoSpaceDewPoint	Dew point of the air in the space being humidified.	°F	°C	20 to 80	-6 to 26
Duct_RH	RO	IR-3 30003	AI-03	nvoDuctRH	Relative humidity content of air in the duct.	%	%	0 to 100	0 to 100
Steam_demand_mass	RO	IR-4 30004	AI-04	nvoSteamDmndMass	Steam demand in pounds or kilograms per hour.	lbs/hr	kg/h	0 to 100,000	0 to 100,000
Steam_demand_percent	RO	IR-5 30005	AI-05	nvoSteamDemandP	Steam demand as a percentage of the humidifier's total capacity.	%	%	0 to 100	0 to 100
Aux_temp	RO	IR-6 30006	AI-06	nvoAuxTemp	Temperature of auxiliary temperature sensor.	°F	°C	-20 to 160	-29 to 170
Water_temp	RO	IR-7 30007	AI-07	nvoTankTemp	Temperature of the water in the humidifier's evaporating chamber.	°F	°C	-240 to 265	-151 to 129
Steam_output_mass	RO	IR-8 30008	AV-1	nvoSteamOutMass	Estimated amount of steam the humidifier is producing in pounds or kilograms per hour.	lbs/hr	kg/h	0 to 100,000	0 to 100,000
Steam_output_percent	RO	IR-9 30009	AV-2	nvoSteamOutputP	Estimated amount of steam the humidifier is producing as a percentage of the humidifier's total capacity.	%	&	0 to 100	0 to 100
Water_until_ADS	RO	IR-10 30010	AV-3	nvoWaterUntilADS	Pounds or kilograms of water remaining to be converted to steam before the next automatic drain sequence (ADS) cycle.	100 lbs	100 kg	0 to 2,200,000	0 to 1,000,000
Water_until_service	RO	IR-11 30011	AV-4	nvoWaterTilSrvc	Pounds or kilograms of water remaining to be converted to steam before next service cycle.	100 lbs	100 kg	0 to 2,200,000	0 to 1,000,000

* See Note 1 on Page 66.

** See Note 2 on Page 66.

Continued

Modbus and BACnet interoperability

Table 59-1:
Interoperability variable and object names (continued)

Variable name and BACnet object name	Read Only (RO) or Read Write (RW)	Modbus register number*	BACnet Object Type and Instance	LonTalk variable names**	Description	Units		Range	
						I-P units	SI units	I-P units	SI units
Read-only analog variables (continued)									
MT_sys_output_mass_hr	RO	IR-23 30023	AI-08	nvoMT_SteamOMass	MT steam demand mass	lbs/hr	kg/h	0 to 100000	0 to 100000
MT_sys_output_pctnt	RO	IR-25 30025	AI-09	nvoMT_SteamOP	MT steam demand percent	%	%	0 to 100	0 to 100
Current_1	RO	IR-26 30026	AI-10	nvoXT_current1	AS150 operating current	Amps	Amps	0 to 100	0 to 100
Current_2	RO	IR-27 30027	AI-11	nvoXT_current2	AS150 operating current, right cylinder	Amps	Amps	0 to 100	0 to 100
Current_COC	RO	IR-30 30030	AI-14	nvoCurrentCOC	Current tank COC	-	-	0 to 1000	0 to 1000
Supply_water_conductivity_μs	RO	IR-31 30031	AI-15	nvoSupply_μS	Supply water conductivity in μS	μS	μS	0 to 1000	0 to 1000
Stage_1_temperature	RO	IR-32 30032	AI-16	nvoStage1Temp	Stage 1 temperature	°F	°C	0 to 150	0 to 150
Stage_2_temperature	RO	IR-33 30033	AI-17	nvoStage2Temp	Stage 2 temperature	°F	°C	0 to 150	0 to 150
Stage_3_temperature	RO	IR-34 30034	AI-18	nvoStage3Temp	Stage 3 temperature	°F	°C	0 to 150	0 to 150
Supply_air_temperature	RO	IR-35 30035	AI-19	nvoSupplyAirTemp	Supply air temperature	°F	°C	0 to 150	0 to 150
Stage_1_effectiveness	RO	IR-36 30036	AI-20	nvoStage1Effect	Stage 1 media effectiveness	%	%	0 to 100	0 to 100
Stage_2_effectiveness	RO	IR-37 30037	AI-21	nvoStage2Effect	Stage 2 media effectiveness	%	%	0 to 100	0 to 100
Stage_3_effectiveness	RO	IR-38 30038	AI-22	nvoStage3Effect	Stage 3 media effectiveness	%	%	0 to 100	0 to 100
Output_temperature	RO	IR-39 30039	AI-23	nvoOutputTemp	Output temperature	°F	°C	0 to 150	0 to 150
Wet_bulb_temperature	RO	IR-40 30040	AI-24	nvoWetBulbTemp	Wetbulb temperature	°F	°C	0 to 150	0 to 150
Storage_pressure	RO	IR-41 30041	AI-25	nvoStoragePress	Storage pressure	psi	bar	0 to 100	0 to 100
Pump_hours	RO	IR-42 30042	AI-26	nvoPumpHours	Pump runtime hours	hours	hours	0 to 100000	0 to 100000
TDS	RO	IR-43 30043	AI-27	nvoTDS	TDS	-	-	0 to 1000	0 to 1000
HPS_pump_station_operating	RO	IR-44 30044	AI-28	nvoActPSnumber	Active pump station number	-	-	0 to 4	0 to 4

Continued

Modbus and BACnet interoperability

Table 60-1:
Interoperability variable and object names (continued)

Variable name and BACnet object name	Read Only (RO) or Read Write (RW)	Modbus register number*	BACnet Object Type and Instance	LonTalk variable names**	Description	Units		Range	
						I-P units	SI units	I-P units	SI units
Setup variables									
Run_mode	Write	HR-1 40001	MSV-01	nviRunMode	Mode of the unit or system. The defined options are: 1 Auto 2 Local standby 3 System standby 4 Manual drain	-	-	1 to 4	1 to 4
	Read	HR-1 40001	MSV-01	nvoRunMode	Mode of the unit or system. The defined options are: 1 Auto 2 Local standby 3 System standby 4 Manual drain 5 Test outputs 6 Test run	-	-	1 to 6	1 to 6
Space_RH_set_point	Write	HR-2 40002	AV-05	nviSpaceRHsetPt	Humidity set point for the space being humidified.	%	%	0 to 100	0 to 100
Space_dew_point_set_point	Write	HR-3 40003	AV-06	nviSpaceDewPtSP	Dew point set point for the space being humidified.	°F	°C	20 to 80	-6 to 26
Duct_high_limit_set_point	Write	HR-4 40004	AV-07	nviDuctHLsetPt	Duct high limit set point.	%	%	0 to 100	0 to 100
* See Note 1 on Page 66. ** See Note 2 on Page 66.									

Continued

Modbus and BACnet interoperability

Table 61-1:
Interoperability variable and object names (continued)

Variable name and BACnet object name	Read Only (RO) or Read Write (RW)	Modbus register number*	BACnet Object Type and Instance	LonTalk variable names**	Description	Units		Range	
						I-P units	SI units	I-P units	SI units
Setup variables (continued)									
Fieldbus_demand_mass	Write Only	HR-5 40005	AV-08	nviFbusDemndMass	Steam output (as demanded via fieldbus) in pounds or kilograms per hour. If the request exceeds the unit's capacity, the unit will run at 100% capacity.	lbs/hr	kg/h	0 to 100,000	0 to 100,000
Fieldbus_demand_%	Write Only	HR-6 40006	AV-09	nviFldBusDemandP	Steam output (as demanded via the fieldbus) as a percentage of the humidifier's total capacity.	%	%	0 to 100	0 to 100
PID_band	RW	HR-7 40007	AV-10	nciPIDband	PID band.	%	%	0 to 50	0 to 50
PID-Kp	RW	HR-8 40008	AV-11	nciPIDkp	PID-Kp (proportional gain) factor.	-	-	0 to 1000	0 to 1000
PID-Ki	RW	HR-9 40009	AV-12	nciPIDki	PID-Ki (integral gain) factor.	-	-	0 to 1000	0 to 1000
PID-Kd	RW	HR-10 40010	AV-13	nciPIDkd	PID-Kp (derivative gain) factor.	-	-	0 to 1000	0 to 1000
MT_runmode	Write	HR-14 40014	MSV-02	nviMTRunMode	"MT runmode; 1 = system standby, 2 = system auto"	-	-	1 to 2	1 to 2
	Read	HR-14 40014	MSV-02	nvoMTRunMode	"MT runmode; 1 = system standby, 2 = system auto"	-	-	1 to 2	1 to 2
MT_steam_req_mass_hr	Write Only	HR-15 40015	AV-14	nviMT_FBDmndMass	MT fieldbus request for steam in pounds or kilograms per hour	lbs/hr	kg/h	0 to 100000	0 to 100000
MT_steam_req_sys_pcmt	Write Only	HR-17 40017	AV-15	nviMT_FBDmndP	MT fieldbus request for steam in percentage of system capacity	%	%	0 to 100	0 to 100
Pump_1_hours	RW	HR-18 40018	AV-16	nviPump1Hours	HPS number of hours pump 1 has run since reset	hours	hours	0 to 100000	0 to 100000
Pump_2_hours	RW	HR-19 40019	AV-17	nviPump2Hours	HPS number of hours pump 2 has run since reset	hours	hours	0 to 100000	0 to 100000
Target_COC	RW	HR-20 40020	AV-18	nviTargetCOC	Desired cycles at concentration	-	-	0 to 1000	0 to 1000
Pump_selected	RW	HR-21 40021	AV-19	nvoPumpSelect	HPS systems only	0 = Pump 1; 1 = Pump 2			

* See Note 1 on Page 66.

** See Note 2 on Page 66.

Continued

Modbus and BACnet interoperability

Table 62-1:
Interoperability variable and object names (continued)

Variable name and BACnet object name	Read Only (RO) or Read Write (RW)	Modbus register number*	BACnet Object Type and Instance	LonTalk variable names**	Description	Units		Range	
						I-P units	SI units	I-P units	SI units
Read-only digital I/O									
Airflow_proving_switch	RO	DI-1 10001	BI-01	nvoAirflowSwitch	0=Open; 1=Closed				
Duct_HL_switch	RO	DI-2 10002	BI-02	nvoDuctHLswitch	0=Open; 1=Closed				
Safety_interlock	RO	DI-3 10003	BI-03	nvoSafetyI-lock	0=Open; 1=Closed				
Combustion_air_damper_(GTS)	RO	DI-4 10004	BI-04	nvoCombustAirDmp	0=Damper Closed; 1=Damper Open				
Stage_1_(High-Pressure System)	RO	DI-4 10004	BI-04	nvoCombustAirDmp	0=Closed; 1=Open				
Flue_pressure_switch_(GTS)	RO	DI-5 10005	BI-05	nvoFluePressurSw	0=Open; 1=Closed				
Stage_2_(High-Pressure System)	RO	DI-5 10005	BI-05	nvoFluePressurSw	0=Closed; 1=Open	-	-	-	-
Power_vent_switch_(GTS)	RO	DI-6 10006	BI-06	nvoPowerVentSwch	0=Vent Off; 1=Vent On				
XV_header_status_(STS)	RO	DI-6 10006	BI-06	nvoPowerVentSwch	0=Not ready; 1=Ready				
Stage_3_(High-Pressure System)	RO	DI-6 10006	BI-06	nvoPowerVentSwch	0=Closed; 1=Open				
Low_water_sensor_(GTS)	RO	DI-7 10007	BI-07	nvoLowWaterSensr	0=No Water; 1=Water				
Fill_valve	RO	DI-8 10008	BO-01	nvoFillValve	0=Closed; 1=Open				
Drain_valve	RO	DI-9 10009	BO-02	nvoDrainValve	0=Not Draining; 1=Draining				
MT_active_fault_exists_somewhere	RO	DI-10 10010	BI-08	nvoMt_AlarmSomWr	0=No; 1=Yes	Multi-tank only			
MT_active_message_exists_somewhere	RO	DI-11 10011	BI-09	nvoMt_MsgSomWr	0=No; 1=Yes	Multi-tank only			
High_water_sensor	RO	DI-12 10012	BI-10	nvoXT_HighWater1	0=No Water; 1=Water	AS150 systems only			
High_water_sensor_2	RO	DI-13 10013	BI-11	nvoXT_HighWater2	0=No Water; 1=Water	Right cylinder, 2-cylinder AS150 systems only			
VFD_drive_fault	RO	DI-14 10014	BI-12	nvoDriveFault	0 = No Fault; 1 = Fault	HPS systems only			
XV: 2 position shutoff valve	RO	DI-15 10015	BO-03	N/A	0 = Valve not powered; 1 = Valve powered				
XV: 2 position shutoff valve end switch	RO	DI-16 10016	BI-13	N/A	0 = Open; 1 = Closed	XV with VL only			
XV: Float switch	RO	DI-17 10017	BI-14	N/A	0 = Empty, OK to run; 1 = Full	XV with VL only			

* See Note 1 on Page 66.

** See Note 2 on Page 66.

Continued

Modbus and BACnet interoperability

Table 63-1:
Interoperability variable and object names (continued)

Variable name and BACnet object name	Read Only (RO) or Read Write (RW)	Modbus register number*	BACnet Object Type and Instance	LonTalk variable names**	Description	Units		Range	
						I-P units	SI units	I-P units	SI units
Faults and alarms									
ProgOutput1_status	RO	DV-1 1	BV-01	nvoDryContact1	0=Open; 1=Closed				
ProgOutput2_status	RO	DV-2 2	BV-02	nvoDryContact2					
Active manual clear alarms exit	RO	DV-3 3	BV-03	nvoAlarms	Flag that a manual clear alarm exists in the system				
Clear all active alarms	RW	DV-4 4	BV-04	nviClearAllFault	When set will clear all active faults				
Tank temp sensor failed	RW	DV-5 5	BV-05	nvoAlrmTnkTmpSen	See Table 49-1, Alarms menu				
Tank overtemp, Unit reboot required	RW	DV-6 6	BV-06	nvoAlrmOvertemp					
Signal at RH input out of range	RW	DV-7 7	BV-07	nvoAlrmRHsignal nvoAlrmDewPtSgnl nvoAlrmDemndSgnl					
Duct RH sig out of range	RW	DV-8 8	BV-08	nvoAlrmDuctRHsig					
Aux temp sense out of range	RW	DV-9 9	BV-09	nvoAlrmAuxTemp					
Water probe miswired	RW	DV-10 10	BV-10	nvoAlrmProbeWire		-	-	-	-
Faulty water probe HPS: VFD fault	RW	DV-11 11	BV-11	nvoAlrmProbeFail					
Excessive fill time	RW	DV-12 12	BV-12	nvoAlrmFillTime					
Excessive refill time	RW	DV-13 13	BV-13	nvoAlrmRefilTime					
Tank not draining LMH: Check humidifier floats	RW	DV-14 14	BV-14	nvoAlrmNoDrain					
Excessive boil time, Unit reboot required	RW	DV-15 15	BV-15	nvoAlrmXessWater					
No SDU airflow	RW	DV-16 16	BV-16	nvoAlrmNoSDUair					
GTS: No power vent airflow STS: XV header flooded	RW	DV-17 17	BV-17	nvoAlrmPrVentAir					
No combustion airflow	RW	DV-18 18	BV-18	nvoAlrmNoCombAir					
Blocked flue	RW	DV-19 19	BV-19	nvoAlrmBlockdFlu					
Burner 1 fault	RW	DV-20 20	BV-20	nvoAlrmBurner1					

* See Note 1 on Page 66.

** See Note 2 on Page 66.

Continued

Modbus and BACnet interoperability

Table 64-1:
Interoperability variable and object names (continued)

Variable name and BACnet object name	Read Only (RO) or Read Write (RW)	Modbus register number*	BACnet Object Type and Instance	LonTalk variable names**	Description	Units		Range	
						I-P units	SI units	I-P units	SI units
Faults and alarms (continued)									
Burner 2 fault	RW	DV-21 21	BV-21	nvoAlrmBurner2	See Table 49-1, Alarms menu	-	-	-	-
Burner 3 fault	RW	DV-22 22	BV-22	nvoAlrmBurner3					
Burner 4 fault	RW	DV-23 23	BV-23	nvoAlrmBurner4					
Ignition module 1 fault	RW	DV-24 24	BV-24	nvoAlrmIgnitMod1					
Ignition module 2 fault	RW	DV-25 25	BV-25	nvoAlrmIgnitMod2					
Ignition module 3 fault	RW	DV-26 26	BV-26	nvoAlrmIgnitMod3					
Ignition module 4 fault	RW	DV-27 27	BV-27	nvoAlrmIgnitMod4					
GTS: Blower 1 fault WM: Temp sensor stage 1 fault	RW	DV-28 28	BV-28	nvoAlrmBlower1					
GTS: Blower 2 fault WM: Temp sensor stage 2 fault	RW	DV-29 29	BV-29	nvoAlrmBlower2					
GTS: Blower 3 fault WM: Temp sensor stage 3 fault	RW	DV-30 30	BV-30	nvoAlrmBlower3					
GTS: Blower 4 fault WM: Temp sensor In fault	RW	DV-31 31	BV-31	nvoAlrmBlower4					
Gas valve 1 fault	RW	DV-32 32	BV-32	nvoAlrmGasValve1					
Gas valve 2 fault	RW	DV-33 33	BV-33	nvoAlrmGasValve2					
Gas valve 3 fault	RW	DV-34 34	BV-34	nvoAlrmGasValve3					
Gas valve 4 fault	RW	DV-35 35	BV-35	nvoAlrmGasValve4					
GTS: Low water Electric: Overtemp cutout, Unit reboot required	RW	DV-36 36	BV-36	nvoAlrmLowWater					
Excessive foaming 2	RW	DV-37 37	BV-37	nvoAlrmFoaming2					
Current sensor out of range	RW	DV-51 51	BV-51	nvoAlrmCurSense1					
Current sensor 2 out of range	RW	DV-52 52	BV-52	nvoAlrmCurSense2					
* See Note 1 on Page 66. ** See Note 2 on Page 66.									

Continued

Modbus and BACnet interoperability

Table 65-1:
Interoperability variable and object names (continued)

Variable name and BACnet object name	Read Only (RO) or Read Write (RW)	Modbus register number*	BACnet Object Type and Instance	LonTalk variable names**	Description	Units		Range	
						I-P units	SI units	I-P units	SI units
Faults and alarms (continued)									
Overcurrent	RW	DV-53 53	BV-53	nvoAlrmOverCur 1	See Table 40-1, Alarms menu	-	-	-	-
Supply water failure	RW	DV-54 54	BV-54	nvoAlrmSupplyH201					
Excessive foaming	RW	DV-55 55	BV-55	nvoAlrmFoaming 1					
Overcurrent 2	RW	DV-57 57	BV-57	nvoAlrmOverCur2					
Supply water 2 failure	RW	DV-58 58	BV-58	nvoAlrmSupplyH202					
Low inlet pressure	RW	DV-61 61	BV-61	nvoAlrmInPress					
High outlet pressure	RW	DV-62 62	BV-62	nvoAlrmOutPress					
Pressure_sensor_out_of_range	RW	DV-63 63	BV-63	nvoAlrmPressSense					
Excessive TDS during fill	RW	DV-64 64	BV-64	nvoAlrmHighTDS					
Pump station cannot run	RO	DV-66 66	BV-66	nvoAlarmHPSsys	HPS redundant system cannot run				
XV: Condensate clearing failure	RW	DV-68 68	BV-68	N/A	XV has failed to clear the header of condensate				
XV: 2 position valve failure	RW	DV-69 69	BV-69	N/A	XV 2 position valve end switch failed to close while the valve was powered				

* See Note 1 on Page 66.

** See Note 2 on Page 66.

Continued

Modbus and BACnet interoperability

Table 66-1:
Interoperability variable and object names (continued)

Variable name and BACnet object name	Read Only (RO) or Read Write (RW)	Modbus register number*	BACnet Object Type and Instance	LonTalk variable names**	Description	Units		Range	
						I-P units	SI units	I-P units	SI units
Messages									
GTS: Replace ignitors soon Electric: Replace contactors WM: Replace UV lamp	RW	DV-38 38	BV-38	nvoMsgReplCntctr	See Table 36-1, Diagnostics menu	-	-	-	-
Service unit	RW	DV-39 39	BV-39	nvoMsgSrviceUnit					
Drain pending	RW	DV-40 40	BV-40	nvoMsgDrainPend					
No airflow	RW	DV-41 41	BV-41	nvoMsgNoDuctAir					
Interlock open	RW	DV-42 42	BV-42	nvoMsgllockOpen					
Freeze drain	RW	DV-43 43	BV-43	nvoMsgFreezDrain					
End of season drain active	RW	DV-44 44	BV-44	nvoMsgEOSactive					
Temp comp on	RW	DV-45 45	BV-45	nvoMsgTempCompOn					
Clean probes	RW	DV-46 46	BV-46	nvoMsgCleanProbe					
Duct HL trip	RW	DV-47 47	BV-47	nvoMsgDuctHLtrip					
Duct HL span	RW	DV-48 48	BV-48	nvoMsgDuctHLspan					
Insufficient water flow	RW	DV-49 49	BV-49	nvoMsgH2Ocutout					
Boiling temp calibrated	RW	DV-50 50	BV-50	nvoMsgBoilTempCl					
Check cylinder, end of life	RW	DV-56 56	BV-56	nvoMsgChkCyl1					
Check cylinder 2, end of life	RW	DV-59 59	BV-59	nvoMsgChkCyl2					
Main enable open	RW	DV-60 60	BV-60	nvoMsgMainEnb					
Excessive TDS during fill	RW	Dv-65 65	BV-65	nvoMsgHighTDS					
XV: Clearing condensate	RO	DV-67 67	BV-67	N/A	XV is attempting to clear condensate out of the header				
Notes: 1. Modbus Input Registers (IR1-IR44) 16 bit read only Modbus Holding Registers (HR1-HR21) 16 bit read/write Modbus Discrete Input Registers (DI1-DI7) single bit read only Modbus Coil Registers (DV1-DV69) single bit read/write 2. nvi LonTalk SNVTs are write-only; nvo are read-only									

Troubleshooting guide

SOLVING ISSUES

Anden Technical Support:
800-972-3710

1. Review issues, possible causes and recommended actions.

The troubleshooting guide on the following pages presents issues, possible causes and recommended actions for typical issues.

2. Review tank or dispersion manuals.

If you have a tank-related or dispersion-related issue, you may also need to refer to those specific product manuals.

3. If you're still having issues, call Anden.

If the troubleshooting guide does not help you solve your issue, call Anden with the following information available:

- Product name and serial number
You'll find this information on the humidifier or control cabinet.
- Issue definition
Example: water leaking, low humidity, high humidity, etc.
- Alarms or Messages Log items (if applicable)
Example: Tank temp, probe wiring, etc.
- Time issue began
Example: Always, after remodel, after a change in weather, etc.
- System changes
Example: Pressure, new boiler, new service, new controller, relocation, change in maintenance, etc.

CALLING ANDEN TECHNICAL SUPPORT

Have the following information ready before calling:

Vapor-logic firmware version _____

Humidifier model number _____

Humidifier serial number _____

Issue definition _____

Alarms Log items _____

Messages Log items _____

Time issue began _____

Recent system changes _____

Troubleshooting guide

Table 68-1:
Troubleshooting guide

	Issue	Possible causes	Actions
Power issues	Green power indicator light is off.	• No control voltage	• Check for proper supply voltage.
		• Heater fuses open	• Check heaters and replace fuses.
		• Transformer secondary circuit breaker tripped	• Check for wiring shorts; reset breaker.
	No remote indication of alarm light No remote activation of fan	• Dry contact or triac connection not programmed from Setup menu	• Go to the programmable outputs section of Setup menu to program dry contacts.
		• Field wiring not installed	• Provide field wiring.
		• Field-supplied remote fault indicator lamp is burned out	• Check if at remote indicator light is burned out; replace if needed.
	No readable information on keypad/display	• Remote fault Vapor-logic dry contact is not switching	• Check dry contact continuity (Vapor-logic terminal P12) for contact closure.
		• No power or incorrect voltage to Vapor-logic board	• Check main power supply. • Reset control transformer circuit breaker if tripped. • Reset thermal cutout if tripped. • Low limit thermostat is not satisfied (outdoor enclosure only).
	Keypad/display does not energize	• Modular communication cable is disconnected	• Connect modular cable.
		• Nonexistent supply voltage to unit	• Check main fuse. • Check main line safety switches. • Check heater fuses.
		• Nonexistent 24 VAC supply	• Check for proper supply. • Verify proper transformer voltage characteristics. • Verify proper wiring of transformer. • Check for control circuit voltage, 24 VAC. If voltage is not present, check transformer circuit breaker. Reset if needed.
	Display is completely black	• Humidifier over-temperature thermostat open	• Reset manual switch located above heater below terminal cover.
		• Keypad/display is overheated	• Cool the keypad.
		• Communication cable not connected	• Connect cable.
		• Defective cable	• Replace cable.
• Defective keypad		• Replace.	
	• Defective control board	• Contact Anden.	

Continued

Troubleshooting guide

Table 69-1:
Troubleshooting guide (continued)

	Issue	Possible causes	Actions
Transmitter or humidistat issues	Alarm: RH signal out of range	When transmitter or humidistat alarms appear, possible causes are: <ul style="list-style-type: none"> • Open, shorted, or incorrect wiring • Incorrect signal • Ground loop • Signal exceeds range limits. Correct input signals are: 4-20 mA, or 0-16 VDC 	<ul style="list-style-type: none"> • Check voltages at board terminals. <ul style="list-style-type: none"> <u>At terminal P11</u> <ul style="list-style-type: none"> – RH signal: 2-10 VDC. – Dew point signal: 2-10 VDC. – Demand signal: 0-16 VDC. <u>At terminal P13</u> <ul style="list-style-type: none"> – Duct high limit signal: 0-21 VDC, 2-10 VDC. <u>At terminal P14</u> <ul style="list-style-type: none"> – Auxiliary temp sensor or temperature compensation sensor: 2-10 VDC. • Check output on transmitter: <ul style="list-style-type: none"> – If there is no output, replace transmitter. – Verify output is 4-20 mA. – Calibrate transmitter or humidistat if necessary. • Isolation control board by others may not be compatible. Consult Anden.
	Alarm: Dew point signal out of range		
	Alarm: Demand signal out of range		
	Alarm: Duct RH signal out of range		
	Alarm: No SDU airflow	• SDU blower or airflow proving switch is incorrectly wired	• Check SDU for proper wiring.
• SDU blower cover is off		• Install cover.	
• SDU blower motor is inoperable (SDU fan does not start)		• Replace SDU blower.	
• Breaker tripped		• Reset breaker.	

Continued

Troubleshooting guide

Table 70-1:
Troubleshooting guide (continued)

Issue	Possible causes	Actions	
Filling issues	Alarm: Excessive fill time	Tank is not full.	
	Alarm: Excessive refill time		
		<ul style="list-style-type: none"> • Fill and drain valve wiring reversed 	<ul style="list-style-type: none"> • Correct wiring.
		<ul style="list-style-type: none"> • Low water supply pressure 	<ul style="list-style-type: none"> • Verify water pressure is 25 psi (552 kPa) minimum.
		<ul style="list-style-type: none"> • In-line strainer plugged 	<ul style="list-style-type: none"> • Clean as needed.
		<ul style="list-style-type: none"> • Humidifier cover interlock switch improperly wired 	<ul style="list-style-type: none"> • Correct wiring.
		<ul style="list-style-type: none"> • Fill valve not open 	<ul style="list-style-type: none"> • If 24 VAC is present across fill valve coil, replace valve.
		<ul style="list-style-type: none"> • Fill valve not wired properly to control board 	<ul style="list-style-type: none"> • Verify proper fill valve wiring at terminal P17 (fill, drain). • Test operation by going to the Test section under the Diagnostics menu.
		<ul style="list-style-type: none"> • Inlet water needle valve closed or plugged 	<ul style="list-style-type: none"> • Check if needle valve is open and free of sediment.
		<ul style="list-style-type: none"> • Fill valve with incorrect operating voltage 	<ul style="list-style-type: none"> • Verify valve coil is 24 VAC.
		<ul style="list-style-type: none"> • Plugged fill valve 	<ul style="list-style-type: none"> • Remove fill valve and check for foreign material plugging the valve.
		<ul style="list-style-type: none"> • Fill valve installed backward 	<ul style="list-style-type: none"> • Check arrow direction on valve; or "In" should be visible on fill valve body.
		<ul style="list-style-type: none"> • Excessive water hammer can bend a needle valve and make it difficult to open 	<ul style="list-style-type: none"> • Replace valve, if needed. • Install a water supply line shock arrester.
		<ul style="list-style-type: none"> • Orifice after fill valve may be plugged 	<ul style="list-style-type: none"> • Service valve strainer and orifice assembly.
		<ul style="list-style-type: none"> • Drain valve leaking water 	<ul style="list-style-type: none"> • Verify drain is in the Auto position and is closed.
		<ul style="list-style-type: none"> • Missing probe rod 	<ul style="list-style-type: none"> • Replace missing probe rod if possible; otherwise, replace probe rod assembly.
		Tank is full.	
		<ul style="list-style-type: none"> • Probe malfunctioning 	<ul style="list-style-type: none"> • Clean or replace probe.
		Low water conductivity: <ul style="list-style-type: none"> • Tap/softened water GTS humidifiers and electric humidifiers with heating elements require fill water conductivity to be 30 μS/cm minimum. • AS150 humidifier recommended fill water conductivity is 350 to 1250 μS/cm. 	<ul style="list-style-type: none"> • Add add ¼-½ tab sodium bicarbonate (i.e., Alka Seltzer) to increase water conductivity. Consult Anden for further advice.
		<ul style="list-style-type: none"> • No tank ground 	<ul style="list-style-type: none"> • Install tank ground.
	<ul style="list-style-type: none"> • Fill valve stuck open 	<ul style="list-style-type: none"> • Check valve for foreign matter. 	
	<ul style="list-style-type: none"> • Fill valve installed backward 	<ul style="list-style-type: none"> • Check arrow direction on valve; or "In" should be visible on fill valve body. 	
	<ul style="list-style-type: none"> • Excessive condensate is draining into the tank 	<ul style="list-style-type: none"> • Consult Anden to increase the amount of water that can be converted to steam before receiving a fault. 	
Fill valve cycles on and off frequently (several times per minute)	For AS150 humidifiers, see <i>Check cylinder / high water</i> on Page 47 of Table 45-1.		
	<ul style="list-style-type: none"> • Malfunctioning level control system 	<ul style="list-style-type: none"> • If needed, clean probes. • Check water conductivity. Minimum conductivity for proper operation of level control system is 30 μS/cm. • Verify that probe wiring is correct. 	
	<ul style="list-style-type: none"> • Drain valve not fully closed 	<ul style="list-style-type: none"> • If an obstruction does not allow drain valve to fully close, clean valve. • If there is a broken or weak return spring on drain valve, replace the valve. • Check if 24 VAC is present at valve. If so, check wiring of Vapor-logic control board terminal P17 (drain). 	
	<ul style="list-style-type: none"> • Poor tank ground 	<ul style="list-style-type: none"> • Verify good machine ground. 	

Continued

Troubleshooting guide

Table 71-1:
Troubleshooting guide (continued)

	Issue	Possible causes	Actions
Filling issues	Unit does not fill with water.	<ul style="list-style-type: none"> Malfunctioning fill valve 	<ul style="list-style-type: none"> Unplug probe head. Fill valve should open. If fill valve does not open, verify proper 24 VAC to fill valve. If voltage is present and valve does not open, replace valve or valve coil. Verify that coil is 24 VAC. Verify that valve stem moves freely.
		<ul style="list-style-type: none"> No water supply to fill valve 	<ul style="list-style-type: none"> Check if water supply line strainer is plugged. Verify that manual water line shut-off valve is open and that pressure exists. Check that in-line needle valve is open.
		<ul style="list-style-type: none"> Unit is not in Auto Mode 	<ul style="list-style-type: none"> Change mode to Auto.
		<ul style="list-style-type: none"> Vapor-logic control is in end-of-season drain mode 	<ul style="list-style-type: none"> Check for humidification demand signal at control board.
		<ul style="list-style-type: none"> Inlet water needle valve is closed 	<ul style="list-style-type: none"> Check needle valve.
		<ul style="list-style-type: none"> Unit is in freeze protection draining 	<ul style="list-style-type: none"> Change mode to Auto.
		<ul style="list-style-type: none"> Fill valve stuck in closed position 	<ul style="list-style-type: none"> Recycle power to recycle fill valve closing and opening.
		<ul style="list-style-type: none"> Malfunctioning level control system 	<ul style="list-style-type: none"> See below.
	Fill valve does not close	<ul style="list-style-type: none"> Open drain valve 	<ul style="list-style-type: none"> If automatic drain valve is locked in the manual open position, reset to automatic. Replace valve if there is a broken return spring on the drain valve. Clean or replace drain valve if an obstruction in the valve does not allow complete closure. Close manual drain valve if it is open. If Vapor-logic shorted output to fill valve coil, replace board or drain coil.
		<ul style="list-style-type: none"> Malfunctioning level control system 	<ul style="list-style-type: none"> Check that probe plug is plugged in fully. If needed, clean probe rods. If water conductivity is too low (see below), add ¼-½ tab sodium bicarbonate (i.e., Alka Seltzer) to tank or cylinder water. If this solves the issue, you have low-conductivity water; consult Anden for further advice. <ul style="list-style-type: none"> Tap/softened water GTS humidifiers and electric humidifiers with heating elements require fill water conductivity to be 30 µS/cm minimum. AS150 humidifier recommended fill water conductivity is 350 to 1250 µS/cm. Replace board if Vapor-logic control board is defective. Verify that system is in auto mode. Verify that probe is wired correctly.
<ul style="list-style-type: none"> Fill valve is stuck 		<ul style="list-style-type: none"> Check if fill valve is installed backwards. If yes, repipe. If there is a faulty internal spring or diaphragm in the fill valve, replace valve. Check if there is an obstruction that does not allow valve to seat properly. Clean or replace valve as needed. Check for control voltage across fill valve coil. (Check wiring and controls.) Install water inlet shock arrestor. 	

Continued

Troubleshooting guide

Table 72-1:
Troubleshooting guide (continued)

	Issue	Possible causes	Actions
Draining issues	Alarm: Tank not draining	• Tank drain outlet	• If the humidifier tank drain outlet is plugged, clean.
		• Water detection probes	• Clean probe or replace probe rod assembly.
		• Drain valve wiring	• Check drain valve wiring. • Check to be sure drain valve is wired to Terminal P17 (drain) on control board. • Reset Vapor-logic.
		• Fill valve	• Check for voltage present at the valve. If present, clean or replace valve. • Replace fill valve if water is leaking through.
		• System programmed for manual drain	• Run a test cycle to see if the system activates drain output.
		• Drain line backing up with water • Drain line plugged	• Insufficient drain line pitch. • Insufficient drain line size. See tank manual for drain piping size and pitch requirements.
	Unit does not perform automatic drain sequence	• Humidifier may not have automatic drain system, or automatic drain is disabled	• Inspect unit to verify that an automatic drain valve was furnished. • Go to Setup menu to verify that auto drain/flush is enabled.
		• Drain fault, plugged drain valve, or plugged drain pipe	• Clean drain valve piping.
		• Malfunctioning automatic drain sequence	• Go to Setup menu and check auto drain/flush settings.
		• No power to the automatic drain valve	• Check if 24 VAC is present at terminal block P17 (drain) and at drain valve.
	Unit does not perform end-of-season drain	• Defective automatic drain valve	• If voltage is present at the valve and it still does not open, replace valve.
		• Input signal always has a demand	• Reduce demand signal.
		• Vapor-logic setup	• Verify in Setup menu Vapor-logic is set for end-of-season drain.
	• Drain valve	• Valve not wired, or incorrectly wired, to control board. • Check 24 VAC across valve coil during test cycle.	

Continued

Troubleshooting guide

Table 73-1:
Troubleshooting guide (continued)

	Issue	Possible causes	Actions
Humidity set point issues	Humidity is below desired level	<ul style="list-style-type: none"> Unit is operating but fails to meet required humidity level 	<ul style="list-style-type: none"> Unit undersized; replace with a larger unit or add additional humidifier. Skim duration is too long. If drain valve does not close fully, determine the cause and clean, repair, or replace as needed. If drain pipe water seal is allowing steam to go down the drain, fill P-trap with water or repair as needed. If there is an improper water seal height, increase to the recommended height (see humidifier tank manual for water seal height). If there is excessive internal steam pressure, determine the cause of the high pressure (e.g., high duct static pressure, undersized orifices in dispersion tubes, water, or crushed vapor hose) and correct as required. Replace leaking gasket or vapor hose. Recalibrate if controls are out of calibration. If fill valve is stuck open, repair or replace. If zone valve will not open, repair or replace. Interconnecting steam piping to the dispersion assembly is too long and/or uninsulated (do not insulate steam hose).
		<ul style="list-style-type: none"> No call for humidity from humidistat or from control and high limit humidity transmitters 	<ul style="list-style-type: none"> Low or no signal strength from humidistat. Check for proper wiring. Check humidity transmitters (4 to 20 mA output). Adjust set point if RH or dew point set point is too low.
		<ul style="list-style-type: none"> Excessive outside air volume 	<ul style="list-style-type: none"> Verify proper operation of fans, dampers, VAV systems, etc.
		<ul style="list-style-type: none"> Heating elements not operating 	<ul style="list-style-type: none"> Verify that humidistat is calling for humidity. Check for control voltage if limit controls (airflow proving switch, zone valves, etc.) are not allowing unit to operate. Check fuses and replace if they are blown. Check if the heater over-temperature has been tripped. Reset if necessary.
		<ul style="list-style-type: none"> Humidity control input type not the same as Vapor-logic firmware 	<ul style="list-style-type: none"> Check Vapor-logic control board connections P11 and P13. Consult Anden.
		<ul style="list-style-type: none"> Vapor-logic not in Auto mode 	<ul style="list-style-type: none"> Change mode to Auto.

Continued

Troubleshooting guide

Table 74-1:
Troubleshooting guide (continued)

	Issue	Possible causes	Actions
Humidity set point issues	Humidity above set point	• High entering relative humidity	• Dehumidify.
		• Unit oversized	• Consult Anden.
		• Reduced airflow	• Check fans, dampers, VAV systems, etc.
		• Improperly located humidistat or humidity transmitters	• Relocate, using guidelines in Appendix section of this manual.
		• Malfunctioning controls	• Check for incorrect supply voltage. • Check for incorrect control signal. • Check for improper wiring hookup. • If humidity controller or transmitter are out of calibration or malfunctioning, repair or recalibrate. • Check if SSR/contactor shorted. Repair or replace as needed.
		• Contactor/SSR is stuck closed	• Remove power from humidifier immediately. Contact Anden.
	Hunting (humidity swings above and below desired set point)	• Malfunctioning control system	• If there is a faulty or inaccurate humidity controller or transmitter, repair or replace. • Check for proper Vapor-logic control settings: RH set point, high limit set point, cycle rate, PID tuning, etc. • Relocate poorly located control components. See "Sensor placement" on Page 20. • On SSR units: Control wire and power wires must be physically separated from each other. If they are not, an induced control voltage can occur, causing erratic operation. • Verify that keypad/display modular cable is isolated from power wiring.
		• Air volume varies rapidly	• Stabilize.
		• Air temperature is varying rapidly	• Stabilize to ± 1 °F (± 1 °C).
		• Proportional band is too small and/or integral gain (Ki) is too large	• If RH swings outside PID band, increase PID band using the Setup menu. • Decrease integral gain (Ki) using the Set Up menu.
• On-off control is not adequate		• If controlling the humidifier with an on-off signal, consider changing to controlling with a modulating signal.	

Continued

anden.com
P.O. Box 1467
Madison, WI 53701-1467
800.972.3710 F: 608.257.4357
Printed in USA
©2020 Anden – A Quality brand from Research Products Corporation

