

QUEST 225



- + Digital Controls
- + M-CoRR Technology
- + Industry-Leading Efficiency
- + Superior MERV-13 Air Filtration
- + Integrated Lift and Hang Points

Serial Number _____

Install Date _____

Sold By _____



Patents: thermastor.com/patents

TABLE OF CONTENTS

Safety Precautions	3	7.7 Remote Controls.....	22
1. Intended Application.....	4	7.7A Humidity Control	23
2. Registrations	4	7.8 Defrost Thermostat	23
3. Specifications.....	4	7.9 Condensate Pump Kit.....	23
4. Installation	5	8. Error Codes.....	24
4.1 Location.....	5	Wiring Diagram.....	25
4.2 Electrical Requirements	5	Service Parts List	26
4.3 Condensate Water Removal	6	Optional Parts List	26
4.4 Hanging Diagram	7	Warranty.....	28
4.5 Ducting	8		
4.6 Hard-Wiring	12		
5. Control Options.....	16		
5.1A On Board Dehumidistat	16		
5.2B External Control Options.....	17		
5.2 External Control.....	18		
6. Maintenance	18		
6.1 Standard Air Filter.....	18		
6.2 Impeller Fan Oiling	18		
7. Service.....	19		
7.1 Warranty.....	19		
7.2 Technical Description	19		
7.3 Troubleshooting.....	19		
7.4 Refrigerant Charging.....	21		
7.5 Impeller Fan Replacement.....	21		
7.6 Compressor/Capacitor Replacement	21		
7.6A Checking Compressor Motor Circuits ...	21		
7.6B Replacing a Burnt Compressor.....	22		
7.6C Replacing Compressor-Nonburn Out....	22		



4201 Lien Rd.
 Madison, WI 53704
 1-877-420-1330
 Thermastor.com

© 2023 Therma-Stor LLC

SAFETY PRECAUTIONS

Read the installation, operation and maintenance instructions carefully before installing and operating this device. Proper adherence to these instructions is essential to obtain maximum benefit from your Quest Dehumidifier.

READ AND SAVE THESE INSTRUCTIONS

- » The device is designed to be installed **INDOORS IN A SPACE THAT IS PROTECTED FROM RAIN AND FLOODING.**
- » Install the unit with space to access the back or side panels for maintenance and service. **DO NOT INSTALL UNIT WITH THE SERVICE PANELS INACCESSIBLE.**
- » Avoid directing the discharge air at people, or over the water in pool areas.
- » If used near a pool, spa or water; be certain there is **NO** chance the unit could fall into the water, be splashed and that it is plugged into an outlet that is a **GROUND FAULT INTERRUPT** protected circuit.
- » **DO NOT** use the device as a bench or table.
- » **DO NOT** place the device directly on structural members. Provide vibration isolation in order to minimize operational vibration and/or noise.
- » A drain pan **MUST** be placed under the unit if installed above a living area or above an area where water leakage could cause damage
- » Never operate a unit with a damaged power cord. If the power cord is damaged it must be replaced by the manufacturer, its service agent, or similarly qualified person in order to avoid a hazard.
- » Make all electrical connections in accordance with the current edition of the **NEC ANSI/NFPA 70** and any national and local codes or ordinances that may apply.
- » Maintain a minimum 1ft. (.3m) clearance to avoid obstructing the air return and supply.
- » This appliance is not intended for use by persons (including children) with reduced physical, sensory or mental capabilities, or lack of experience and knowledge, unless they have been given supervision or instruction concerning use of the appliance by a person responsible for their safety. Children should be supervised to ensure that they do not play with the appliance.
- » Not intended for use at altitudes over 6500 ft (2000M).

1. INTENDED APPLICATION FOR QUEST 225

The Quest 225 Dehumidifier is designed to operate in temperatures between 56° and 95°F.

In order to efficiently control humidity levels, the area in which the dehumidifier is to be operated must be free of water intrusion or excessive fresh (outside) air infiltration. Before installing the Quest 225 Dehumidifier, water intrusion and air infiltration problems should be addressed or noted in calculations.

2. REGISTRATIONS

The Quest 225 Dehumidifier units conform to unified standard UL 60225-2-40, CSA C22,2#60225-2-40. US Patents: D570,988 / 8,069,681 / 9,052,132.

3. SPECIFICATIONS @ 80°F/60% RH

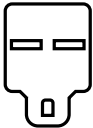
UNIT	QUEST 225 4042800	
BLOWER: (TESTED WITH DUCT COLLARS ON)	650 CFM @ 0.6" WG	
POWER:	1150 Watts	
SUPPLY VOLTAGE:	208V and 230V 1 Phase - 60 Hz	
CURRENT DRAW:	5.3A @ 230V 5.6A @ 208V	
MCA *	8.0A	
MOP *	15A	
RECOMMENDED BREAKER SIZE:	15A	
ENERGY FACTOR:	3.9 L/kWh	
OPERATING TEMP:	56 F Min-95 F Max	
WATER REMOVAL: EFFICIENCY:	225 Pints/Day 8.2 Pints/kWh	
AIR FILTER: MERV-13	Size: 22" x 20" x 2"	
POWER CORD: 10' 14/3 SJTW	NEMA 6-15P, 10' 	
DRAIN CONNECTION:	3/4" Threaded NPT	
REFRIGERANT TYPE: REFRIGERANT AMOUNT:	R410A 4 lb 12 oz	
DIMENSIONS:	Unit	Shipping
WIDTH:	23.6"	25"
HEIGHT:	20.9"	21"
LENGTH:	26.8"	29"
WEIGHT:	130 lb	152 lb

*** MCA = Minimum Circuit Ampacity**

This number provides a qualified electrician with the information needed to determine the minimum wire size used in the circuit that feeds a single dehumidifier.

*** MOP = Maximum Overcurrent Protection**

This number provides a qualified electrician with the value of the maximum size circuit breaker that may be used to protect the circuit that feeds a dehumidifier.

Specifications are subject to change without notice.

4. INSTALLATION

4.1 LOCATION

The Quest 225 Dehumidifier can be installed in a variety of locations to meet the owner's needs as listed below. In all cases keep the following cautions in mind:

- » Place the Quest 225 Dehumidifier on supports that raise the base of the unit 6" above the secondary drain pan so a P-trap can be installed. See Section 4.3.
- » The Quest 225 Dehumidifier may be suspended with steel hanger, straps, or a suitable alternative from structural members, unit must be supported from underneath. Don't hang from sides or ends. See section 4.3.
- » If installing on ground, use included plugs to cover hanging locations on top of the machine.
- » If hanging machine in air, use included plugs to cover holes in base pan for leveling feet.

4.2 ELECTRICAL REQUIREMENTS

The Quest 225 Dehumidifier plugs into NEMA rated receptacles. The amp draw under normal operating conditions is listed on page 4. A ground fault interrupter protected circuit is required.

Install the remote hygrosat in a central area of the structure where it will sense the relative humidity of the structure accurately. Do not install the hygrosat where it may not accurately sense the relative humidity such as near HVAC supply registers, near exterior doors, or near a pool or spa. The installer must supply the wiring between the Quest 225 Dehumidifier and the hygrosat. Be sure to safely route the control wiring to prevent damage during installation. Be careful not to cross the wires when connecting the Quest 225 Dehumidifier and the remote hygrosat.

The remote controls of the Quest 225 Dehumidifier are powered by a low voltage circuit (24 VAC) and must NEVER contact or be connected to a high voltage circuit. The control terminals and remote control are labeled and numbered to prevent confusion. Be sure to consult the electrical schematic in this manual or inside the access panel of the Quest 225 Dehumidifier before making the control connections.

 **CAUTION!** Always disconnect the Quest 225 from a power source when working with the high voltage control wires.

⚠ CAUTION! For proper drainage, the unit must be mounted so the drain outlet is at least 6.75" above the floor drain, and must be fully supported under the base.

4.3 CONDENSATE WATER REMOVAL

Condensate drains by gravity via the drain port. Use 3/4" male NPT PVC pipe. An optional condensate pump kit may be installed if a lift is required to dispose of the condensate. Optional parts list for information on the kit.

FOLLOW DIAGRAM:

QUEST 225

$$H = 4''$$

$$J = 2''$$

$$L = 6.75''$$

Vent:

- » Place vent after the trap.
- » Vent should be open.
- » Height of vent should be higher than drain outlet.

Cap:

- » A clean out can be placed before trap but must be sealed with a cap.

Drain Line:

- » Drain line should go in a downward slope to the drain.
- » 1/4" drop per foot.

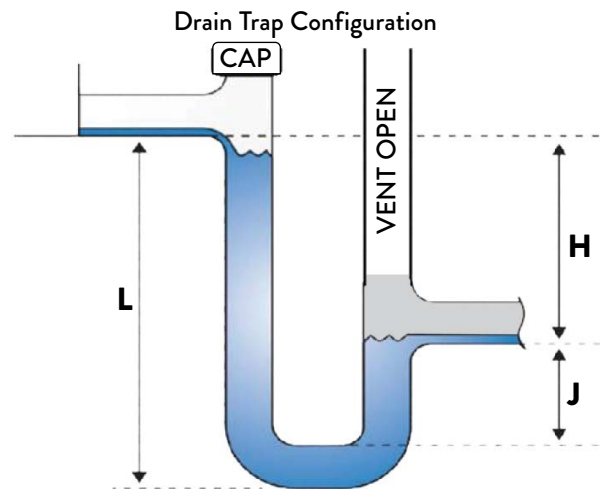

4.4 HANGING DIAGRAM

QUEST 225

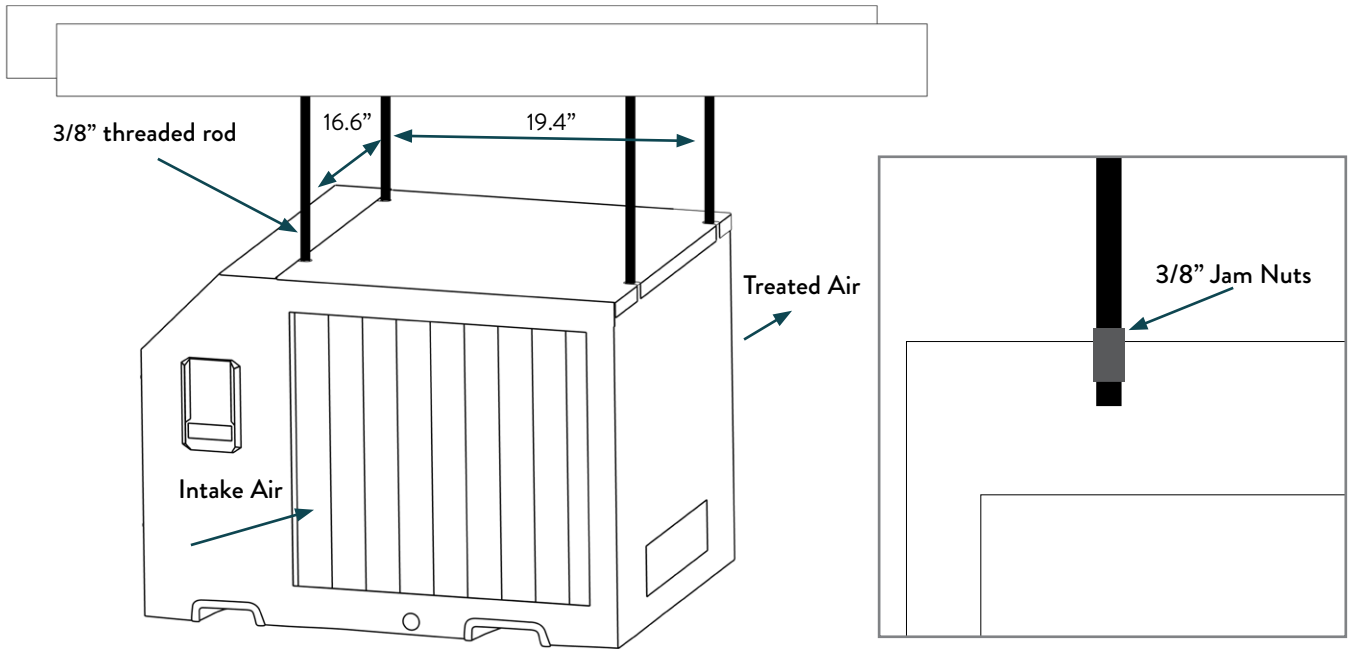

Parts Needed: 4 pieces 3/8" threaded rod (not included)
4 - 3/8" threaded jam nuts (not included)

⚠️ Threaded rods should be engaged no less than 2" into machine.



4.5 DUCTING

Return and supply duct collars are optional accessories for the Quest 225 and not included with the unit.

⚠ CAUTION! Do not connect with a static pressure greater than or equal to +1.0 WG. Contact technical support at (877) 420-1330 for additional details.

DUCTING CONSIDERATIONS:

- » All flexible ducting connected to the Quest 225 should be UL listed.
- » A short piece of flexible ducting on all Quest 225 duct connections is recommended to reduce noise and vibration transmitted to rigid ductwork in the structure.
- » Use a minimum 10" diameter round or equivalent rectangular duct for total duct lengths of up to 25'.
- » Grills or diffusers on the duct ends must not excessively restrict airflow.
- » A length of 8" or more of insulated flex duct or any other vibration isolating material on the outlet of the Quest 225 will reduce air noise from the blower.
- » When ducting two or three areas, use 8" or larger diameter branch ducting. When ducting to four or more areas, use 6" or larger diameter branch ducting. Provisions must be made to provide airflow supply locations to the central return location. Proper air distribution is important to ensure even humidity control and heat distribution throughout the structure.

QUEST 225 SUPPLY AND RETURN DUCT KIT (P/N 4043235)

If factory duct kit accessory was purchased, follow instructions included with duct kit.

If owner chooses to have a licensed HVAC contractor fabricate a duct kit, please follow the drawing below for safe zones for self tapping screws.

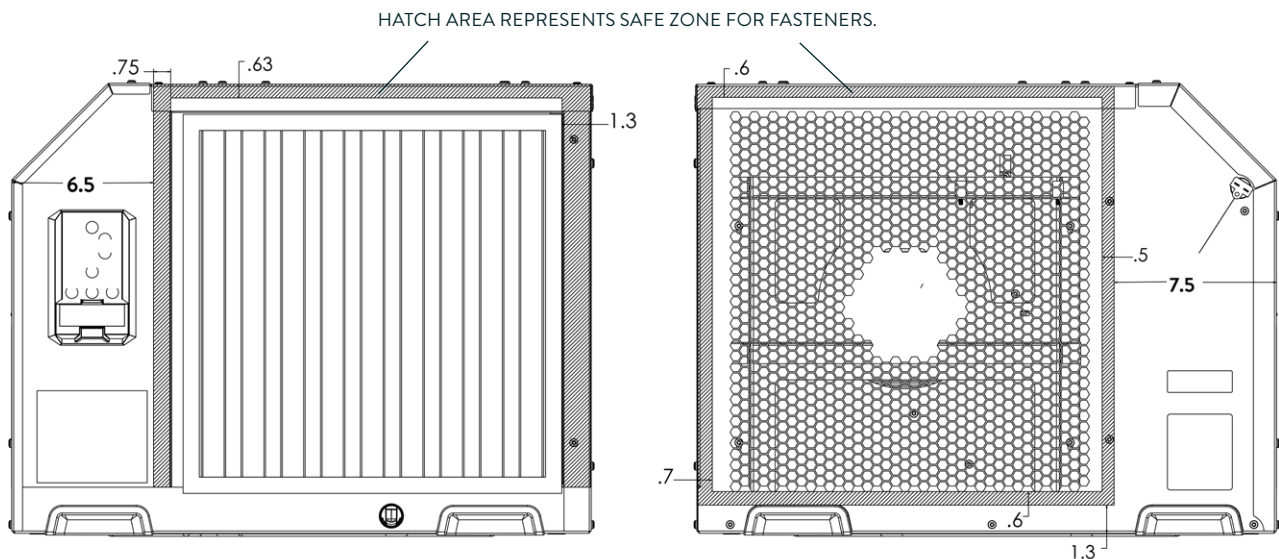

DUCTING TO HVAC OPTIONS

A. HVAC SUPPLY TO SUPPLY

⚠ CAUTION! To avoid the dehumidifier cycling in and out of DEFROST, it is recommended that the leaving air temperature of the A/C coil is not below 55°F. Also, this install is not recommended for climates where the heating system will run during the spring and fall times of year, as this could diminish the water removal capability of the dehumidifier. If the Check Damper is not used, it is important to have the HVAC system fan ON when the dehumidifier is ON to prevent backflow of air.

⚠ WARNING! Due to pressure resistance it is not recommended to use the optional outdoor air intake when installing the dehumidifier supply to supply.

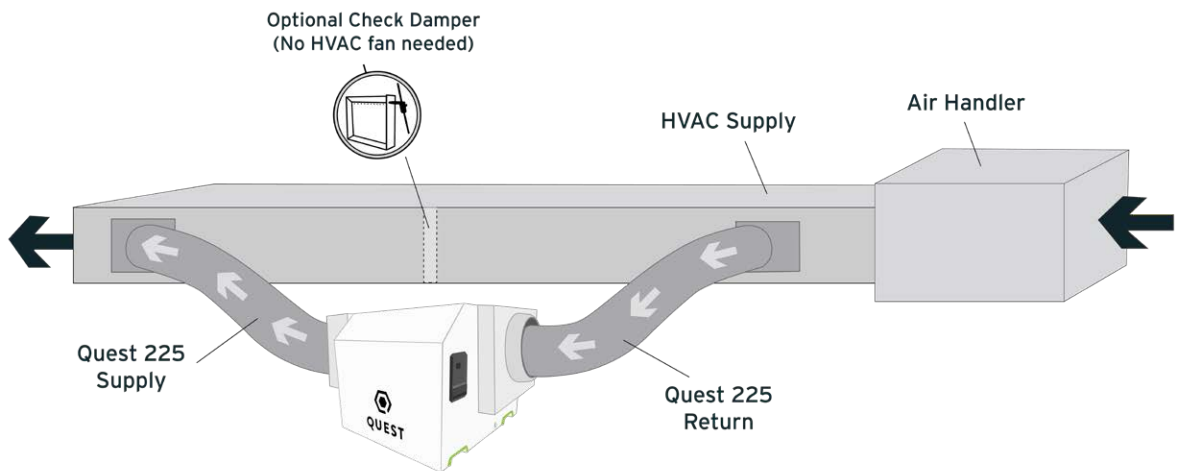

B. DEDICATED RETURN TO SUPPLY

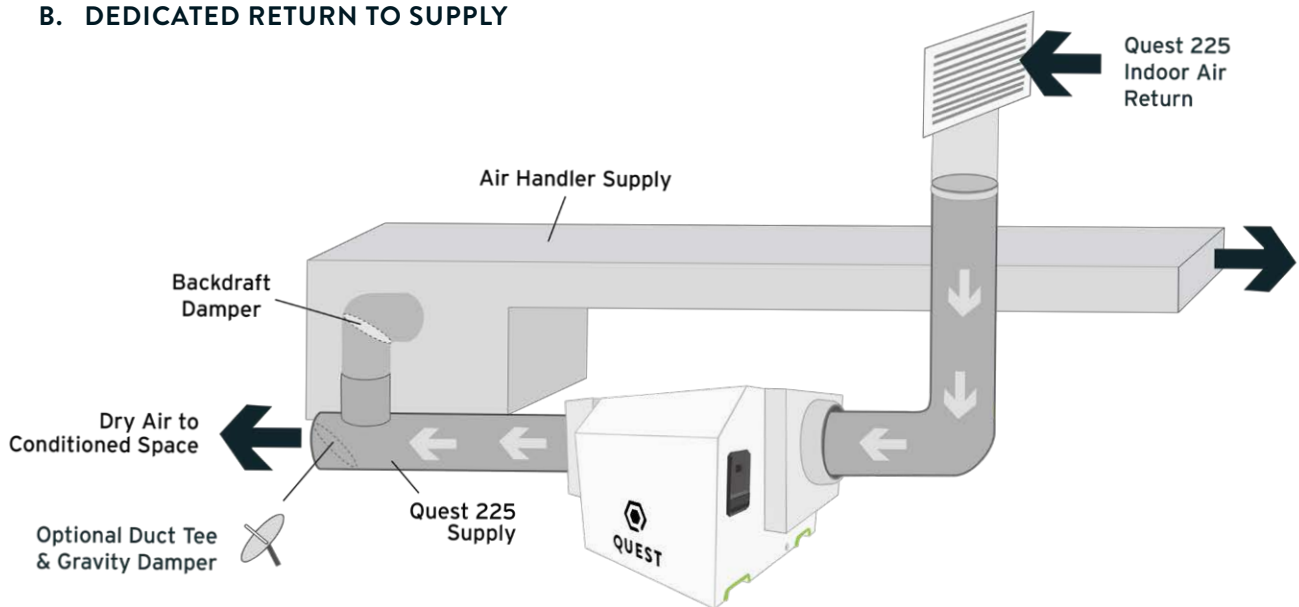

⚠ CAUTION! PLEASE NOTE: Return to Return installs are to be considered last resort options and are not recommended. The dehumidifier will heat the AC cooling coils which diminishes the amount of water the AC system will remove when operating. If this installation is chosen, the dehumidifier must activate the HVAC blower and AC calls need to lock out the dehumidifier from running. Please check your local codes prior to installing.

C. DEDICATED QUEST RETURN TO HVAC RETURN

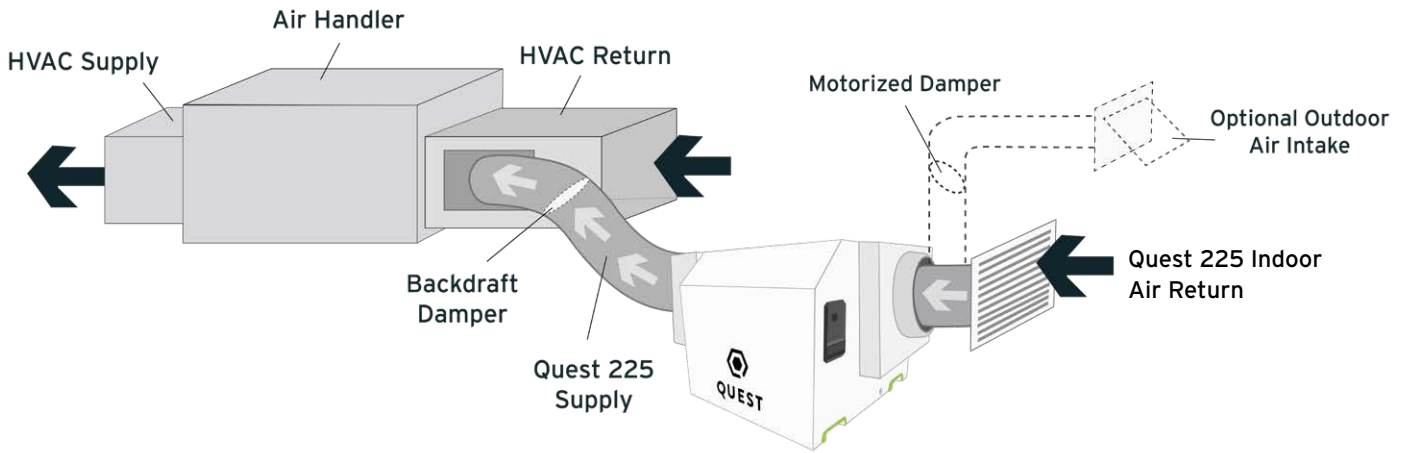

Create a separate return for the Quest 225 Dehumidifier in a central area of the building.

Installing the supply air from the Quest 225 Dehumidifier to the return of the HVAC system requires the HVAC fan to run when the Quest Dehumidifier is operating.

D. HVAC RETURN TO HVAC RETURN

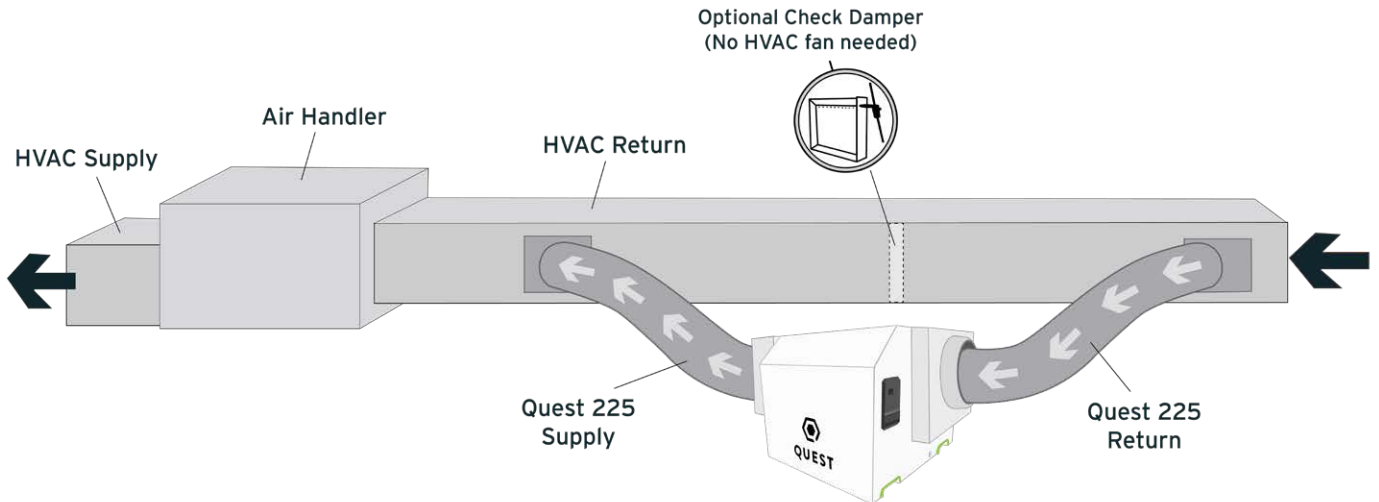

NOTE: If Check Damper is not in place, the HVAC fan must ON when the dehumidifier is in operation.

E. HVAC RETURN TO HVAC SUPPLY

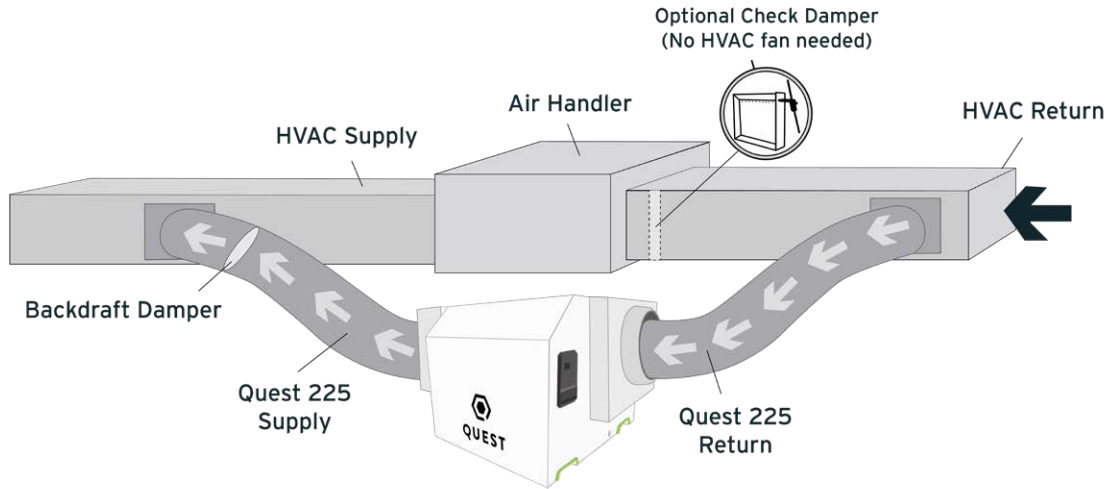

Check damper should be in place between the Return and Supply connections of the dehumidifier.

If the Check Damper is not in place, the HVAC fan must be ON when the dehumidifier is in operation.

Anything greater than 0.4" of static requires HI fan setting. Anything greater than 0.7" of static requires HI override (99). Anything greater than 0.9" is not recommended.

F. NO EXISTING DUCTWORK INSTALLATION

When installing the Quest 225 Dehumidifier in a structure that does not have a forced-air HVAC system, a single return for the dehumidifier should be installed in a central location. The supply air should be ducted back into the space you want to dry. Proper air distribution is important for optimal performance of the dehumidifier.

Install a 6" insulated duct from outside, teeing into the 14" return duct of the Quest 225 Dehumidifier to provide outdoor air ventilation (optional).

An 14" diameter duct is recommended for branches to larger areas.

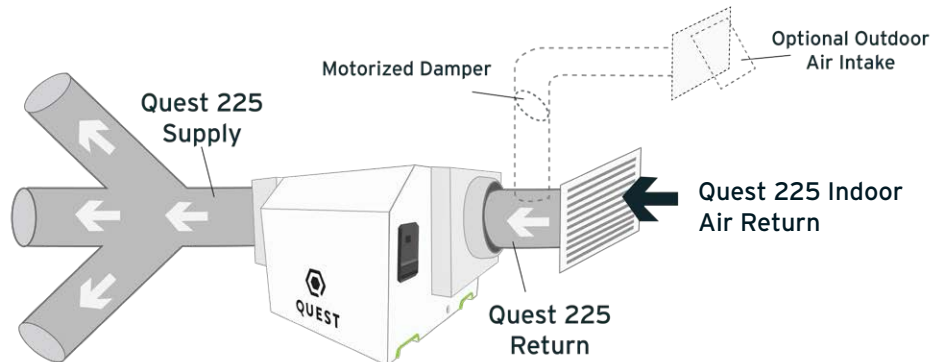

4.6 HARD-WIRING INSTRUCTIONS

⚠ WARNING! Servicing the Quest 225 Dehumidifier, with its high pressure refrigerant system and high voltage circuitry presents a health hazard which could result in death, serious bodily injury, and/or property damage. Only qualified service people should service this unit.

TOOLS REQUIRED:

- » T25 Torx Driver
- » 11/32" Driver

Following all local and national electrical codes and standards, route electrical service to the location that the dehumidifier will be installed.

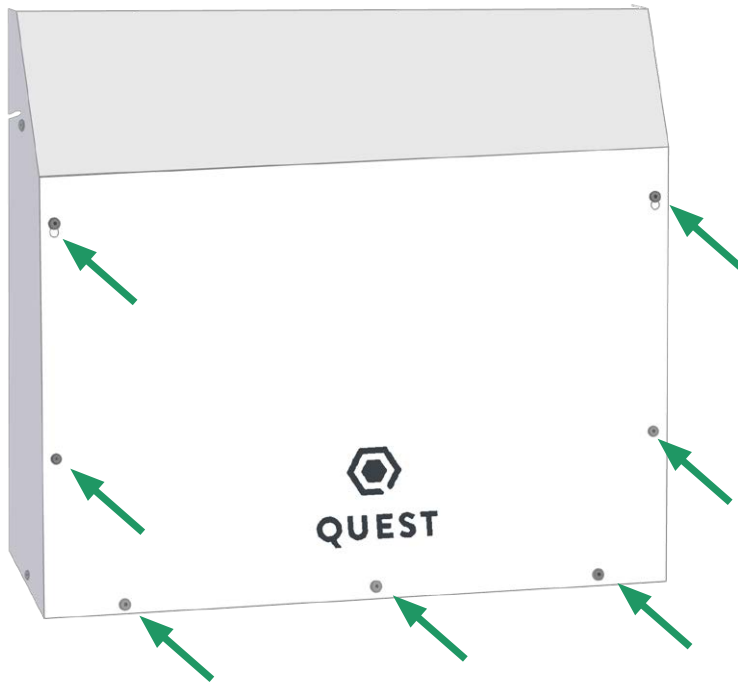

Remove 7 screws on access panel using T25 Torx driver, remove panel.

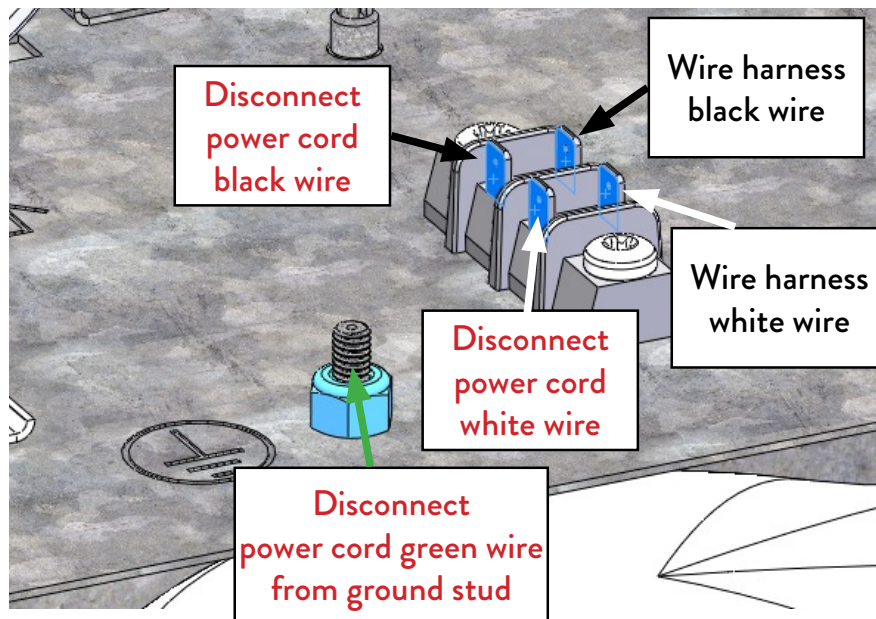

Disconnect POWER CORD BLACK wire from terminal

Disconnect POWER CORD WHITE wire from terminal.

Use 11/32" driver to remove nut from ground stud and disconnect POWER CORD GREEN wire from ground stud.

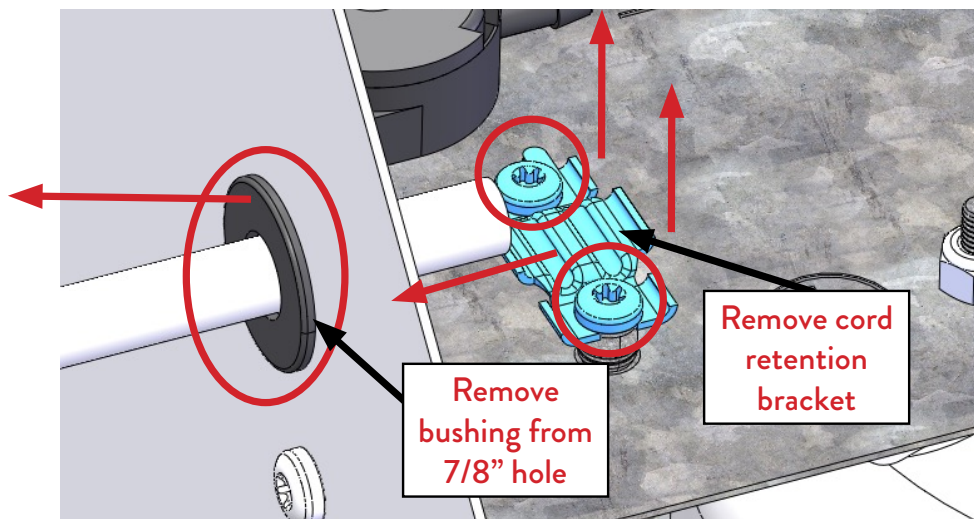

Remove the 2 screws holding the cord retention bracket using T25 Torx driver and remove retention bracket.

Remove power cord and black bushing.

Route incoming power service wires through 7/8" hole and secure using clamps intended for the conduit or cable.

Hardwire kit with jumper wires can be found in the pack part kit.

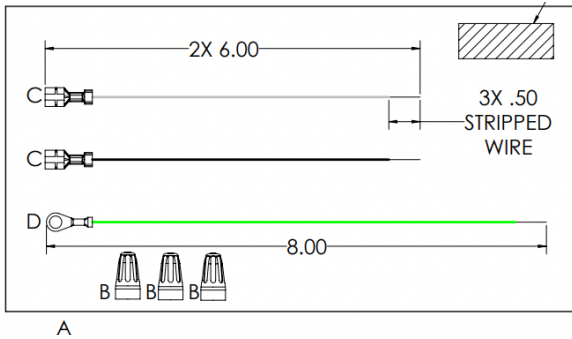

Connect BLACK and WHITE jumper wires to terminal block as shown.

Place GREEN jumper wire ring terminal on ground stud and use 11/32" driver to secure nut to stud.

Attach incoming service LINE 1 wire to BLACK jumper wire with the provided wrenut.

Attach incoming service LINE 2 wire to WHITE jumper wire with the provided wrenut.

Attach incoming service GROUND wire to GREEN jumper wire with the provided wrenut.

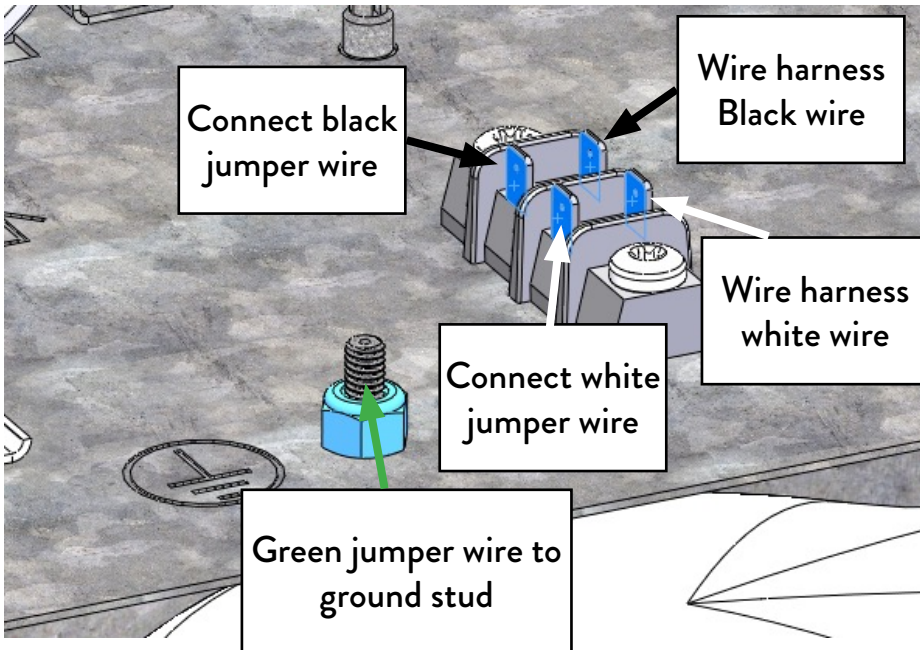

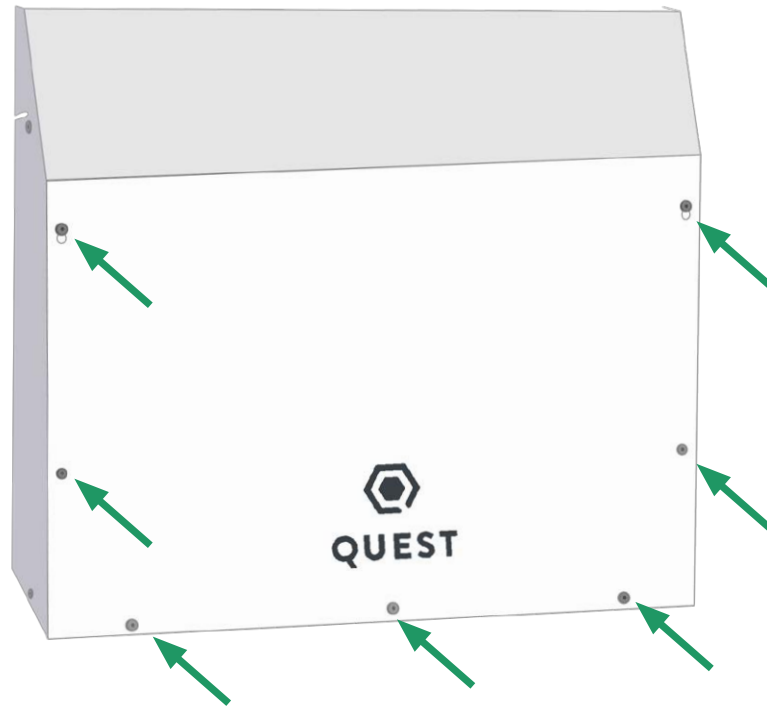

Replace access panel using T25 Torx driver to secure 7 screws.

5. CONTROL OPTIONS

The Quest 225 Dehumidifier can be controlled by its on board dehumidistat or with an external control using its low voltage terminal block.

5.1A QUEST 225 ONBOARD DEHUMIDISTAT

Off Mode: Fan, Compressor, Display and all LEDs are off

To Turn Unit On: Press the power button

On Mode: Display is on and shows the set point (Initial set point: 55% RH)

To Change Set Point:

- » Press the up or down arrow once, the 2-digit display will begin to blink.
- » Adjust to desired RH. Each push of the button will change the SP 1% RH.
- » After 6 seconds without a button being pushed the number showing will become the new SP

DEFROST LIGHT



- » The light over the snowflake will light up when defrost is occurring (ice is detected on coils). The fan will be on, and the compressor will be off during defrost.

FILTER RESET



- » Filter reset button will light up after the fan has been running for 2,000 hours, or if the pressure switch detects excessive pressure build-up indicating that the filter must be changed.
- » After changing the filter, press and hold the filter reset button to reset the 2,000-hour timer. Light flashes while button is held.

DARK MODE



- » Press the Dark Mode button to activate Dark Mode.
- » Once Dark Mode is activated, lights will remain on for 20 seconds before the unit's hygostat will go dark. Dark Mode light will flash for 3 seconds before unit goes dark.
- » Unit will temporarily leave dark mode when any button is pushed and will go dark 20 seconds after the last button is pushed.
- » To turn off Dark Mode, press the Dark Mode button and ensure light above Dark Mode button is off.
- » This mode is for applications where the user would like the unit to operate without emitting any light.

FAN



Pressing the Fan button alternates the unit between 3 fan speeds:

- » **(Hi)gh:** Increased fan speed to be used exclusively in ducted applications. Deactivates filter-life compensation mode.
- » **(Au)to:** Default fan speed. Filter-life compensation mode active.
- » **(Lo)w:** Decreased fan speed that lowers the volume and performance of the unit. Deactivates filter-life compensation mode.

Filter-life compensation mode measures the static pressure increase due to the filter particulate build-up and increases fan speed to maintain optimum airflow and performance.

Changing Max Fan Speed

- » Hold the FAN button for 3 seconds, the 2-digit display will begin to flash.
- » Once the display is flashing, the maximum fan speed can be adjusted 1% at a time (in the range of 20-99%).
- » The new maximum fan speed can be locked by not pressing any buttons for 6 seconds or by pressing the FAN button.
- » This will disable filter life compensation functionality.

TERMINAL CONTROL



- » When the Terminal Control button is pressed, the display will show "tc".
- » The Terminal Control button is used to activate the "DEHUM" input on the terminal block. (see section 5.1B)
- » This must be activated when an external control is used to control RH. When Terminal Control is active, the internal RH sensor is disabled.

5.1B QUEST 225 EXTERNAL CONTROL OPTIONS

Quest offers three external control options: Quest DEH 3000R and Honeywell Humidipro.

NOTE: 22 ga wire needed for sensor

4028531
QUEST DEH 3000R CONTROL
WIRING DIAGRAM

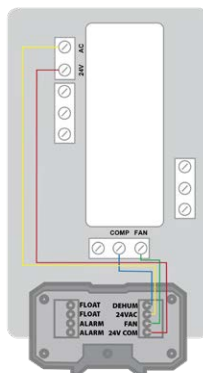

4041649
HONEYWELL HUMIDIPRO
WIRING DIAGRAM

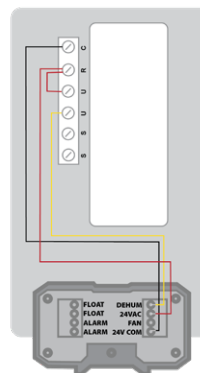

5.2 QUEST 225 EXTERNAL CONTROL

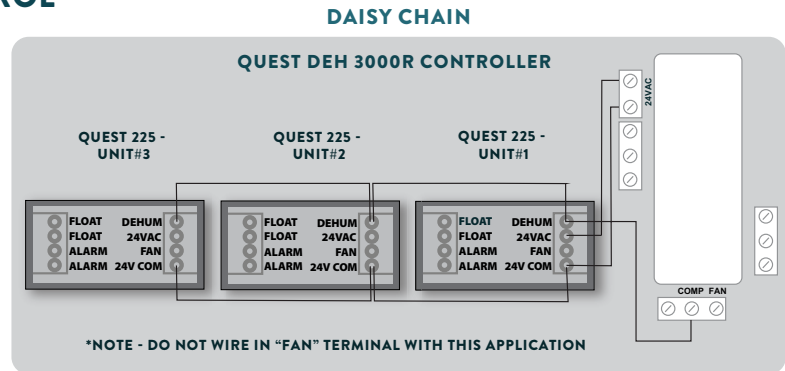

To order, contact your dealer, call 1-877-420-1330, or go to: www.questclimate.com/product-category/accessories

Remove the cover from the user interface to expose the terminal block inputs & outputs.

Quest 225 Terminal Block Control Operations:

- DEHUM:** Dehumidification (Fan and Compressor) Control Input.
- 24VAC:** Transformer High Side Output to External Control.
- Fan:** Fan Control Input.
- 24V COM:** 24VAC Power Transformer Neutral Side Output to External Control.
- FLOAT:** External Low Voltage Float Switch or Water Sensor Input (Use Normally Closed Switch).
- FLOAT:** External Low Voltage Float Switch or Water Sensor Input (Use Normally Closed Switch).
- Alarm:** Normally Closed Relay Output - Indicates when dehumidifier is in an alarm state.
- Alarm:** Normally Closed Relay Output - Indicates when dehumidifier is in an alarm state.

NOTE: Alarm terminals are used to interface with a remote alarm or building automation system. The terminals switch when the unit has a malfunction and are factory set to "normally closed" but can be changed to "normally open".

6. MAINTENANCE

⚠ WARNING! NOTE: Do not operate the unit without the filter or with a less effective filter. The heat exchange coils inside the unit could become clogged and require disassembly to clean. Filter non-compliance invalidates the product warranty.

6.1 STANDARD AIR FILTER

The Quest 225 Dehumidifier ships with a standard MERV-13 efficient pleated fabric filter. This filter should be checked every six months. Operating the unit with a dirty filter will reduce dehumidifier capacity and efficiency and may cause the compressor to cycle off and on unnecessarily on the defrost control.

To access the air filter, remove the filter access panel from the end of the Quest 225 Dehumidifier. The filter should be readily visible and can be removed by pulling it straight out of the Quest 225 Dehumidifier.

We recommend changing the filter at least every 6 months. For agriculture we recommend changing the filter with every grow cycle.

6.2 IMPELLER FAN OILING

The impeller fan motor is factory lubricated for many years of normal operation, and no further oiling is required.

7. SERVICE

⚠ WARNING! Servicing the Quest 225 with its high pressure refrigerant system and high voltage circuitry presents a health hazard which could result in death, serious bodily injury, and/or property damage. Only qualified service people should service this unit.

7.1 WARRANTY

A warranty certificate has been enclosed with this unit; read it before any repair is initiated. If a warranty repair is required, call the factory first at 1-877-420-1330 for warranty claim authorization and technical assistance.

7.2 TECHNICAL DESCRIPTION

The Quest 225 Dehumidifier uses a refrigeration system similar to an air conditioner's to remove heat and moisture from incoming air, and add heat to the air that is discharged.

Hot, high-pressure refrigerant gas is routed from the compressor to the condenser coil. The refrigerant is cooled and condensed by giving up its heat to the air that is about to be discharged from the unit. The refrigerant liquid then passes through a filter/drier and expansion device which causes the refrigerant pressure and temperature to drop. It next enters the evaporator coil where it absorbs heat from the incoming air and evaporates. The evaporator operates in a flooded condition, which means that all the evaporator tubes contain liquid refrigerant during normal operation. A flooded evaporator should maintain nearly constant pressure and temperature across the entire coil, from inlet to outlet.

The compressor collects the cool refrigerant gas and compresses it to a high pressure and temperature to repeat the process.

7.3 TROUBLESHOOTING

Unit Test to determine problem:

1. Detach any exterior control wiring by removing terminal block but jump both FLOAT terminals together.
2. Reinstall terminal block into the control.
3. Plug unit in to known good power outlet. 208 to 240 volts.
4. Power unit on by pressing power button on top of control.
5. Make sure the Terminal Control light is NOT illuminated. Press button to change.
6. Press down arrow to set the unit below 20% until "on" is displayed. This will force the unit on.
7. Listen for the fan to turn on almost immediately.
8. Wait 1 to 2 minutes for the compressor to turn on.
9. If these tests work, the problem is most likely in the control or field wiring.

Neither fan nor compressor running. Dehumidification is being called for. No fan call.

1. Unit unplugged or no power to outlet.
2. Humidity control set too high.
3. Loose connection in internal or control wiring.
4. Bad control or power board.
5. Defective control transformer.

Compressor is not running. Dehumidification is being called for. No fan call.

1. Defective compressor run capacitor.
2. Loose connection in compressor circuit.
3. High pressure switch open or unplugged.
4. Defective compressor.
5. Compressor relay defective or unplugged.
6. Temp & RH sensor reading above 120°F or below 40°F, or sensor is bad or unplugged.

Compressor cycles on and off. Dehumidification is being called for. No fan call.

1. Low ambient temperature and/or humidity causing unit to cycle through defrost mode.
2. Evaporator temp sensor bad or unplugged.
3. Defective compressor.
4. High pressure switch defective.
5. Dirty air filter(s) or air flow restricted.
6. Bad control or power board.

Fan is not running. Dehumidification or fan is being called for.

1. Loose connection in fan circuit.
2. Obstruction prevents fan impeller rotation.
3. Defective fan.
4. Bad control or power board.

Low dehumidification capacity (evaporator is frosted continuously). Dehumidification is being called for.

1. Evaporator temp sensor bad or unplugged.
2. Low refrigerant charge.
3. Dirty air filter(s) or air flow restricted.
4. Excessively restrictive ducting connected to unit.

Unit removes some water, but not as much as expected.

1. Air temperature and/or humidity have dropped.
2. Humidity meter and or thermometer used are out of calibration.
3. Unit has entered defrost cycle.
4. Air filter dirty.
5. Low refrigerant charge.
6. Air leak (eg. loose cover or ducting leaks).
7. Defective compressor.
8. Restrictive ducting.
9. Unit is in (Lo)w fan mode.
10. Evaporator temp sensor bad or unplugged.
11. Temp and RH sensor off calibration. Reading lower than actual.
12. Air pressure switch off calibration.

Filter Change Light illuminated (too frequently):

1. Change filter if dirty.
2. Hold filter change button to reset filter life hours.
3. Ducting configuration causing poor airflow. Disable filter change light by selecting a different fan speed.

7.4 REFRIGERANT CHARGING

If the refrigerant charge is lost due to service or a leak, a new charge must be accurately weighed in. If any of the old charge is left in the system, it must be recovered before weighing in the new charge. Refer to the unit nameplate for the correct charge weight and refrigerant type.

7.5 IMPELLER FAN REPLACEMENT

The motorized impeller fan is a unitary assembly consisting of the motor and impeller fan. If defective, the complete assembly must be replaced.

1. Unplug the power cord.
2. Remove the access panel, and top panel.
3. Remove the screws attaching the impeller fan support bracket to the base.
4. Disconnect the impeller fan leads inside the electric box.
5. Remove fan/bracket assembly by removing 3 screws from the bracket and inlet ring assembly.
6. Remove the defective impeller fan from the bracket and replace with it with the new impeller fan.
7. Reassemble the new impeller fan by reversing the above procedure. Note: There are two pins on the backside of the cabinet that must align with the two holes in the impeller fan support bracket.

7.6 COMPRESSOR/CAPACITOR REPLACEMENT

This compressor is equipped with a run capacitor, but no start capacitor or start relay.

7.6A CHECKING COMPRESSOR MOTOR CIRCUITS

Perform the following tests if the impeller fan runs but the compressor does not with a call for dehumidification.

1. Remove the cabinet side to gain access to the electrical components.
2. Plug in the unit and turn the humidity control to ON. Check for volts from compressor black wires on compressor relay to white wire on compressor capacitor using an AC voltmeter.
 - 2.1 If correct voltage is present, go to next step.
 - 2.2 If no voltage, there may be a loose connection in the compressor circuit. Test each component for continuity. See the appropriate section if a defect is suspected.
3. Unplug the unit and then disconnect the connector from the side of the compressor. Using an ohmmeter, check continuity between the points listed below.
4. Compressor terminals C and S: No continuity indicates an open start winding. The compressor must be replaced. Normal start winding resistance is 3 to 7 ohms.
5. Compressor terminals C and R: No continuity indicates an open run winding. The compressor must be replaced. Normal run winding resistance is .5 to 2 ohms.
6. Compressor terminal C and compressor case: Continuity indicates a grounded motor. The compressor must be replaced.
7. Disconnect the wires from the run capacitor. The capacitor is shorted and must be replaced if continuity exists between any terminal and ground.

8. Using capacitor or MFD setting on meter test between both capacitor terminals. Compare reading to capacitor spec on capacitor.
9. If the above test pass but the compressor does not work, the compressor has an internal mechanical defect and must be replaced.

7.6B REPLACING A BURNT COMPRESSOR

The refrigerant and oil mixture in a compressor is chemically very stable under normal operating conditions. However, when an electrical short occurs in the compressor motor, the resulting high temperature arc causes a portion of the refrigerant oil mixture to break down into carbonaceous sludge, a very corrosive acid, and water. These contaminants must be carefully removed otherwise even small residues will attack replacement compressor motors and cause failures.

The following procedure is effective only if the system is monitored after replacing the compressor to insure that the clean up was complete.

1. This procedure assumes that the previously listed compressor motor circuit tests revealed a shorted or open winding.
2. Remove and properly dispose of the system charge. **DO NOT** vent the refrigerant or allow it to contact your eyes or skin.
3. Remove the burned out compressor. Use rubber gloves if there is any possibility of contacting the oil or sludge.
4. To facilitate subsequent steps, determine the type of burn out that occurred. If the discharge line shows no evidence of sludge and the suction line is also clean or perhaps has some light carbon deposits, the burn out occurred while the compressor was not rotating. Contaminants are therefore largely confined to the compressor housing. A single installation of liquid and suction line filter/driers will probably clean up the system.

If sludge is evident in the discharge line, it will likely be found in the suction line. This indicates the compressor burned out while running. Sludge and acid have been pumped throughout the system. Several changes of the liquid and suction filter/driers will probably be necessary to cleanse the system.

5. Correct the system fault that caused the burn out. Consult the factory for advice.
6. Install the replacement compressor with a new capacitor and an oversized liquid line filter.
In a running burn out, install an oversized suction line filter/drier between the accumulator and compressor. Thoroughly flush the accumulator with refrigerant to remove all trapped sludge and to prevent the oil hole from becoming plugged. A standing burn out does not require a suction line filter/drier.
7. Evacuate the system with a good vacuum pump and accurate vacuum gauge. Leave the pump on the system for at least an hour.
8. Operate the system for a short period of time, monitoring the suction pressure to determine that the suction filter is not becoming plugged. Replace the suction filter/drier if pressure drop occurs. If a severe running burn out has occurred, several filter/driers may have to be replaced to remove all of the acid and moisture.

NOTE: NEVER use the compressor to evacuate the system or any part of it.

7.6C REPLACING A COMPRESSOR, NON BURN OUT

Remove the refrigerant from the system. Replace the compressor and liquid line filter/drier. Charge the system to 50 PSIG and check for leaks. Remove the charge and weigh in the refrigerant quantity listed on the nameplate. Operate the system to verify performance.

7.7 REMOTE CONTROLS

The Quest 225 Dehumidifier is controlled by devices mounted on a panel that is remote from the unit. You may or may not have the devices listed below depending on the model of the remote hygostat you purchased.

If the Quest 225 Dehumidifier fails to operate as desired, always check the settings of the controls to ensure that they are correct. Check that the controls are receiving 24VAC from the Quest 225 Dehumidifier. Check the connections between the Quest 225 Dehumidifier, the hygostat, and the field control wiring.

7.7A HUMIDITY CONTROL

The humidity control is an adjustable switch that closes when the relative humidity of the air in which it is located rises to the set point. It opens when the RH drops 4 to 6% below the set point. If the Quest 225 Dehumidifier does not run, try turning the humidity control Down using arrow on control pad. If it then runs, the humidity control is out of calibration or the RH is below setpoint.

7.8 DEFROST SYSTEM

The Quest 225 Dehumidifier is equipped with an automatic defrost mechanism. If the Quest 225 Dehumidifier operates in conditions that develop frost on the evaporator, it will sense the frost build-up and automatically defrost the evaporator. The Quest 225 Dehumidifier may not appear to be operating correctly during the defrost sequence, but once the defrost sequence is completed, the Quest 225 Dehumidifier will resume dehumidifying.

The evaporator temperature sensor is installed into the center of the evaporator coil. It will automatically shut the compressor off if the temperature drops due to excessive frost formation on the evaporator coil. The impeller fan will continue to run, causing air to flow through the evaporator coil and melt the ice. When the ice has melted, the evaporator temperature will rise, and the control will restart the compressor.

7.9 CONDENSATE PUMP KIT

An optional condensate pump kit is available from the factory for use with the Quest 225 Dehumidifier. Condensate is automatically pumped to a remote location when the water level in the pump's reservoir rises to close the float switch.

The pump also contains a safety float switch. The white leads from this switch extend from beneath the pump cover. These leads should be extended to the FLOAT terminals on the terminal block and the factory float jumper removed. If the pump fails, the safety switch opens causing the compressor to stop and water production to cease before the reservoir overflows. E4 will be displayed on the control panel. The Quest 225 Dehumidifier will not dehumidify until this switch closes.

A warranty certificate has been enclosed with this unit; read it before any repair is initiated. If a warranty repair is required, call the factory first at 1-877-420-1330 for warranty claim authorization and technical assistance.

8. QUEST 225 ERROR CODES

#	NAME	MACHINE DISPLAY	POSSIBLE CAUSE(S)	CRITICAL?
1	RH SENSOR ERROR	Error code "E1"	Broken sensor, unplugged sensor	No Displays E1, but keeps running.
2	NOT USED	-	-	-
3	OUT OF REFRIGERANT	Error code "E3" • compressor off • fan off	Refrigeration leak	Yes
4	FLOAT SWITCH TRIPPED	Error code "E4" • compressor off • fan off	Tripped float switch, Loose wire	Yes
5	EVAPORATOR SENSOR ERROR	Error code "E5" • dehu mode: 15 minutes • defrost mode: 30 minutes	Broken sensor, Loose connection	No
6	TEMPERATURE TOO HIGH	Error code "E6" • compressor off • fan off	Temperature too high, Broken sensor	Yes
7	TEMPERATURE TOO LOW	Error code "E7" • compressor off • fan off	Temperature too low, Broken sensor	Yes
8	COMM ERROR	Error code "E8" Power board continues to run unit	RJ12 cable / connection issue	No. Displays E8, but keeps running.
9	HIGH PRESSURE CUT-OUT	Error code "E9" Power board will be in system protection mode	Loose connection, High pressure in refrigeration system	Yes. Display E9 on all state that the seven segment display is illuminated.

WIRING DIAGRAM OF THE QUEST 225 DEHUMIDIFIER

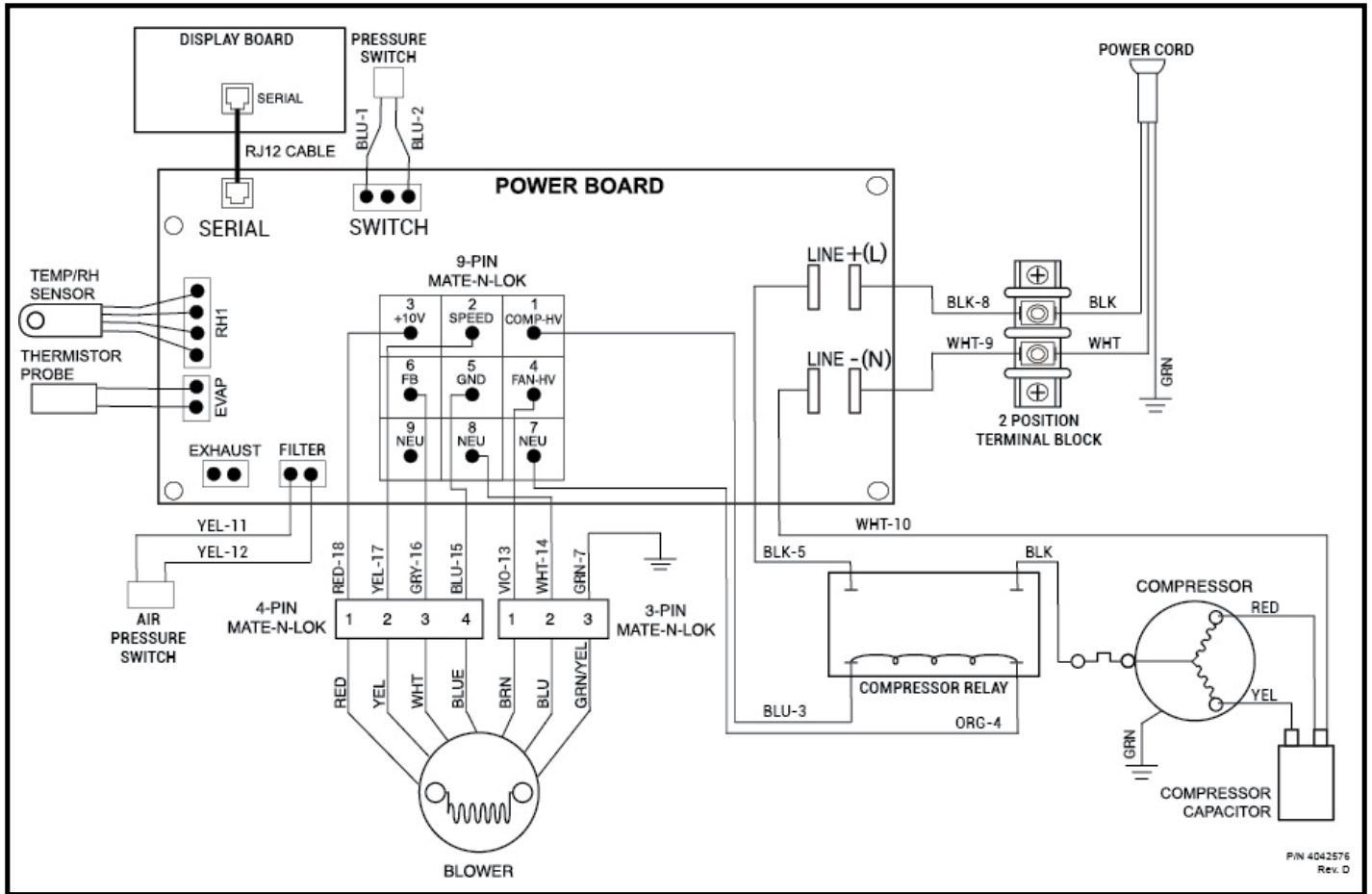

SERVICE PARTS LIST FOR QUEST 225

Item	Part No	Qty	Description	Item	Part No	Qty	Description
1	4042787	1	MERV-13 Air Filter 2x18x18"	9	4042467	1	Relay, SPST 220V, 25A
2	4026221	4	Leveling Foot	10	4034716-03	1	Thermistor Probe*
3	4042468	1	Filter/Drier	11	4042061	1	Temp RH Sensor
4	4042849	1	Compressor	12	4043292	1	High Pressure Switch
5	4042800	1	Coil Cassette Assembly	13	4042903	1	Pressure Diff Switch
6	4039988	1	Compressor Overload	14	4041909	1	Digital Display Board
7	4042845	1	Impeller Assembly*	15	4042291	1	Control Board
8	4035949-10	1	Capacitor, Run, 45 MFD	16	4042009	1	Cover, UI, 24VAC

* Not pictured

OPTIONAL PARTS LIST

Part No	Qty	Description	Part No	Qty	Description
4022220	1	Pump Kit (110-120V)	4028531	1	DEH 3000R Control, Remote
4043235	1	Supply & Return Duct Kit			

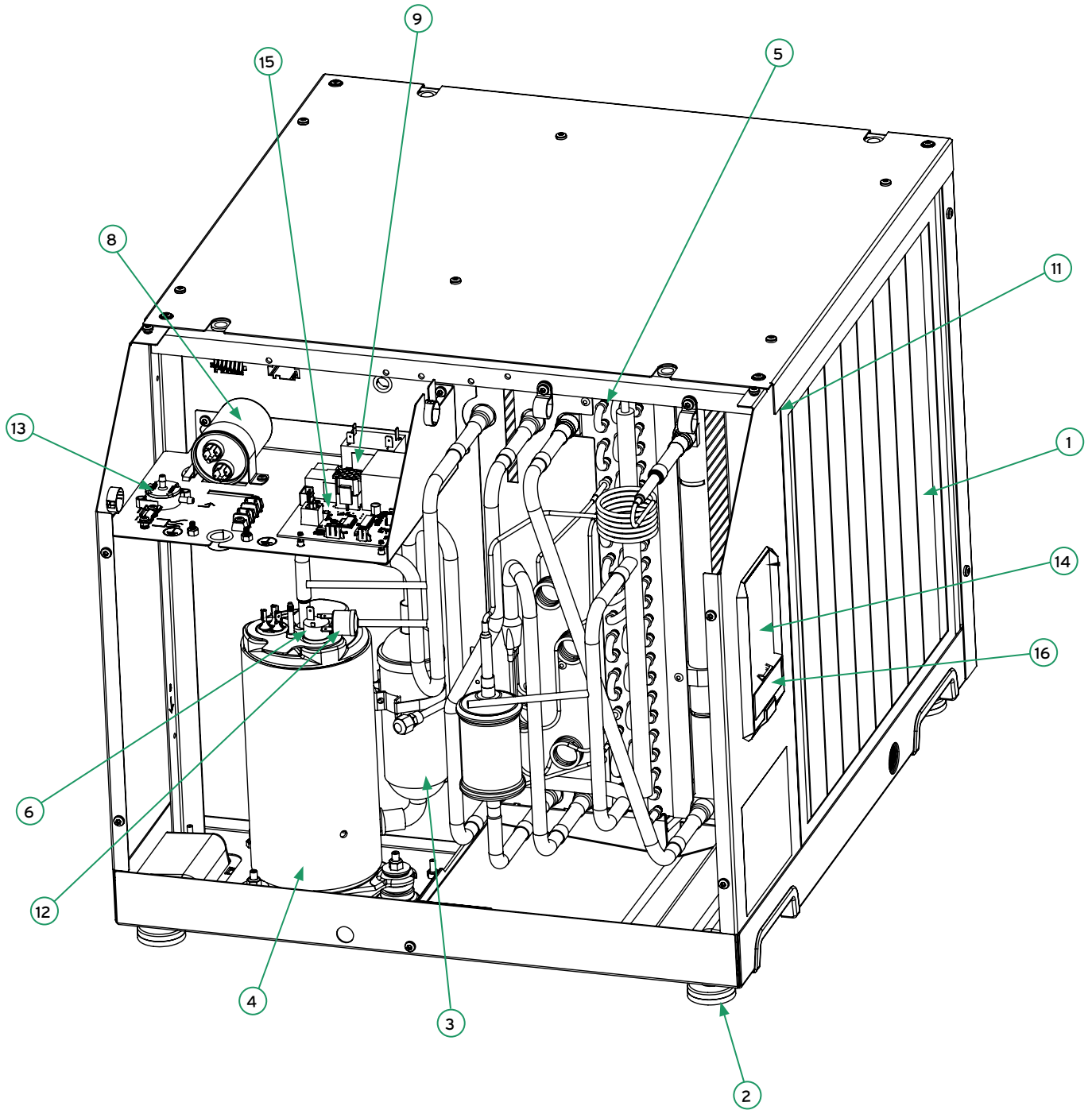

DO NOT DISCARD

IMPORTANT WARRANTY INFORMATION

QUEST 225 DEHUMIDIFIER LIMITED WARRANTY

WARRANTOR:

Therma-Stor LLC
4201 Lien Rd
Madison, WI 53704
Telephone: 1-800-533-7533

REGISTER YOUR NEW DEHUMIDIFIER
using the serial number and part number at
www.thermastor.com/registration
or scan code, right.



WHO IS COVERED: This warranty extends only to the original end-user of the Quest 225 dehumidifier, and may not be assigned or transferred.

FIRST YEAR WARRANTY: Therma-Stor LLC warrants that, for one (1) year the Quest 225 dehumidifier will operate free from any defects in materials and workmanship, or Therma-Stor LLC will, at its option, repair or replace the defective part(s), free of any charge.

SECOND THROUGH FIFTH YEAR WARRANTY: Therma-Stor LLC further warrants that for a period of five (5) years, the condenser, evaporator, and compressor of the Quest 225 Dehumidifier dehumidifier will operate free of any defects in material or workmanship, or Therma-Stor LLC, at its option, will repair or replace the defective part(s), provided that all labor and transportation charges for the part(s) shall be borne by the end-user.

END-USER RESPONSIBILITIES: Warranty service must be performed by a Servicer authorized by Therma-Stor LLC. If the end-user is unable to locate or obtain warranty service from an authorized Servicer, he should call Therma-Stor LLC at the above number and ask for the Therma-Stor LLC Service Department, which will then arrange for covered warranty service. Warranty service will be performed during normal working hours.

The End-user must present proof of purchase (lease) upon request, by use of the warranty card or other reasonable and reliable means. The end-user is responsible for normal care. This warranty does not cover any defect, malfunction, etc. resulting from misuse, abuse, lack of normal care, corrosion, freezing, tampering, modification, unauthorized or improper repair or installation, accident, acts of nature or any other cause beyond Therma-Stor LLC's reasonable control.

LIMITATIONS AND EXCLUSIONS: If any Quest 225 Dehumidifier part is repaired or replaced, the new part shall be warranted for only the remainder of the original warranty period applicable thereto (but all warranty periods will be extended by the period of time, if any, that the Quest 225 Dehumidifier is out of service while awaiting covered warranty service).

UPON THE EXPIRATION OF THE WRITTEN WARRANTY APPLICABLE TO THE QUEST DEHUMIDIFIER OR ANY PART THEREOF, ALL OTHER WARRANTIES IMPLIED BY LAW, INCLUDING MERCHANTABILITY AND FITNESS FOR A PARTICULAR PURPOSE, SHALL ALSO EXPIRE. ALL WARRANTIES MADE BY THERMA-STOR LLC ARE SET FORTH HEREIN, AND NO CLAIM MAY BE MADE AGAINST THERMA-STOR LLC BASED ON ANY ORAL WARRANTY. IN NO EVENT SHALL THERMA-STOR LLC, IN CONNECTION WITH THE SALE, INSTALLATION, USE, REPAIR OR REPLACEMENT OF ANY QUEST DEHUMIDIFIER OR PART THEREOF BE LIABLE UNDER ANY LEGAL THEORY FOR ANY SPECIAL, INDIRECT OR CONSEQUENTIAL DAMAGES INCLUDING WITHOUT LIMITATION WATER DAMAGE (THE END-USER SHOULD TAKE PRECAUTIONS AGAINST SAME), LOST PROFITS, DELAY, OR LOSS OF USE OR DAMAGE TO ANY REAL OR PERSONAL PROPERTY.

Some states do not allow limitations on how long an implied warranty lasts, and some do not allow the exclusion or limitation of incidental or consequential damages, so one or both of these limitation may not apply to you.

LEGAL RIGHTS: This warranty gives you specific legal rights, and you may also have other rights which vary from state to state.