

# AS-5

## Alarm Station

The AS-5 Alarm Station is an audible-visual alarm that can be mounted inside or outside the grow rooms or grow facilities. It supports both audible and visible alarms to alert users in the event when the selected parameter goes above/below the preset levels.

The AS-5 can be powered by the DSD-1 Dry Contact Station and connected to the CDA-1. When connected with the CDA-1, the AS-5 can be linked to either AL-1 or AL-2 CO2 sensors channel, or linked to both sensors channels for complete redundancy.

The AS-5 can also directly connect to the Hydro-X Pro (HCS-2), Hydro-X Plus (HCS-3)



## Specifications

### AS-5

#### Input

Connector	DC 5.5*2.1 Male
Rated Voltage	DC12V/24V
Rated Current	60mA

#### Strobe

Color	Red
Flash Frequency	120 FPM

#### Product Dimensions

Size	3.23"/82mm (L) x 3.23"/82mm (W) x 2"/51mm (H)
Product Weight	3.00oz / 85g

#### Working Environments

Temperature	32-122°F (0-50°C)
Humidity	≤90%

#### Package Content

AS-5 Alarm	1pc
------------	-----

#### Package Dimensions

Size	3.35"/85mm (L) x 3.15"/80mm (W) x 3.54"/90mm (H)
Gross Weight	4.73oz / 134g

#### Siren

Sound Pressure Level	85dB
----------------------	------

## Link Up

### AS-5

#### CONNECTION DIAGRAM

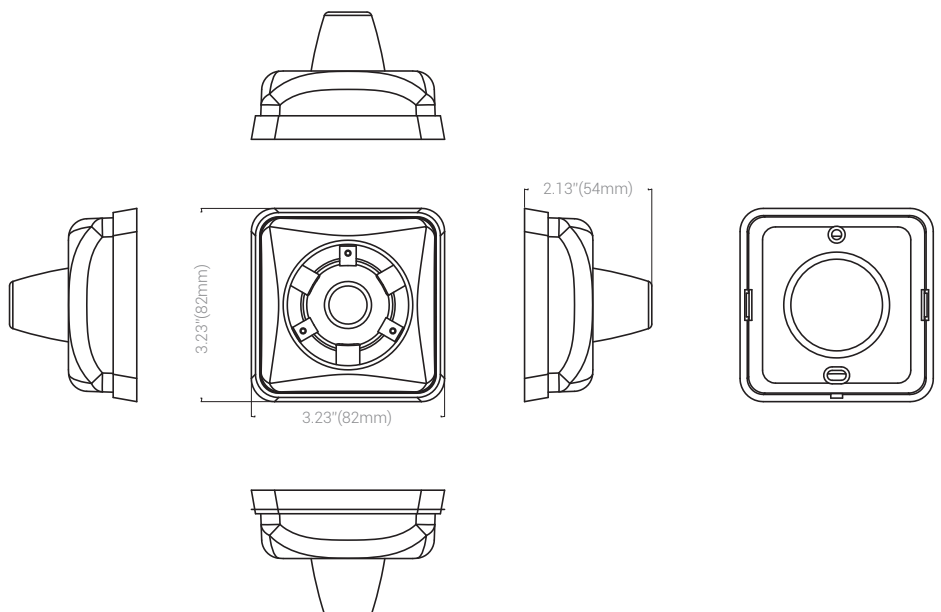
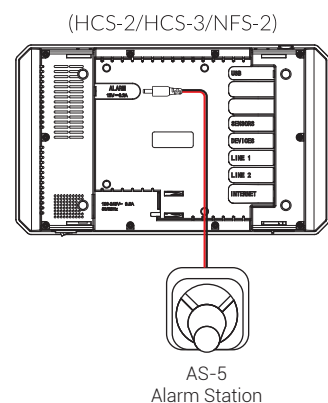

RoHS