

	product	qty
BOK	Galio Insert#2 L=1027 stainless steel LPG	1

DIMENSIONS

	mm	inch		mm	inch		mm	inch
H	260	10 1/4	L	1027	40 7/16	D	230	9 1/16
H1	258.5	10 3/16	L1	944	37 3/16	D1	205	8 1/16
H2	1.5	1/16	L2	41.5	1 5/8			
H3	135	5 5/16	L3	41.5	1 5/8			
H4	107.5	4 1/2						

DESCRIPTIONS

Fuel type - G31/30 (LPG - 37mbar)
Maximal gas rate- ~0,93 kg/h
Heat input (Hi)- ~11,8 kW/h

Battery powered
Black diamond stones finish

Gas supply installation and gas connections must be performed in accordance with local regulations and requirements.

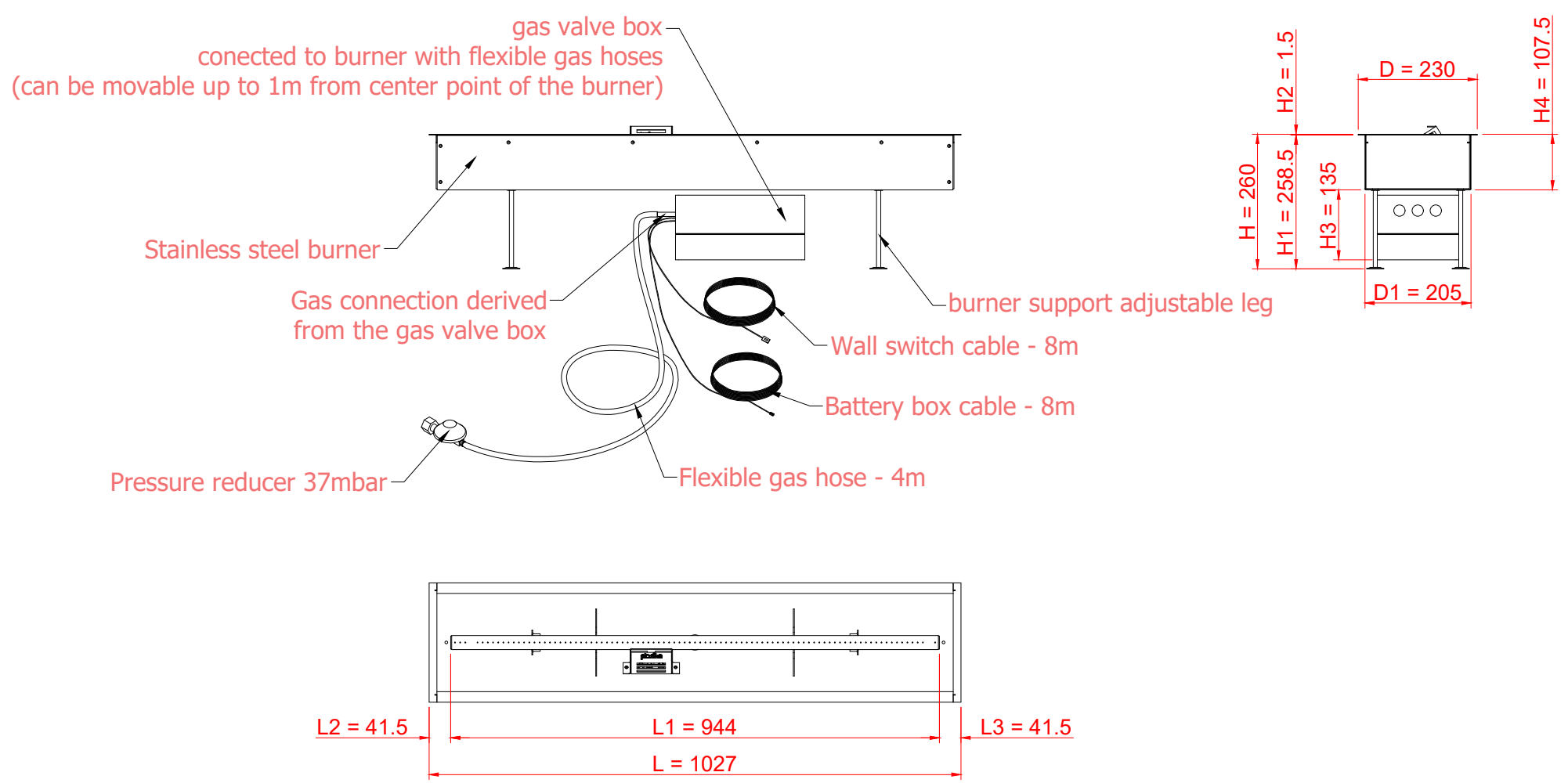

ELEMENTS

<p>Black Diamond Stones</p> <p>G-AC-01 x4</p>	<p>Wallswitch</p> <p>G-AT-30 x1</p>	<p>Battery box - 4xAA type 1</p> <p>G-AT-47 x1</p>	<p>AA battery</p> <p>G-AC-12 x4</p>
---	-------------------------------------	--	-------------------------------------