

	product	qty
BOK	GaLiO Firepit Insert#2 stainless steel LPG	1

DIMENSIONS

	mm	inch		mm	inch		mm	inch
H	250		L	120		D	450	
						D1	350	
						D2	420	

DESCRIPTIONS

Fuel type - G30/31 (LPG - 37mbar)
Maximal gas rate- ~0,4 kg/h
Heat input (Hi)- ~5,1 kW/h

Battery powered
Black diamond stones finish

Gas supply installation and gas connections must be performed in accordance with local regulations and requirements.

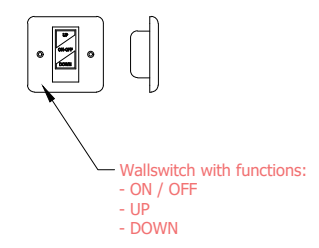
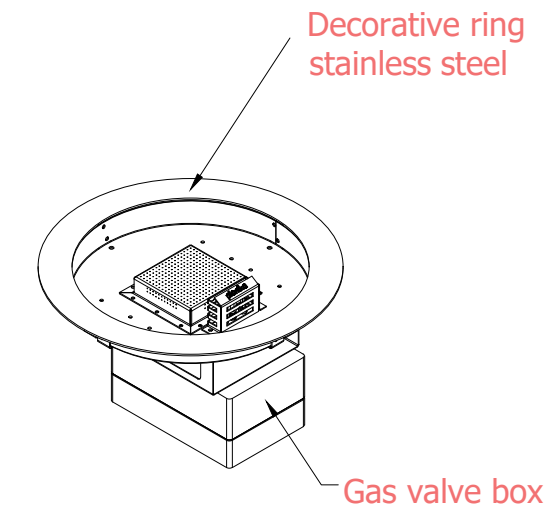
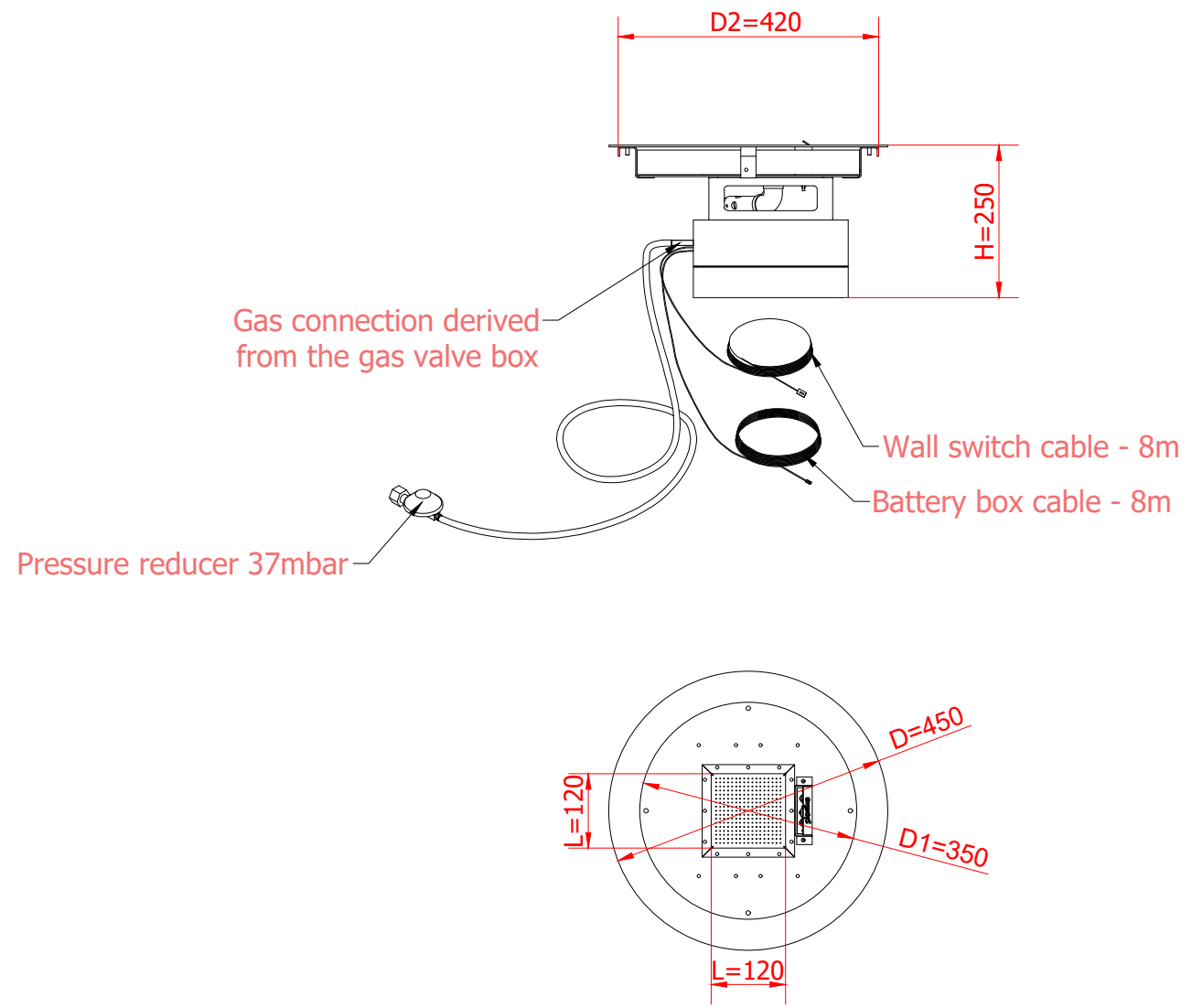

ELEMENTS

Black Diamond Stones G-AC-01 x5	Wallswitch G-AT-30 x1	Battery box - 4xAA type 1 G-AT-47 x1	AA battery G-AC-12 x4						
------------------------------------	--------------------------	---	--------------------------	--	--	--	--	--	--