

A close-up photograph of a light-colored wooden structure, possibly a desk or workbench. The word "VanLab" is engraved in a clean, sans-serif font on the side panel. The wood grain is visible, and there are some dark spots on the surface. The top edge of the structure shows the layered construction of the wood. The background is blurred, showing a window with light coming through.

VanLab

Fitting Guidelines

# Ford Transit 148”

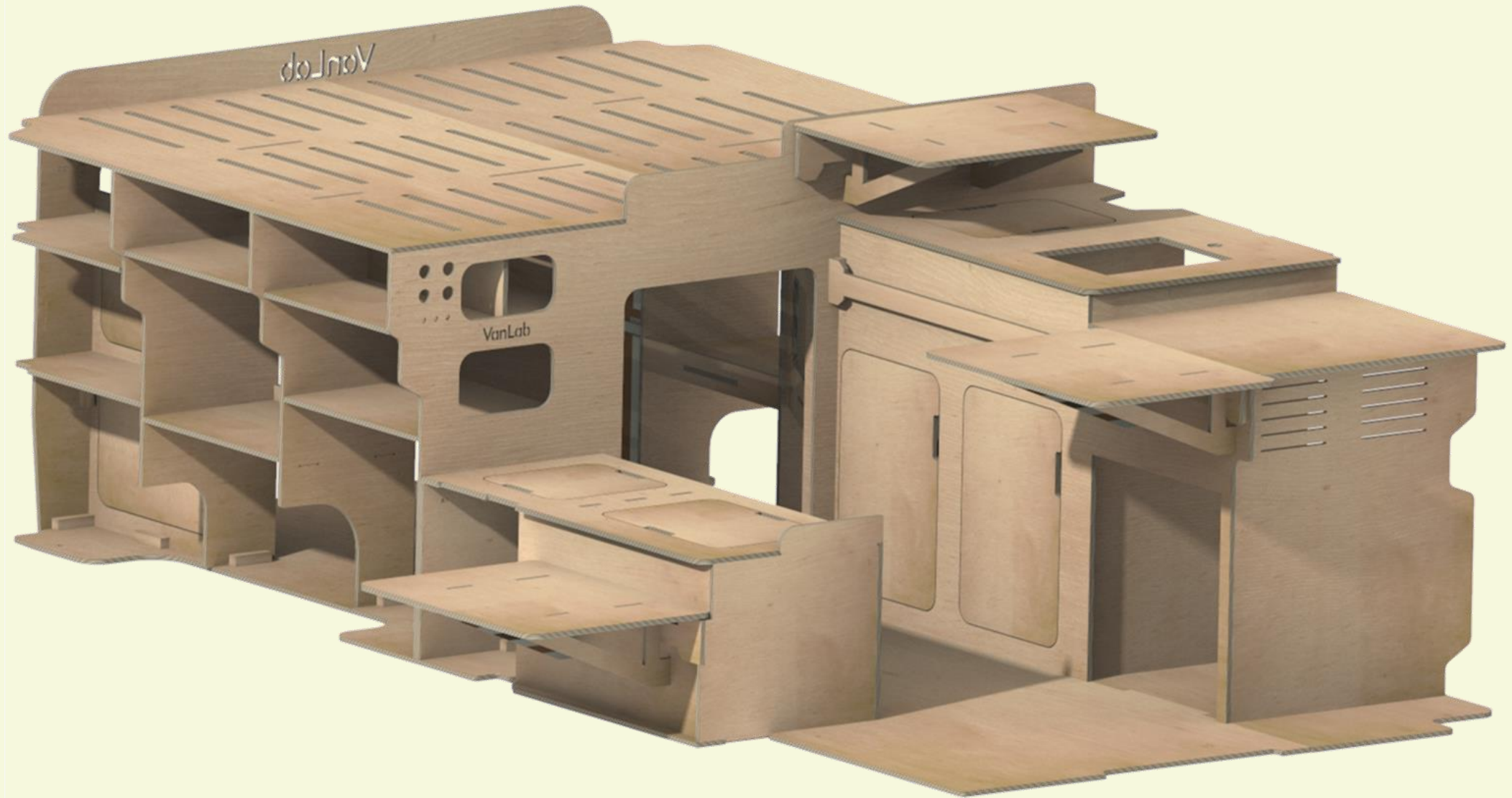

# Parts (Transit 148")

We provide all the parts you will need to put your kit together. We also provide some extras, just in case you lose one.

Tools: You will also find a Square drive screw bit in your kit too. We suggest using a drill or impact driver for the build.

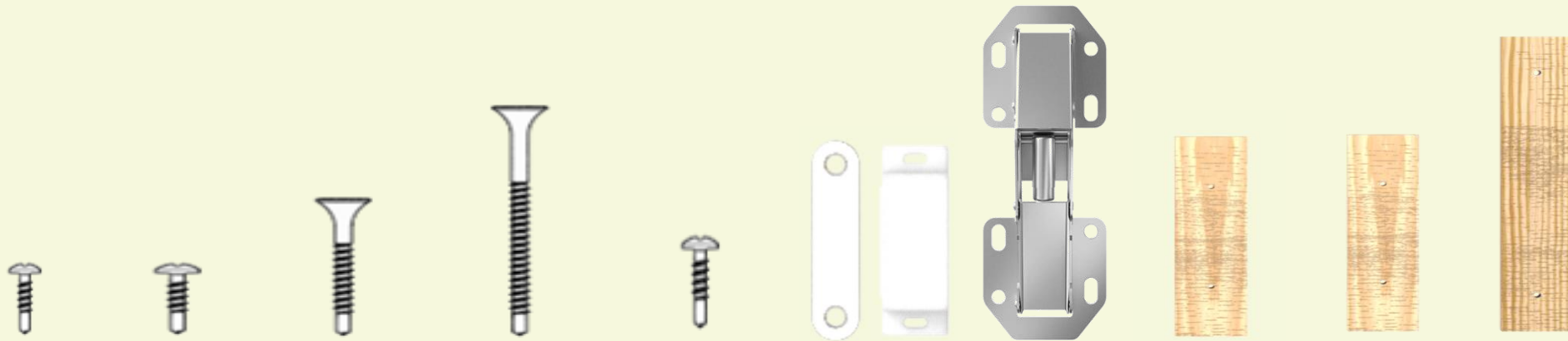

Size	#6 x 5/8"	#6 x 3/8"	#8 x 1 1/4"	#8 x 7/8"	#6 x 7/16"			4" Batten (Plywood)	4" Batten (Pine)	6" Batten (Plywood)
Use	For A12 ONLY	Magnet catch plate	4" & 6" Batten	C27, C28, C29, C30	Hinge	Door Magnets	Door Hinges	Kitchen Rails	General Build	Hatches
Quantity	6	24	540	20	96	6	12	6	160	15

# Contents

## The Rules & Process

## The Sections

1. The Floor
2. Section A
3. Section B
4. Section C
5. The Table

NOTE: These instructions are universal for our Medium sized kit, and there maybe some small variations in the images shown. Please note, the build process and instructions are correct for your build.

# The Rules & Process

**IMPORTANT!**

You **MUST** understand the Rules & Process before you begin, as they need to be followed to assemble your kit correctly.

Refer back to them regularly during the build process.

# The Rules

## Batten

The 4" Batten has 2 holes on one side and 1 hole on the another

- Always screw the 2 first (A)
- Then the 3rd (B)

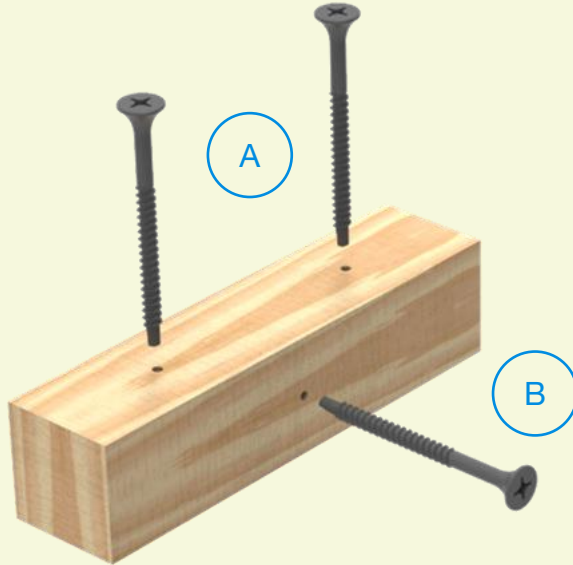

The 6" batten have 2 holes in the same orientation. They are used for the Section B hatches only

— The 8" batten have 3 holes. They are used for the rails (see Page 19 & 24) only

## Panel Symbols

The panels have symbols to show you the location of the batten and how to fix the part. You have 3 symbols: The Rectangle, The Crosses and

The Rectangle

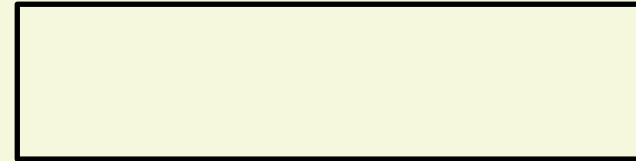

Place the batten over the box on the face you are looking at.  
Screw into panel from the side you're looking at and screw through batten first and into the panel

The Crosses

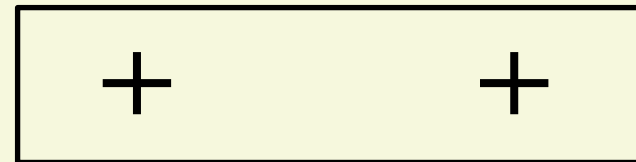

Place the batten over the box, on the face you are looking at.  
BUT, screw from the opposite side

The Line

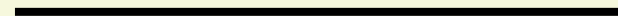

Place the batten on the opposite face of the panel.  
Screw from the side you're looking at.  
In this case, screw through the panel first and into the batten

## Let's try an example:

Find Panel C2, as C2 has both 'The Rectangle' and 'The Line' symbol

- The battens will be screwed in as pictured.
- You can see that the rectangle means the battens are on the front face of the panel
- The line denotes that the batten is on the back side of the panel.
- Both are screwed in from the front face of the panel

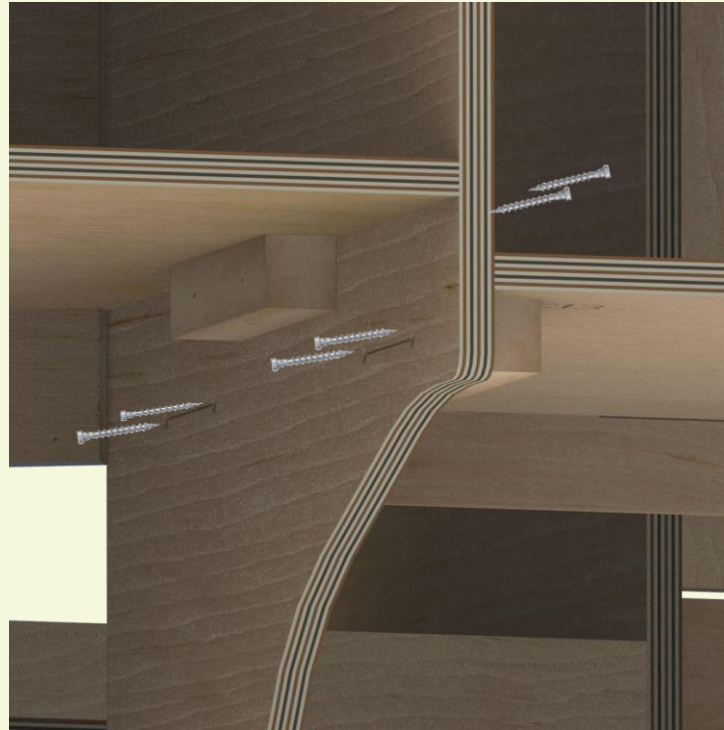

## Key Tip!

For anytime you see 'The Rectangle'. Partially drive the screws into the battens separately before fastening to the panel for easier pilot hole location.

*!Be careful to line up the pilot holes with the screw as the batten may split if they are incorrectly aligned.  
Don't worry if you do, as we have provided plenty of spares!*



## Key Tip!

For anytime you see 'The Line'. Partially drive the screws through the panel separately before fastening to the batten. Same approach, but the opposite order.

# The Process

1 Adding panels to the floor

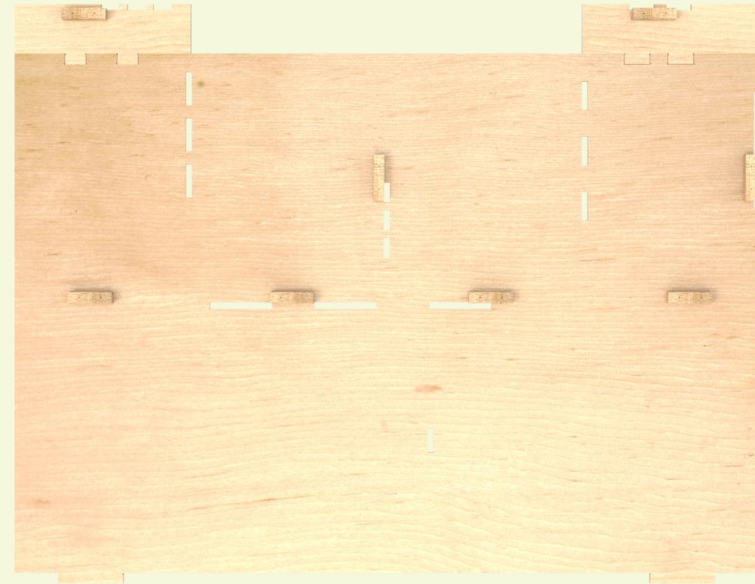

2 Batten on panel



3 Fit panel

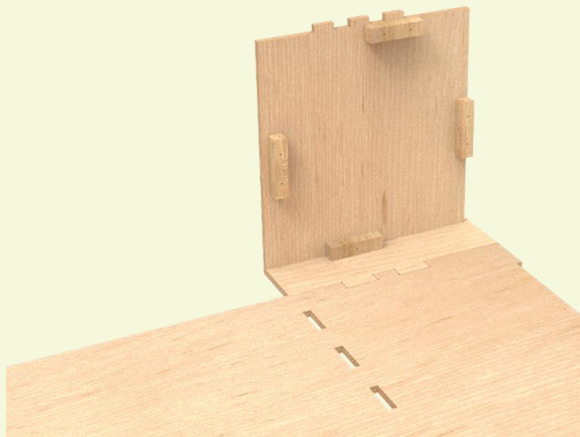

4 Repeat

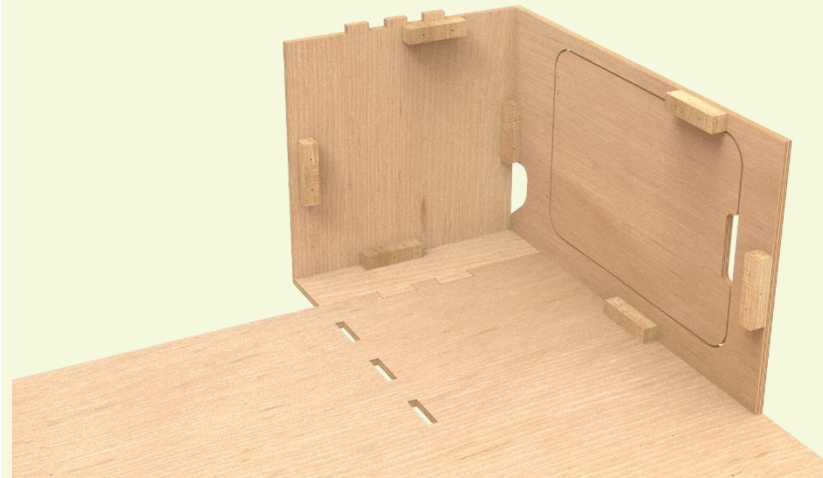

## Key Tip!

Separate all the parts.

Stack the parts from section A, section B and section C in separate places before building.

You'll notice the panels are engraved with a letter and a number. Section A consists of parts A1, A2, A3.....  
Section B consists of parts B1, B2, B3 etc.



# The Sections

Section C

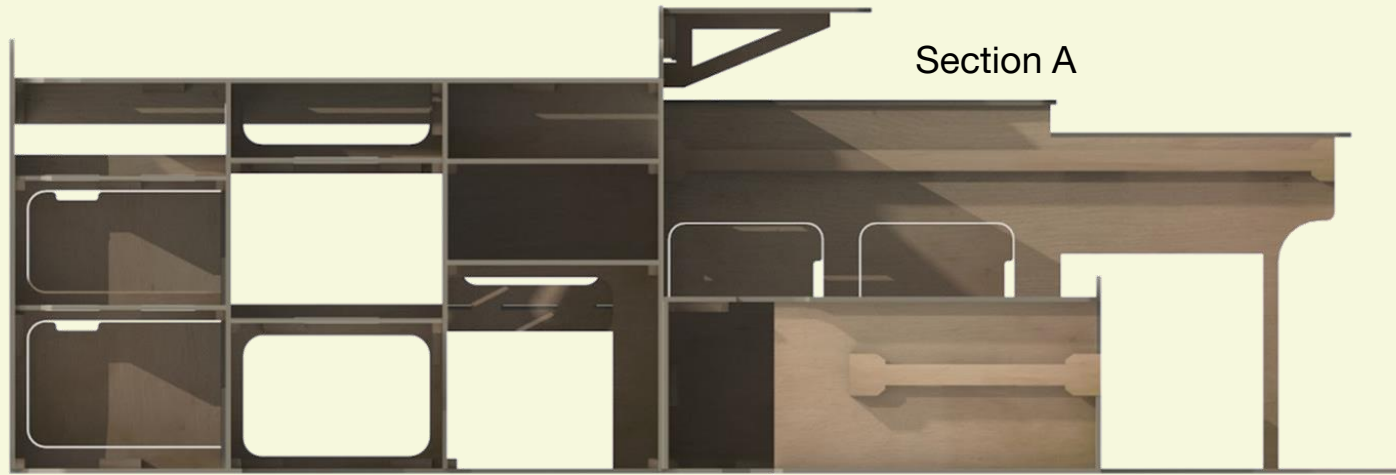

Section A

Section B

Side View

Plan View

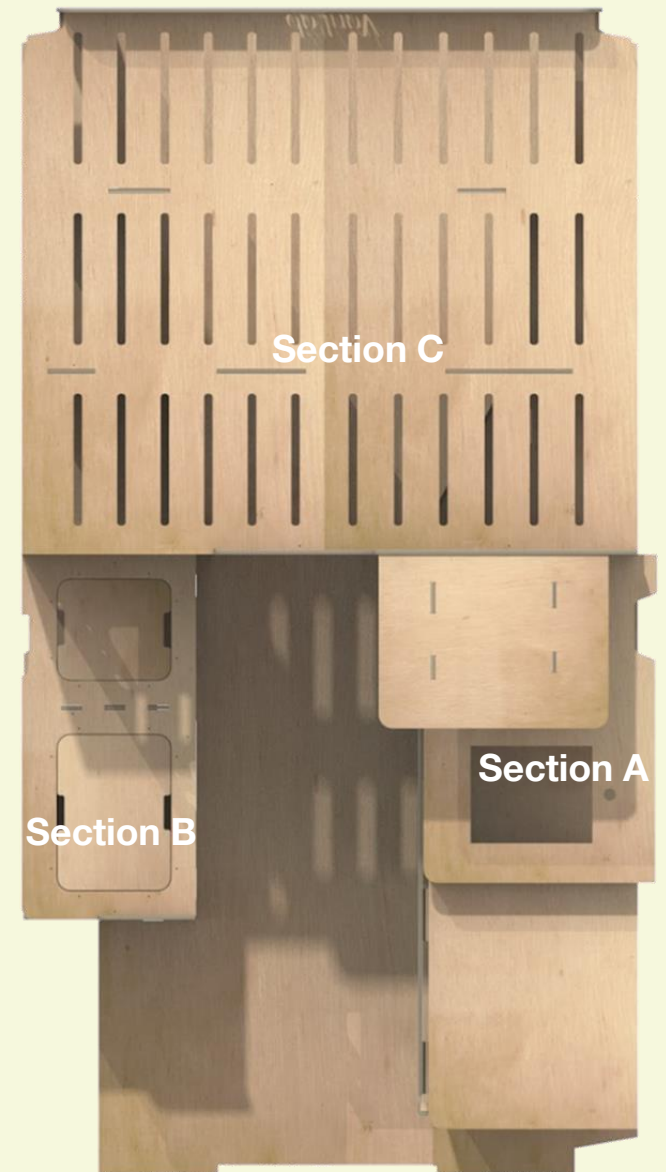

Section C

Section A

Section B

You'll notice the panels are engraved with a letter and a number.

Section A consists of parts engraved A1, A2, A3... etc.

Section B consists of parts engraved B1, B2, B3... etc.

Section C consists of parts engraved C1, C2, C3... etc.

# Lets get started!...

# 1.The Floor



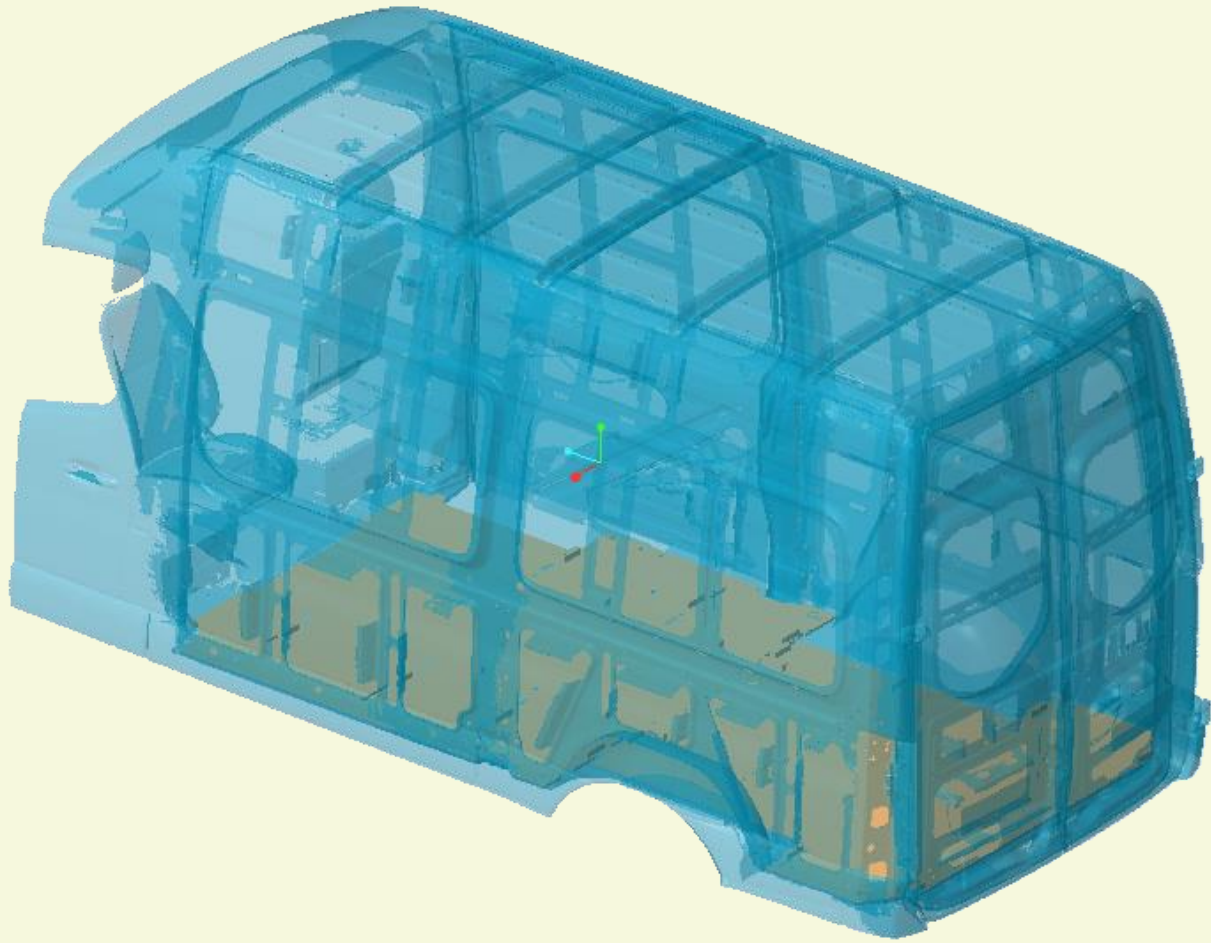

# The Process

# 1

Lay the floor pieces down **OUTSIDE** the Van first with the engravings facing up

There are 5 floor sections.

1. Front left
2. Front middle
3. Front right
4. Middle section
5. Rear section

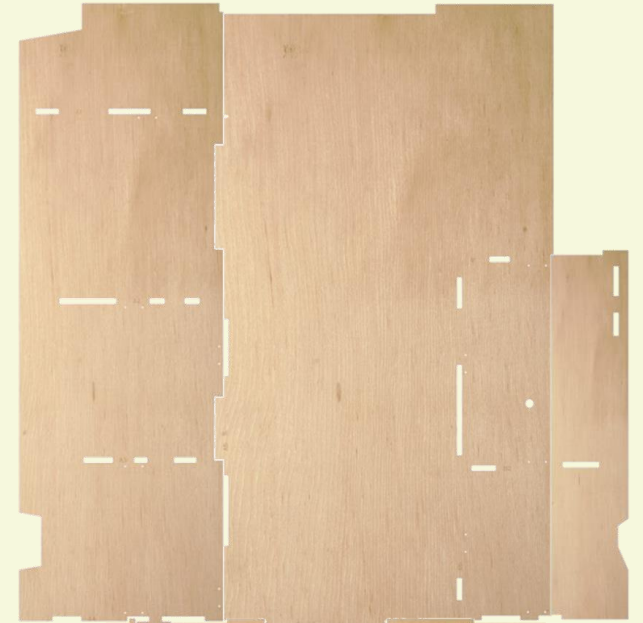
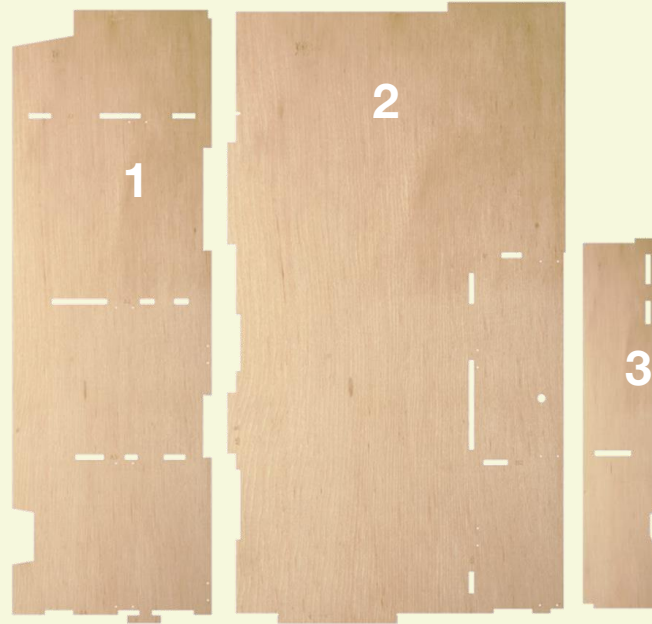

# 2

## Screw the batten to the floor

- You now need to screw each of the 28 batten to the top face of the flooring sections. You can distinguish what the top face of the floor is by the engraving. The underneath face will be clear of any engravings.
- The batten locations are denoted by 2 'Crosses' in a rectangle (*Reminder: see Page 6*)
- To do this, place the batten down facing you BUT screw from the other side of the flooring so the screw goes through the flooring FIRST and then into the batten.
- Now the floor is in place outside the van you can screw the batten to each part more easily before carrying them inside the van and slotting in place like a jigsaw.

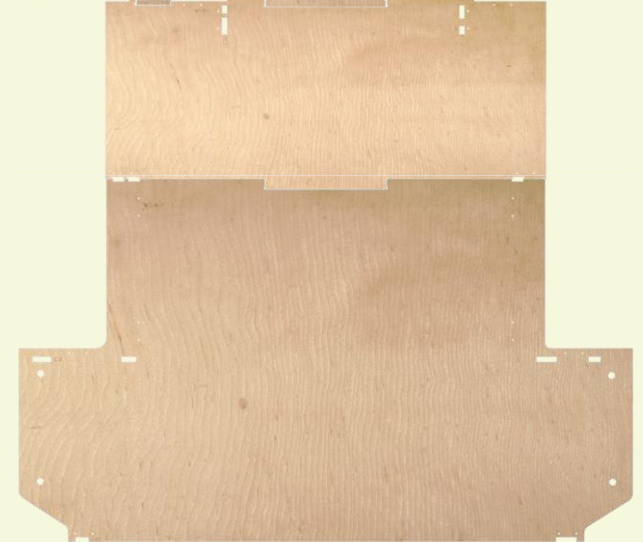
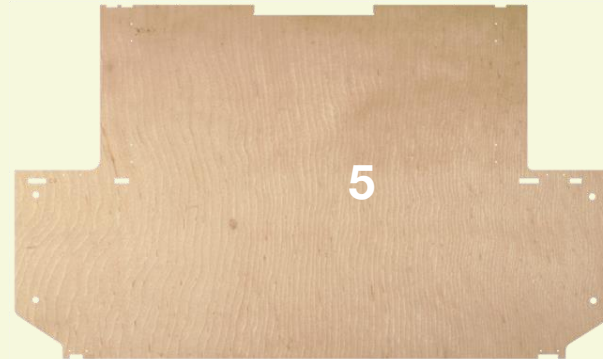

# The Process

## 2

### Screw the batten to the floor

- You now need to screw each of the 28 batten to the top face of the flooring sections. You can distinguish what the top face of the floor is by the engraving. The underneath face will be clear of any engravings.
- The batten locations are denoted by 2 'Crosses' in a rectangle (*Reminder: see Page 6*)
- To do this, place the batten down on the top face you BUT screw from the bottom face of the flooring so the screw goes through the flooring FIRST and then into the batten.
- Once all the batten is secured to the 5 flooring sections, the flooring can be transferred to the van.
- It is slotted into place as per the previous page. It slots in place like a jigsaw!

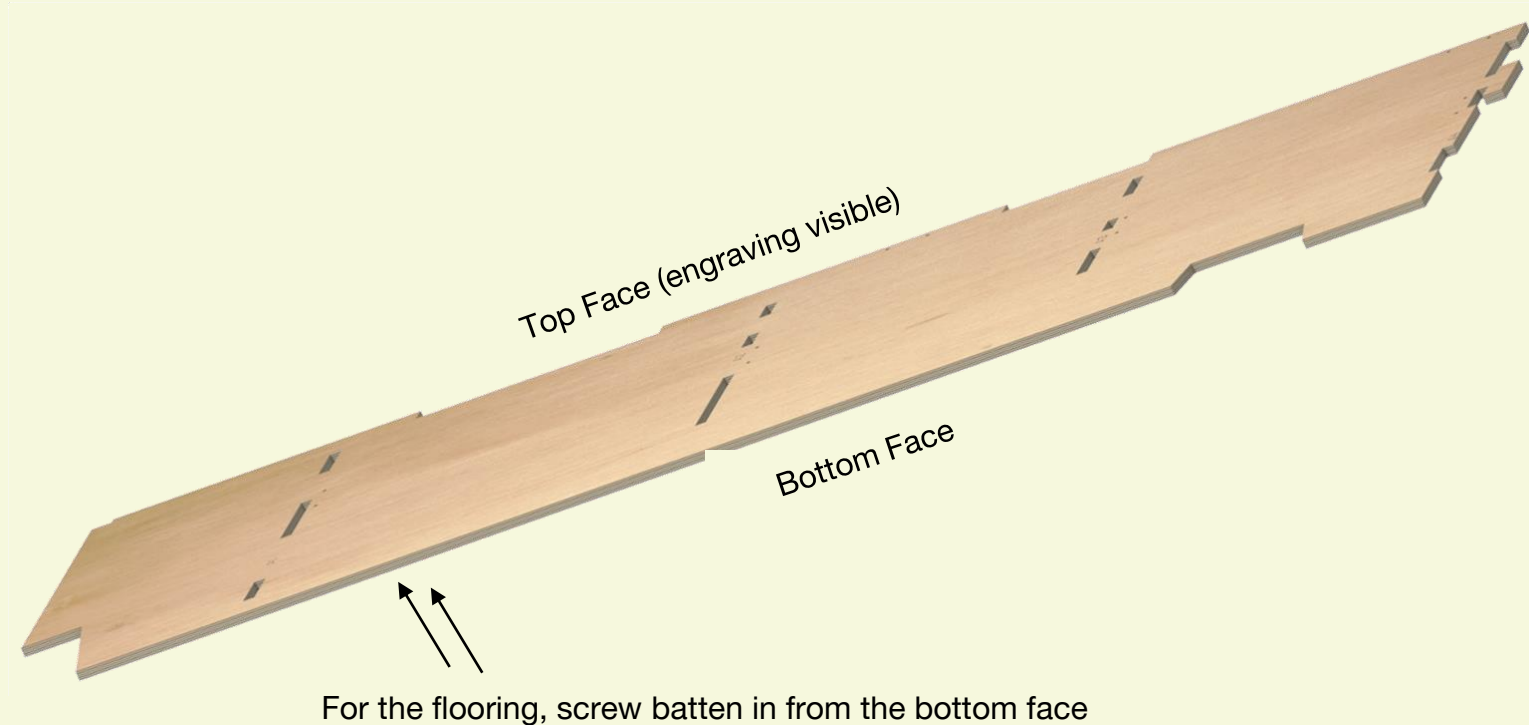

## 2. Section 'A'

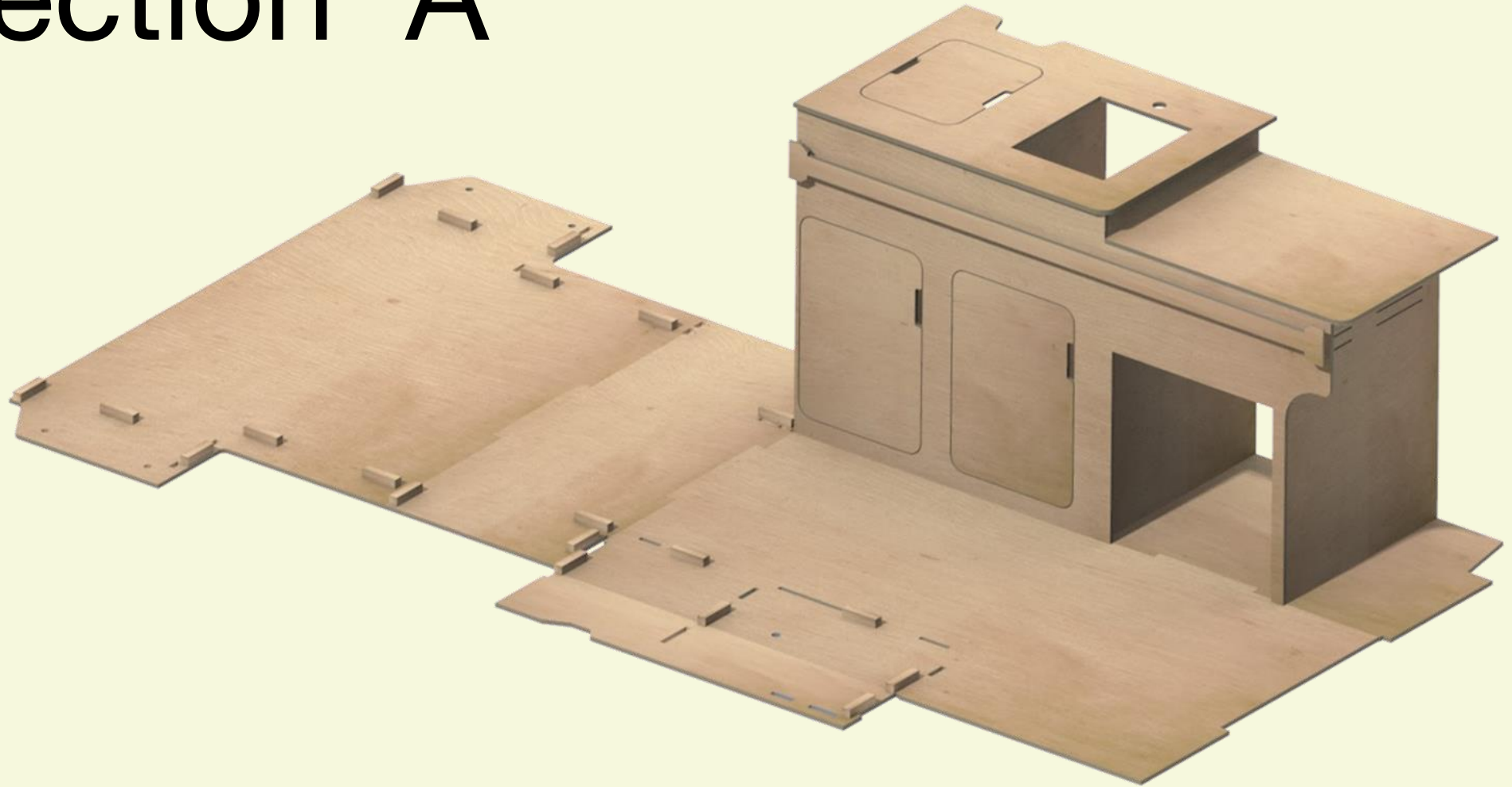

## Section A

# 1

Find panel marked A1

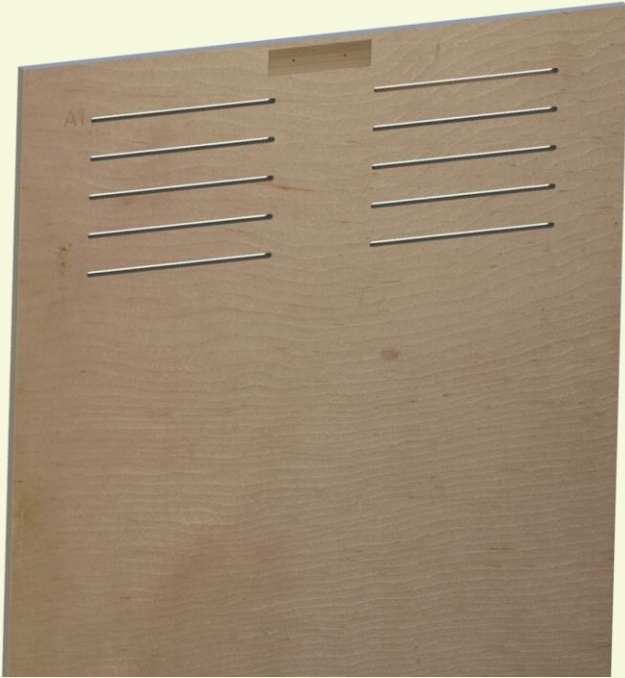

# 3

Fit all batten to panel A1. (refer back to rules if unclear - Screw into panel first then batten)



# 5

Secure A1 in place by fastening any remaining pilot holes.



# 2

Find the #8 x 1 ¼" screws and 4" batten

# 4

Slot A1 in place  
(see marking on floor).



## Section A

# 6

Find panel A2. Screw the batten on to A2 as per the symbol instructions.

Locate the A2 slot on floor and secure in place.

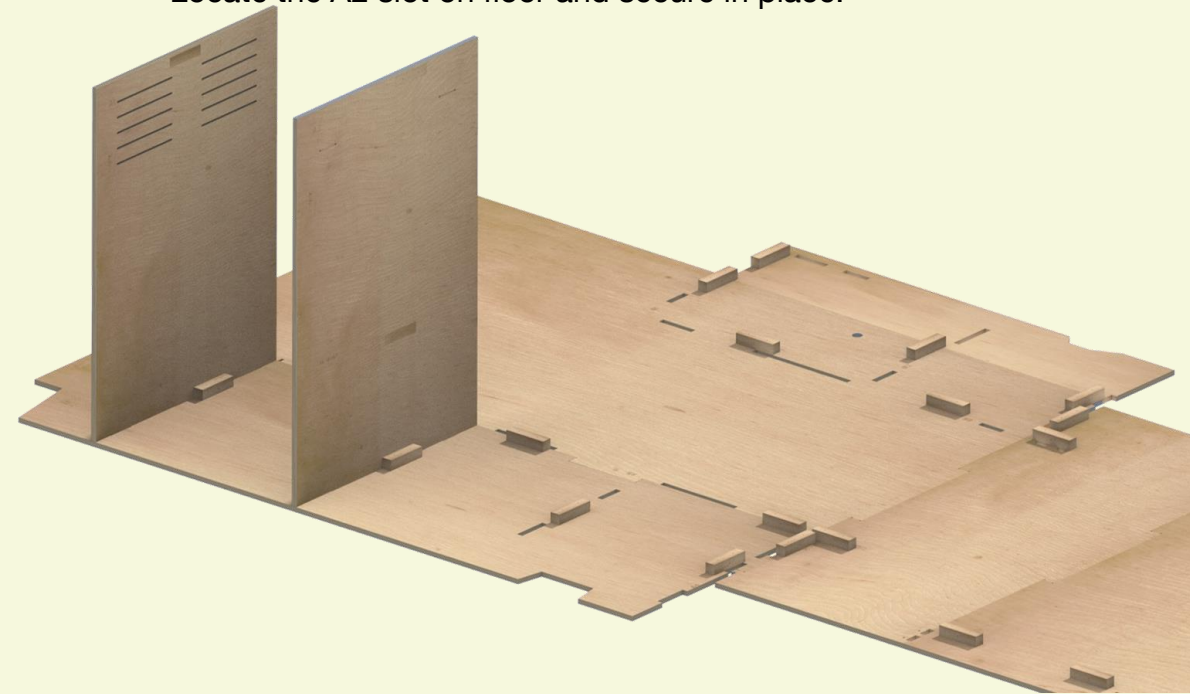

# 8

Repeat for A4.

# 7

Repeat for A3. Remember from our example earlier, A3 has batten on both sides. Note the symbols on this part.

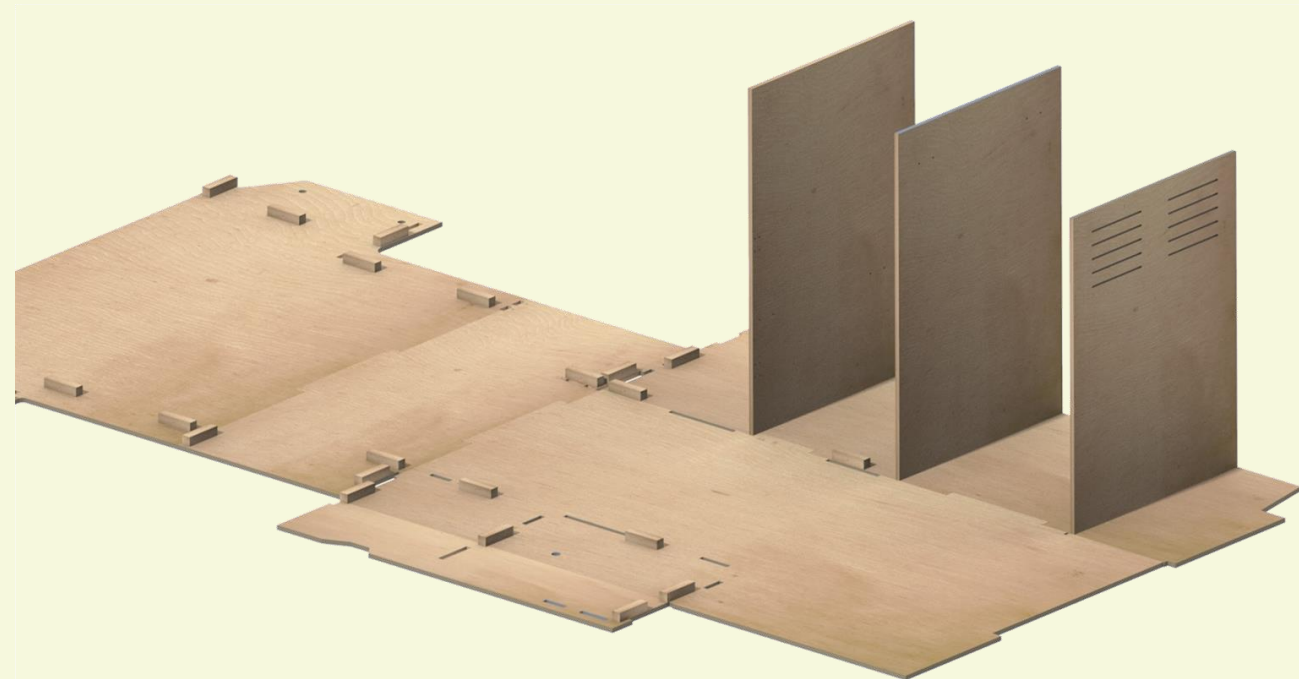

# 9

Find Part A5.

- Screw all 4” batten into place as per the symbols.
- A5 also has 4 horizontal 6” battens. You will use the plywood 6” battens in this part. The etching on A5 with say “PLY” to denote the location as well.
- You will note the location as the line symbol is also 6” long. These 4 batten can be screwed in from the face as shown in the photo
- At this point, the two doors can be secured in place too. Using the supplied small hinges and #6 x 3/8” screws,

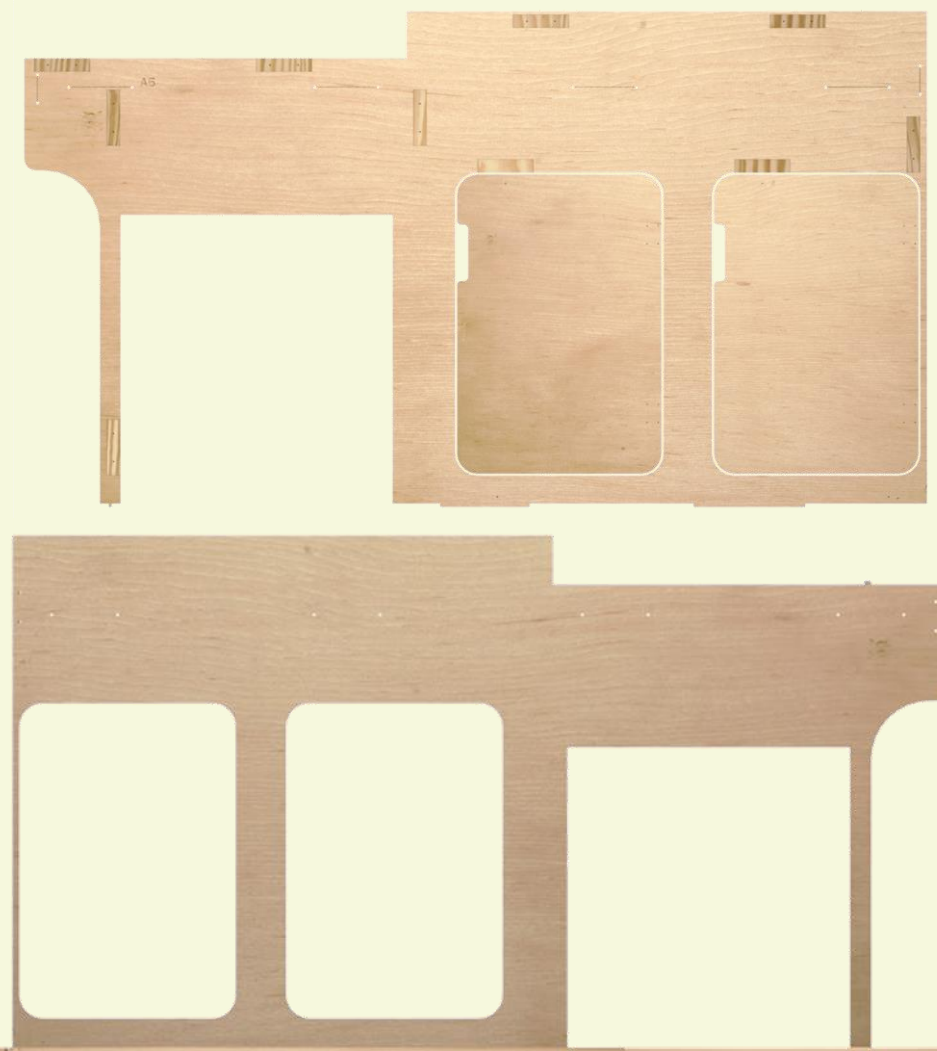

# 9a

Find part A5 doors. You can see 2 sets of 2 holes in a square pattern on each door; these are for the hinges. These hinge holes correspond to the same hole patterns on A3 and A4.

- We advise that you open the hinges up to 180degrees before fitting. This makes it easier to secure in place. NOTE: Check the grain pattern against panel A5 hole to make sure you have the correct door in the correct position.
- Please note the hinges will have a sticker "door this side" This indicates which part of the hinge orientate to the door.

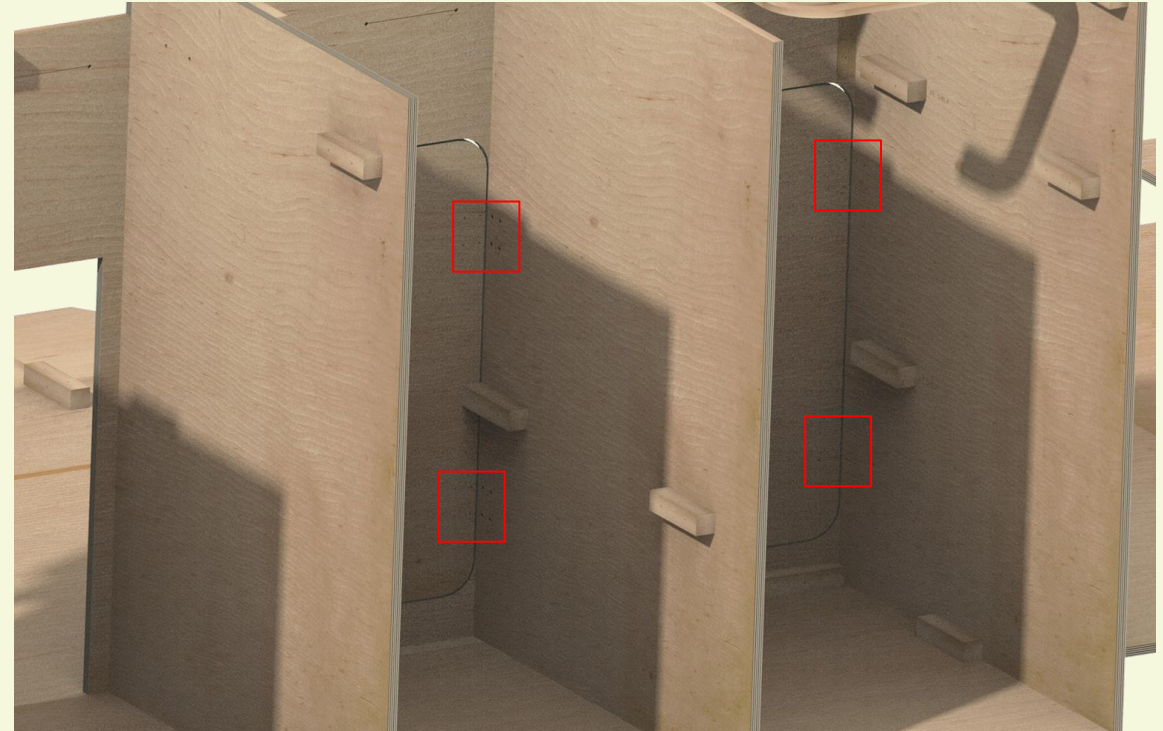

- Using the #6 x 3/8 screws, secure the 2 hinge plates to the uprights of A3 and A4 using the supplied pilot holes. These holes will align with the slots of the hinges, which allows for adjustment. Secure them in place first, and they can be adjusted later when the doors are fitted. They are adjusted by loosening the screw and sliding the door before resecuring the screws. It may take a few attempts to get them just perfect in the open and closed position.
- Holding the door in its open position and using the #6 x 3/8 screws, the open hinge plates can be secured to the door. Once all 4 screws are in place, the door is fitted and you can begin the adjustments. Once happy, you can secure the remaining holes in the hinge plate and move on to the second door.

# 10

The shelves of A6, A7 and A8 can now be fitted.

The Shelves rest on the batten of parts A2, A3 and A4 which you have already installed.

# 11

The shelves (A6, A7, A8) are screwed through the top to secure into place

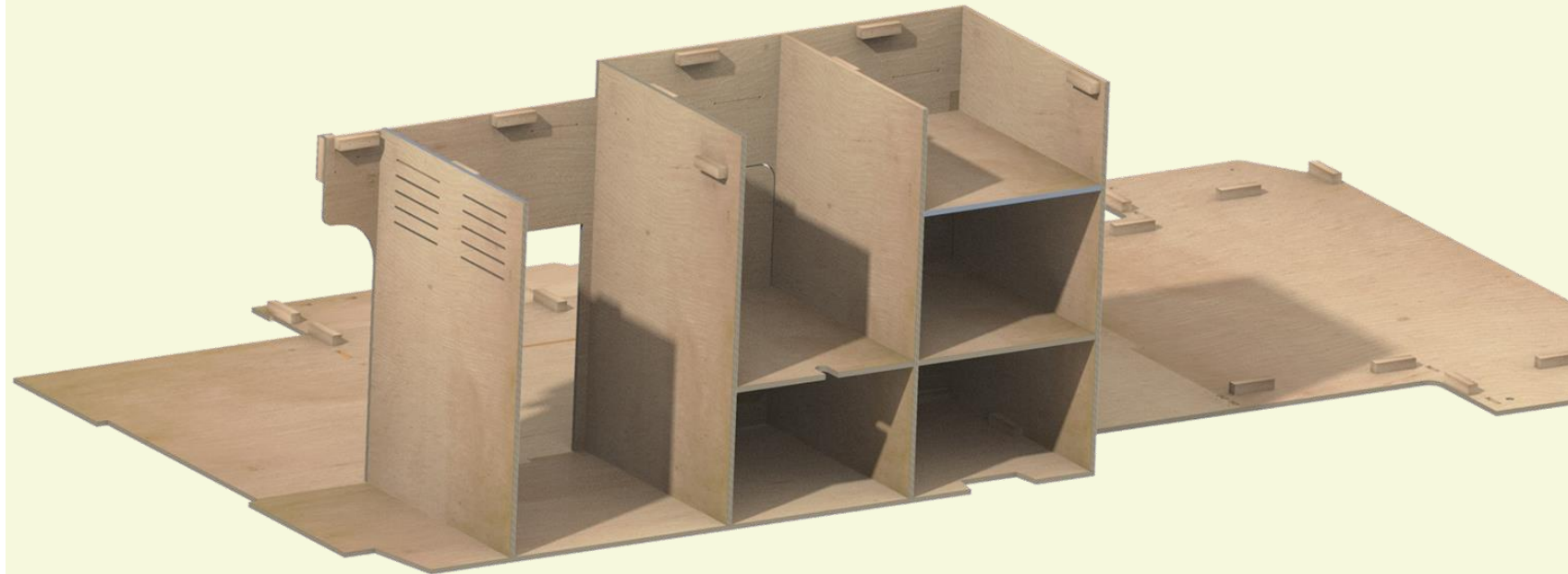

# 12

- You can now fit the rail A9.
- The grooves on rail A9 are used to locate the part on the front face of the kitchen



# 13

The rail is then secured with 4 holes through the front face using the existing pilot holes.

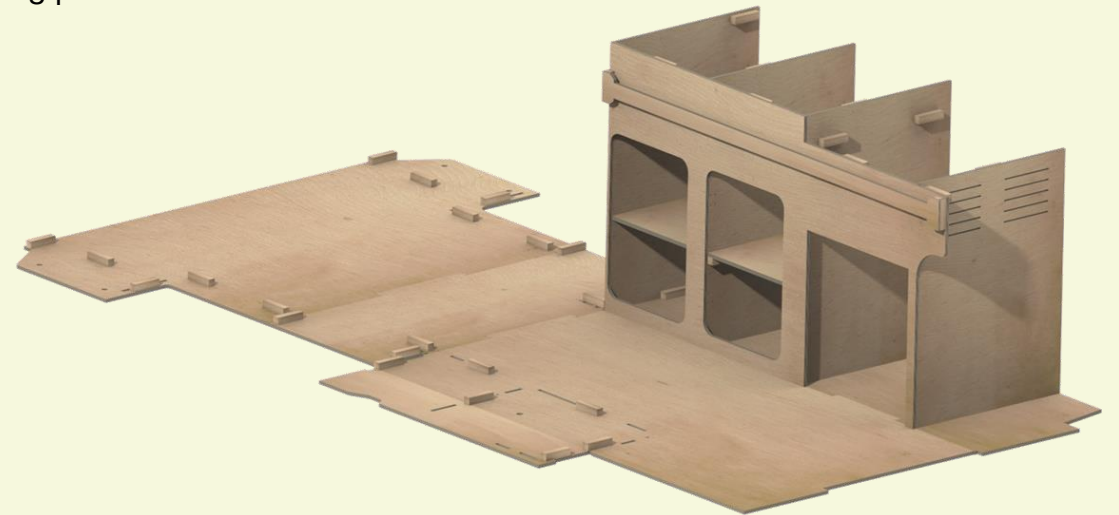
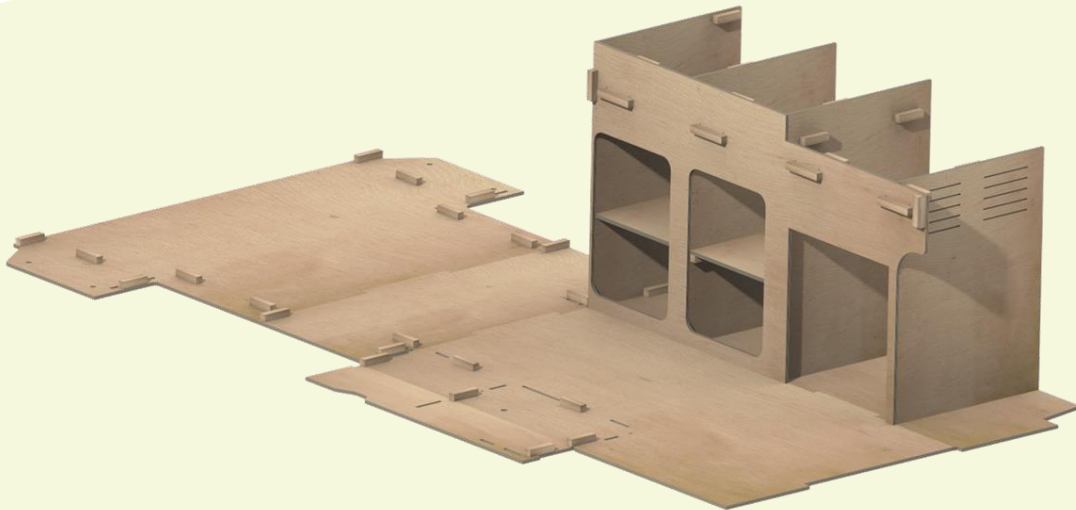

## Section A

# 14

Prior to fitting panel A10, we need to fit the A12 frame. This will support the worktop hatch of A10.

Panel A10 can be seen below

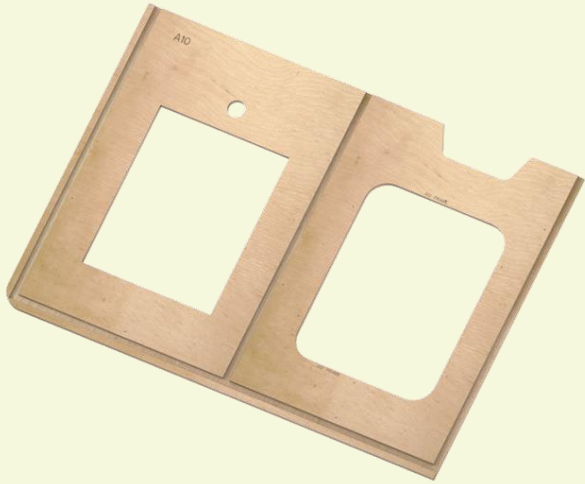

# 15

The A12 frame is in 2 sections

The grooves will slot into the hatch space of part A10.

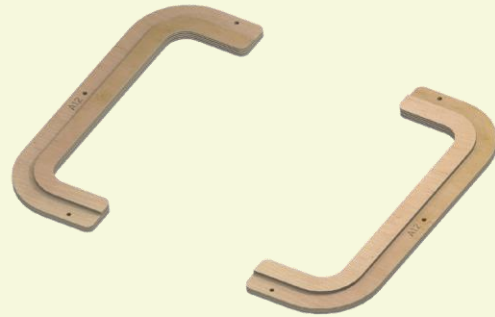

# 16

Secure in place by screwing in from the bottom using the 6 existing pilot holes.

**IMPORTANT:** Use #5 x 5/8" screws, package bag labelled 'Part A12'

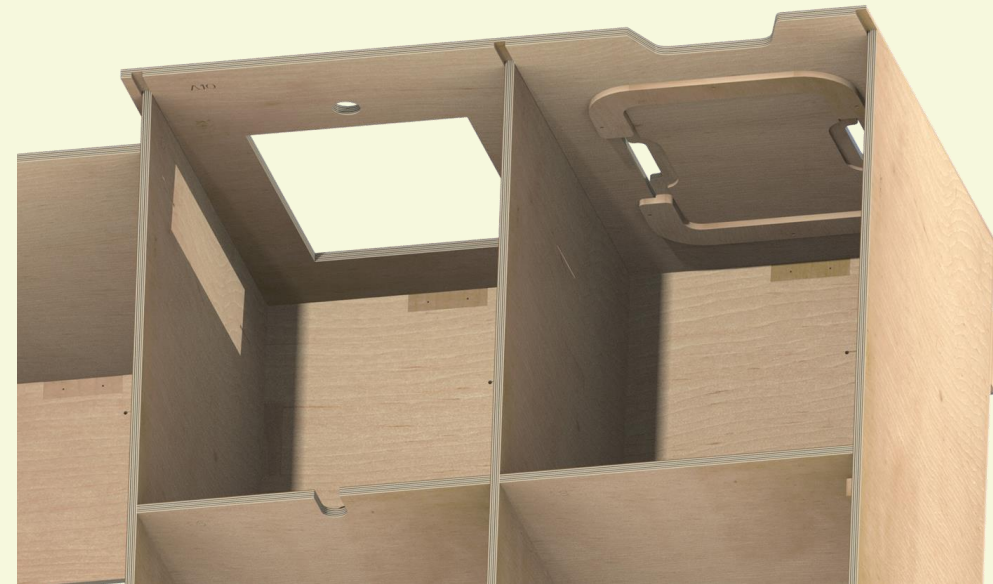

# 17

The part A10, can now be secured in place. The grooves will line up on top of the panels A2, A3 & A4 and slot into place. The worktop is then secured through the batten into the bottom of the benchtop.

Section A

18

A11 can now be fitted at the front of the kitchen unit using the same technique as A10

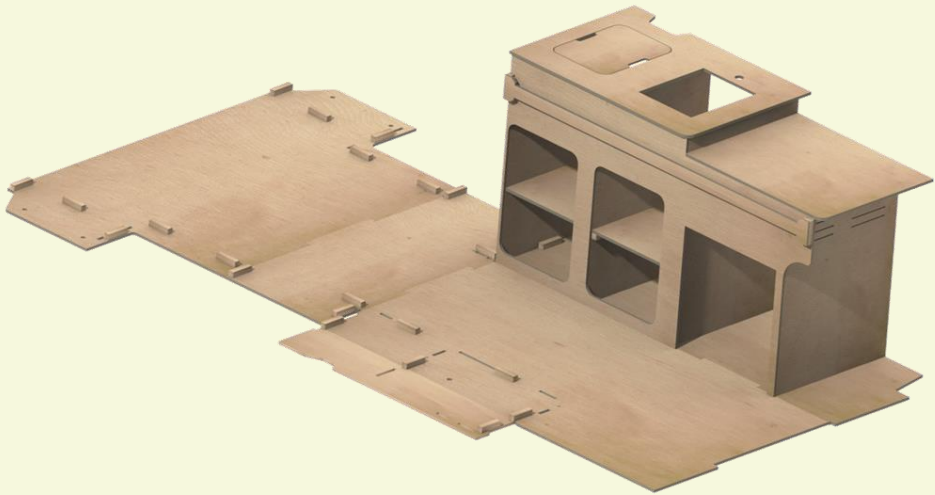

19

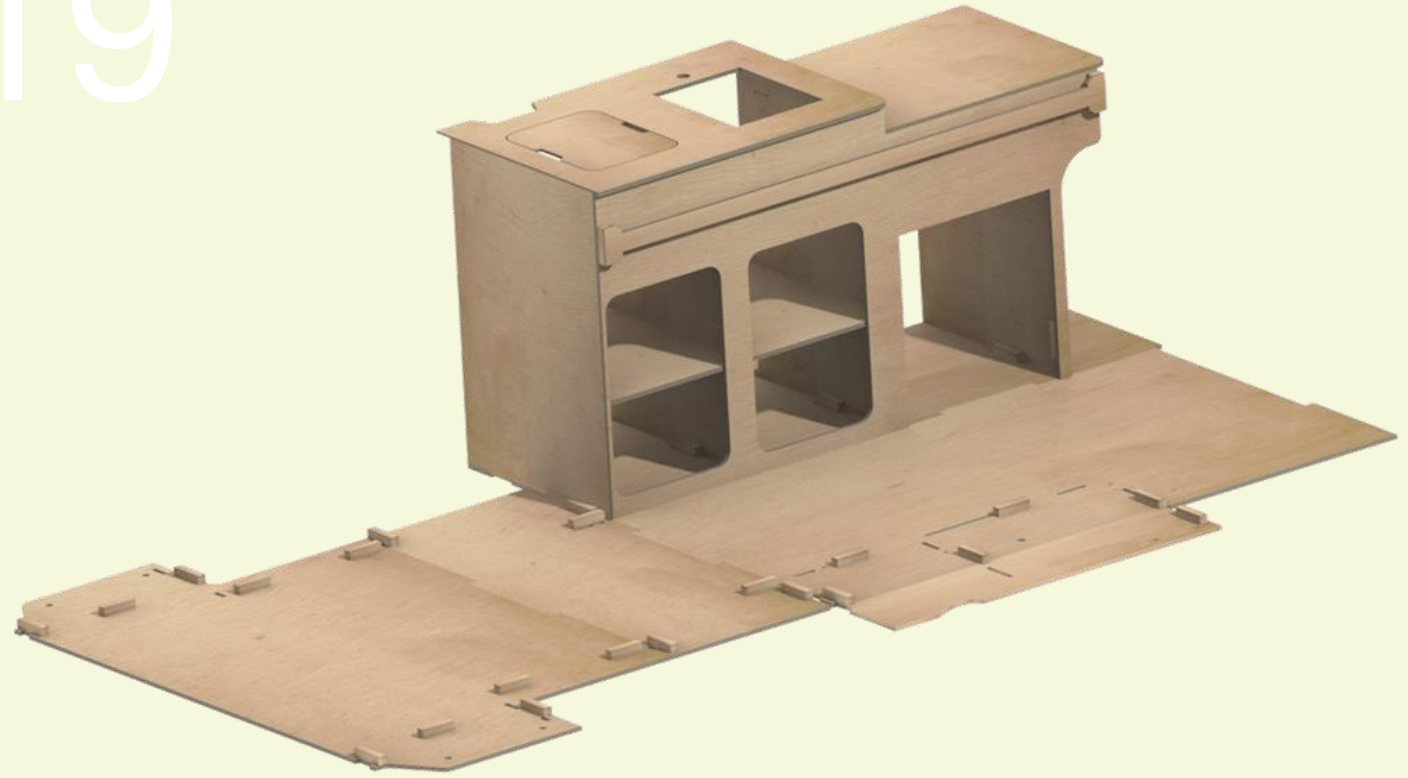

Section A is complete

# 3. Section 'B'





## Section B

# 1

Find Panel B1

Fit all batten to panel B1.

Note, symbols indicate direction of screw.

Slot B1 in place

(see marking on floor).

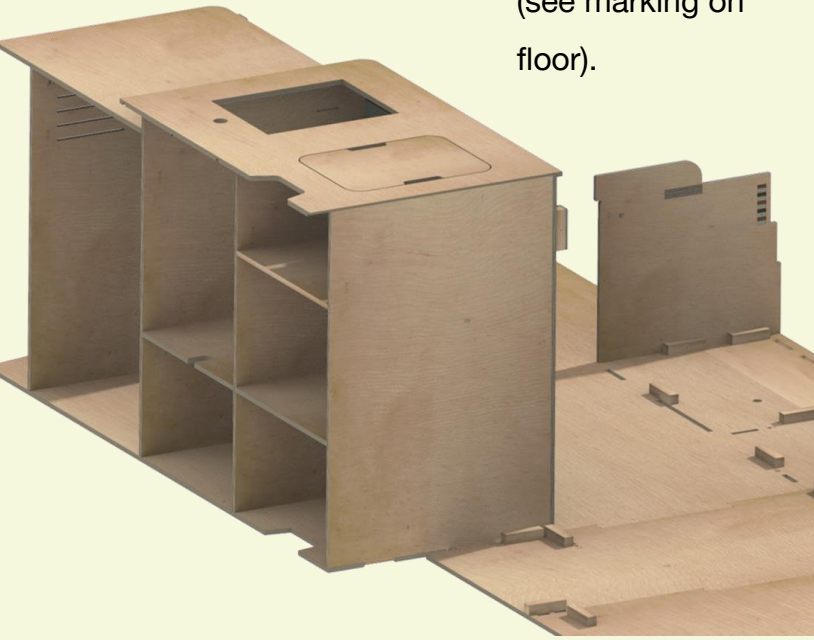

# 2

Secure B1 in place by screwing any remaining pilot holes.

# 3

Fit all batten to panel B2.

Reminder, symbols indicate direction of screw.

# 4

Slot B2 in place  
(see marking on floor).

# 5

Secure B2 in place by fastening any remaining pilot holes.

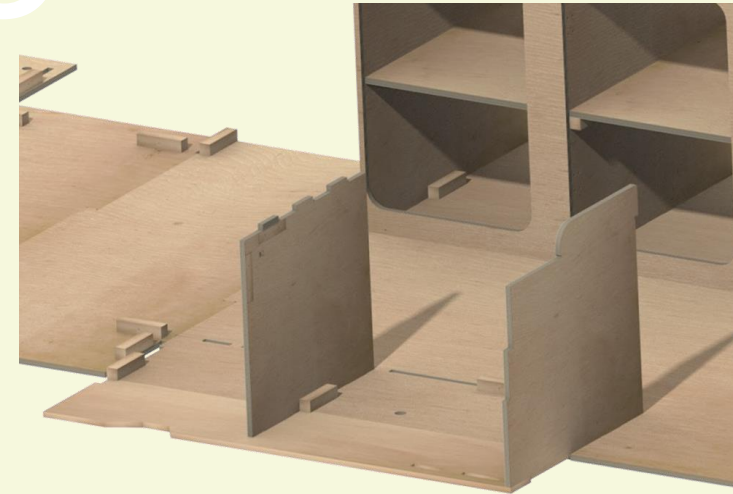

# 6

Repeat  
for B3

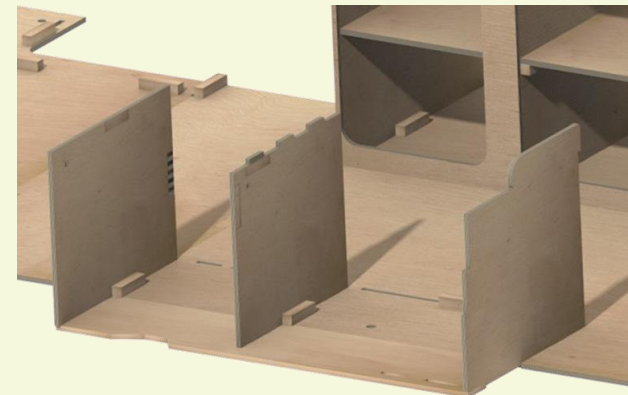

## Section B

# 7

Slot B4 into place, and secure with remaining pilot holes

Note, B4 has two 6" batten. These are secured from the engraved face of B4 and will be marked "PLY"

# 8

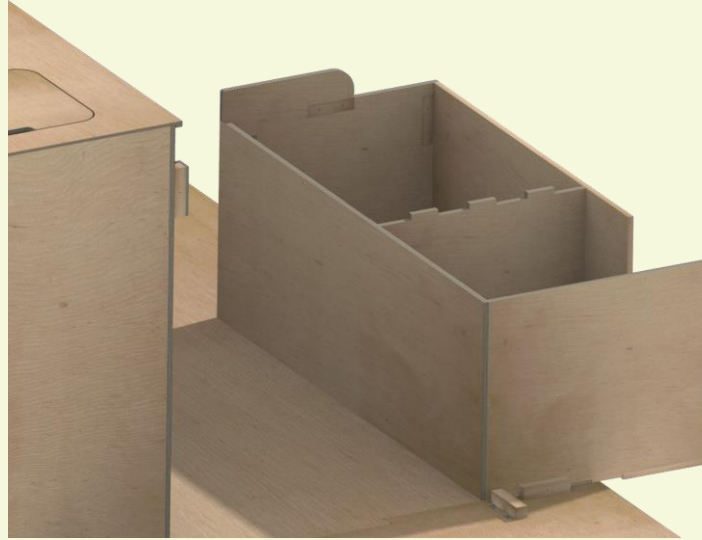

Panel B5 can now be slotted in place and secured down

B5 will secure to B1, B2 and B3

# 10

B7 can now be located as the top panel of the bench

# 9

The bench rail (B6) can now be secured in place on the slide door side of the bench.

The rail is located against the batten and secured in by 2 screws from the front face.

The table (T1, T2 & T3) can be used on either the kitchen rail of the bench rail.  
See Section 5 'The Table'

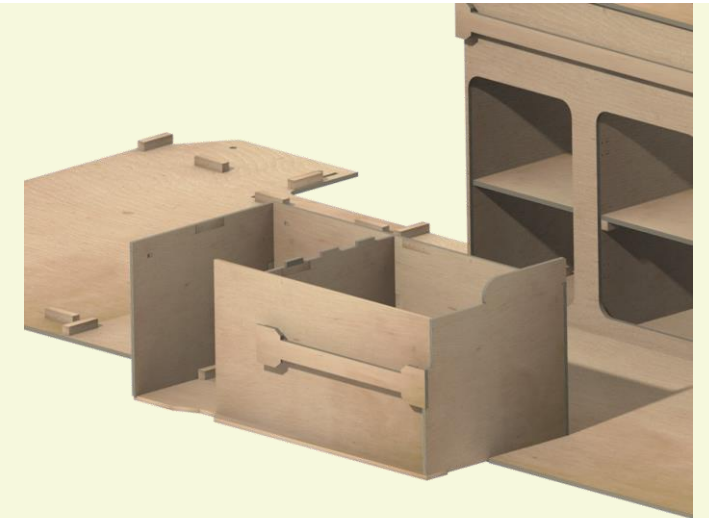



Panel B7 has two hatches, which are supported by four 45° batten for each hatch.

The two hatches use the 6” plywood batten with 2 holes

These batten are screwed in from the top, as the screw heads will be covered by the bench squabs.



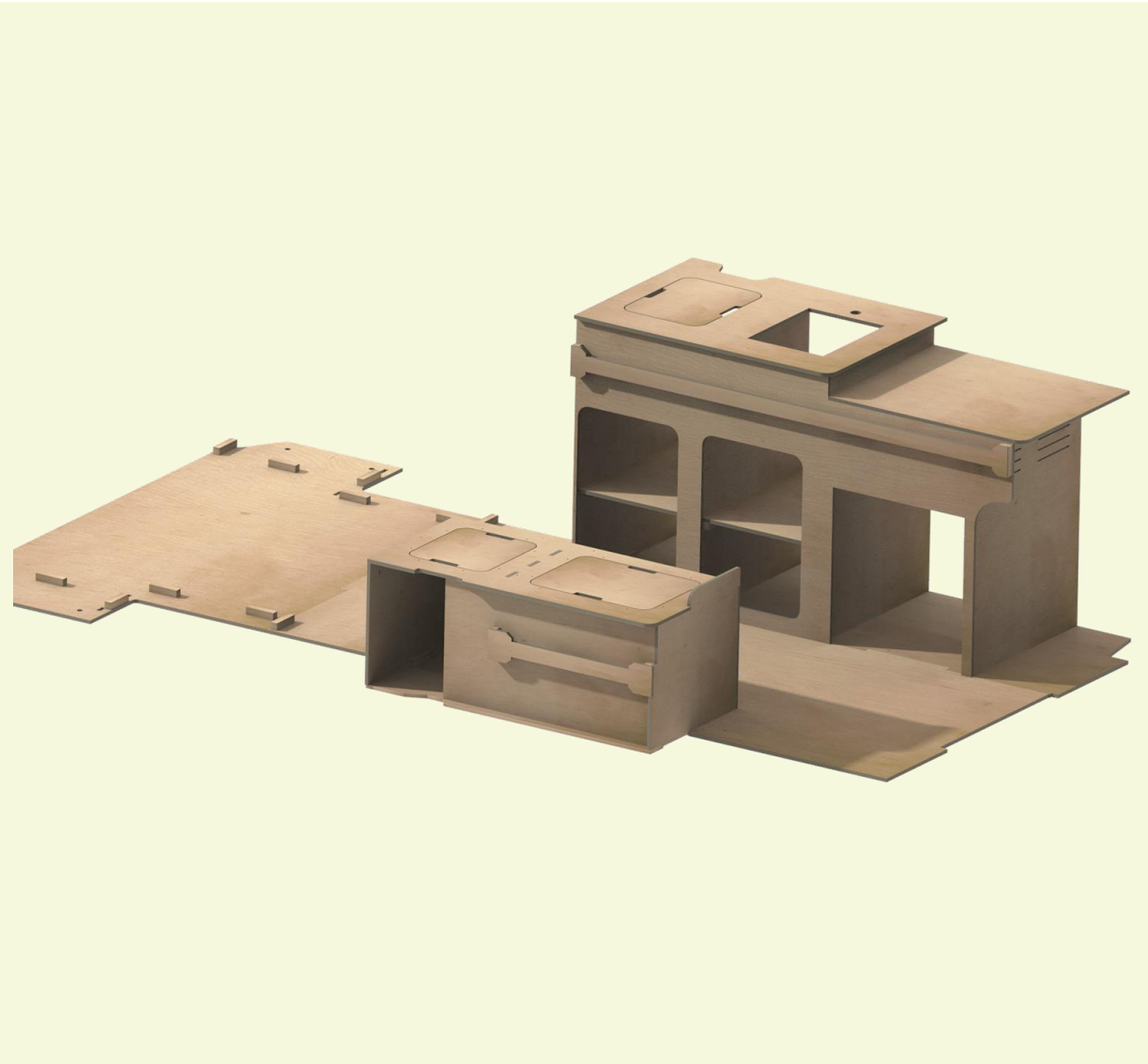

12

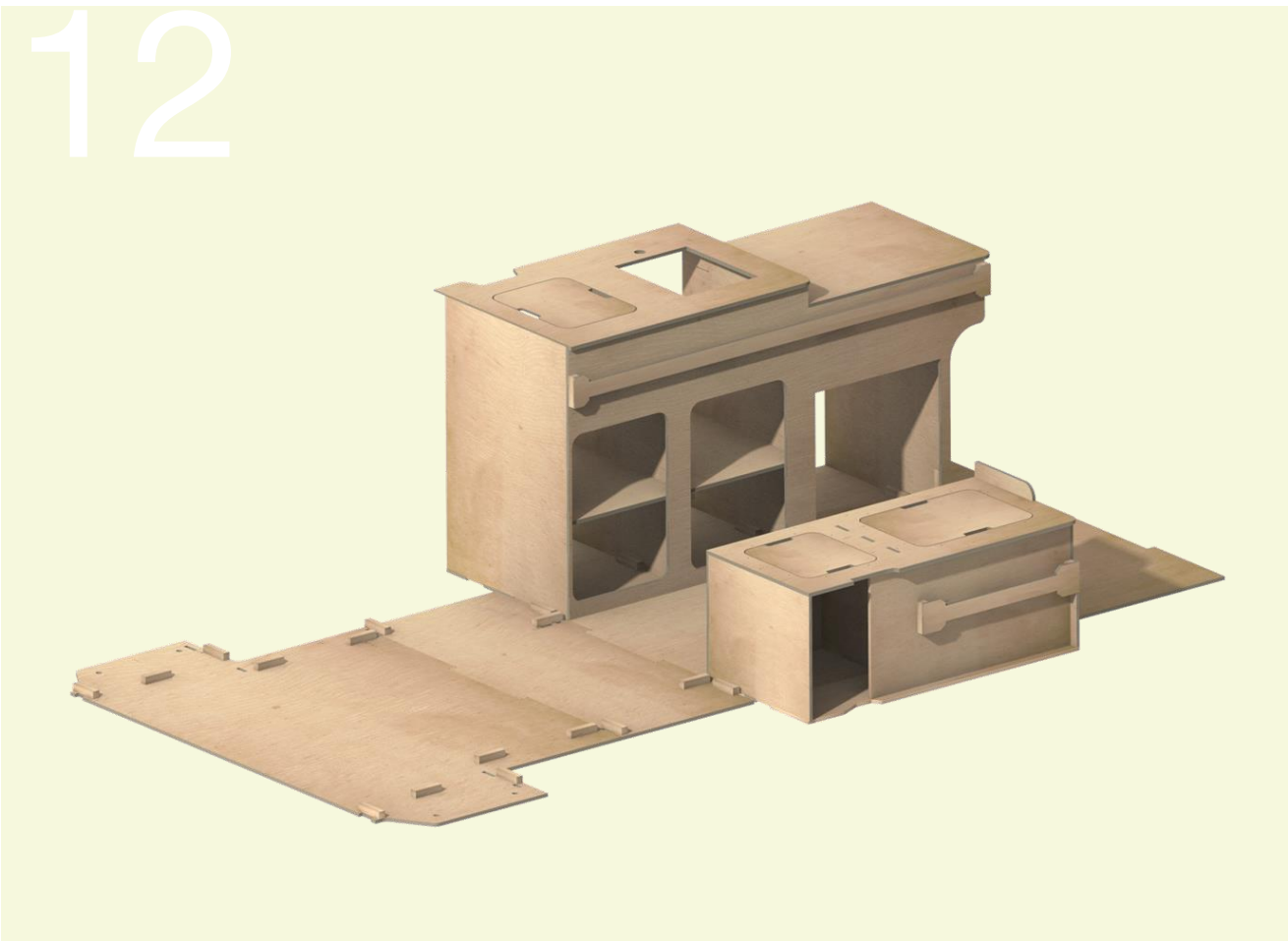

Section B is Complete

# 4. Section 'C'

## Section C

# 1

Find Panel C1 and attach all batten as per the symbols.

Slot C1 into place and secure down to the batten in the middle section of the floor

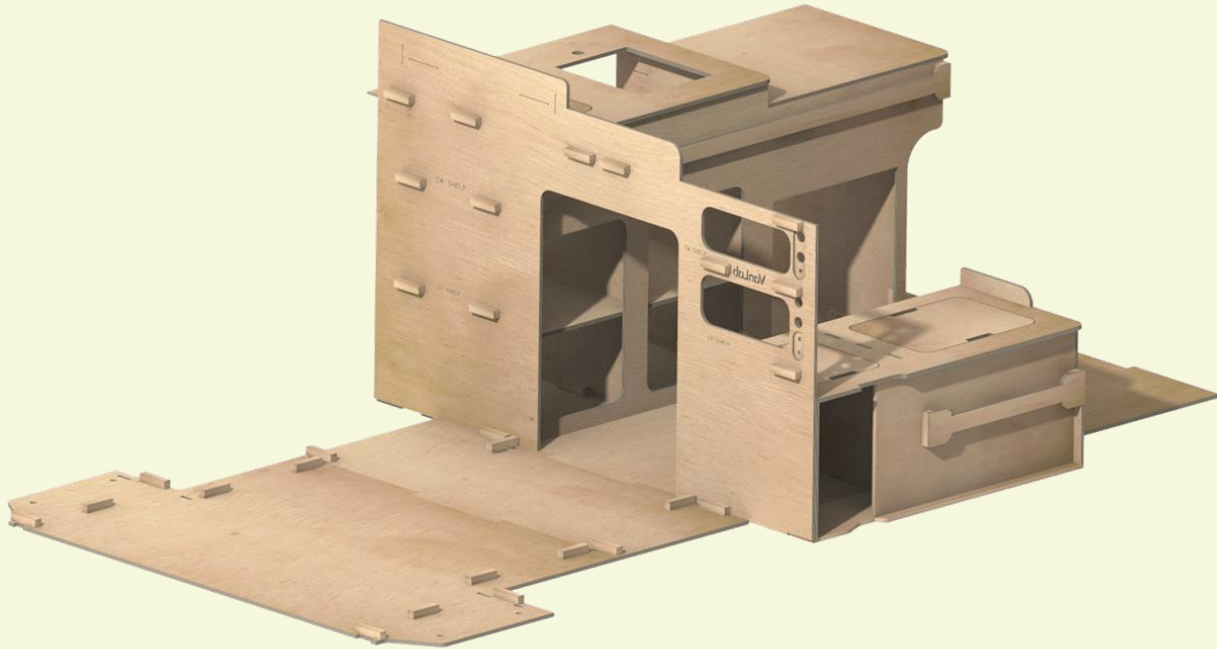

# 2

Repeat the process for C2

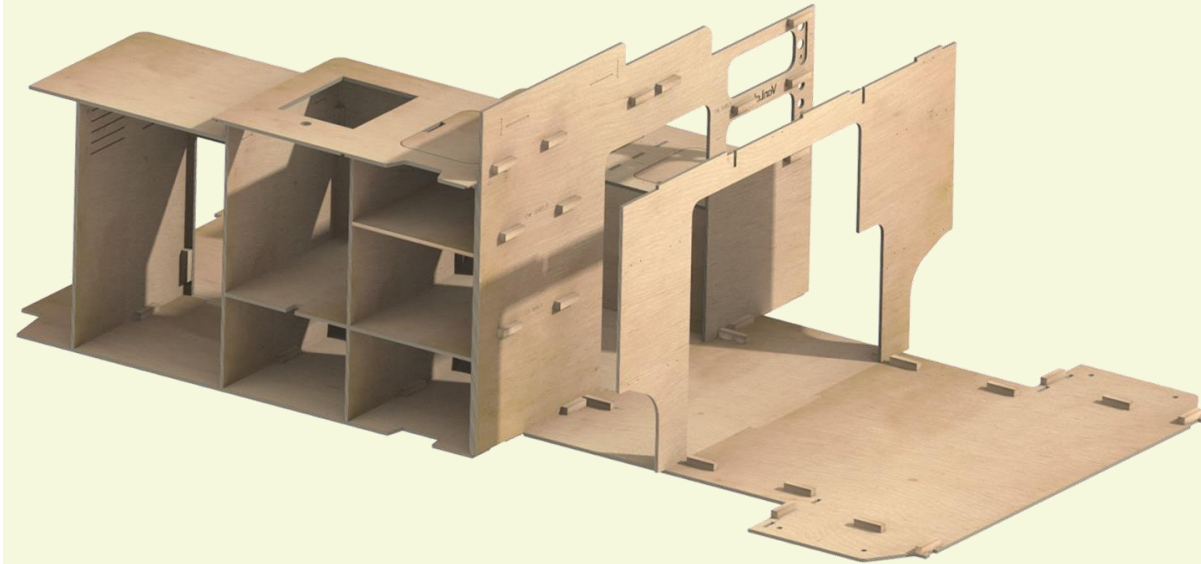

## Section C

# 3

C3, C4, C5 & C6 are all shelves which fit between C1 and C2.

The location of each shelf is identified by engravings



# 4

The shelves are all screwed in from the top, as per the kitchen shelves.



# 5

The upright panels of C7 and C8 can now be slotted into place and secured by screwing to the 4" batten.



6

C9 is fitted following the same process as C1 and C2.

Secure the batten to the part, secure the part to the floor.

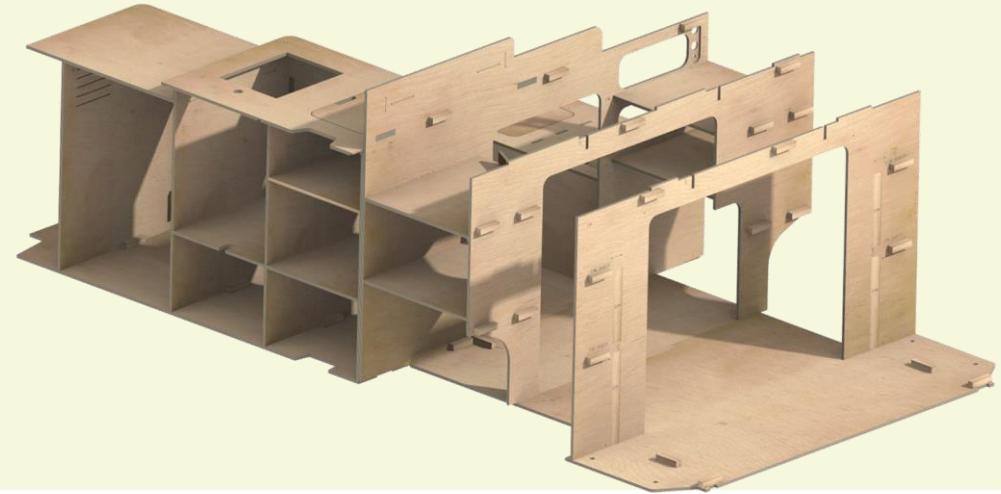

7

Now the main transverse structure is in, the longitudinal panels (C10 & C11) can be fitted.

These will be loaded in from the top and slotted into place. They will slot into the floor, but also slot into the transverse panels of C2 and C9.

Secure C10 and C11 in place by screwing into the 4" batten.

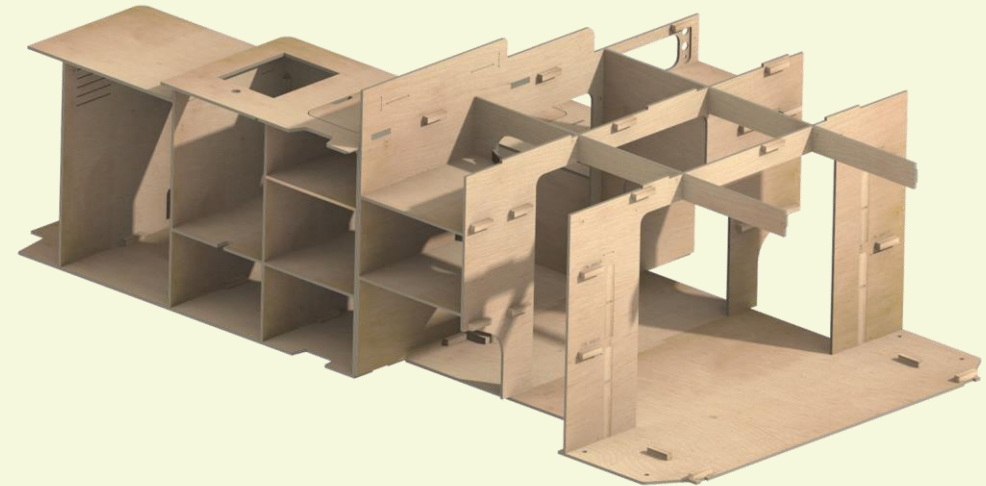



## Section C

8 The rear panel (C12) can be noted by the VanLab logo. This panel can now be fitted.

C10 and C11 have tabs that will slot into grooves in C12 and secure with vertical battens

Ensure all panels are slotted correctly to each other by checking top surfaces are flush.

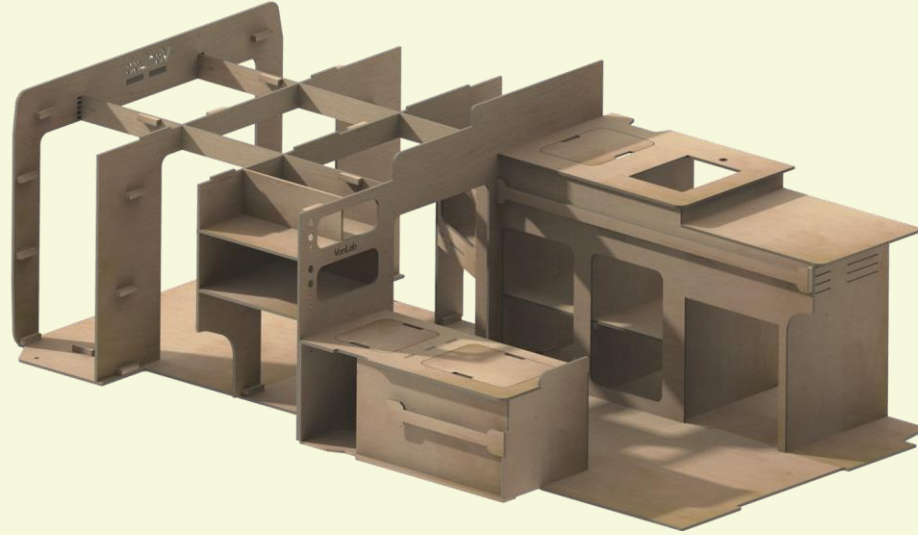

9

Ensure bed supports (C2, C9, C10 & C11) are flush before securing batten screws. These panels provide a flat base for the bed platform

9  
a.



## Section C

# 11

Panels C13 and C14 can be fitted. They are shelves between C2 and C8, on the left hand side of the van. Their position is etched on C2 and C8

They are secured into existing batten screwed from the top surface.



# 12

You can now repeat for C15 and C16. These are in the shelves between C10 and C12, behind the shelves you just fitted.

They are secured into existing batten from the top, following the same technique we just used

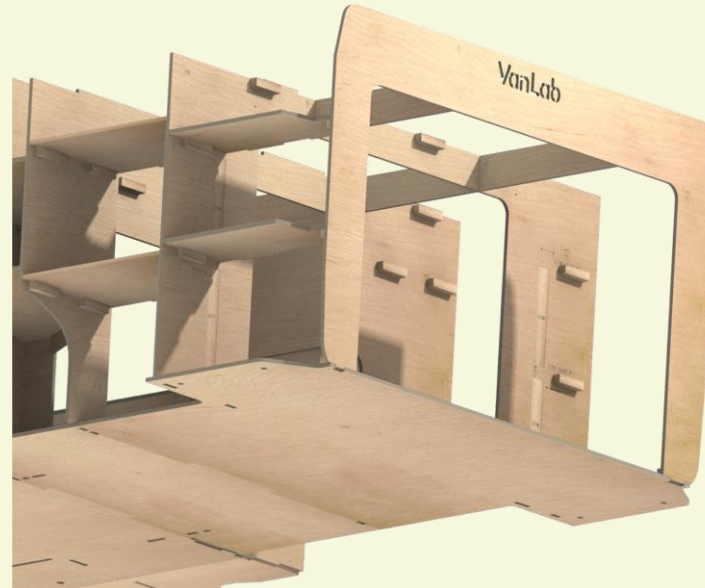

# 13

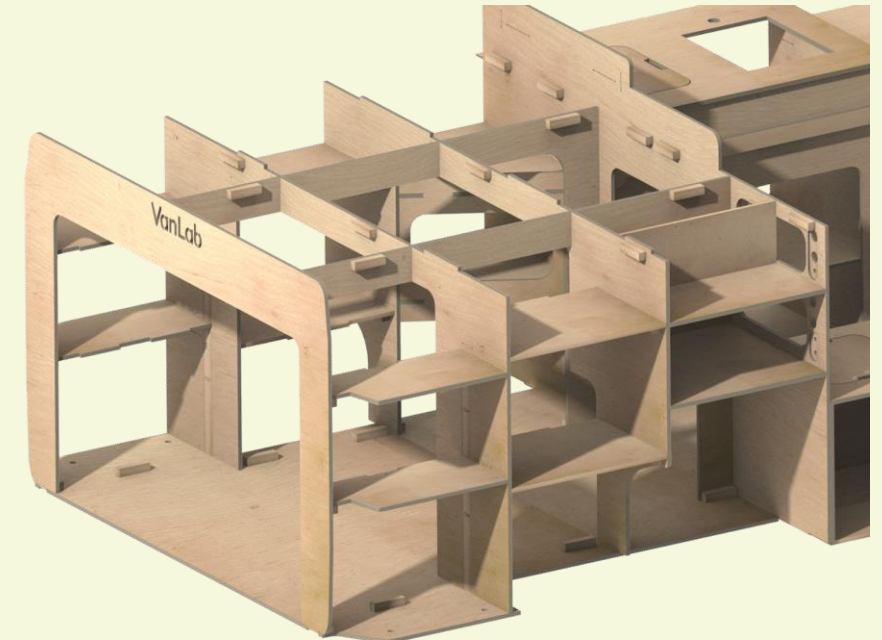

Steps 11 and 12 can now be repeated for C17, C18, C19 and C20 on the right hand side of the van.

These are the same shelves you just fitted, but on the right side of the vehicle.

# 14

C21 is a shelf end fence, which will secure the shelf and keep your shelf items safe in transit.

Find shelf C13, and check on the bottom. You'll note there is an instruction to fit C21.

^^^C21^^^

This shows you where to mount the shelf frame, C21

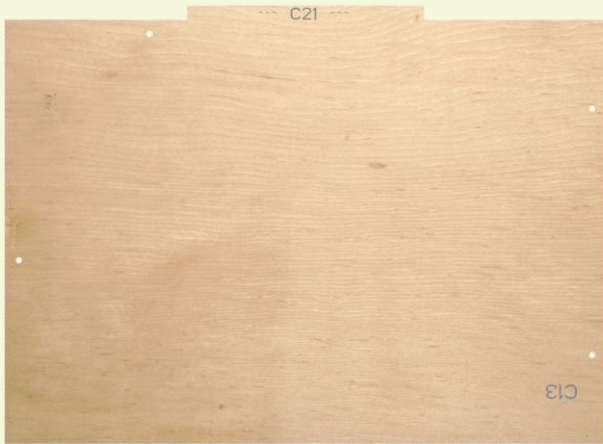

# 15

C21 secures in place by screwing into batten on the floor, C2, C9 and C13.

C21 has no door, it's an open shelf fence.

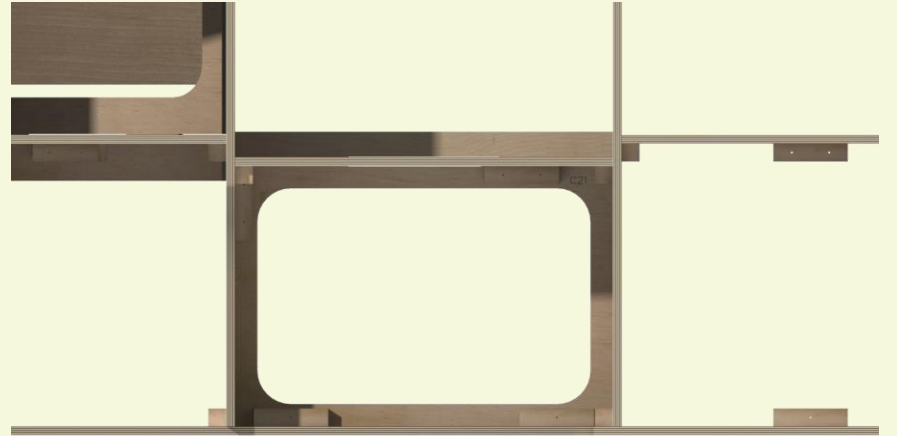

# 16

You can now repeat for C22, which is positioned above C21.

You will find the location instruction on the underside of shelf C14.

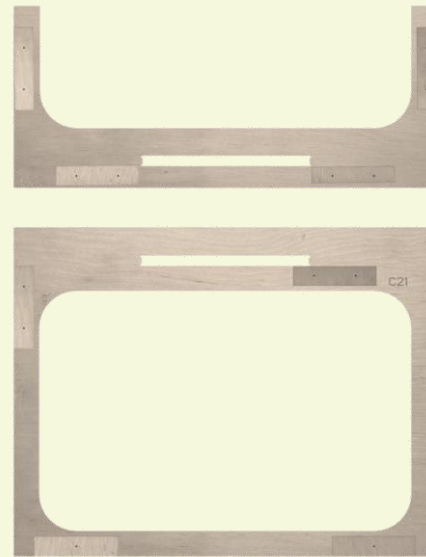

# 17

C23 and C24 can now be secured in place on the right

These two panels follow the same process as C21 and



# 18

We are now ready to fit C25 and C26. These two parts are the rear garage doors, and have several sections.

Let's start with finding C25. C25 can be secured between the transverse panels of C8 and C12 on the left hand side of the van. This part will slot into the rear shelves of C15 and C16. Secure in place using the batten.

Once in place, this process can be repeated for C26 on the right hand side.

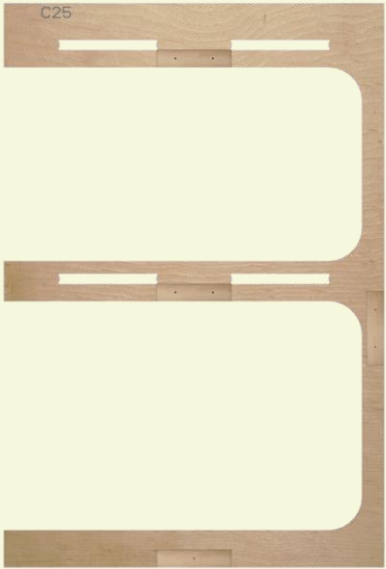

## Section C

# 19

You can now fit the rear door hinge plates. These plates are labelled C27, C28, C29 and C30. You must use the #8 x 7/8" screws for this part. These will be labeled "For C27-C30"

C27 & C29 = Left side  
C28 & C30 = Right side

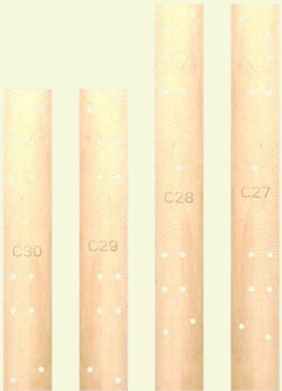

The location for these plates is labelled on part C10. Both their location and part number are engraved to help you locate these frames. They are secured in place using 5 screws:

- 2 at the top
- 1 in the middle
- 2 at the bottom

Note, the hole patterns in a square formation are for the hinges.



# 20

# 21

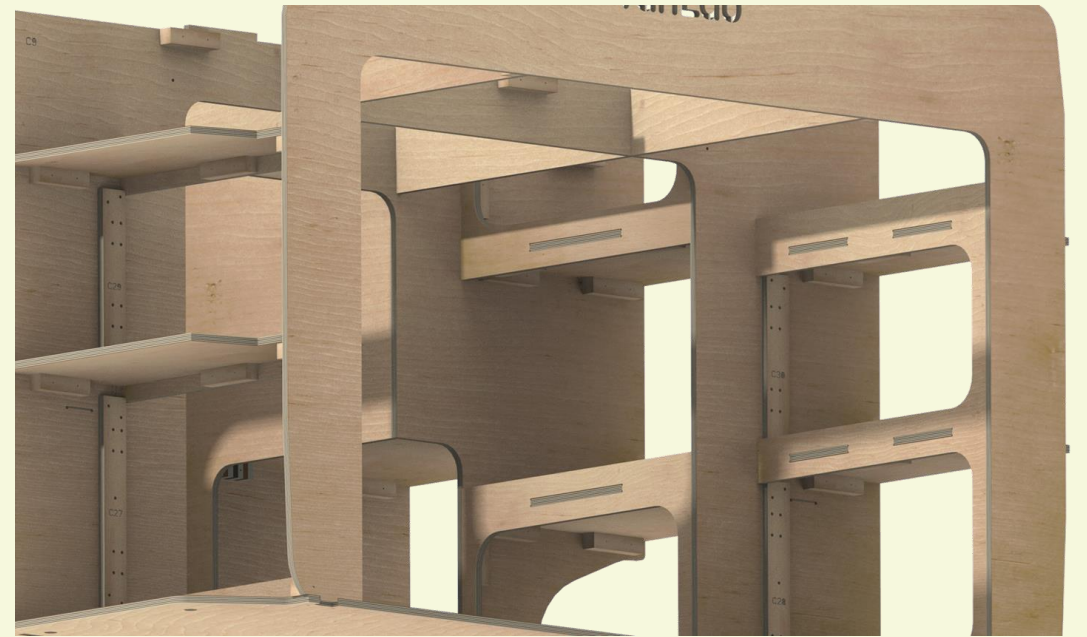

Once C27, C28, C29, C30 are fitted, C9 should look as above.

# 22



You can see 2 sets of 4 holes in a square pattern on each door; these are for the hinges. These hinge holes correspond to the same hole patterns on the doors. We advise that you open the hinges up to 180degrees before fitting. This makes it easier to secure in place.

- Using the #6 x 3/8 screws, secure the 4 hinge plates to the uprights of A3 and A4 using the supplied pilot holes
- With all 4 hinges in place, check which door is correct. NOTE: check the grain patten against panel A5 hole to make sure you have the correct door in the correct position.
- Holding the door in its open position and using the #6 x 3/8 screws, the open hinge plates can be secured to the door. Once all 8 screws are in place, the door is fitted and you can move on to the second door. Once fitted, close the doors to keep them stowed while we complete the rest of the build.



Starting at the top left door and base plate C29, work your way around the doors fitting to C27, C28 and C30.

Once secured in place, the doors should swing freely on the hinges and snap closed when closing.

# 23

# 24

We are now ready to fit the bed tops.

Find the two large slotted parts, as these are the bed tops. To define the orientation, the engraving is on the underside.

Lay the panel into place and allow it to slot onto the tabs of the existing frames. Once the bed panel has dropped into place, you can secure it through the pre-drilled pilot holes into the batten; ensure all pilot holes are secured.

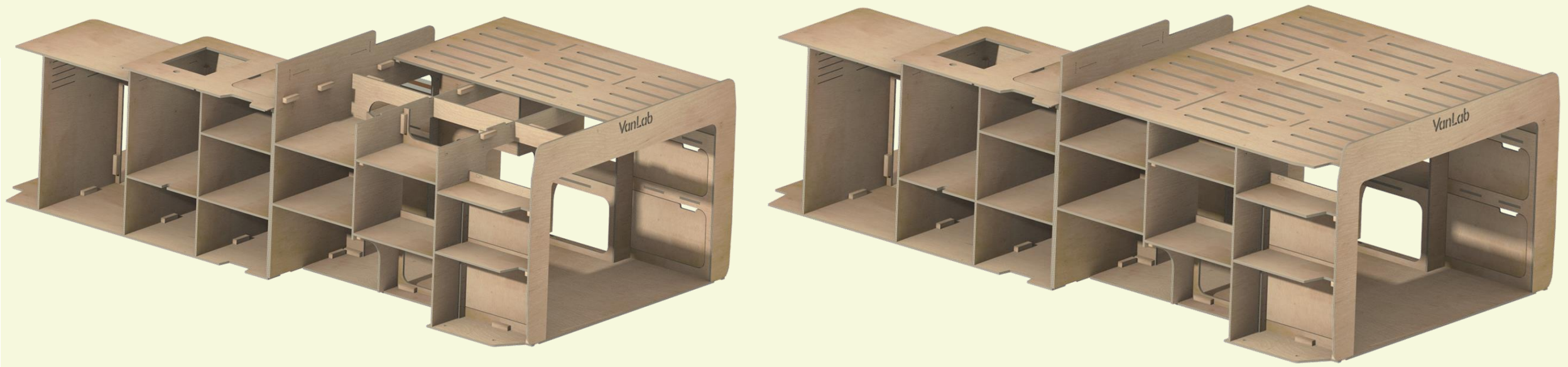

# 5. Table

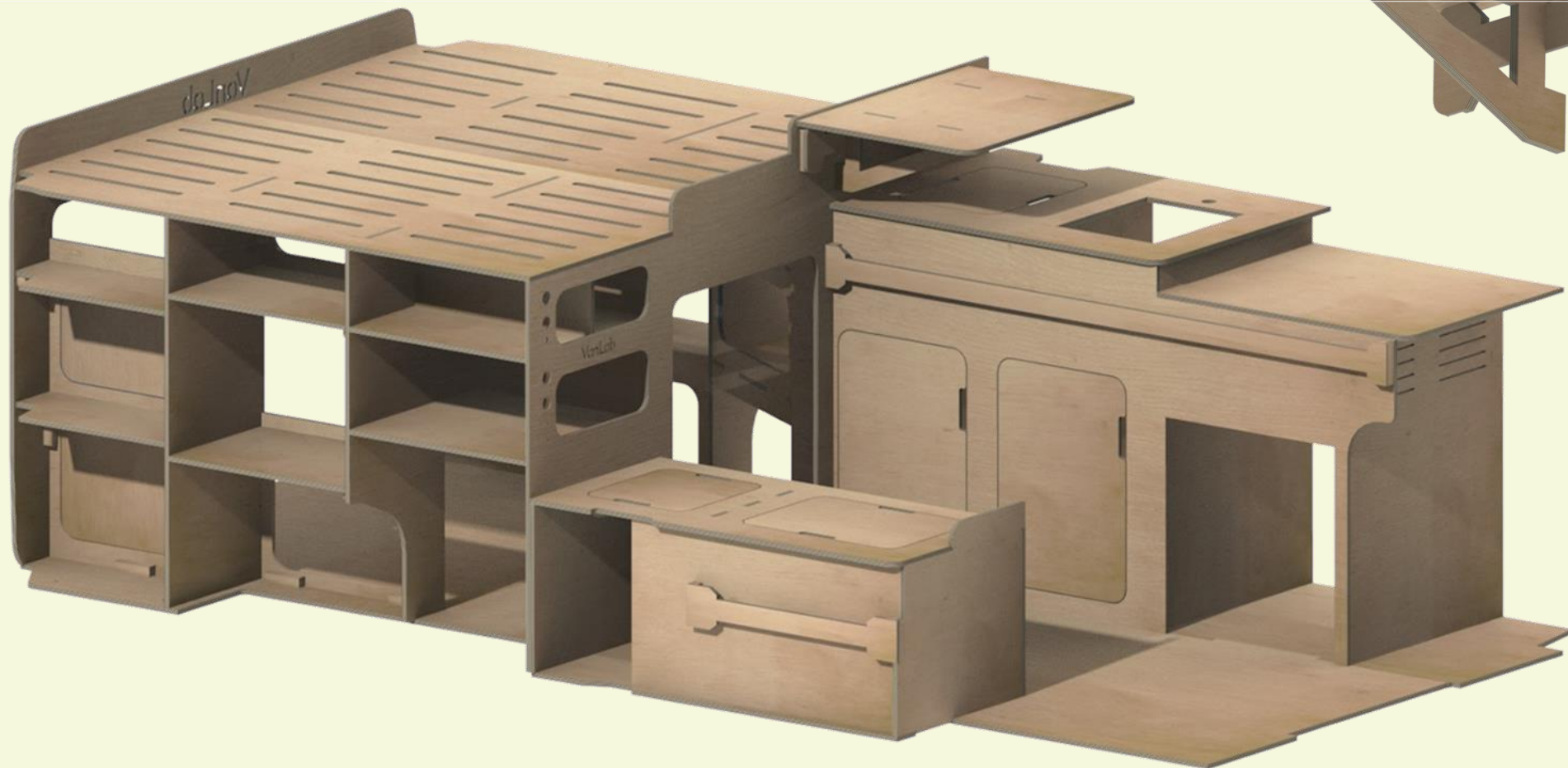



## Table

# 1

- The table is labelled T1, T2, and T3
- Secure the 4" batten to T1 and T2 as shown.

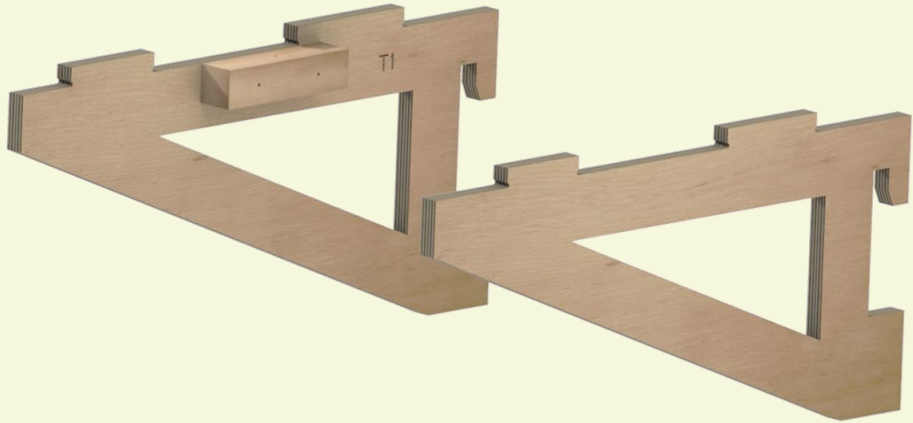

# 3

- The table can now be slotted onto the rails added in both Section A, B and C



# 2

- T1 and T2 slot into T3.
- They are then secured using a screw from underneath. This is the same process as securing the Kitchen benchtops down



The Table is Complete

# 6. Door Magnets

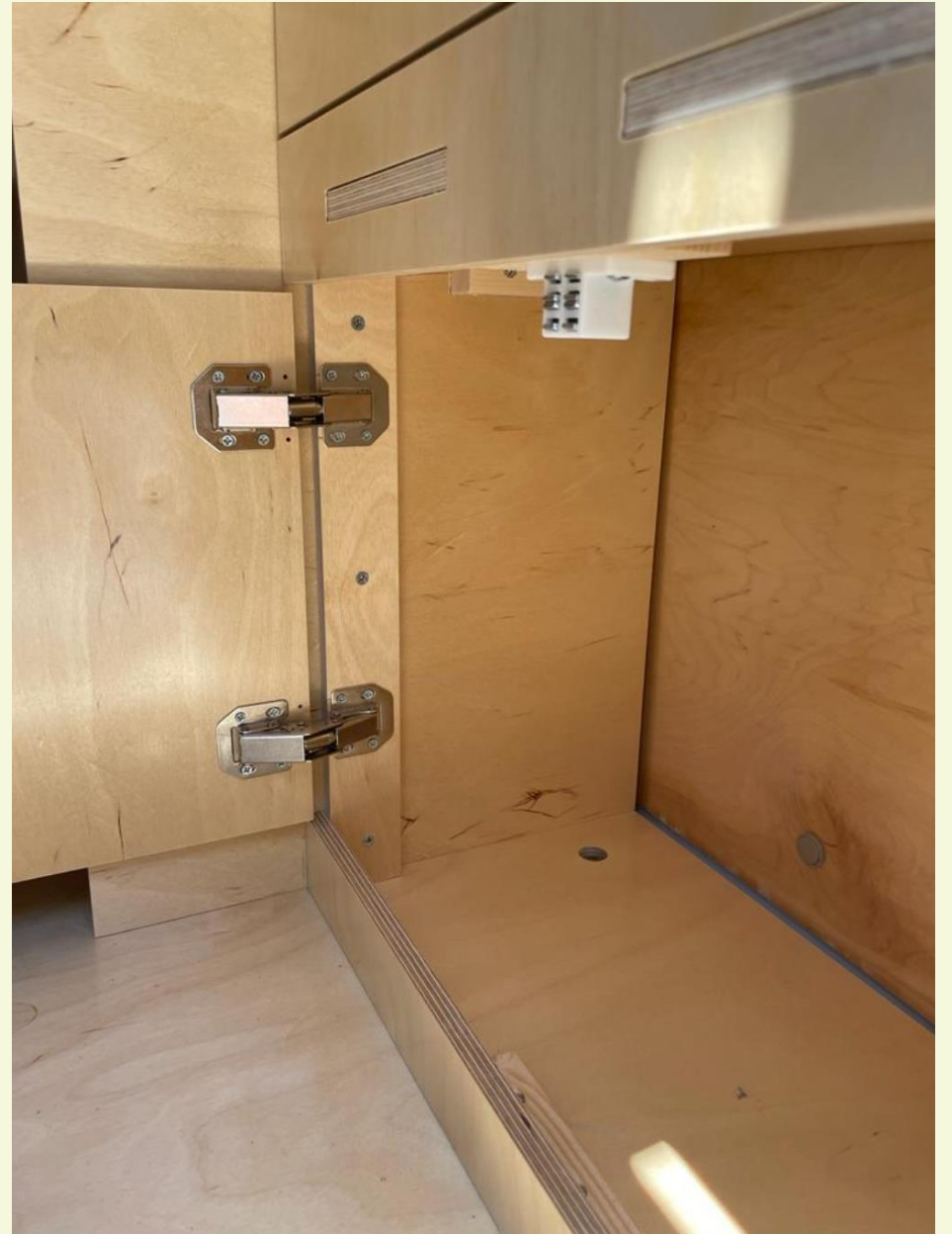

# 1

Door magnets are fitted to every swinging door. The magnets are two sections. The magnet plate and the magnet housing. The magnet plate mounts to the door with a single screw and the magnet housing mounts to the door frame.

## Magnet Plate

- The magnet plate is fitted to the door with a single screw using the predrilled hole.

## Magnet Housing

- The magnet housing is mounted to a support batten on the door frame. This part has NO pilot holes and is lined up by you when fitting.

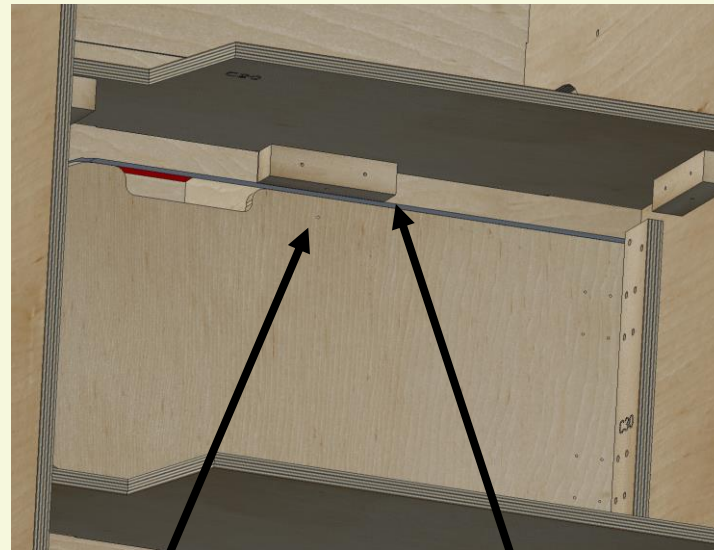

Magnet plate  
Pilot hole

Magnet Housing  
Batten

We suggest fitting the magnet housing first. Take the magnet plate and connect to the magnet housing, so you have a single assembly.

# 2

- Hold the magnet assembly base in the correct position against the support batten. See photo on previous page for alignment.
- Now the base is set, you can now line up the front face of the magnet plate, to the back face of the door frame. i.e the location the door will sit when closed. This will align the magnet housing correctly.
- Once you have correctly aligned the magnet housing, secure in place with the two screws. We suggest that you don't pull these screws tight yet, so you have some flexibility to locate the magnet housing block.
- You can now remove the magnet plate, and screw this into the door using the single pilot hole.
- To check alignment, close the door and ensure that the door closes flush to the frame. If the door under- or over-closes, you can adjust the location of the magnet housing accordingly.

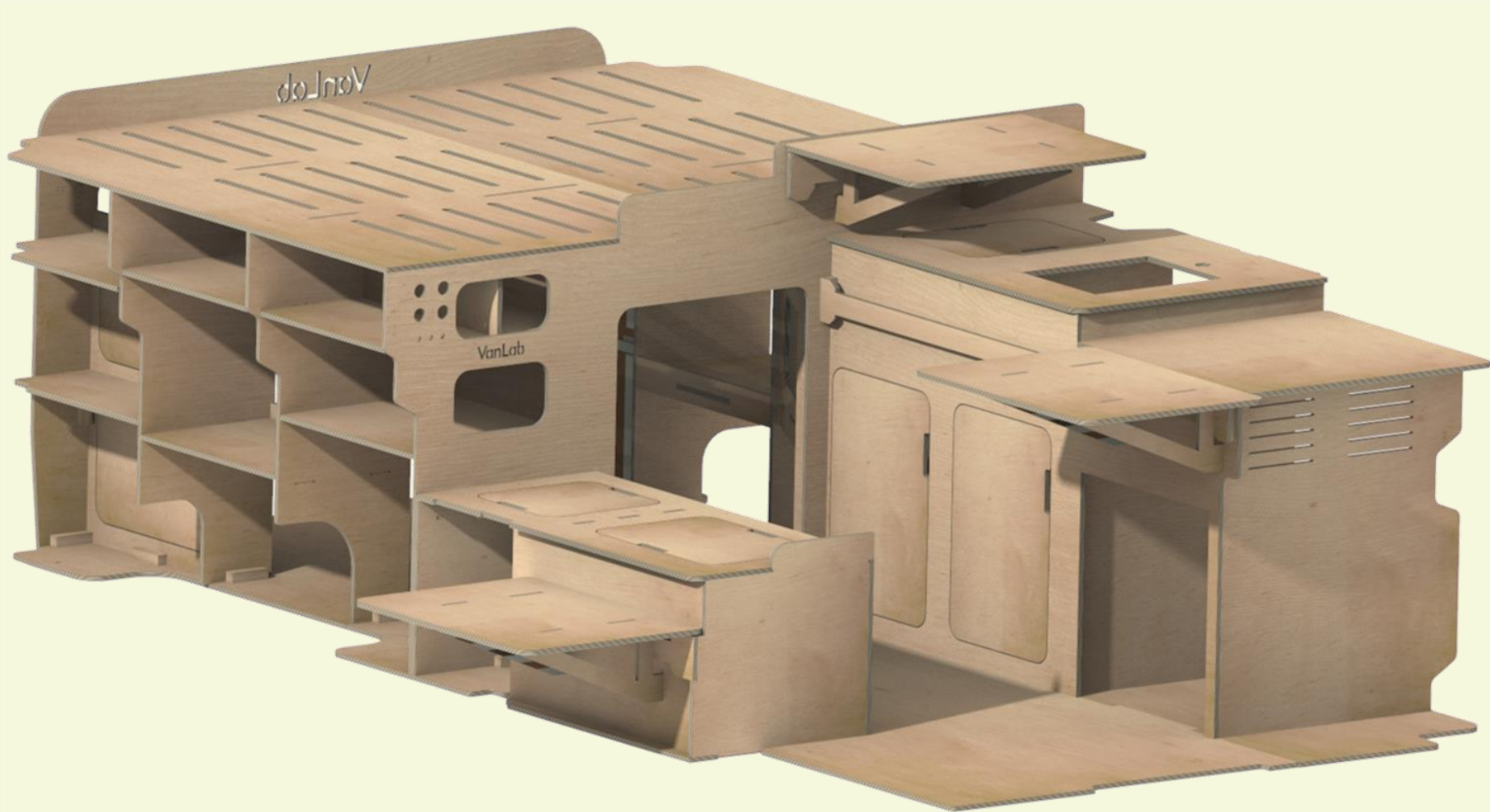

Congratulations, your VanLab Kit is now completed.

## Additional and Complementary Products

Please additionally find info below on our recommended / compatible appliances as discussed.

### Front loading fridge:

- Dometic CRX 50T
- [https://www.dometic.com/en-us/professional/truck-solutions/truck-refrigerators/dometic-crx-50t-231419?adcopylabel=&contenttype=&gclid=EAlalQobChMijYKMn67C9wIVQj2tBh1RhwqREAQYAiABEgL4f\\_D\\_BwE](https://www.dometic.com/en-us/professional/truck-solutions/truck-refrigerators/dometic-crx-50t-231419?adcopylabel=&contenttype=&gclid=EAlalQobChMijYKMn67C9wIVQj2tBh1RhwqREAQYAiABEgL4f_D_BwE)

### Sink & Faucet

- Ruvati 15 x 15 inch Workstation Drop-in Topmount Bar Prep RV Sink 16 Gauge Stainless Steel - RVH8215. Available at Amazon
- [https://www.amazon.com/dp/B077NL6TDW/ref=cm\\_sw\\_r\\_cp\\_api\\_i\\_AEA13JN6W8934S92RPH9?\\_encoding=UTF8&psc=1](https://www.amazon.com/dp/B077NL6TDW/ref=cm_sw_r_cp_api_i_AEA13JN6W8934S92RPH9?_encoding=UTF8&psc=1)
- VFausit Commercial Stainless Steel Laundry Single Handle Pull Out Kitchen Faucets Matte Black. Available at Amazon
- [https://www.amazon.com/dp/B08JPWRSL3/ref=cm\\_sw\\_r\\_cp\\_api\\_i\\_dl\\_X90KM2NX2KZ2JSVF0MYS](https://www.amazon.com/dp/B08JPWRSL3/ref=cm_sw_r_cp_api_i_dl_X90KM2NX2KZ2JSVF0MYS)

**Gas burner:** Note, you will need to cut a hole for the integrated one or use a table top burner

- Ramblewood GC2-37P (LPG/Propane Gas) high efficiency 2 burner gas cooktop, ETL Safety Certified. Available at Amazon
- [https://www.amazon.com/dp/B06ZXYZGQT/ref=cm\\_sw\\_r\\_cp\\_api\\_i\\_KK9QENZ41KX1Q63FD95C?\\_encoding=UTF8&psc=1](https://www.amazon.com/dp/B06ZXYZGQT/ref=cm_sw_r_cp_api_i_KK9QENZ41KX1Q63FD95C?_encoding=UTF8&psc=1)

# VanLab

For more information or help email:  
[info@wearevanlab.com](mailto:info@wearevanlab.com)