

A close-up photograph of a light-colored wooden structure, possibly a desk or a piece of furniture. The word "VanLab" is engraved in a clean, sans-serif font on the side of the wood. The wood grain is visible, and there are some dark spots or knots. The lighting is soft, highlighting the texture of the wood.

VanLab

Fitting Guidelines

Nissan NV200

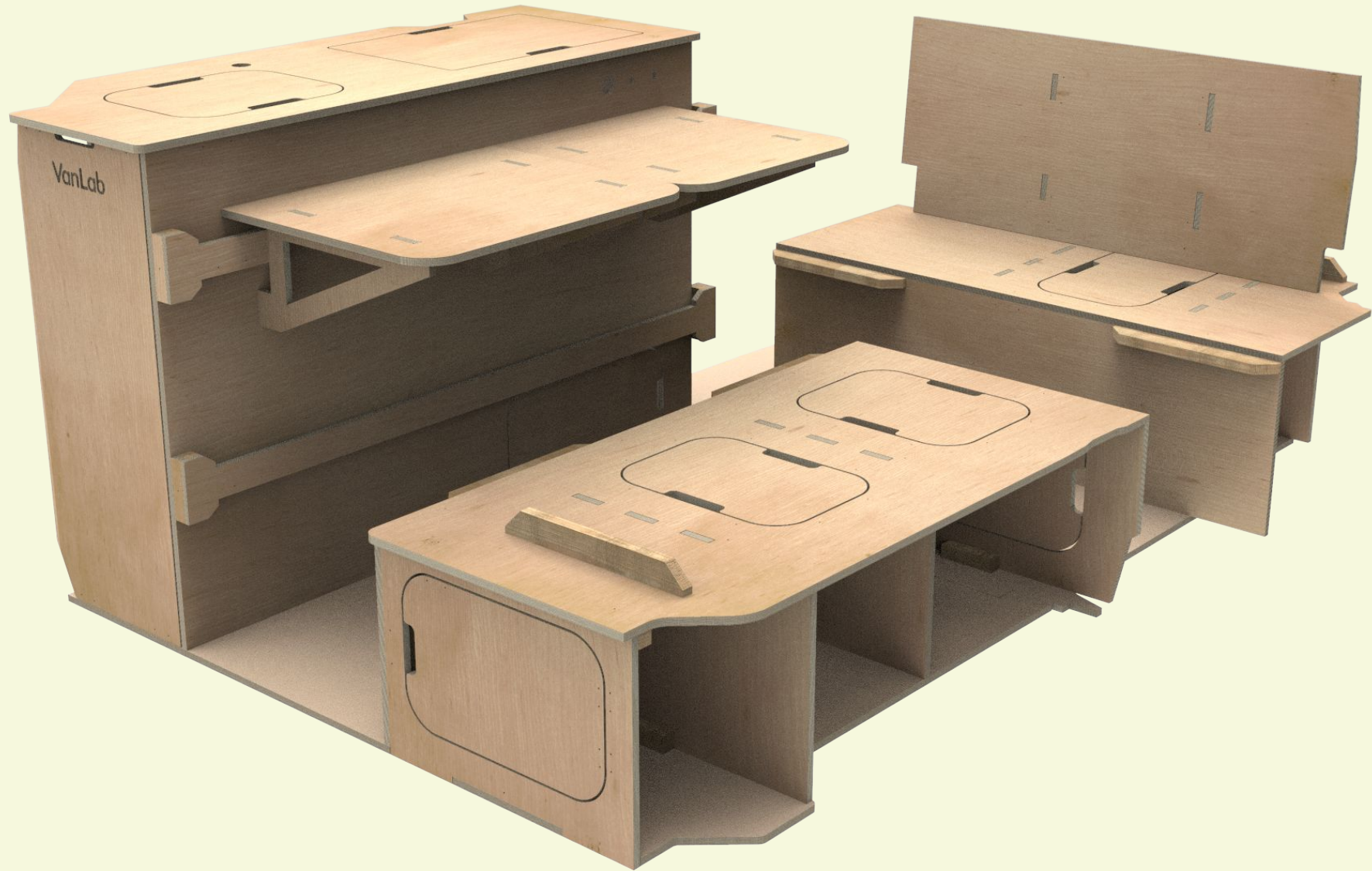

Parts

We provide all the parts you will need to put your kit together. We also provide some extras, just in case you lose one.

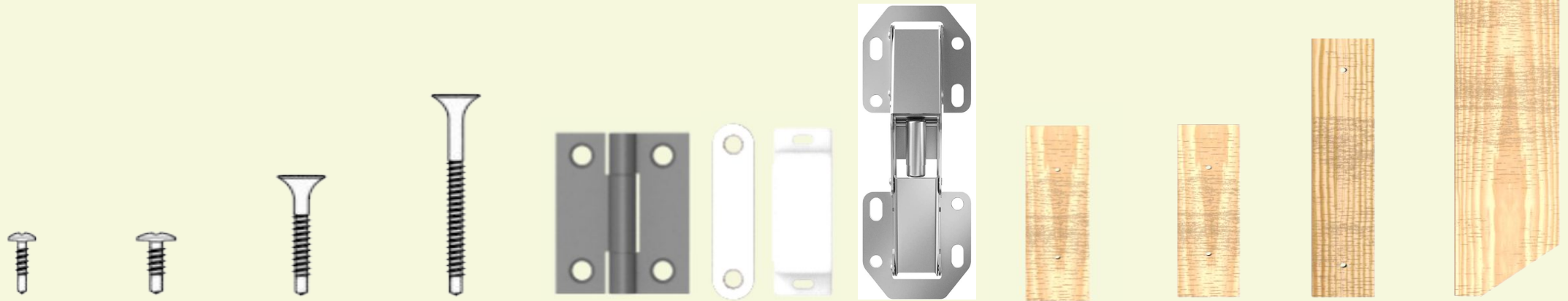

Size	#6 x 5/8"	#6 x 3/8"	#8 x 1 1/4"	#8 x 1 5/8"				4" Batten (Plywood)	4" Batten (Pine)	6" Batten (Plywood)	12" Batten (Pine)
Use	For C12 ONLY	All hinges and magnet catch plate	4" & 6" Batten	12" Batten	Cabinet Doors Hinges	Door Catches	Rear Door Hinges	Kitchen Rails	General Build	Hatches	Bed Rails
Quantity	12	70	320	14	8	6	2	6	90	22	8

Content

The Rules & Process

Section A

Section B

Section C

Finishing Touches

The Rules & Process

The Rules

Batten

Batten has 2 holes on one side and 1 hole on the other

- Always screw the 2 first (A)
- Then the 3rd (B)

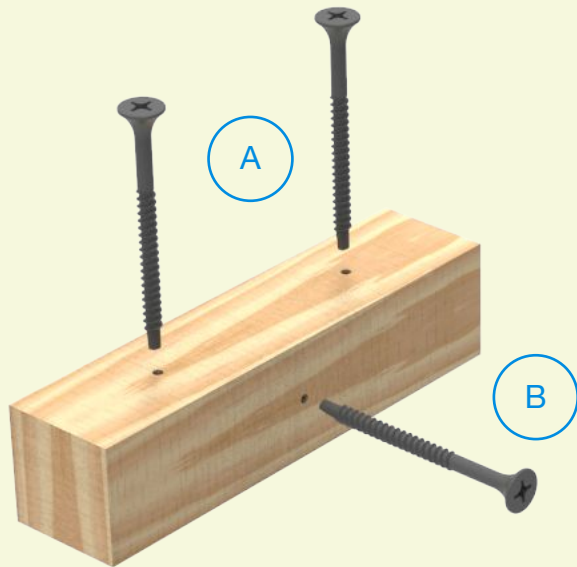

Panel Symbols

The panels have symbols to show you the location of the batten and how to fix the part. You have 3 symbols: The Rectangle, The Crosses and

The Rectangle

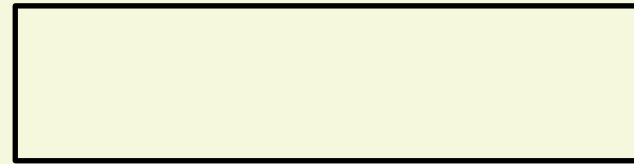

Place the batten over the box on the face you are looking at.
Screw into panel from the side you're looking at and screw through batten first and into the panel

The Crosses

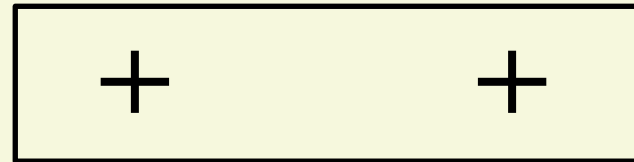

Place the batten over the box, on the face you are looking at.
BUT, screw from the opposite side

The Line

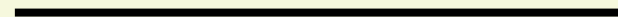

Place the batten on the opposite face of the panel.
Screw from the side you're looking at.
In this case, screw through the panel first and into the batten

Key Tip!

Partially drive the screws into the battens separately before fastening to the panel for easier pilot hole location (See below)



Use the same method when putting the screws through the panels first.



The Process

1 Batten on floor

First, add your batten to the section of flooring you are about to fix your first panels to (this will be section A).

NOTE: Ensure the flooring sits flat on the van floor. It should be central between the plastic trims of the slide doors, not overlapping on either side.

Next, add batten to the individual panels that go with that section

Eg batten section A of the flooring, then move on to Section A 'panels'.

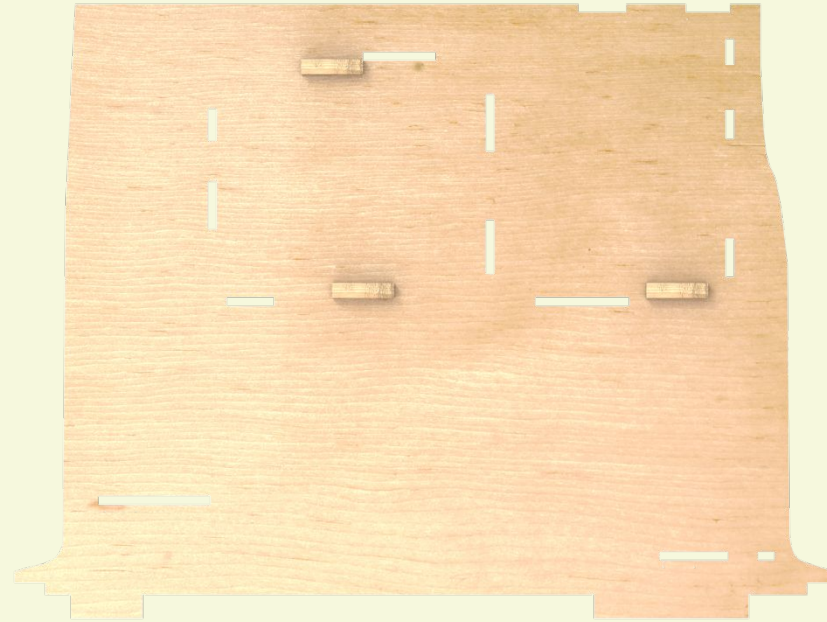

2 Batten on panel

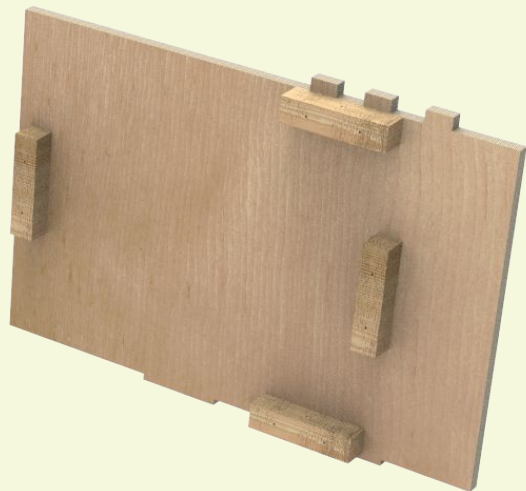

3 Fit panel

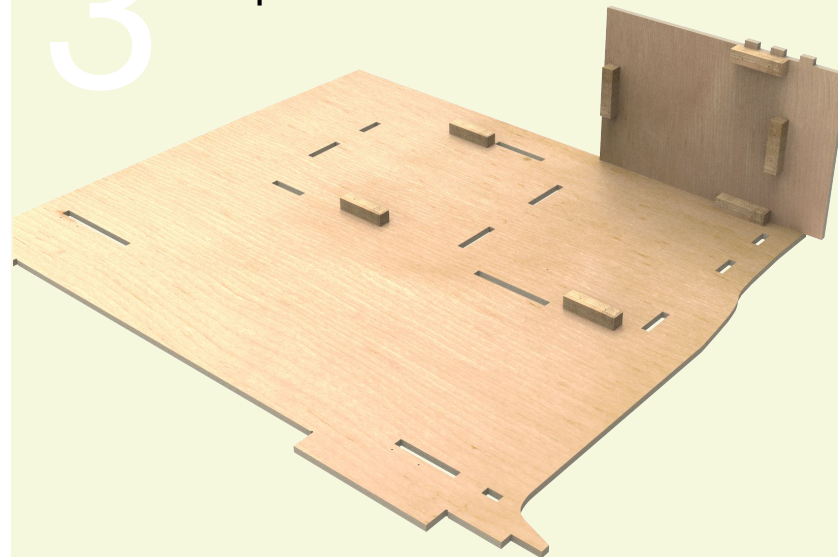

4 Repeat

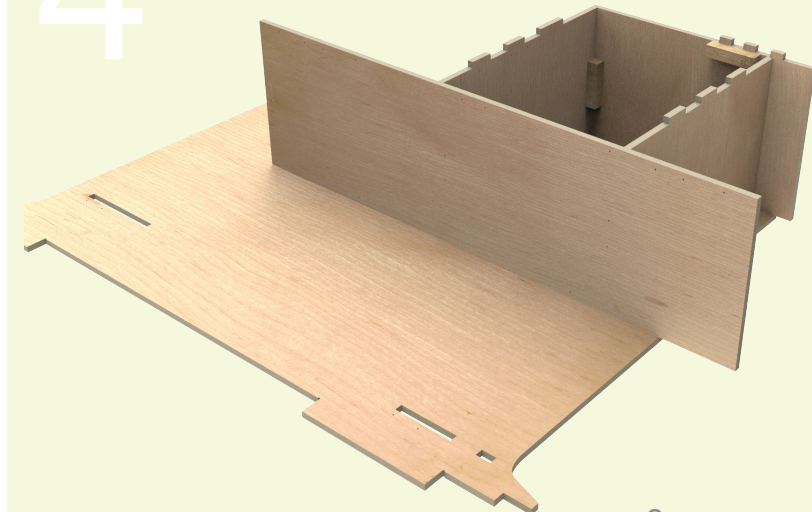

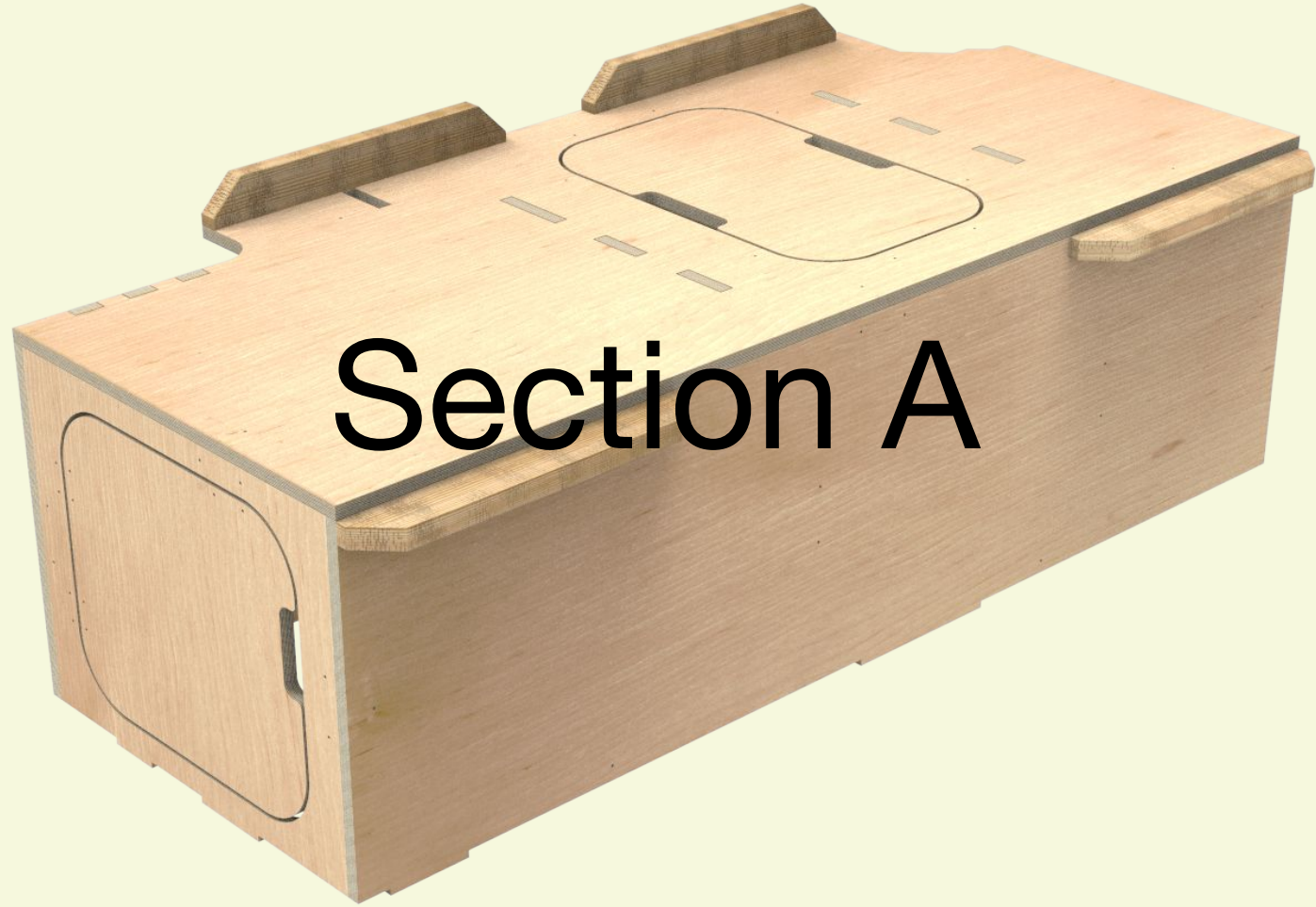

Section A

Section A

1

Screw batten into your first part of floor inside your van.

Batten location shown by 2 pilot holes 2 inches apart. There are 3 locations.

- Use 32mm screws for 4" and 6" batten
- Use 45mm screws for 12.5" batten

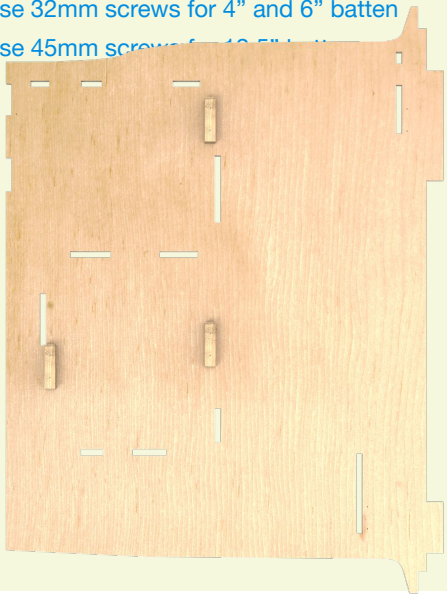

3

Fit all batten to panel A1.

Note, symbols indicate direction of screw (screw into panel first then batten)

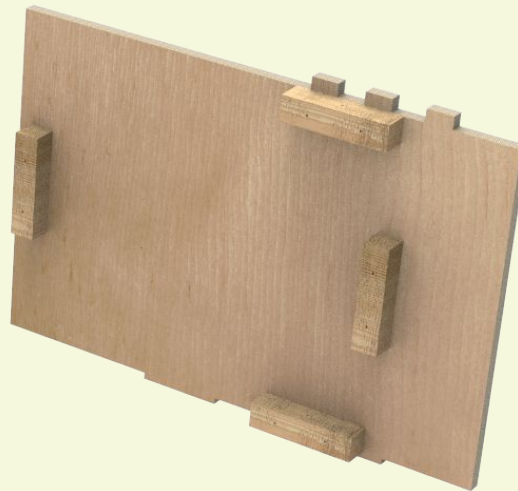

5

Secure A1 in place by fastening any remaining pilot holes.

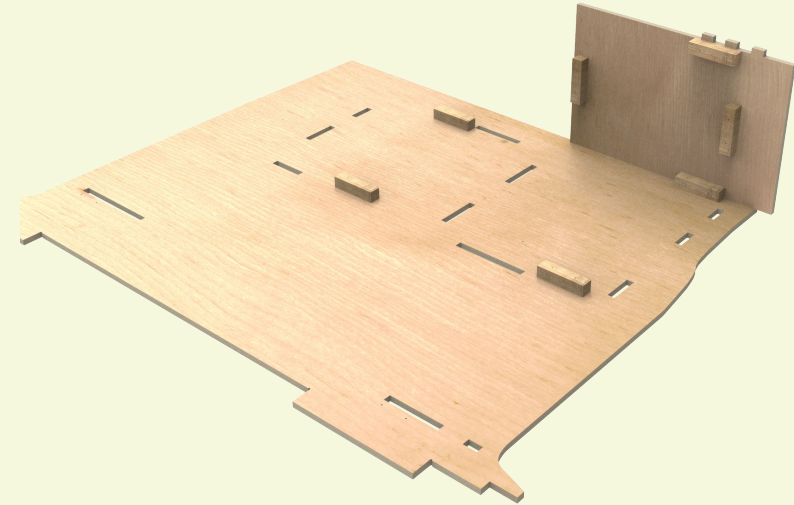

2

Find Part A1

4

Slot A1 in place (see marking on floor).

Section A — continued

6

Find panel A2.

Locate in A2 slot on floor and secure in place. (As normal, screw panel to batten)

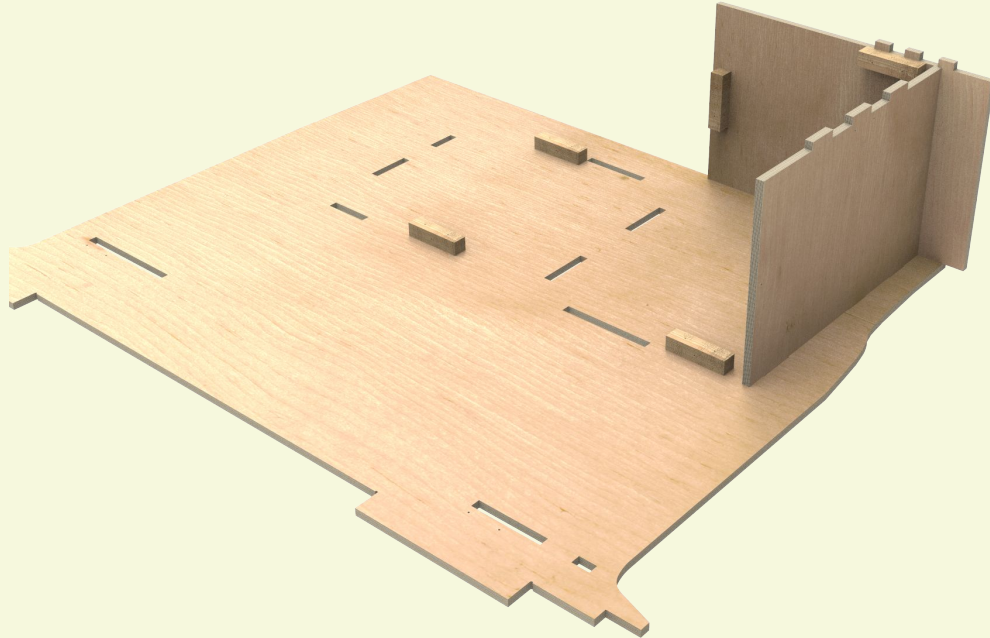

8

Secure A1 in place by fastening x2 12.5" batten to A6.

Then complete A1 by fastening x2 12" batten to A5.

Note: Hatch to be fitted at the end

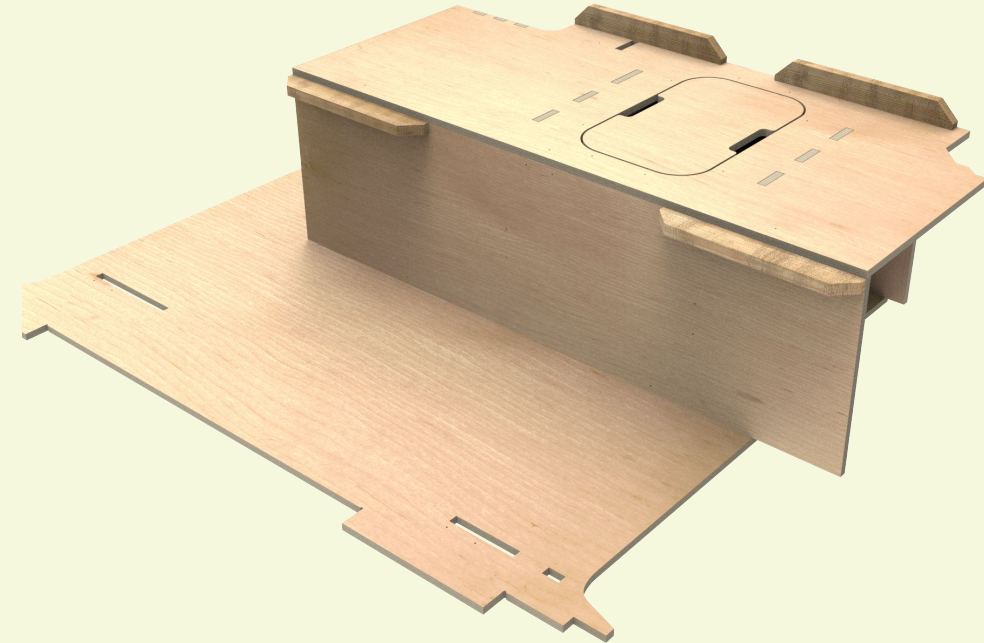

7

Repeat for A3 through A6.

(Reminder: A5 & A6 both need 12.5" battens)

Section A is completed.

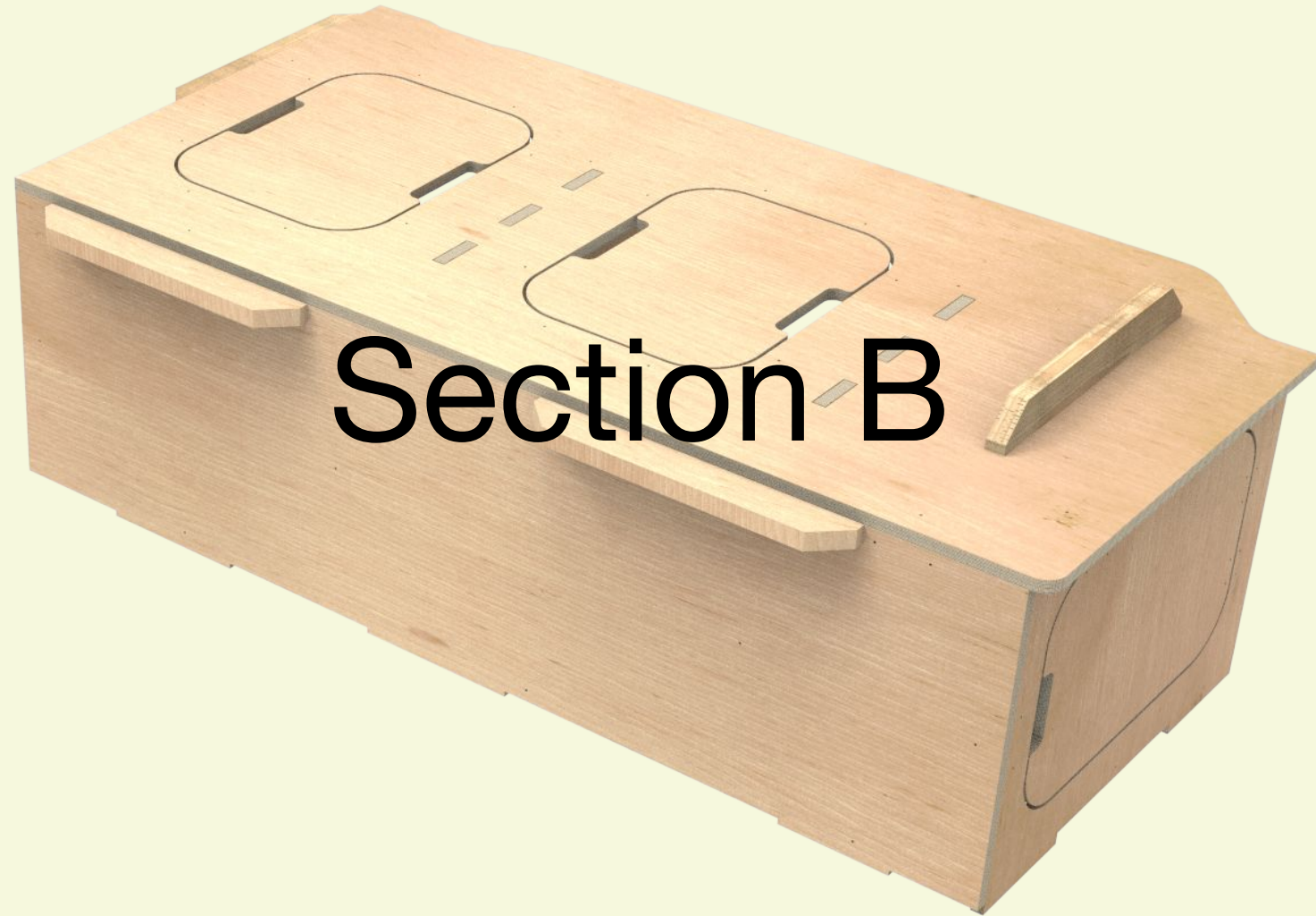

Section B

Section B

1

Screw batten into second floor piece.

Batten location shown by 2 pilot hole 2" apart. There are 7 locations.

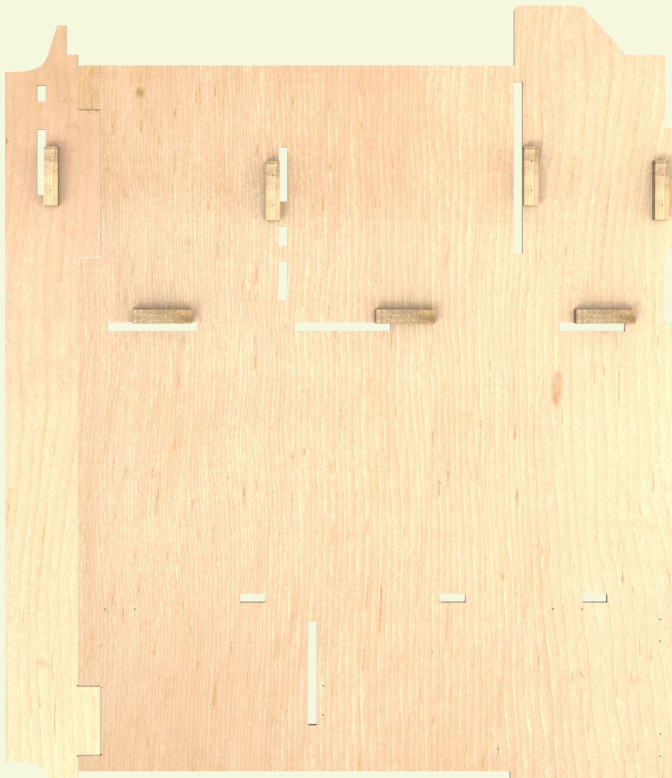

2

Find Panel B1

3

Fit all batten to panel B1.

Note, symbols indicate direction of screw (screw into panel then batten).

4

Slot B1 in place

(see marking on floor).

5

Secure B1 in place by fastening any remaining pilot holes.

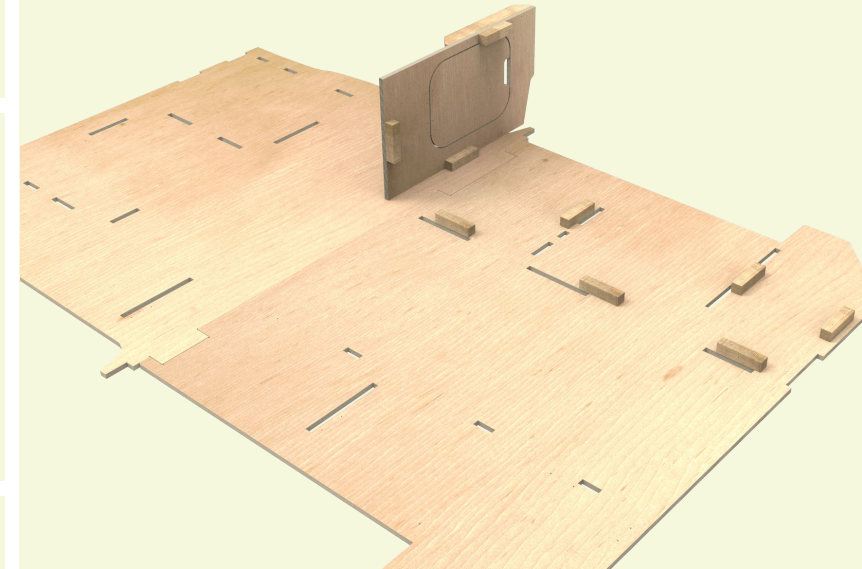

The Rules

Batten

Batten has 2 holes on one side and 1 hole on the other

- Always screw the 2 first (A)
- Then the 3rd (B)

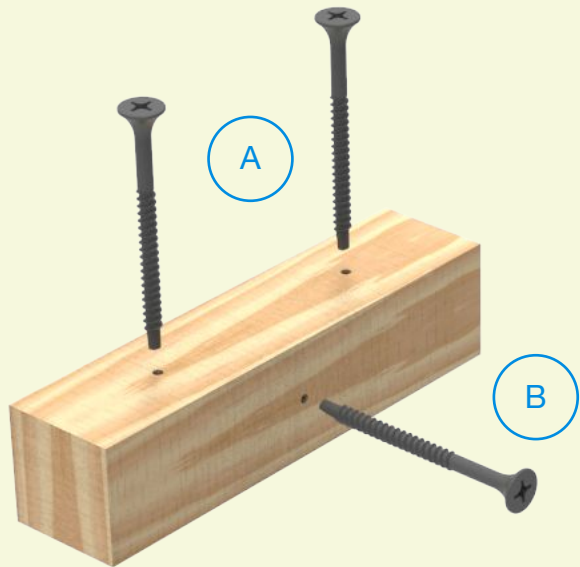

Panel Symbols

The panels have symbols to show you the location of the batten and how to fix the part. You have 3 symbols: The Rectangle, The Crosses and

The Rectangle

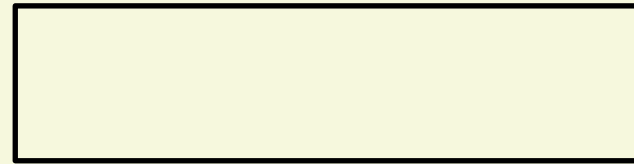

Place the batten over the box on the face you are looking at.
Screw into panel from the side you're looking at and screw through batten first and into the panel

The Crosses

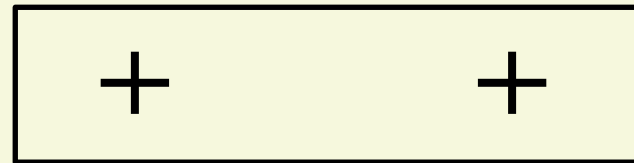

Place the batten over the box, on the face you are looking at.
BUT, screw from the opposite side

The Line

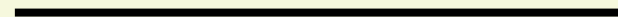

Place the batten on the opposite face of the panel.
Screw from the side you're looking at.
In this case, screw through the panel first and into the batten

6

Repeat for B2, B3, B4, B5, B6 and B7

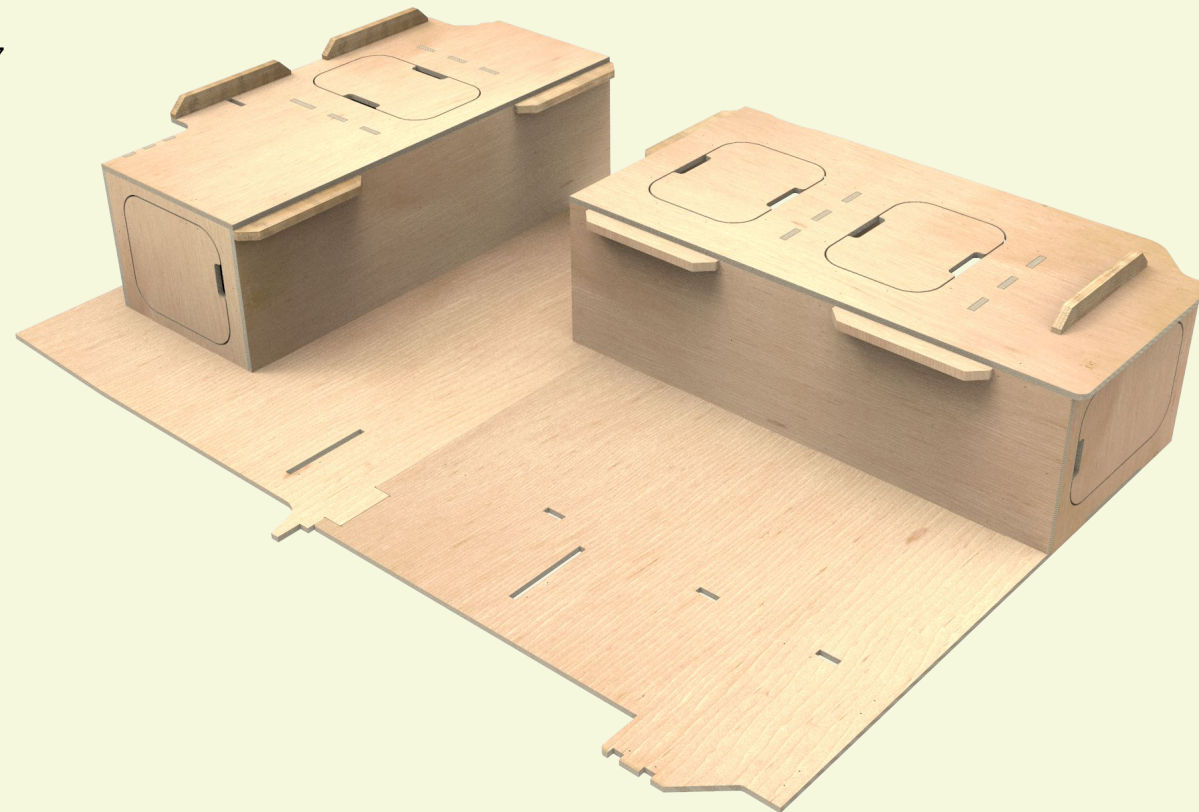

Section B is
completed.

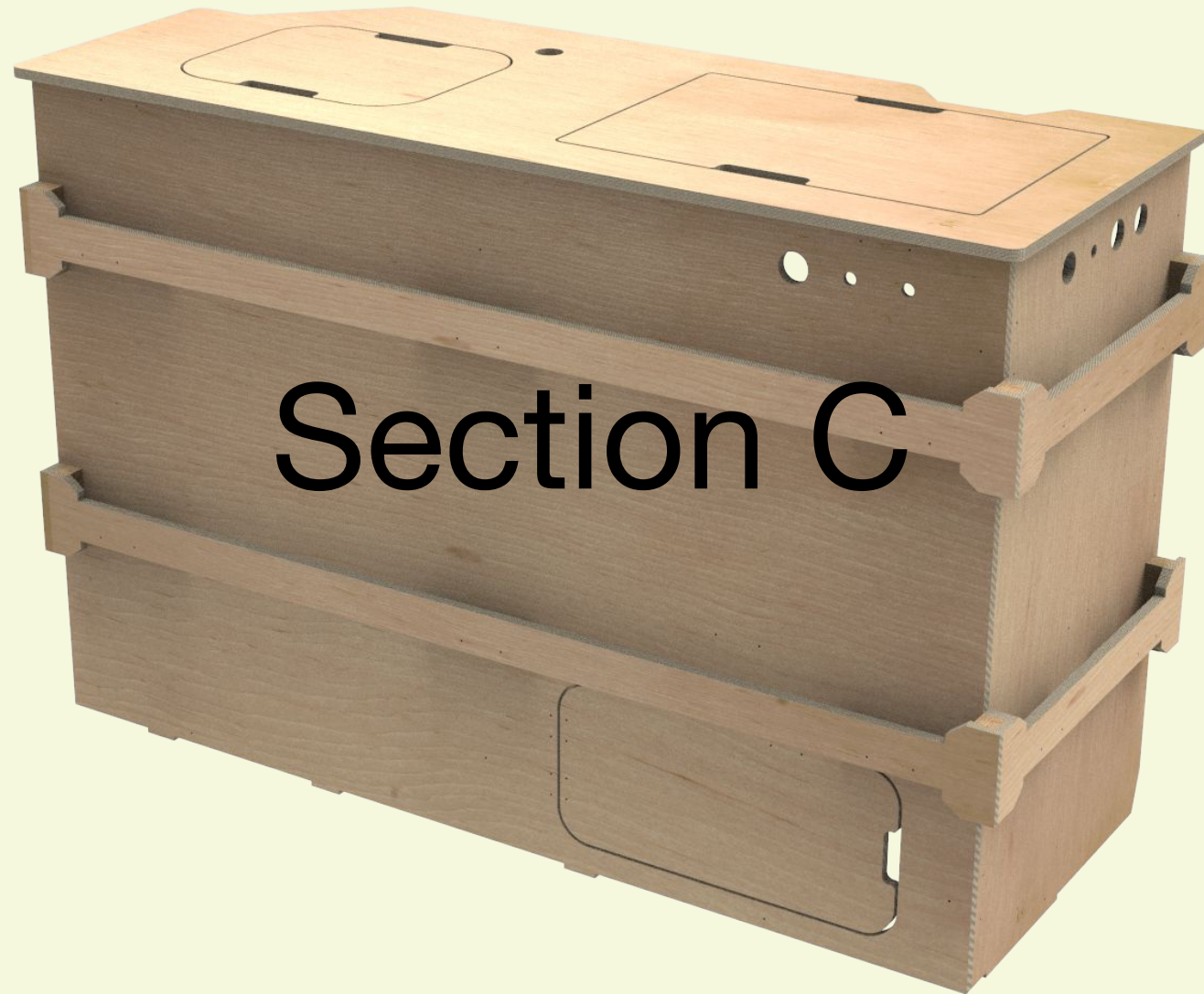

Section C

Section C

1

Screw batten into floor.
Batten location shown by 2 pilot hole 2" apart. There are 5 locations.

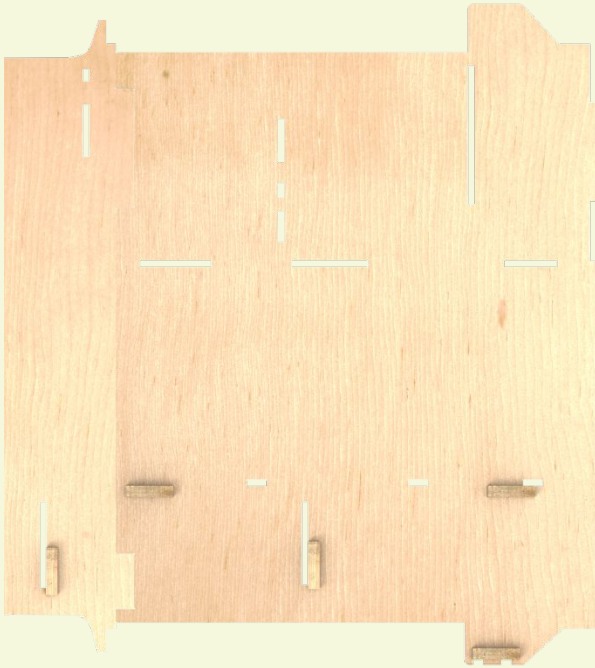

2

Find panel C1 and secure all batten to the panel
Note: C1, C3 & C4 have batten on both sides of the panel

3

Secure C1 to the floor

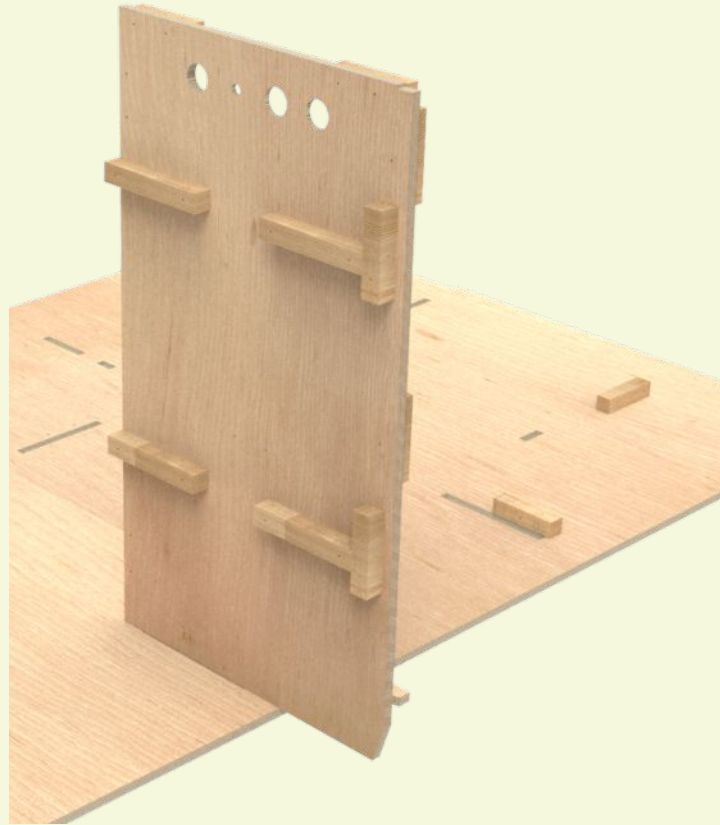

4

Secure C2 to C1 using two pieces of batten.

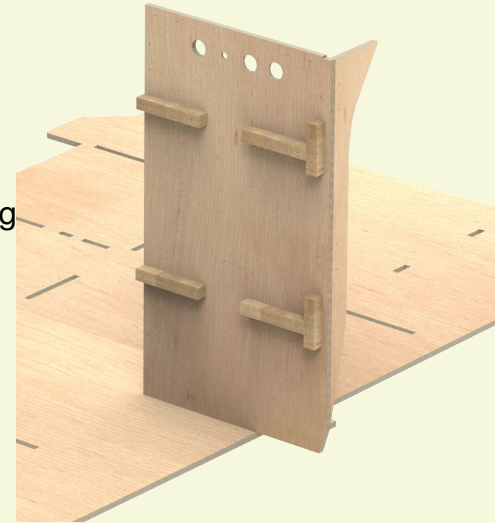

5

Repeat for C3 to C5

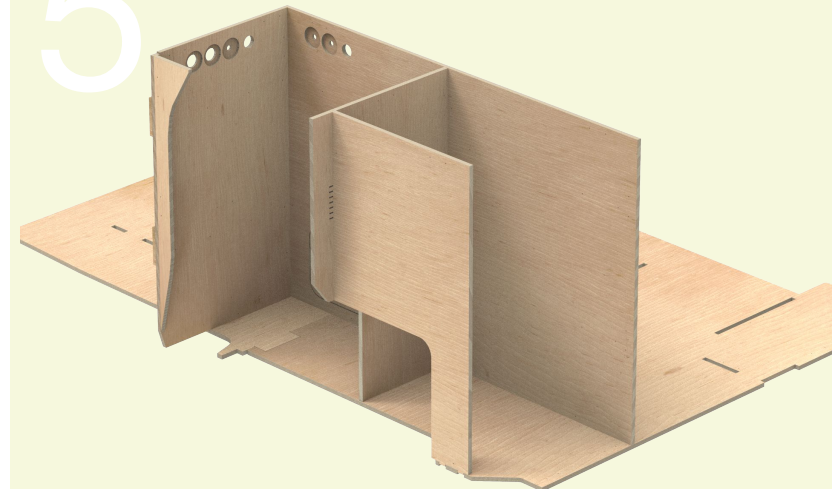

Section C

6

The cabinet shelf (C6) should be secured in place before the worktop is fitted (C7).

Shelf is secured with three screws from the top.

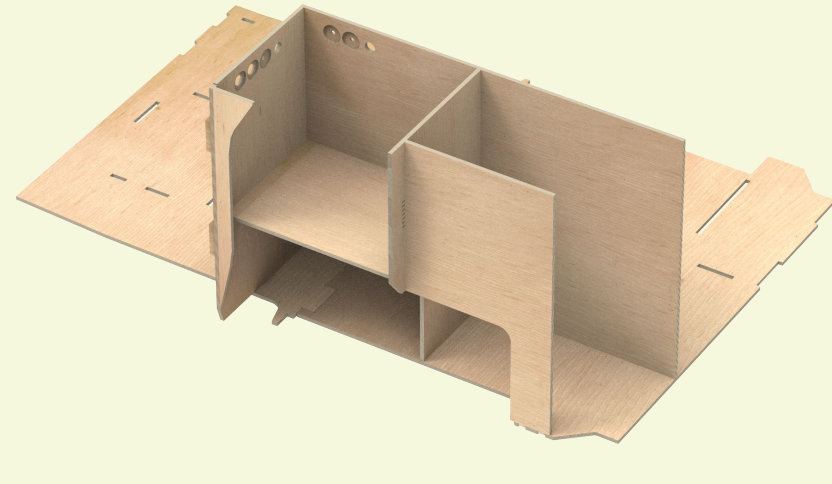

7

Locate the worktop (C7) and the two C shaped pieces.

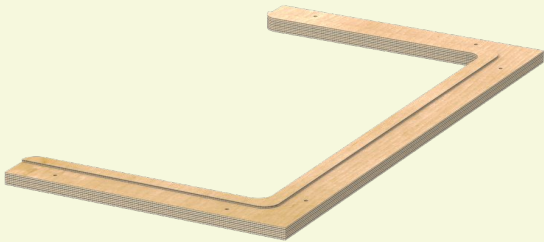

8

Mount the 'C' shaped pieces to the underside of the worktop. The short, raised section on one side will fit into the opening.

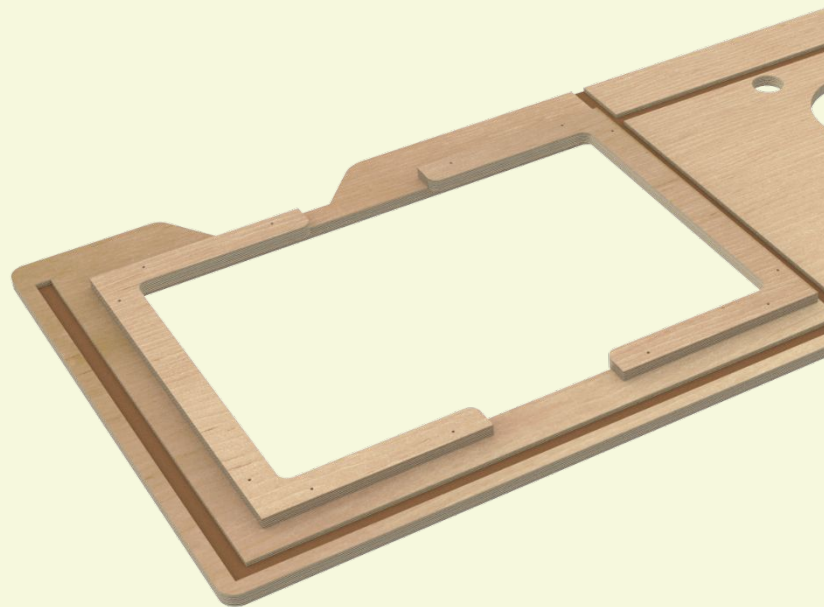

The screws for this part are in a bag labelled 'For Counter Top Trim'

9

The worktop has grooves on the underside that line up with C1, C2, C3, and C4.

- Do not secure the worktop until all panels are sitting in the grooves
- The worktop is secured with 6 screws

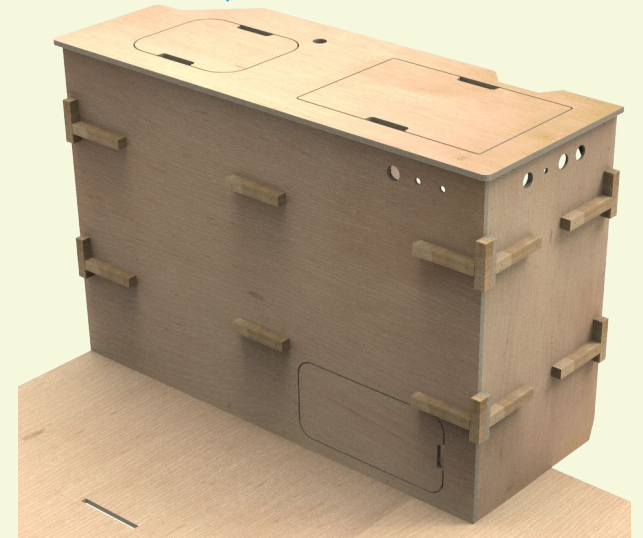

10

Locate the 4 rail pieces.



11

The rails slot in between the batten on the front of Section C from the top and screw into place

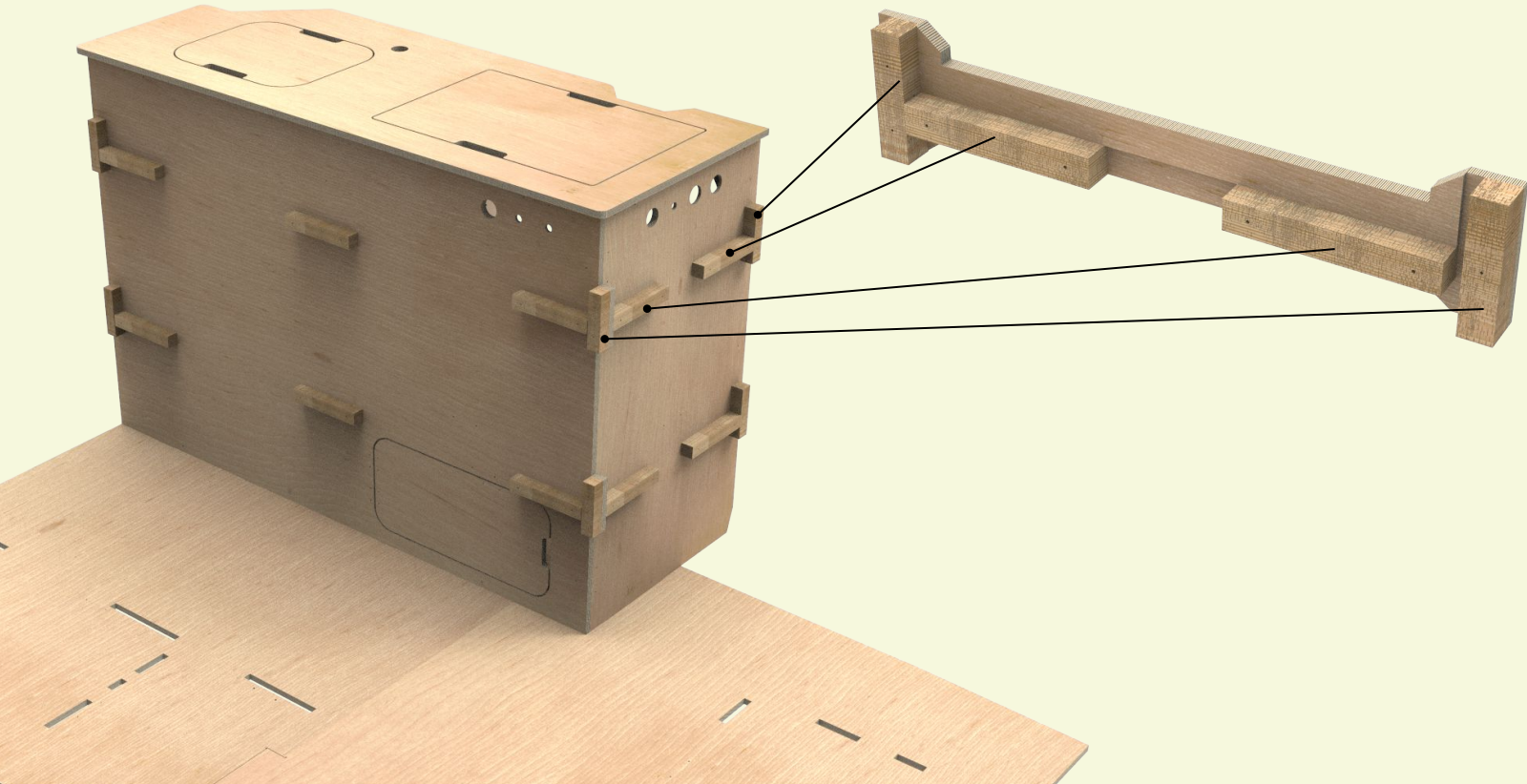

12

Add end caps to rails with one screw

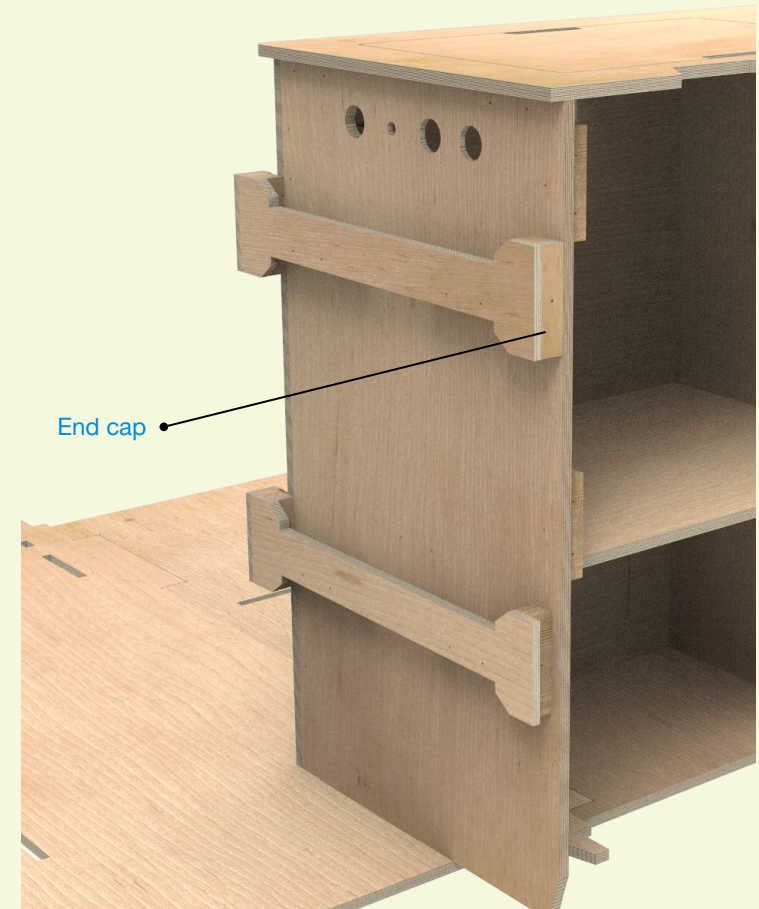

13

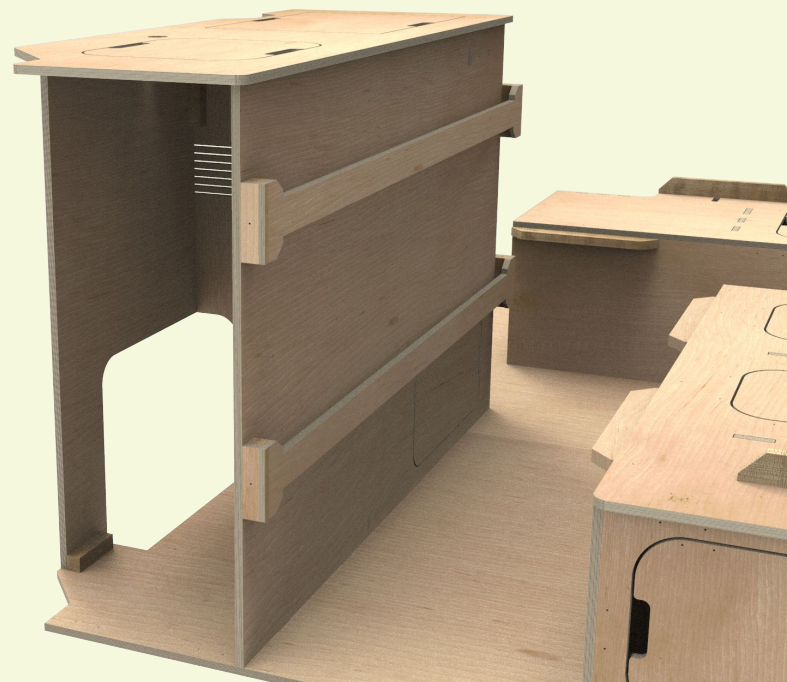

Section C is completed.

Finishing Touches

Hatches

- 1 All 3 hatches use the 6" batten
- 2 Fit 4 pieces of batten around the 4 corners of the hatch using the pilot holes.
- 3 Screw through the panel into the batten
- 4 Drop hatch into place
- 5 Repeat for all 3 hatches

Hatches finished.

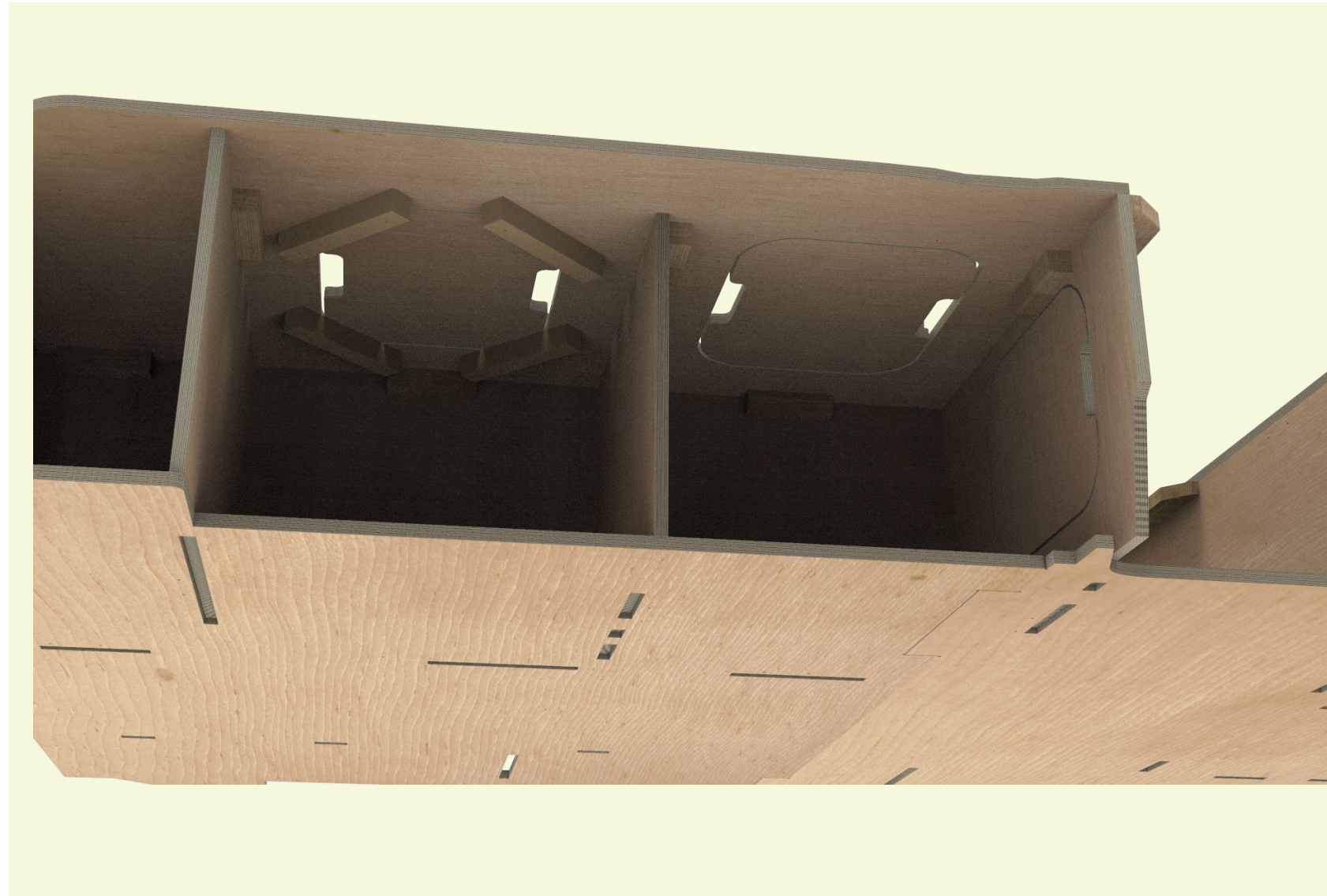

Door magnets

- 1 4 Door magnets and magnet plates are to be installed with the 0.5" Philips head screws
- 2 Fit the metallic plate to each door using pre-drilled pilot holes
- 3 Fit the white magnet catch to the matching surface.
 - On ALL doors the magnet catch needs to be screwed into the batten behind the panel that lines up with the plate on the door.

Magnets finished!

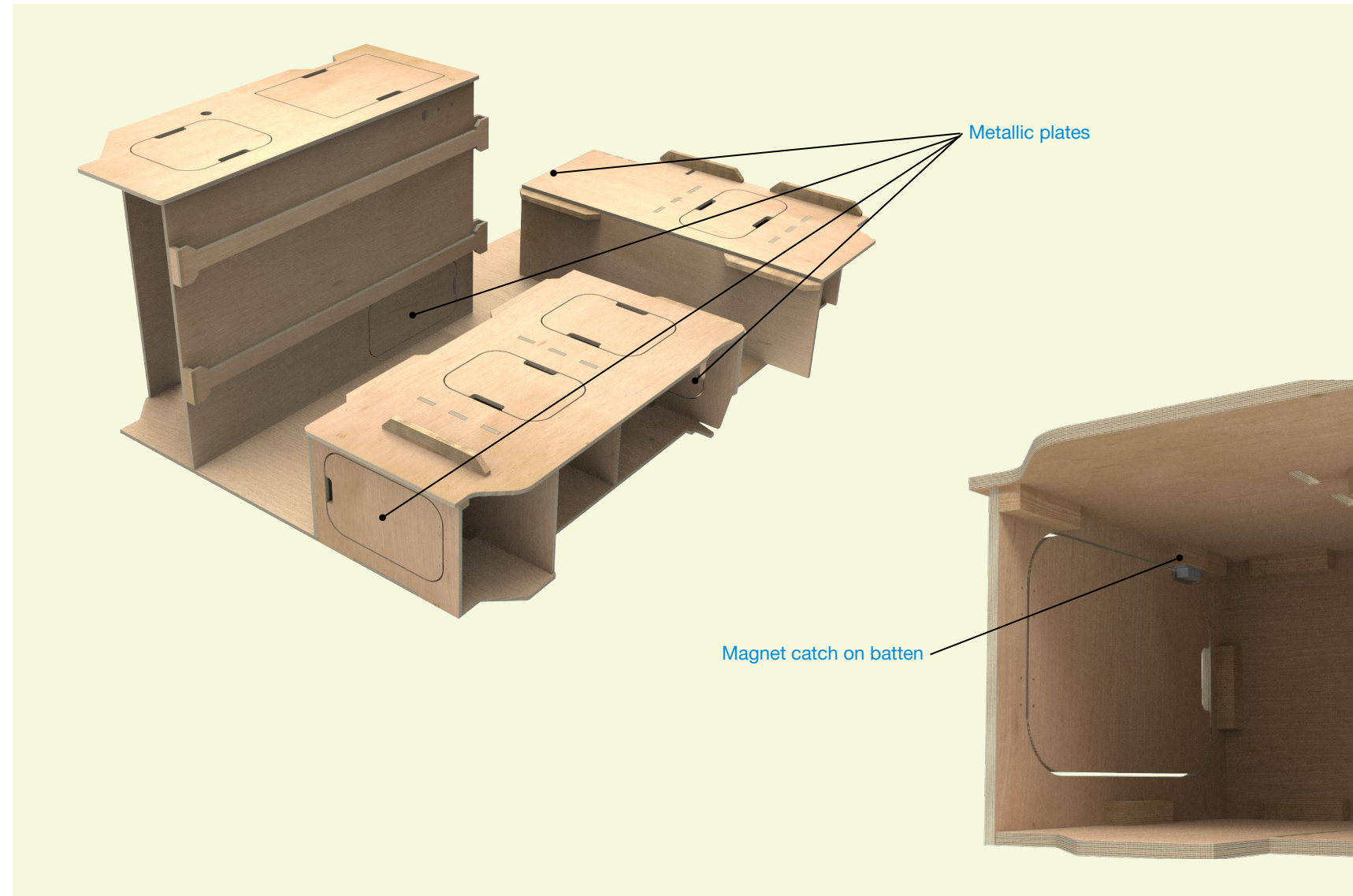

Door hinges

- 1 All 8 door hinges are to be installed with the 0.5" Philips head screws.
- 2 Fit hinges to pilot holes on doors and panels

Door hinges are finished.

Magnets are finished.

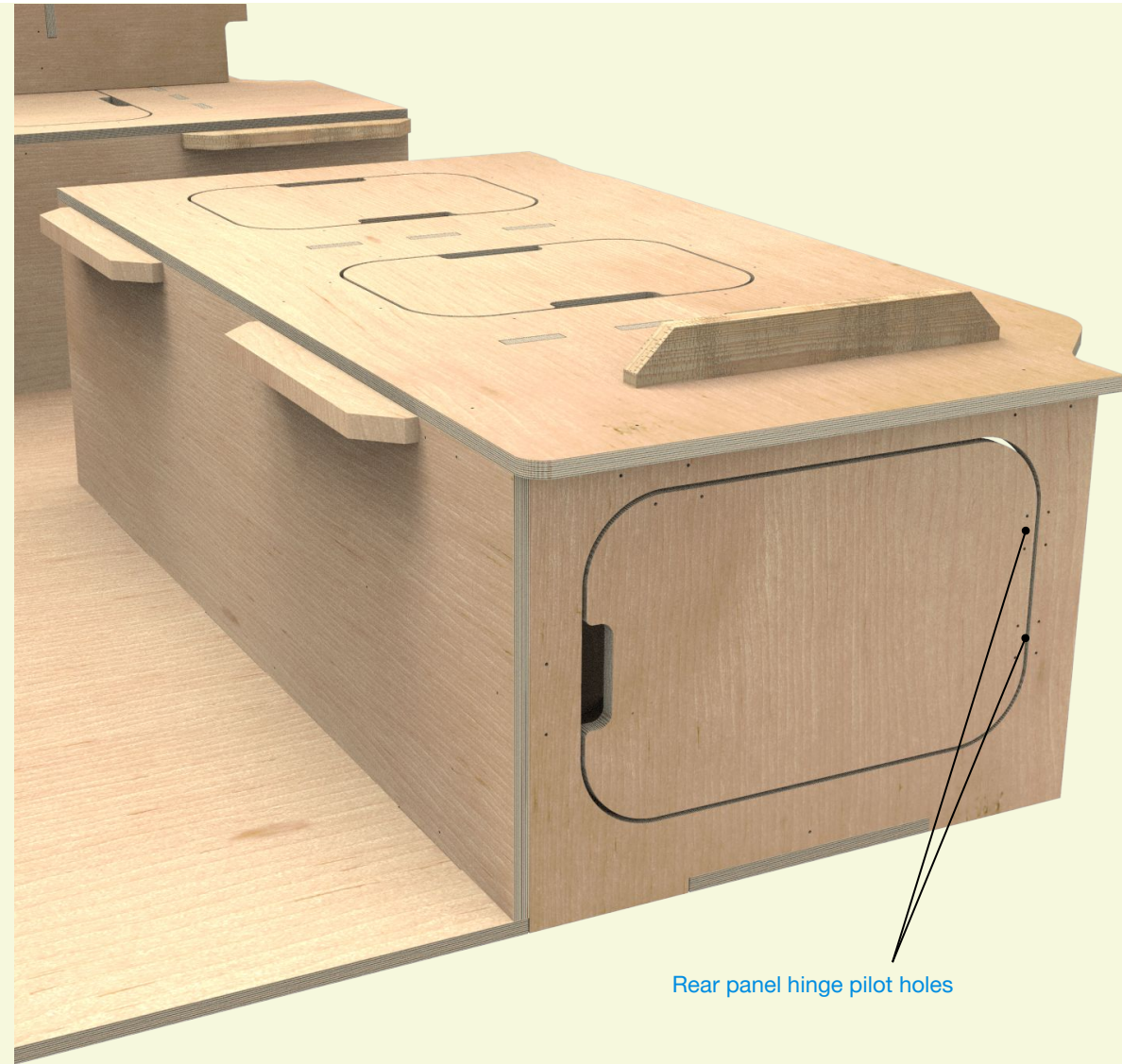

Rear panel hinge pilot holes

Finishing Touches

Back rest

- 1 The back rest is made from panels A7 through A9
- 2 Fit the 4" batten to the pilot holes in A7.
Note: Symbols indicate direction of screw
- 3 Slot A8 and A9 into A7.
- 4 Attach A8 and A9 to the batten by screwing through the panels first and then into the batten.
- 5 When assembled, A8 slots into the bench top (A6).

Backrest is finished.

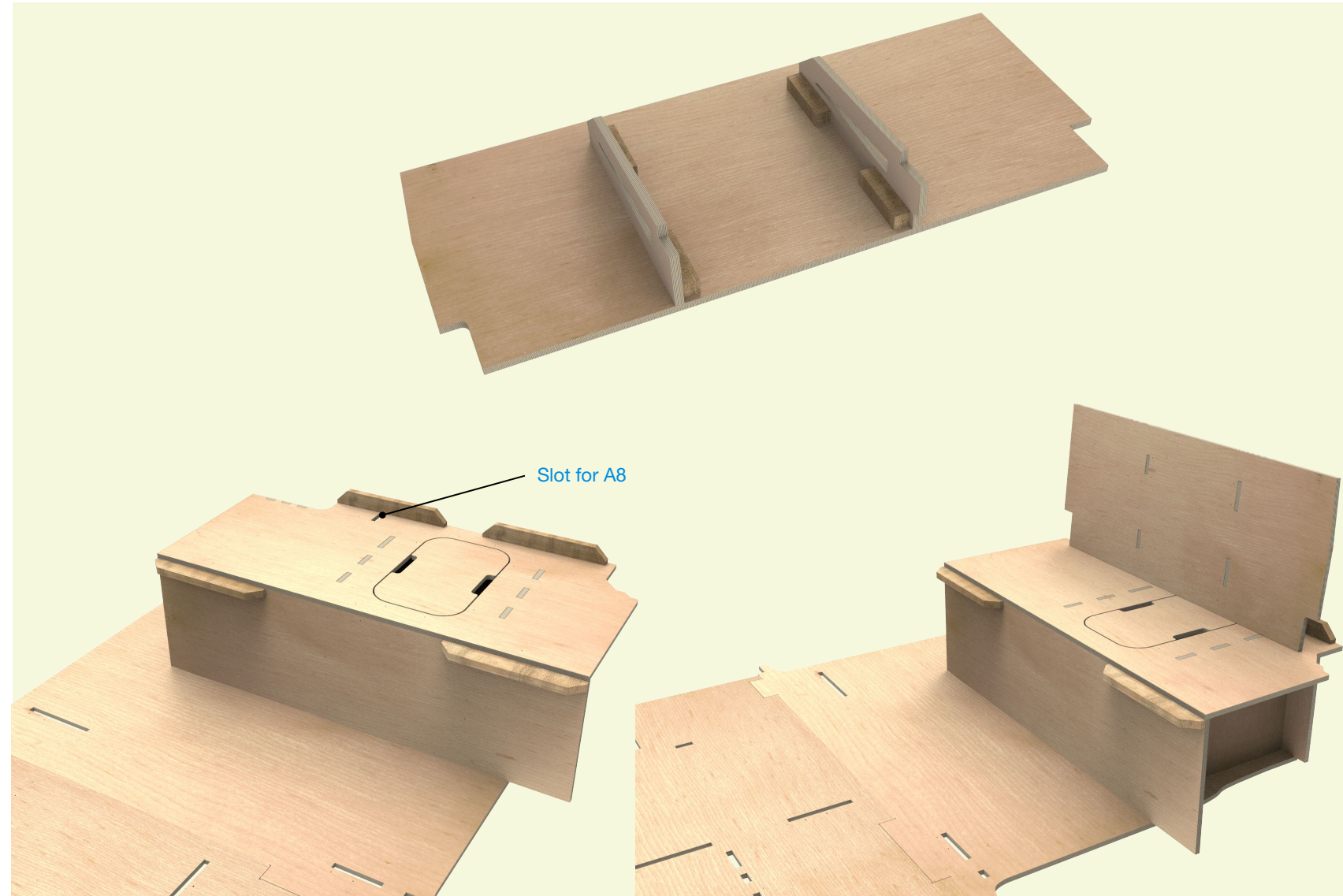

Tables

- 1 The two tables are made up of the table-top and two support arms.
- 2 Slot the support arms into the table.
- 3 Attach 4" batten on the inside of the arms
- 4 Attach the table to the arm by adding a screw from the batten into the top.
- 5 Place the table on the rails by using the hook on the arms.

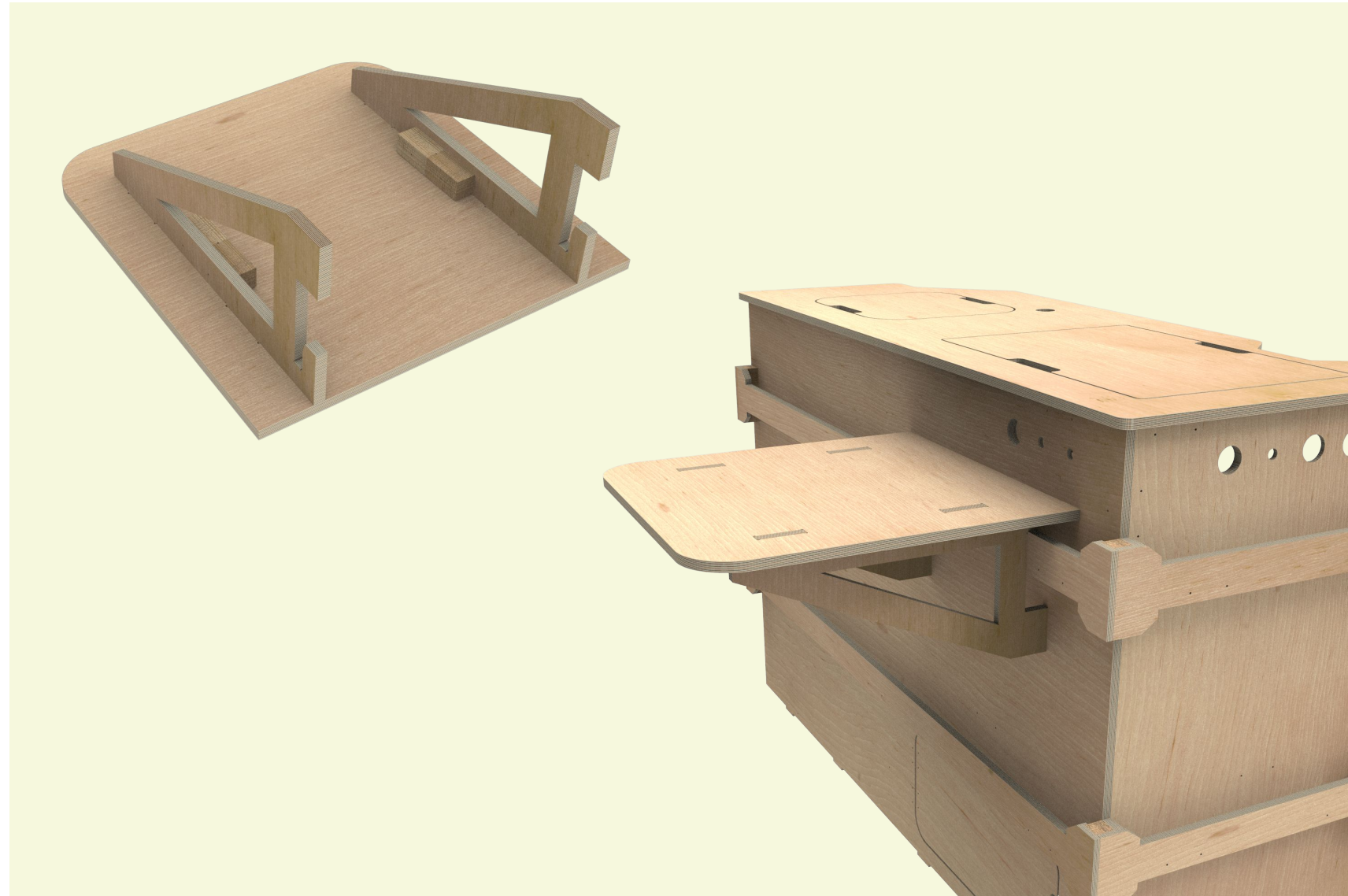

Tables - cont.

6 Repeat for the second table.

Tables are finished.

The tables can be placed anywhere on the rails. Have fun finding the placements that work best for you!

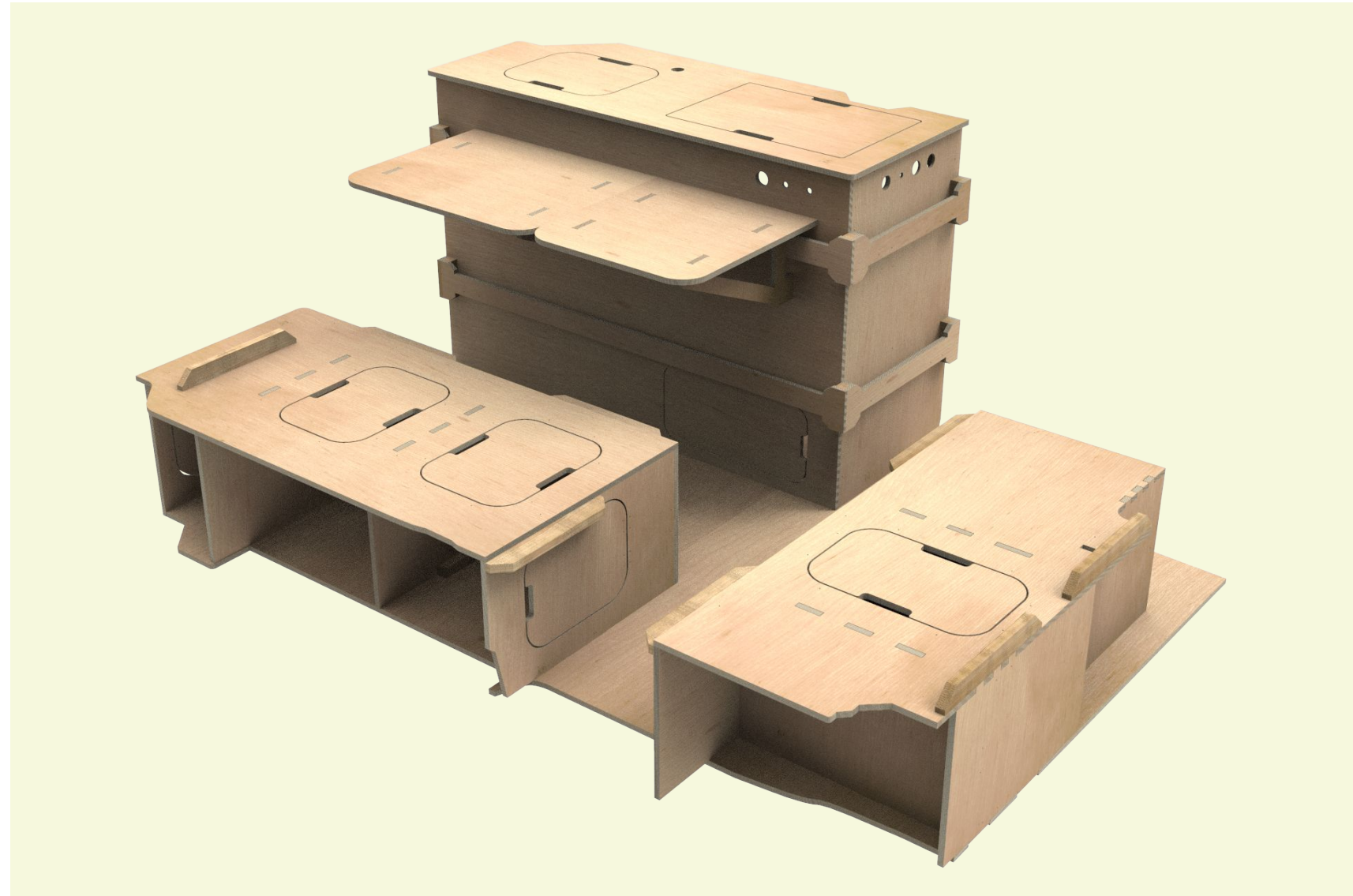

Rear panel

- 1 The rear panel is attached by 2 magnets and 2 hinges.
- 2 Find the panel with the VanLab logo.
- 3 Attach 1 magnet plate and hinge to the panel.
- 4 Attach 2 magnet catches to the holes on opposite side of the hinges.
- 5 Rear panel is finished.

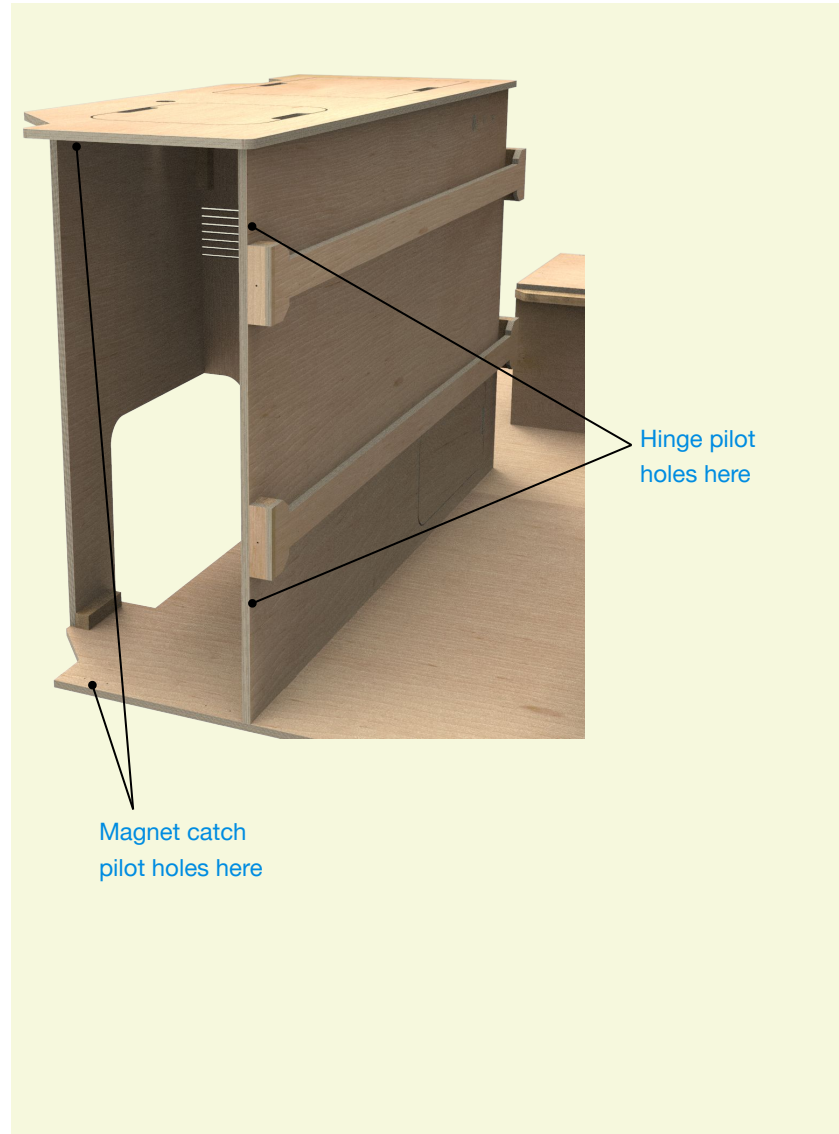

Seating mode

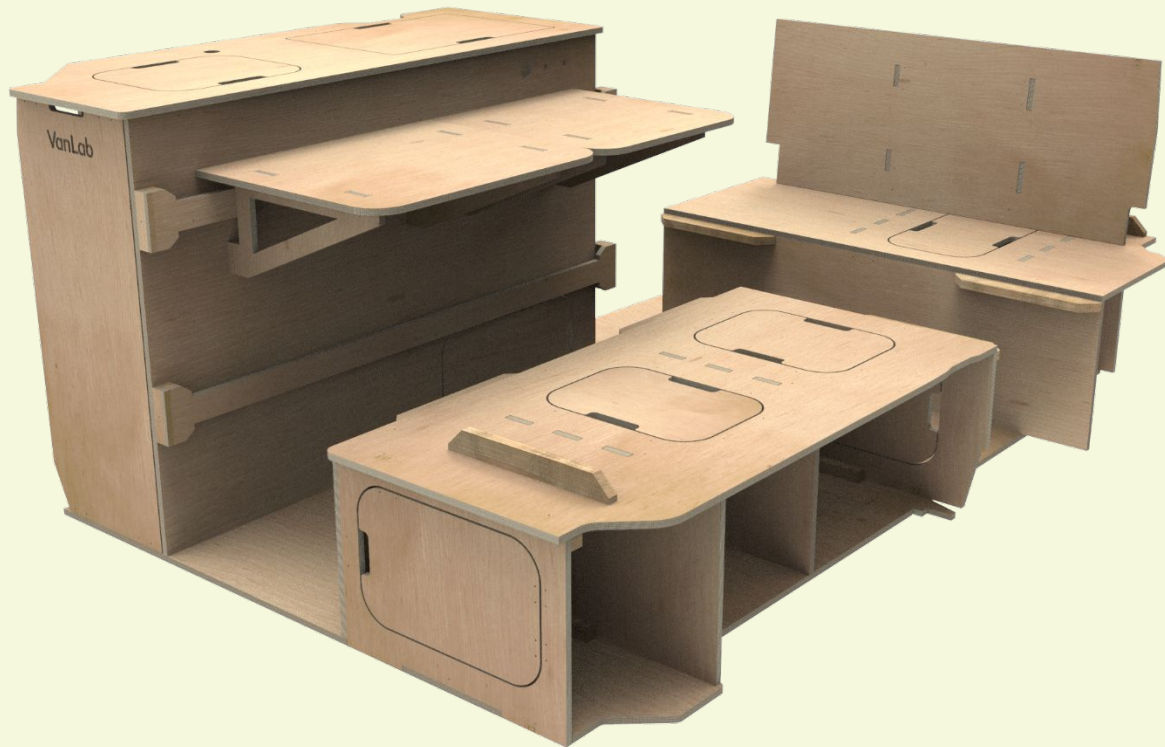

Bed mode



For more information email
info@wearevanlab.com