

DVDO



DVDO-Xtend-Pair150 HDMI 150m Extender with Loopout

Thank you for purchasing the DVDO-Xtend-Pair150

For optimum performance and safety, please read these instructions carefully before connecting, operating or adjusting this product. Please keep this manual for future reference.

Surge protection device recommended.

This product contains sensitive electrical components that may be damaged by electrical spikes, surges, electric shock, lighting strikes, etc. Use of surge protection systems is highly recommended in order to protect and extend the life of your equipment.

Table of Contents

| | |
|--|---|
| 1. Introduction..... | 1 |
| 2. Features..... | 1 |
| 3. Package Contents..... | 2 |
| 4. Specifications..... | 2 |
| 5. Operation Controls and Functions..... | 4 |
| 5.1 Transmitter Panel..... | 4 |
| 5.2 Receiver Panel..... | 5 |
| 5.3 IR Pin Definition..... | 6 |
| 6. Application Example..... | 8 |

1. Introduction

This 18Gbps HDMI Extender can extend high definition video / audio signal, RS-232, bi-directional IR, and the distance is up to 492ft / 150 meters between transmitter and receiver via a single CAT cable. It supports resolution up to 4K2K@60Hz 4:4:4, 18Gbps and HDCP 2.2. One HDMI loop port is available for output. The extender also supports de-embedded audio for L/R audio output. In addition, the extender is equipped with two-way IR pass-through which allows for source and display control.

This HDMI extender includes two units: transmitter unit and receiver unit. The transmitter unit is responsible for capturing HDMI input signal and carrying the signal via one cost effective Cat5e/6 cable, and transmitting / emitting IR control signals. The receiver unit is responsible for receiving the HDMI signal and transmitting / emitting IR control signal.

The extender offers the most convenient solution for HDMI extension via a single Cat5e/6 with long distance capability, and is the perfect solution for any application.

2. Features

- ☆ HDCP 2.2 / HDCP 1.4 and DVI 1.0 compliant
- ☆ Support 18Gbps video bandwidth
- ☆ The maximum extended transmission distance via a single Cat5e/6 cable:
394ft / 120 meters for 4K2K signal;
492ft / 150 meters for 1080P signal
- ☆ Support one HDMI loop output on the transmitter
- ☆ Extract audio to analog stereo output on receiver
- ☆ With bi-directional IR, RS-232 and CEC pass-through
- ☆ HDR, HDR10+, Dolby Vision and HLG function supported
- ☆ Support PoC (Power over Cable) function
- ☆ Compact design for easy and flexible installation

3. Package Contents

| Qty | Item |
|-----|---|
| 1 | 18Gbps HDMI over HDBaseT Extender (Transmitter) |
| 1 | 18Gbps HDMI over HDBaseT Extender (Receiver) |
| 1 | IR Blaster cable (1.5 meters) |
| 1 | 20~60KHz IR Receiver cable (1.5 meters) |
| 4 | Mounting Ear |
| 2 | 3-pin Phoenix connector |
| 1 | 24V/1A Locking Power adapter |
| 1 | User Manual |

4. Specifications

| Technical | |
|--------------------|---|
| HDCP Compliance | HDCP 2.2 / HDCP 1.4 |
| Video Bandwidth | 18Gbps |
| Video Resolution | 4K2K 50/60Hz 4:4:4 4K2K 50/60Hz 4:2:2 4K2K 50/60Hz 4:2:0 4K2K 30Hz 4:4:4 1080p, 1080i, 720p, 720i, 480p, 480i All HDMI 3D TV formats All PC resolutions including 1920 x 1200 |
| Color Space | RGB / YCbCr 4:4:4, YCbCr 4:2:2, YCbCr 4:2:0 |
| Color Depth | 8/10/12-bit (1080P60Hz, 4K30Hz, 4K60Hz YCbCr 4:2:2/4:2:0) 8-bit (4K60Hz 4:4:4) |
| HDMI Audio Formats | LPCM 2.0/2.1/5.1/6.1/7.1, Dolby Digital, Dolby TrueHD, Dolby Digital Plus(DD+), DTS-ES, DTS HD Master, DTS HD-HRA, DTS-X |
| L/R Audio Formats | PCM 2.0 |
| ESD Protection | Human body model — ±8kV (Air-gap discharge) & ±4kV (Contact discharge) |

| Connection | | | |
|---|---|----------------------|-------------------------|
| Transmitter | Inputs: 1x HDMI Type A [19-pin female] Outputs: 1x HDMI Type A [19-pin female] 1x HDBT OUT [RJ45, 8-pin female] Control: 1x IR IN [3.5mm Stereo Mini-jack] 1x IR OUT [3.5mm Stereo Mini-jack] 1x RS-232 [Phoenix jack] 1x SERVICE [Mini-USB, Update port] | | |
| Receiver | Inputs: 1x HDBT IN [RJ45, 8-pin female] Outputs: 1x HDMI Type A [19-pin female] 1x AUDIO OUT [3.5mm Stereo Mini-jack] Control: 1x IR IN [3.5mm Stereo Mini-jack] 1x IR OUT [3.5mm Stereo Mini-jack] 1x RS-232 [Phoenix jack] 1x SERVICE [Mini-USB, Update port] | | |
| Mechanical | | | |
| Housing | Metal Enclosure | | |
| Color | Black | | |
| Dimensions | Transmitter / Receiver: 140mm [W] x 65mm [D] x 18mm [H] | | |
| Weight | Transmitter: 160g, Receiver: 155g | | |
| Power Supply | Input: AC 100 - 240V 50/60Hz Output: DC 24V/1A (Locking connector) | | |
| Power Consumption | 9.36 W | | |
| Operating Temperature | 32 - 104°F / 0 - 40°C | | |
| Storage Temperature | -4 - 140°F / -20 - 60°C | | |
| Relative Humidity | 20 - 90% RH (no condensation) | | |
| Resolution / Distance | | | |
| 4K2K | 394ft / 120M | | |
| 1080P | 492ft / 150M | | |
| Resolution / Cable Length | 4K60 - Feet / Meters | 4K30 - Feet / Meters | 1080P60 - Feet / Meters |
| HDMI IN / OUT | 16ft / 5M | 32ft / 10M | 50ft / 15M |
| The use of "Premium High Speed HDMI" cable is highly recommended. | | | |

5. Operation Controls and Functions

5.1 Transmitter Panel

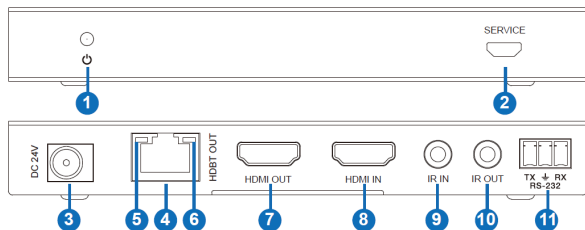

| No. | Name | Function Description |
|-----|----------------------------------|---|
| 1 | Power LED | Red LED indicates that the transmitter is powered on. |
| 2 | SERVICE port | Firmware update port. |
| 3 | DC 24V | DC 24V/1A power supply input port. <i>Note that the extender supports PoC function, it means that either transmitter or receiver is powered on by 24V/1A power adapter, the other one doesn't need power supply.</i> |
| 4 | HDBT OUT | RJ45 connector for connecting the HDBT IN port of receiver with a CAT 5e/6 cable. |
| 5 | Connection Signal Indicator lamp | <ul style="list-style-type: none">▪ Illuminating: Transmitter and Receiver are in good connection status.▪ Flashing: Transmitter and Receiver are in poor connection status.▪ Dark: Transmitter and Receiver are not connected. |
| 6 | Data Signal Indicator lamp | <ul style="list-style-type: none">▪ Illuminating: HDMI signal with HDCP.▪ Flashing: HDMI signal without HDCP.▪ Dark: No HDMI signal. |
| 7 | HDMI OUT | HDMI loop output for display. |
| 8 | HDMI IN | HDMI source input. |
| 9 | IR IN | IR input port for receiving the signal of IR remote. |
| 10 | IR OUT | IR output port for control of source device. This IR output signal is from the IR IN port of receiver. |

| | | |
|----|--------|---|
| 11 | RS-232 | 3-pin Phoenix connector for RS-232 command transmission. The RS-232 command will pass-through from transmitter to receiver or from receiver to transmitter. |
|----|--------|---|

5.2 Receiver Panel

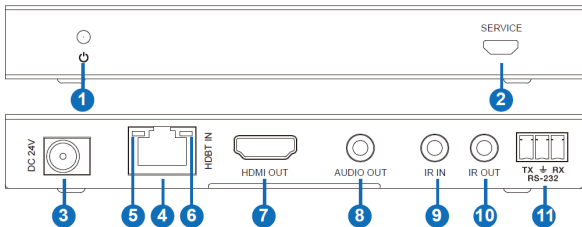

| No. | Name | Function Description |
|-----|----------------------------------|---|
| 1 | Power LED | Red LED indicates that the receiver is powered on. |
| 2 | SERVICE port | Firmware update port. |
| 3 | DC 24V | DC 24V/1A power supply input port. <i>Note that the extender supports PoC function, it means that either transmitter or receiver is powered on by 24V/1A power adapter, the other one doesn't need power supply.</i> |
| 4 | HDBT IN | RJ45 connector for connecting the HDBT OUT port of transmitter with a CAT 5e/6 cable. |
| 5 | Connection Signal Indicator lamp | <ul style="list-style-type: none"> ▪ Illuminating: Transmitter and Receiver are in good connection status. ▪ Flashing: Transmitter and Receiver are in poor connection status. ▪ Dark: Transmitter and Receiver are not connected. |
| 6 | Data Signal Indicator | <ul style="list-style-type: none"> ▪ Illuminating: HDMI signal with HDCP. ▪ Flashing: HDMI signal without HDCP. ▪ Dark: No HDMI signal. |
| 7 | HDMI OUT | HDMI output for display. |
| 8 | AUDIO OUT | 3.5mm stereo connector for analog audio output. |

| | | |
|----|--------|---|
| 9 | IR IN | IR input port for receiving the signal of IR remote. |
| 10 | IR OUT | IR output port for control of display device. This IR output signal is from the IR IN port of transmitter. |
| 11 | RS-232 | 3-pin Phoenix connector for RS-232 command transmission. The RS-232 command will pass-through from transmitter to receiver or from receiver to transmitter. |

5.3 IR Pin Definition

IR Receiver and Blaster pin's definition is as below:



IR RECEIVER



IR BLASTER

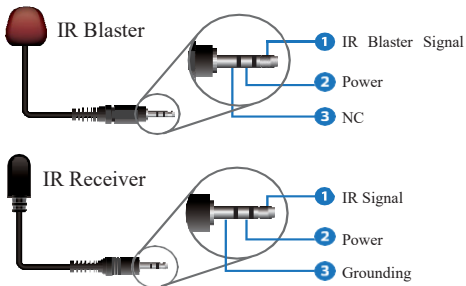

The following is IR system diagram about IR cable use method.

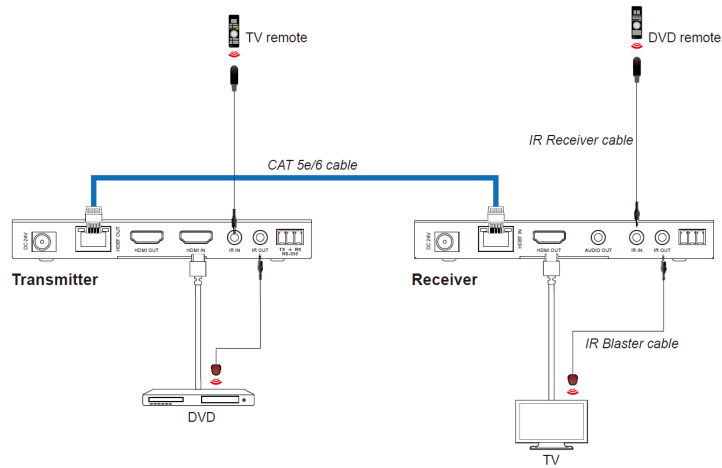

Note: When the angle between the IR receiver and the remote control is $\pm 45^\circ$, the transmission distance is 0-5 meters;

when the angle between the IR receiver and the remote control is $\pm 90^\circ$, the transmission distance is 0-8 meters.

6. Application Example

