

DVDO



DVDO-USBC-HDMI-PS-51

Seamless Switcher / Scaler / Extender
With USB-C & HDMI Inputs & Dante

User Manual

Version v1.0

Thank you for purchasing DVDO-USBC-HDMI-PS-51

For optimum performance and safety, please read these instructions carefully before connecting, operating or adjusting this product. Please keep this manual for future reference.

Surge protection device recommended

DVDO-USCB-HDMI-PS-51 contains sensitive electrical components that may be damaged by electrical spikes, surges, electric shock, lightning strikes, etc. Use of surge protection systems is highly recommended in order to protect and extend the life of your equipment.

Caution

DVDO-USCB-HDMI-PS-51 requires the use of UTP connectors. Please connect in direct interconnection method and do not cross connect.

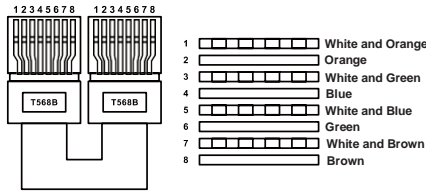

Direct Interconnection Method

Table of Contents

1. Introduction.....	1
2. Features.....	1
3. Package Contents.	1
4. Specifications.	2
5. Operation Controls and Functions.....	4
5.1 Switch Panel.....	4
5.2 HDBaseT Receiver Panel.....	6
5.3 IR Cable Pin Assignment.....	8
6. IR Remote	8
7. Web GUI User Guide	9
8. Dante Web GUI User Guide	18
9. RS-232 Control Commands	21
10. Connection Diagram.	35

1. Introduction

DVDO-USCB-HDMI-PS-51 is a 5x1 seamless presentation switch that includes 3 HDMI inputs, 2 USB-C inputs (DP Alt mode, USB 2.0, 100m Ethernet and 60W charging), 1 HDMI output and 1 HDBT mirrored output. HDBT supports standard PoE power supply and can extend uncompressed signal up to a distance of 230ft/70m (4K@30Hz 4:4:4) or 131ft/40m (4K@60Hz 4:4:4) via a single CAT6A(F/FTP) cable. The output supports either single full screen or various multiview display modes (Single / PIP / PBP / Triple / Quad). DVDO-USCB-HDMI-PS-51 supports USB 2.0 local KVM switching and local Hub/HDBT USB pass-through function (from TX to RX). It also supports bi-directional RS-232 and IR control signal pass-through function. It includes 1 analog audio input, 1 analog audio output, a Dante 2x2 audio input and output and a built-in 3x3 audio matrix with independent audio EQ / volume / delay adjustment.

2. Features

- ☆ HDMI 2.0b, HDCP 2.2 and DP 1.2 compliant
- ☆ Support 18Gbps video bandwidth
- ☆ Support video resolution up to 4K@60Hz 4:4:4
- ☆ Uncompressed 4K60 over HDBT 3.0 up to 132ft/40m via single CAT6A (F/FTP) cable
- ☆ Uncompressed 1080p & 4K30 over HDBT 3.0 up to 230ft/70m via single CAT6A (F/FTP) cable
- ☆ Up to 5 categories of multiview display modes: Single/PIP/PBP/Triple/Quad
- ☆ Support 5x1 seamless switching (single screen) and fast switching (multiview) function
- ☆ Input: 2x USB-C, 3x HDMI, 1x Analog audio, 1x Dante 2ch
- ☆ Output: 1x HDMI and 1x HDBT mirrored, 1x Analog audio, 1x Dante 2ch
- ☆ HDMI and HDBaseT (PoE) outputs (Mirrored)
- ☆ Dante 2x2 audio input and output
- ☆ USB-C supports DisplayPort Alt mode for A/V, USB 2.0, 100M Ethernet and 60W charging
- ☆ Local USB 2.0 KVM switching and extending USB 2.0 over HDBT 3.0
- ☆ Signal input supports manual switching and automatic switching modes
- ☆ Support analog/Dante audio embedding, analog/Dante audio de-embedding output
- ☆ CEC/RS-232 control external devices ON/OFF
- ☆ Advanced EDID management
- ☆ Flexible control via front panel buttons, IR remote, RS-232, TCP/IP or Web GUI
- ☆ Support standard PoE power supply (TX_PSE, RX_PD)

3. Package Contents

- ① 1 x 5x1 Seamless Presentation Switch
- ② 1 x HDBaseT Receiver
- ③ 1 x IR Blaster Cable (1.5 meters)
- ④ 1 x IR Wideband Receiver Cable (1.5 meters)
- ⑤ 2 x 3pin-3.5mm Phoenix Connector (male)
- ⑥ 3 x 5pin-3.5mm Phoenix Connector (male)
- ⑦ 4 x Mounting Ear
- ⑧ 8 x Machine Screw
- ⑨ 1 x 24V/8A Desktop Power Supply & 1 x AC Power Cord (1.5 meters)
- ⑩ 1 x IR Remote
- ⑪ 1 x User Manual

4. Specifications

Technical	
HDMI Compliance	HDMI 2.0b
HDCP Compliance	HDCP 2.2
DP Version	DP 1.2
Video Bandwidth	18Gbps
USB Bandwidth	TX USB DEVICES to TX HOST/USB-C: 480Mbps RX USB DEVICES to TX HOST/USB-C: 350Mbps RX USB DEVICES to RX HOST: 480Mbps
Network Bandwidth (LAN and USB-C Connection)	100Mbps
Input Video Resolution	480i ~1080p50/60Hz, 4Kx2K@24/30Hz, 4K2K@50Hz/ 60Hz 4:4:4
Output Video Resolution	Auto, 3840x2160p60, 3840x2160p50, 4096x2160p60, 4096x2160p50, 3840x2160p30, 3840x2160p25, 1920x 1200p60RB, 1920x1080p60, 1920x1080p50, 1360x768p60, 1280x800p60, 1280x720p60, 1280x720p50, 1024x768p60
IR Level	12Vp-p
IR Frequency	Wideband 20K-60KHz
Color Space	Input: 8/10/12-bit, 8-bit (4K60Hz 4:4:4) Output: 8-bit
Color Depth	RGB, YCbCr 4:4:4 / 4:2:2, YUV 4:2:0
Audio Formats	LPCM 2.0
Audio Sample Rate	48KHz
Transmission Distance	1080p & 4K30 -- 230ft/70m; 4K60 -- 131ft/40m
HDR	Input supports HDR, output does not support HDR.
ESD Protection	Human-body Model: ±8kV (Air-gap discharge) , ±4kV (Contact discharge)
TX Analog Audio	
Input Impedance	10K Ohms
Output Impedance	330 Ohms
Line Input Level (Maximum)	8.2dBu (2Vrms) @ balanced or unbalanced audio
Line Output Level (Maximum)	8.2dBu (2Vrms) @ balanced audio 2.2dBu (1Vrms) @ unbalanced audio
Frequency Response	(+0.5 dB, -1 dB) 20 Hz to 20 kHz
Audio Output Sync Delay	0 to 50ms
Audio S/N Ratio	93dB @ 2Vrms, 1kHz A-weighted
Audio THD+N	<0.1% @ 0dBV, 1kHz

RX Analog Audio	
Output Impedance	330 Ohms
Line Output Level (Maximum)	8.2dBu (2Vrms) @ balanced audio 2.2dBu (1Vrms) @ unbalanced audio
Frequency Response	(+0.5 dB, -1 dB) 20 Hz to 20 kHz
Audio Output Sync Delay	0 to 50ms
Audio S/N Ratio	93dB @ 2Vrms, 1kHz A-weighted
Audio THD+N	<0.1% @ 0dBV, 1kHz
Dante Audio	
Audio Formats	LPCM2.0
Sample Rate	44.1, 48, 88.2 and 96KHz at 24 bits
Audio Delay	2ms, 3ms, 4ms, 5ms, 10ms
Network Bandwidth	100Mbps
Connection	
Transmitter	Input: 3 x HDMI INPUT [Type A, 19-pin female] 2 x USB-C [24-pin female] 1 x LINE IN [5pin-3.5mm phoenix connector] 1 x DANTE [RJ45] Output: 1 x HDMI OUTPUT [Type A, 19-pin female] 1 x HDBT OUTPUT [RJ45] 1 x LINE OUT [5pin-3.5mm phoenix connector] Control: 1 x RS-232 [3pin-3.5mm phoenix connector] 1 x LAN [RJ45] 1 x USB HOST [USB Type B] 2 x USB DEVICES [USB Type A] 1 x IR IN [3.5mm stereo mini-jack] 1 x IR OUT [3.5mm stereo mini-jack]
Receiver	Input: 1 x HDMI IN [Type A, 19-pin female] 1 x HDBaseT IN [RJ45] Output: 1 x HDMI OUT [Type A, 19-pin female] 1 x LINE OUT [5pin-5mm phoenix connector] Control: 1 x RS-232 [3pin-3.5mm phoenix connector] 1 x USB HOST [USB Type B] 2 x USB DEVICES [USB Type A] 1 x SERVICE [Micro USB] 1 x IR IN [3.5mm stereo mini-jack] 1 x IR OUT [3.5mm stereo mini-jack]

Mechanical	
Housing	Front panel: Aluminum; Rear case: Metal Enclosure
Color	Black
Dimensions	Transmitter: 220mm [W]×150mm [D]×44mm [H] Receiver: 140mm [W]×105mm [D]×21.5mm [H]
Weight	Transmitter: 1.21Kg; Receiver: 424g
Power Supply	Input: AC100 - 240V 50/60Hz Output: DC 24V/8A (US/EU standard, CE/FCC/UL certified)
Power Consumption	150W (Max)
Operating Temperature	0°C ~ 40°C / 32°F ~ 104°F
Storage Temperature	-20°C ~ 60°C / -4°F ~ 140°F
Relative Humidity	20%~90% RH (non-condensing)

5. Operation Controls and Functions

5.1 Switch Panel

Front Panel

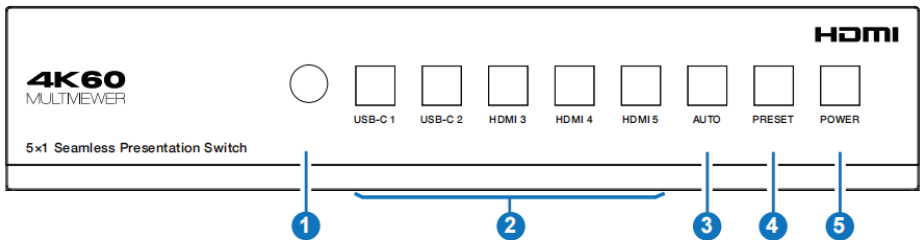

No.	Name	Function Description
1	IR Window	IR signal receiving window, receiving the IR remote signal.
2	USB-C 1 / USB-C 2 / HDMI 3 / HDMI 4 / HDMI 5 buttons	In single screen display mode, press the USB-C 1 / USB-C 2 / HDMI 3 / HDMI 4 / HDMI 5 button to select the signal input channel, and the corresponding button light will be on. In multiview mode, input button lights indicate the outputs, for example, when USB-C 1, HDMI 3 and HDMI 5 port are the signal input channels for triple display mode, the corresponding USB-C 1, HDMI 3 and HDMI 5 button lights will be on. When USB-C 1 port is the shared signal input channel for triple display mode, only the corresponding USB-C 1 button light will be on. It can be set through the Web GUI. Press any input button will switch back to the single screen display mode. The button light will turn off automatically after 1 second each time.

No.	Name	Function Description
3	AUTO button	Press this button to enable/disable the auto switching function. When the auto switching function is enabled, the button light will be on.
4	PRESET button	Press this button to cycle through the preset application scenes. The button light will automatically turn off after 1 second each time. The scenes can be preset through the Web GUI.
5	POWER button	Press and hold this button for 3 seconds, the unit will enter standby mode and the button light will be on. In standby mode, short press this button, the unit will be turned on and the button light will be off.

Rear Panel

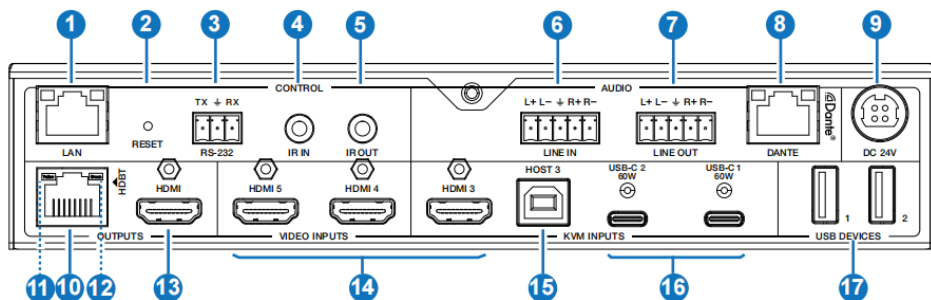

No.	Name	Function Description
1	LAN port	Connect to a router or Switch for USB-C Internet access or Web GUI control.
2	RESET button	Press and hold this button for 5 seconds to restore to factory default settings.
3	RS-232 port	RS-232 serial port, used for RS-232 signal pass-through or controlling the unit via RS-232 commands.
4	IR IN port	Connect the IR receiver cable, used for IR signal pass-through or controlling the unit via the IR remote.
5	IR OUT port	Connect the IR blaster cable, the IR signal is from the IR IN port of the HDBaseT Receiver.
6	LINE IN port	Analog audio input port, supporting balanced/unbalanced audio input, with a maximum support of 2V _{rms} . Balanced connection method: L+, L-, $\frac{1}{2}$, R+, R- Unbalanced connection method: L+, $\frac{1}{2}$, R+

No.	Name	Function Description
7	LINE OUT port	Analog audio output port, supporting balanced audio output (with a maximum support of 2Vrms) and unbalanced audio output (with a maximum support of 1Vrms). Balanced connection method: L+, L-, $\frac{1}{2}$ R+, R- Unbalanced connection method: L+, $\frac{1}{2}$ R+
8	DANTE port	Dante Network port, connected to the Switch with other Dante receivers. This port supports receiving and transmitting signals.
9	DC 24V port	Power port, connected to the DC 24V power adapter.
10	HDBT OUTPUT port	HDBaseT output port, connected to the HDBaseT IN port of the receiver with a CAT6A (F/FTP) cable.
11	Data Signal Indicator (Yellow)	<ul style="list-style-type: none"> Light on: HDMI signal input with HDCP. Light flashing: HDMI signal input without HDCP. Light off: No HDMI signal input.
12	Link Signal Indicator (Green)	<ul style="list-style-type: none"> Light on: Transmitter and Receiver are in good connection status. Light flashing: Transmitter and Receiver are in poor connection status. Light off: Transmitter and Receiver are not connected.
13	HDMI OUTPUT port	HDMI signal output port, connected to HDMI display device such as TV or monitor with HDMI cable.
14	HDMI 3/4/5 VIDEO INPUTS	HDMI signal input ports, connected to HDMI source device such as DVD or Blu-ray player with HDMI cable.
15	HOST 3 port	USB Host port, connected to PC.
16	USB-C 1/2 ports	USB-C signal input port, connected to USB-C signal source device, with the function of 60W charging.
17	USB DEVICES ports	Two USB extension ports, connected to mouse, keyboard, USB camera or other USB devices.

5.2 HDBaseT Receiver Panel

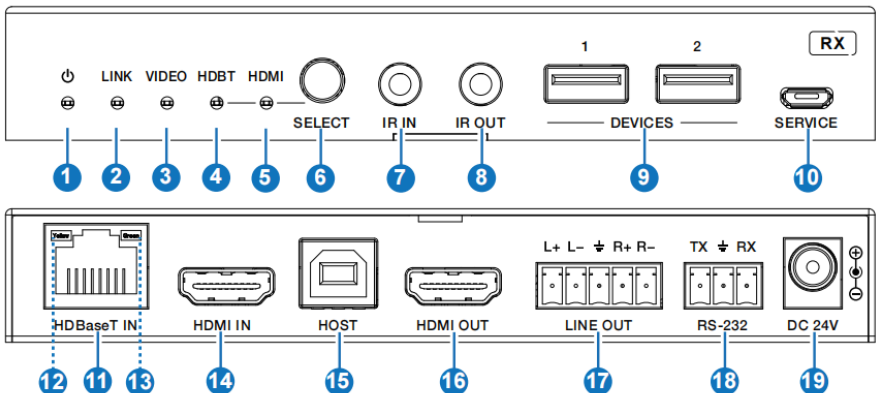

No.	Name	Function Description
1	Power LED	When the receiver is powered on, the red power LED will be on.
2	LINK LED	<ul style="list-style-type: none"> ▪ Light on: Transmitter and Receiver are in good connection status. ▪ Light flashing: Transmitter and Receiver are in poor connection status. ▪ Light off: Transmitter and Receiver are not connected.
3	VIDEO LED	<ul style="list-style-type: none"> ▪ Light on: HDMI signal input with HDCP. ▪ Light flashing: HDMI signal input without HDCP. ▪ Light off: No HDMI signal input.
4	HDBT LED	When the HDBaseT IN port is selected as the signal input channel, the green HDBT LED will be on.
5	HDMI LED	When the HDMI IN port is selected as the signal input channel, the green HDMI LED will be on.
6	SELECT button	Press this button to select signal input channel.
7	IR IN port	Connect the IR receiver cable, the IR signal will be sent to the IR OUT port of the transmitter.
8	IR OUT port	Connect the IR blaster cable, the IR signal is from the IR IN port of the transmitter.
9	DEVICES ports	Two USB extension ports, connected to whiteboard, mouse, keyboard, USB camera or other USB devices.
10	SERVICE port	Firmware update port.
11	HDBaseT IN port	HDBaseT input port, connected to the HDBT OUTPUT port of the transmitter with a CAT6A (F/FTP) cable.
12	Data Signal Indicator (Yellow)	<ul style="list-style-type: none"> ▪ Light on: HDMI signal input with HDCP. ▪ Light flashing: HDMI signal input without HDCP. ▪ Light off: No HDMI signal input.
13	Link Signal Indicator (Green)	<ul style="list-style-type: none"> ▪ Light on: Transmitter and Receiver are in good connection status. ▪ Light flashing: Transmitter and Receiver are in poor connection status. ▪ Light off: Transmitter and Receiver are not connected.
14	HDMI IN port	HDMI signal input port, connected to HDMI source device such as DVD or Blu-ray player with HDMI cable.
15	HOST port	USB Host port, connected to PC.
16	HDMI OUT port	HDMI signal output port, connected to HDMI display device such as TV or monitor with HDMI cable.
17	LINE OUT port	<p>Analog audio output port, supporting balanced audio output (with a maximum support of 2Vrms) and unbalanced audio output (with a maximum support of 1Vrms).</p> <p>Balanced connection method: L+, L-, $\frac{L}{2}$, R+, R-</p> <p>Unbalanced connection method: L+, $\frac{L}{2}$, R+</p>
18	RS-232 port	RS-232 serial port, used for RS-232 signal pass-through or controlling this receiver via RS-232 commands.
19	DC 24V port	<p>Power port, connected to the DC 24V power adapter.</p> <p>Note: The receiver also can be powered by POE (through the HDBaseT IN port).</p>

5.3 IR Cable Pin Assignment

The pin assignment of the IR Receiver cable and IR Blaster cable is as below:

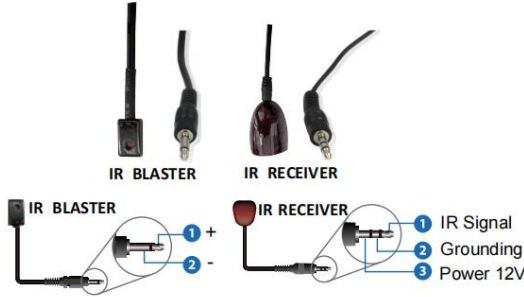

Note: When the angle between the IR receiver and the remote control is $\pm 45^\circ$, the transmission distance is 0-5 meters; when the angle between the IR receiver and the remote control is $\pm 90^\circ$, the transmission distance is 0-8 meters.

6. IR Remote

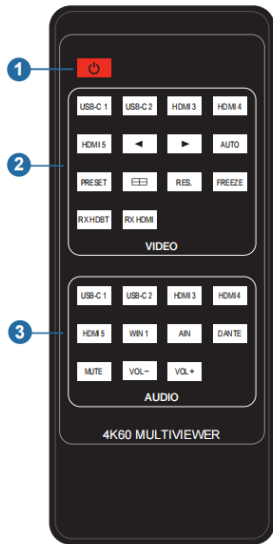

① **Power button:** Press this button to power on the switch or set it to standby mode.

② **VIDEO buttons:**

USB-C 1 / USB-C 2 / HDMI 3 / HDMI 4 / HDMI 5: Press these buttons to select input source in single screen display mode, and the corresponding input button light on the front panel will light in blue.

◀ ▶: Press these buttons to circularly select the last or next input source in single screen display mode.

AUTO: Press this button to enable/disable the auto switching function.

PRESET: Press this button to cycle through the preset application scenes.

⊞: Multiview display mode switching button.

Short press this button to circularly select: Single - PIP - PBP - Triple - Quad.

RES.: Press this button to cycle through the output resolution.

FREEZE: Press this button to freeze/unfreeze the screen.

RX HDBT: Press this button to select the HDBaseT IN port as the signal source input channel of the receiver.

RX HDMI: Press this button to select the HDMI IN port as the signal source input channel of the receiver.

③ **AUDIO buttons:**

USB-C 1 / USB-C 2 / HDMI 3 / HDMI 4 / HDMI 5 / WIN 1 / DANTE: Press these buttons to select the audio input channel for the HDMI/HDBT output.

Note: USB-C 1, USB-C 2, HDMI 3, HDMI 4, HDMI 5 and WIN 1 belongs to the audio input channels of Main In (HDMI/USB-C In).

Mute: Press this button to mute / unmute the audio of Master Out.

VOL-, VOL+: Press these buttons to increase / decrease the audio output volume of Master Out.

7. Web GUI User Guide

The presentation switch can be controlled by Web GUI. The operation method is shown as below:

Step 1: Get the current IP Address.

The default IP address is 192.168.0.100 (when the system is not connected to a router). You can get the current switch IP address via RS-232 command control. Send the ASCII command “r ip addr” through a Serial Command tool, then you'll get the current IP address (The IP address is variable, depending on what the specific machine returns).

For the details of RS-232 control, please refer to “9. RS-232 Control Command”.

Step 2: Connect the LAN port of the presentation switch to a PC with an UTP cable (as shown in the following figure), and set the IP address of the PC to be in the same network segment with the presentation switch.

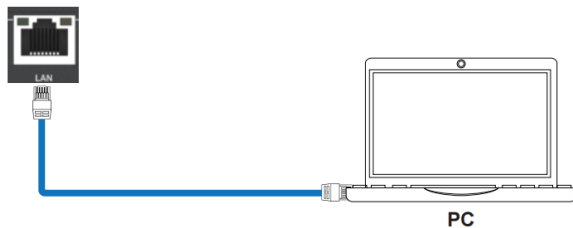

Step 3: Input the current IP address of switch into your browser on the PC to enter Web GUI interface.

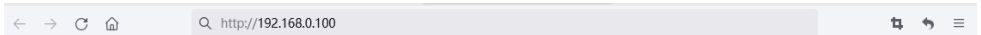

After entering the Web GUI page, there will be a Login interface, as shown below:

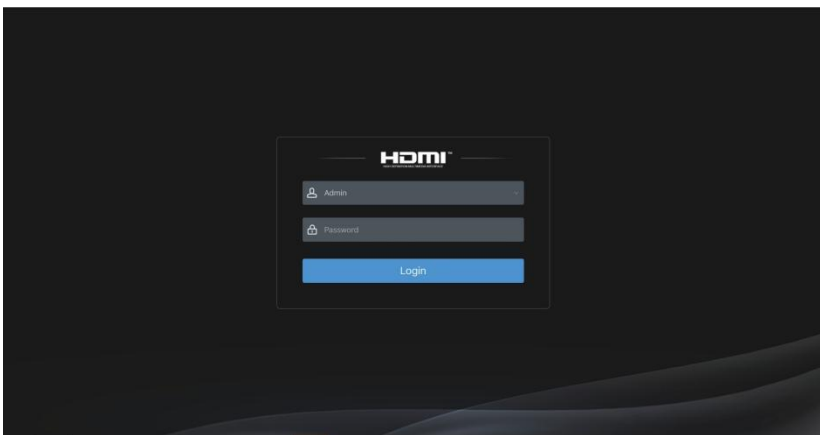

The default usernames and passwords are as below:

Username	User	Admin
Password	user	admin

Select the username “User” and input the password “user”, then click the “Login” button to enter the User page.

■ User Page

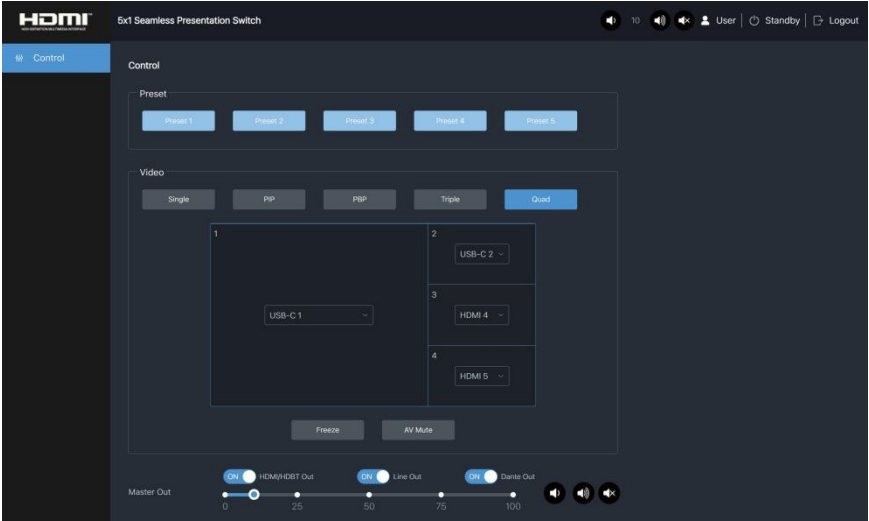

You can do the following operations on the User page:

- ① **Preset:** Recall the preset application scenes.
- ② **Video:** Set the multiview display mode, select input source for each screen, freeze the screen or mute the audio.
- ③ **Master Out:** Set the audio volume or mute/unmute the audio for Master Out. You can respectively turn on/off the HDMI/HDBT Out, Line Out or Dante Out.

In the Login interface, select the username “Admin” and input the password “admin”, then click the “Login” button to enter the Information page of the Admin interface.

■ Information Page

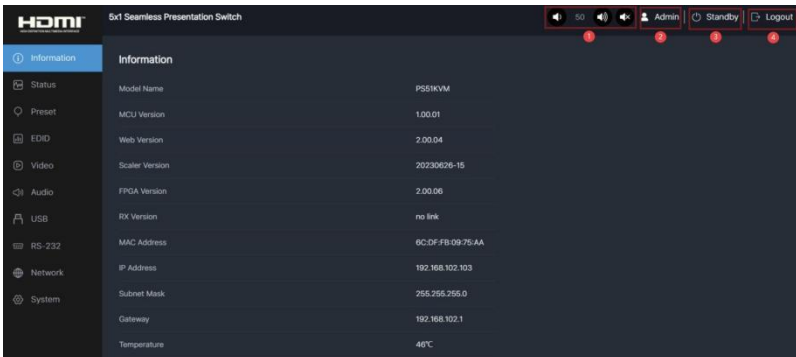

The Information page provides basic information about the model name, software version, IP information and the current machine temperature.

Besides, you can do the following operations on each page of the Admin interface.

- ① Display and set the audio volume of Master Out. Click the volume icons to increase/decrease the audio volume of Master Out, or click the mute icon to mute/unmute the audio of Master Out. When muted, the mute icon displays red.
- ② Display the current username (User or Admin).
- ③ Click the power icon to power on the switch or set it in standby mode.
- ④ Click the logout icon to logout and return to the login interface.

■ Status Page

In/Out	Cable	Resolution	Color Space	Color Depth	HDCP
USB-C 1	Disconnect	None	None	None	None
USB-C 2	Disconnect	None	None	None	None
HDMI 3	Disconnect	None	None	None	None
HDMI 4	Disconnect	None	None	None	None
HDMI 5	Disconnect	None	None	None	None
HDMI Out	Disconnect	None	None	None	None
HDBT Out	Disconnect	None	None	None	None

The Status page displays the input & output port connection status, input & output resolution, Color Space, Color Depth and HDCP.

■ Preset Page

Preset ID	Preset Name	Preset Save	Preset Clear	Preset Recall
1	Preset 1	Save	Clear	Recall
2	Preset 2	Save	Clear	Recall
3	Preset 3	Save	Clear	Recall
4	Preset 4	Save	Clear	Recall
5	Preset 5	Save	Clear	Recall

You can set up to 5 preset scenes on the Preset page.

- ① **Preset Name:** You can name the preset scene. (Chinese name is not supported.)
- ② **Preset Save:** Click the Save button to save the scene.
- ③ **Preset Clear:** Click the Clear button to clear the saved scene.
- ④ **Preset Recall:** Click the Recall button to recall the saved scene.

■ EDID Page

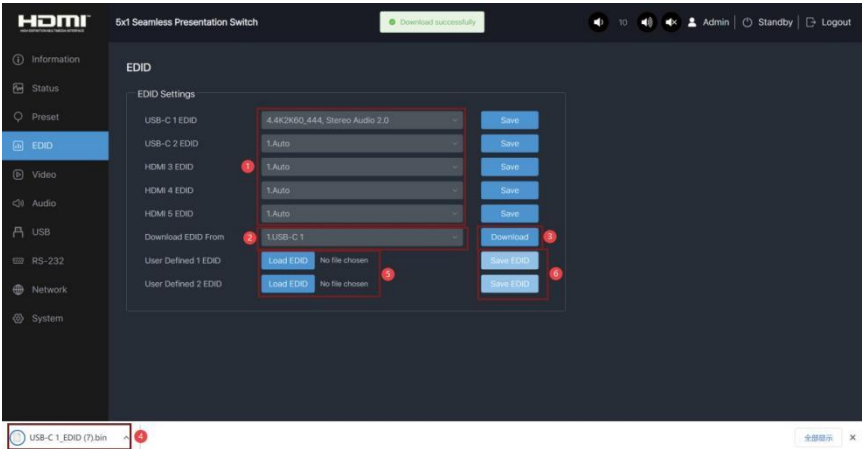

You can do the following operations on the EDID page.

① Click the drop-down list to set EDID for each input port. The EDID list is as below.

No.	EDID Mode	No.	EDID Mode
1	Auto	9	1680x1050, Stereo Audio 2.0
2	Copy HDMI OUT	10	1600x1200, Stereo Audio 2.0
3	Copy HDBT OUT	11	1440x900, Stereo Audio 2.0
4	4K2K60_444, Stereo Audio 2.0	12	1360x768, Stereo Audio 2.0
5	4K2K30_444, Stereo Audio 2.0	13	1280x1024, Stereo Audio 2.0
6	1080p, Stereo Audio 2.0	14	1024x768, Stereo Audio 2.0
7	720p, Stereo Audio 2.0	15	User Defined 1
8	1920x1200, Stereo Audio 2.0	16	User Defined 2

② Click the drop-down list to select USB-C 1\USB-C 2\HDMI 3\HDMI 4\HDMI 5\HDMI OUT\HDBT OUT for EDID download.

③ Click the Download button to download EDID and generate a .bin file.

④ Display the downloaded EDID .bin file.

⑤ Click the Load EDID button to download user-defined EDID. Please note that only .bin files are supported.

⑥ Click the Save EDID button to save the user-defined EDID.

■ Video Page

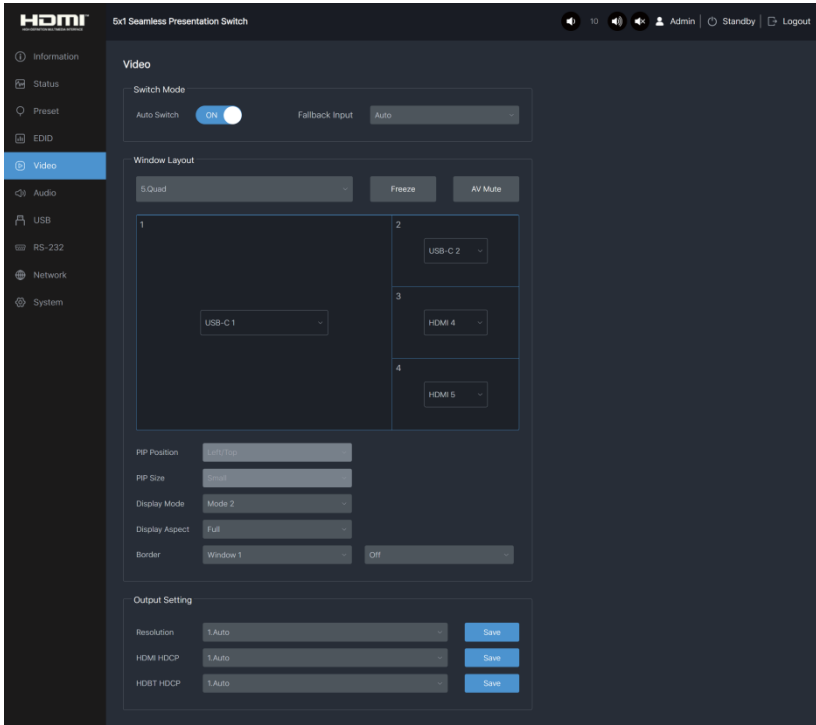

Switch Mode

① **Auto Switch:** You can turn on/off the auto switching function.

② **Fallback Input:** Click the drop-down list to select Auto\USB-C 1\USB-C 2\HDMI 3\HDMI 4\HDMI 5 as the signal source of Fallback input. When the auto switching function is turned on and the current input source is disconnected, the Fallback input signal source will be selected automatically. When the Fallback input is set to be Auto, the switch will detect and switch to the signal with the auto switching sequence of USB-C 1->USB-C 2->HDMI 3->HDMI 4->HDMI 5.

Note: The auto switching function is available only in single screen display mode.

Window layout

① **Window layout:** Click the drop-down list to select the display mode (1.Single\2.PIP\3.PBP\4.Triple\5.Quad).

② **Freeze:** You can freeze the screen.

③ **AV Mute:** You can mute the audio and video.

④ **PIP Position:** Click the drop-down list to select the display position in PIP display mode.

⑤ **PIP Size:** Click the drop-down list to select the display size in PIP display mode.

⑥ **Display Mode:** Click the drop-down list to select the display mode in PBP\Triple\Quad display mode.

⑦ **Display Aspect:** Click the drop-down list to select the display aspect in PBP\Triple\Quad display mode.

⑧ **Border:** Click the drop-down list to select the border and border color in PBP\Triple\Quad display mode.

Output Setting

① **Resolution:** Click the drop-down list to select the output resolution. The output resolution list is as following.

No.	Output Resolution	No.	Output Resolution
1	Auto	9	1920x1080p60
2	3840x2160p60	10	1920x1080p50
3	3840x2160p50	11	1360x768p60
4	4096x2160p60	12	1280x800p60
5	4096x2160p50	13	1280x720p60
6	3840x2160p30	14	1280x720p50
7	3840x2160p25	15	1024x768p60
8	1920x1200p60RB		

Note: When the output resolution is set to Auto, the switch will output the matching resolution based on the EDID of the back-end TV.

② **HDMI HDCP:** Click the drop-down list to select the HDMI HDCP version.

③ **HDBT HDCP:** Click the drop-down list to select the HDBT HDCP version. After setting up, click “Save” to take effect.

■ Audio Page

The screenshot shows the 'Audio' configuration page of the HDMI Seamless Presentation Switch. The interface is dark-themed and includes a sidebar with navigation options: Information, Status, Preset, EDID, Video, Audio (selected), USB, RS-232, Network, and System. The main content area is titled 'Audio' and contains three sections:

- Source Select:** A table of dropdown menus for selecting the source of audio for different outputs. Each dropdown is currently set to 'Main In (HDMI/USB-C In)'. There are 'Save' buttons next to each dropdown.

Output	Source	Action
Main In (HDMI/USB-C In)	HDMI 5	Save
HDMI/HDBT Out	Main In (HDMI/USB-C In)	Save
Line Out	Main In (HDMI/USB-C In)	Save
Dante Out	Main In (HDMI/USB-C In)	Save
- Input Setting:** Three sliders for adjusting the volume of the input sources: Main In (HDMI/USB-C In), Line In, and Dante In. Each slider has a volume icon and a numerical value (100, 100, and 50 respectively).
- Output Setting:** A section for configuring the audio outputs. It includes:
 - Master Out:** A volume slider (0-100) and a 'Mute' icon. The 'HDMI/HDBT Out', 'Line Out', and 'Dante Out' checkboxes are all checked.
 - HDMI/HDBT Out:** A 'Mix Stereo' dropdown menu, a 'Delay' slider (0-60ms), and a volume icon (10).
 - Line Out:** A 'Mix Stereo' dropdown menu, a 'Delay' slider (0-60ms), and a volume icon (10).
 - Dante Out:** A 'Mix Stereo' dropdown menu, a 'Delay' slider (0-60ms), and a volume icon (10).

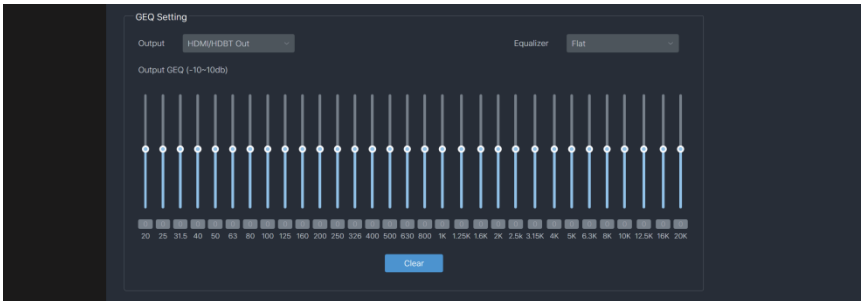

Source Select

- ① **Main In:** Click the drop-down list to select the signal source for Main In.
 - ② **HDMI/HDBT Out:** Click the drop-down list to select the signal source for HDMI/HDBT Out.
 - ③ **Line Out:** Click the drop-down list to select the signal source for Line Out.
 - ④ **Dante Out:** Click the drop-down list to select the signal source for Dante Out.
- After setting up, click “Save” to take effect.

Input Setting: You can respectively set the output volume or mute/unmute the audio for Main In (HDMI/USB-C In)\Line In\Dante In.

Output Setting

- ① **Master Out:** You can respectively set the output volume or mute/unmute the audio for HDMI/HDBT Out\Line Out\Dante Out, or set together when turning on three options synchronously.
- ② **HDMI/HDBT Out\Line Out\Dante Out:** Click the drop-down list of Mix to select the audio output channel for HDMI/HDBT Out\Line Out\Dante Out. You can set the delay, increase/decrease the audio or mute/unmute the audio.

GEQ Setting

- ① **Output:** Click the drop-down list to select the output channel.
- ② **Equalizer:** Click the drop-down list to set the equalizer.
 - Flat: Set all EG to 0db.
 - Custom1: Set EQ for custom 1.
 - Custom2: Set EQ for custom 2.
 - Custom3: Set EQ for custom 3.
 - Custom4: Set EQ for custom 4.
 - Custom5: Set EQ for custom 5.

■ USB Page

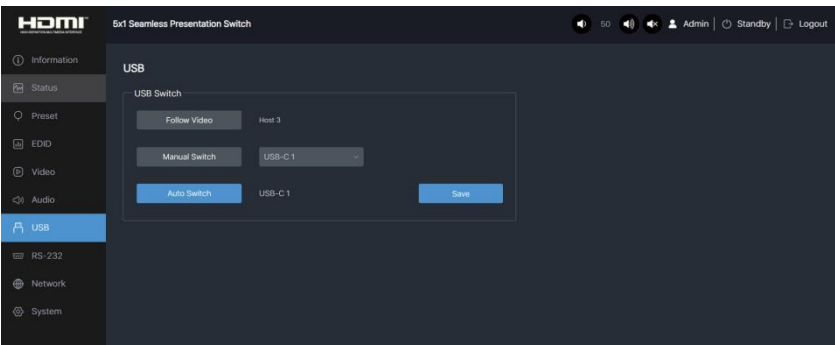

USB Switch

- ① **Follow Video:** Click this button to set the USB transmission follow the video. It will follow the video output of window 1 in multiview mode.
- ② **Manual Switch:** Switch to USB-C 1\USB-C 2\Host 3 manually.
- ③ **Auto Switch:** Detect and switch to USB-C 1\USB-C 2\Host 3 automatically. After setting up, click “Save” to take effect.

■ RS-232 Page

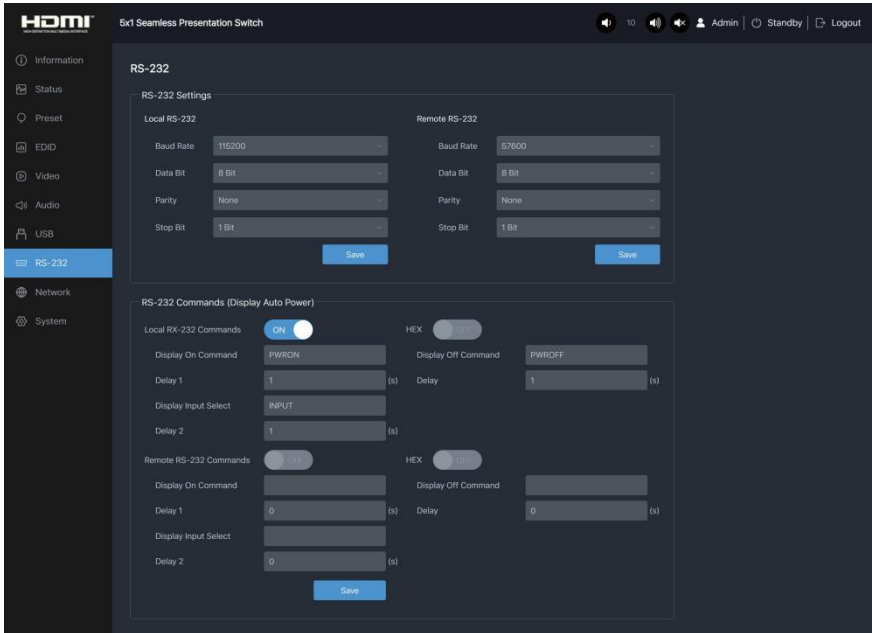

RS-232 Settings

- ① **Local RS-232:** You can set the Baud Rate, Data Bit, Parity and Stop Bit for the RS-232 port of the transmitter.
- ② **Remote RS-232:** You can set the Baud Rate, Data Bit, Parity and Stop Bit for the RS-232 port of the receiver.

RS-232 Commands (Display Auto Power)

- ① **Local/Remote RS-232 Commands:** You can turn on/off the local/remote RS-232 commands and hex.
 - ② **Display On/Off Command:** You can input the display on/off command of the device.
 - ③ **Delay 1:** You can set the delay time for the next action (such as send the Display Input Select command).
 - ④ **Display Input Select:** You can input the command of switching the input channel for the display device.
 - ⑤ **Delay 2:** You can set the delay time for the next action after sending the Display Input Select command.
- After setting up, click “Save” to take effect.

■ Network Page

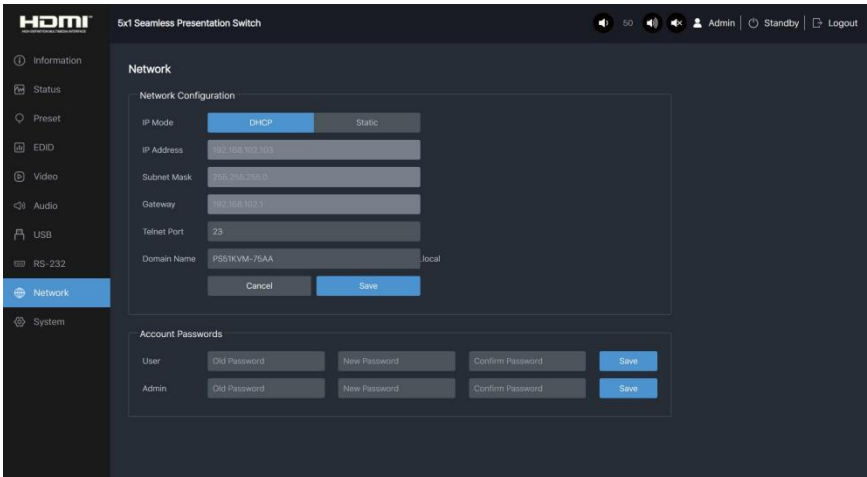

① **Network Configuration:** You can set the IP Mode (DHCP/Static), IP Address, Subnet Mask, Gateway, Telnet Port and Domain Name.

Note: The Domain Name “PS51KVM-75AA.local” can be used to login the Web GUI.

② **Account Passwords:** You can modify the login password for User and Admin. After setting up, click “Save” to take effect.

■ System Page

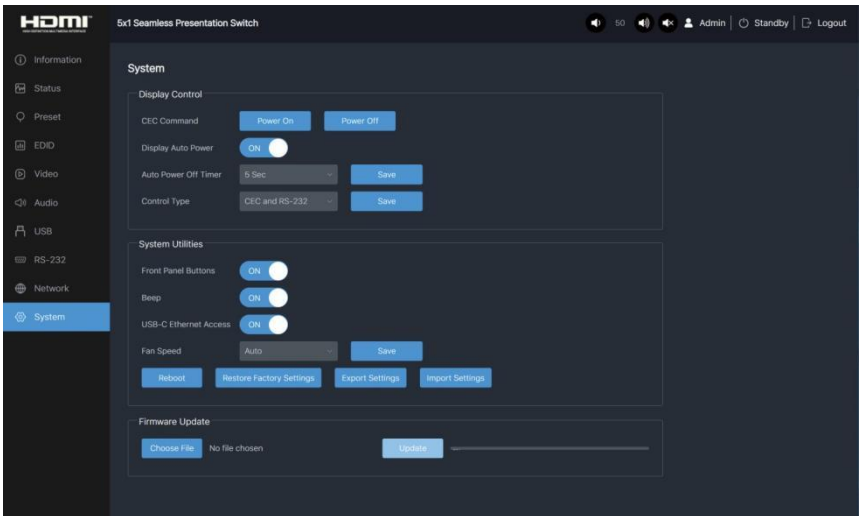

Display Control

① **CEC Command:** You can power on/off the CEC command.

② **Display Auto Power:** You can turn on/off the Display Auto Power. When it is set to ON, you can control the display device power on/off or switch the port based on the power status (power on/standby) or the signal input status of the transmitter by sending serial port or CEC Power On/Off command.

- ③ **Auto Power off Timer:** Click the drop-down list to select the delay time for sending the command to turn off the display device when the transmitter is in standby mode or there is no signal input.
- ④ **Control Type:** Click the drop-down list to select the control type.

System Utilities

- ① **Front Panel Buttons:** Click “ON/OFF” to lock/unlock panel buttons. “On” indicates that panel buttons are available; “OFF” indicates panel buttons are unavailable.
- ② **Beep:** Click “ON/OFF” to turn on/off the beep.
- ③ **USB-C Ethernet Access:** Click “ON/OFF” to turn on/off the Ethernet access function of USB-C.
- ④ **Fan Speed:** Click the drop-down list to set the fan speed.
- ⑤ **Reboot:** Click “Reboot” to reboot the switch.
- ⑥ **Restore Factory Settings:** Click this button to restore the switch to factory settings.
- ⑦ **Export Settings:** Click this button to export configuration files.
- ⑧ **Import Settings:** Click this button to import configuration files.

Firmware Update: You can update the software of MCU, Web, Scaler or receiver. Click “Choose File” to select the update file, then click “Update” to start update. When the progress bar reaches 100%, the update is complete.

8. Dante Web GUI User Guide

There is a built-in Dante Web GUI for the presentation switch. The operation method is shown as below:

Step 1: Connect the presentation switch and PC to the same Ethernet Switch with two Network cables.

Step 2: Set the Network connection setting of PC to be “Obtain an IP address Automatically”.

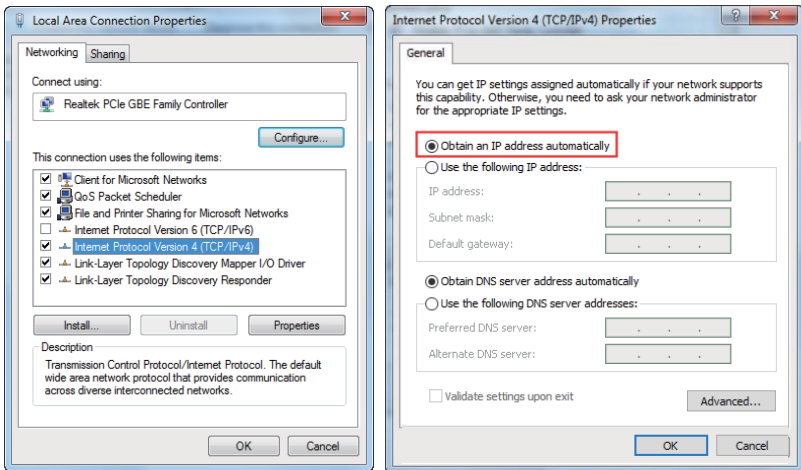

Step 3: Open the Dante Controller software on the PC, and find the Dante device on the Routing page, as shown in the figure below.

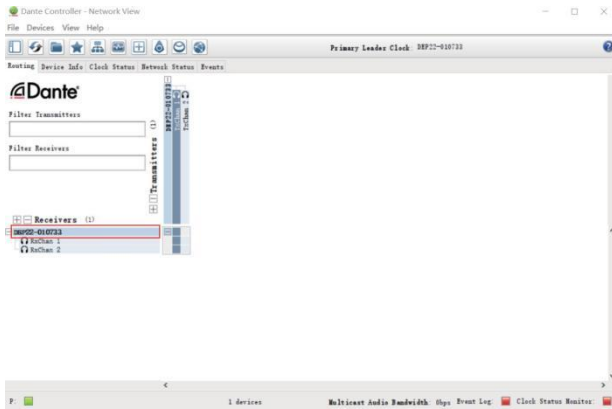

Step 4: Click the Device Info tab to check the IP address of the Dante device.

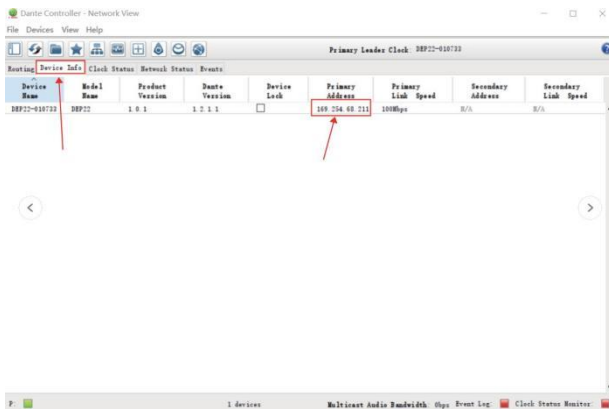

Step 5: Input the IP address of Dante device into your browser on the PC to enter the login interface of the Dante Web GUI.

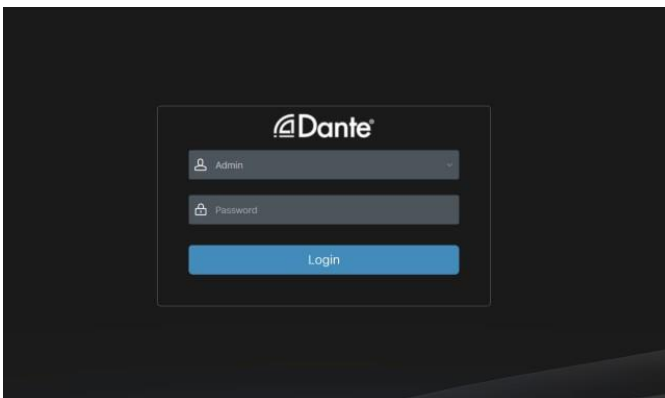

Step 6: Select the default username “Admin” and input the password “admin”, then click the “Login” button to enter the Information page of Dante Web GUI.

■ Information Page

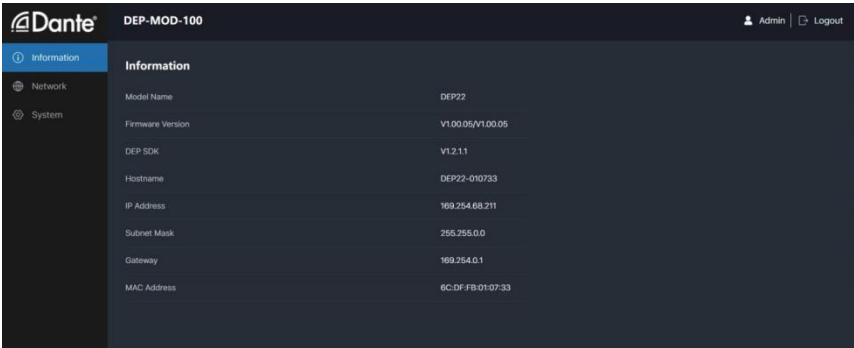

The Information page provides basic information about the model name, software version and IP information.

■ Network Page

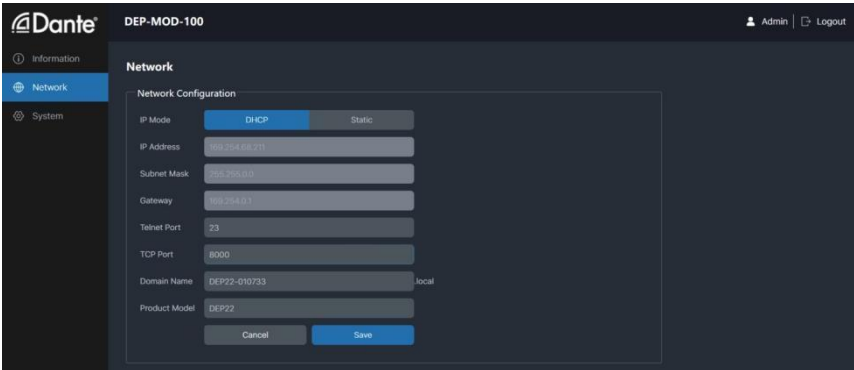

On the Network page, you can set the IP Mode (DHCP/Static), IP Address, Subnet Mask, Gateway, Telnet Port, TCP Port and Domain Name. The model number can also be modified. **Note:** The Domain Name “DEP22-010733.local” can be used to login the Dante Web GUI.

■ System Page

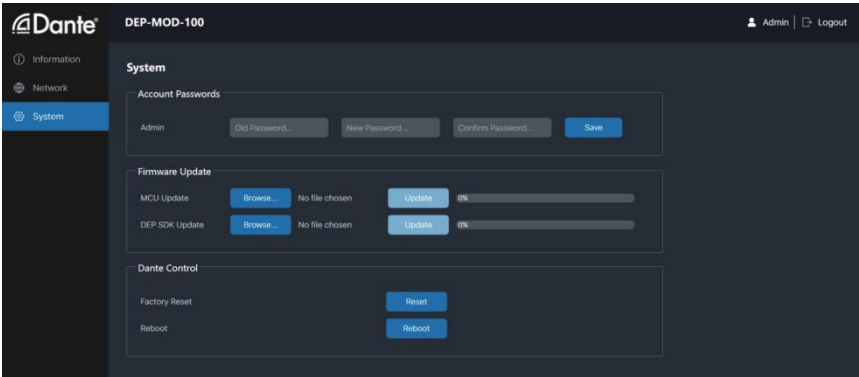

You can do the following operations on the System page:

- ① **Account Passwords:** You can modify the login password for Admin. After inputting the old password, new password and confirm password, click “Save” to take effect.
- ② **Firmware Update:** You can update the firmware and DEP SDK software. Click “Browse” to select the update file, and then click “Update”. When the progress bar reaches 100%, the update is complete.
- ③ **Dante Control:** Click “Reset” to restore to factory settings. Click “Reboot” to reboot the device.

9. RS-232 Control Commands

DVDO-USCB-HDMI-PS-51 also supports RS-232 command control. Connect the RS-232 port of the unit to a PC with a 3-pin phoenix connector cable and an RS-232 to USB cable. The connection method is as follows.

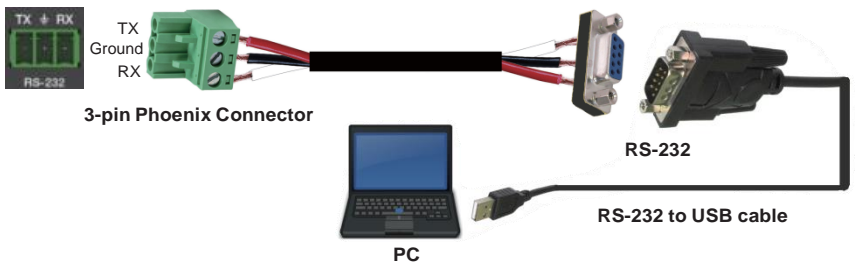

Then open a Serial Command tool on PC to send ASCII commands to control the unit. Below is the list of ASCII commands for DVDO-USCB-HDMI-PS-51:

ASCII Command

Serial port protocol: Baud rate: 115200 (default), Data bits: 8bit, Stop bits:1, Parity bit: none
TCP/IP protocol port: 8000

x - Parameter 1. y - Parameter 2. The end mark of command is "<CR><LF>".

Command Code	Function Description	Example	Feedback	Default Setting
--------------	----------------------	---------	----------	-----------------

System Setting

help	Get the list of all commands	help	<pre> ===== Help Info MCU 1.1.0 Web 1.1.0 Scaler 20230228-10 FPGA 1.1.0 RX 1.18.02 help Get the list of all commands r type Get device model r status Get device current status r fw version Get Firmware version ===== </pre>	List all API commands
r type	Get device model	r type	PS51KVM	
r status	Get device current status	r status	Please refer to the note at the end of the list.	
r fw version	Get Firmware version	r fw version	MCU 1.1.0 Web 1.1.0 Scaler 20230228-10 FPGA 1.1.0 RX 1.18.02	
s power on	Power on the device	s power on	Power on System Initializing... Initialization Finished! MCU 1.1.0 Web 1.1.0 Scaler 20230228-10 FPGA 1.1.0 RX 1.18.02	
s power off	Power off the device	s power off	Power off	
r power	Get current power state	r power	power on /power off	
s reboot	Reboot the device	s reboot	Reboot... System Initializing... Initialization Finished! MCU 1.1.0 Web 1.1.0 Scaler 20230228-10 FPGA 1.1.0 RX 1.18.02	
s reset	Reset to factory defaults	s reset	Reset to factory defaults System Initializing... Initialization Finished! MCU 1.1.0 Web 1.1.0 Scaler 20230228-10 FPGA 1.1.0 RX 1.18.02	
s front button x	Set front button locked on/off (x=0~1) 0. Unlocked 1. Locked	s front button 0	Front button: Unlocked	0
r front button	Get front button locked on/off status	r front button	Front button: Unlocked	
s beep x	Set buzzer on/off (x=0~1) 0. Off 1. On	s beep 1	Beep: On	0
r beep	Get buzzer on/off status	r beep	Beep: Off	
s ir x	Set IR on/off (x=0~1) 0. Off 1. On	s ir 1	IR: On	1
r ir	Get IR on/off status	r ir	IR: Off	

Command Code	Function Description	Example	Feedback	Default Setting
s UsbcAccess Network x	Set USB-C access network feature on/off (x=0~1) 0. Off 1. On	s UsbcAccess Network 1	USB-C Access Network: On	1
r UsbcAccess Network	Get USB-C access network feature on/off	r UsbcAccess Network	USB-C Access Network: On	
s fan speed x	Set fan speed (x=0~4) 0. Auto 1. 25% 2. 50% 3. 75% 4. 100%	s fan speed 0	Fan Speed: Auto	0
r fan speed	Get fan speed	r fan speed	Fan Speed: Auto	
r temp	Get device internal temperature	r temp	Temp: 65C	
Input Setting				
s input x EDID y	Set input EDID (x=0~5) (y=1~16) x=0: all inputs x=1: USB-C 1 x=2: USB-C 2 x=3: HDMI 3 x=4: HDMI 4 x=5: HDMI 5 y=1: Auto (HDBT or HDMI or HDBT+HDMI) y=2: Copy HDMI OUT y=3: Copy HDBT OUT y=4: 4K2K60_444, Stereo Audio 2.0 y=5: 4K2K30_444, Stereo Audio 2.0 y=6: 1080p, Stereo Audio 2.0 y=7: 720p, Stereo Audio 2.0 y=8: 1920x1200, Stereo Audio 2.0 y=9: 1680x1050, Stereo Audio 2.0 y=10: 1600x1200, Stereo Audio 2.0 y=11: 1440x900, Stereo Audio 2.0 y=12: 1360x768, Stereo Audio 2.0 y=13: 1280x1024, Stereo Audio 2.0 y=14: 1024x768, Stereo Audio 2.0 y=15: User Defined 1 y=16: User Defined 2	s input 0 EDID 1	Input USB-C 1 EDID: Auto Input USB-C 2 EDID: Auto Input HDMI 3 EDID: Auto Input HDMI 4 EDID: Auto Input HDMI 5 EDID: Auto	1
r input x EDID	Get input EDID mode (x=0~5) x=0: all inputs x=1: USB-C 1 x=2: USB-C 2 x=3: HDMI 3 x=4: HDMI 4 x=5: HDMI 5	r input 0 EDID	Input USB-C 1 EDID: Auto Input USB-C 2 EDID: Auto Input HDMI 3 EDID: Auto Input HDMI 4 EDID: Auto Input HDMI 5 EDID: Auto	
r input x EdidData	Get input EDID Data (x=0~5) x=0: all inputs x=1: USB-C 1 x=2: USB-C 2 x=3: HDMI 3 x=4: HDMI 4 x=5: HDMI 5	r input 0 EdidData	Input USB-C 1 EDID Data: <00 FF FF FF....> Input USB-C 2 EDID Data: <00 FF FF FF....> Input HDMI 3 EDID Data: <00 FF FF FF....> Input HDMI 4 EDID Data: <00 FF FF FF....> Input HDMI 5 EDID Data: <00 FF FF FF....>	

Command Code	Function Description	Example	Feedback	Default Setting
Output Setting				
s output res x	Set Output Resolution (x=1~15) x=1: Auto x=2: 3840x2160p60 x=3: 3840x2160p50 x=4: 4096x2160p60 x=5: 4096x2160p50 x=6: 3840x2160p30 x=7: 3840x2160p25 x=8: 1920x1200p60RB x=9: 1920x1080p60 x=10: 1920x1080p50 x=11: 1360x768p60 x=12: 1280x800p60 x=13: 1280x720p60 x=14: 1280x720p50 x=15: 1024x768p60	s output res 1	Out Resolution: Auto	1
r output res	Get output resolution	r output res	Out Resolution: Auto	
s output x htcp y	Set output (x=0~2) htcp (y=1~3) x=0: all outputs (HDMI/HDBT) x=1: HDMI output x=2: HDBT output y=1: Auto y=2: HDCP 1.4 y=3: HDCP 2.2	s output 0 htcp 1	Output HDMI HDCP: Auto Output HDBT HDCP: Auto	1
r output x htcp	Get output htcp status (x=0~2) x=0: all outputs (HDMI/HDBT) x=1: HDMI output x=2: HDBT output	r output 0 htcp	Output All HDCP: Auto	
s output avmute x	Set output avmute on/off (x=0~1) x=0: Off x=1: On	s output avmute 1	Output AV Mute: On	0
r output avmute	Get output avmute on/off status	r output avmute	Output AV Mute: On	
s output freeze x	Set output freeze on/off (x=0~1) x=0: Off x=1: On	s output freeze 1	Output Freeze: On	0
r output freeze	Get output freeze on/off status	r output freeze	Output Freeze: On	
s output itc x	Set output video mode (x=1~2) x=1: Video mode x=2: PC mode	s output itc 1	Output ITC: Video Mode	1
r output itc	Get output video mode	r output itc	Output ITC: Video Mode	
Audio Setting				
s main in audio x	Set Main In (HDMI/USB-C In) audio from (x=1~6) x=1: Window 1 x=2: USB-C 1 x=3: USB-C 2 x=4: HDMI 3 x=5: HDMI 4 x=6: HDMI 5	s main in audio 1	Main In Audio: Window 1	1
r main in audio	Get Main In (HDMI/USB-C In) audio source	r main in audio	Main In Audio: Window 1	

Command Code	Function Description	Example	Feedback	Default Setting
s output x audio y	Set output (x=0~3) audio source from (y=1~3) x=0: all outputs (HDMI/HDBT, Line, Dante) x=1: HDMI/HDBT Out x=2: Line Out x=3: Dante Out y=1: Main In (HDMI/USB-C In) y=2: Line In y=3: Dante In	s output 0 audio 1	Output HDMI/HDBT Audio: Main In (HDMI/USB-C In) Output Line Audio: Main In (HDMI/USB-C In) Output Dante Audio: Main In (HDMI/USB-C In)	1
r output x audio	Get output (x=0~3) audio source x=0: all outputs (HDMI/HDBT, Line, Dante) x=1: HDMI/HDBT Out x=2: Line Out x=3: Dante Out	r output 1 audio	Output HDMI/HDBT Audio: Main In (HDMI/USB-C In)	
s input x audio vol+	Increase input (x=0~3) audio volume x=0: all inputs (HDMI/USB-C, Line, Dante) x=1: Main In (HDMI/USB-C In) x=2: Line In x=3: Dante In	s input 1 audio vol+	Input Main In (HDMI/USB-C In) Audio Volume: 50	
s input x audio vol-	Decrease input (x=0~3) audio volume x=0: all inputs (HDMI/USB-C, Line, Dante) x=1: Main In (HDMI/USB-C In) x=2: Line In x=3: Dante In	s input 1 audio vol-	Input Main In (HDMI/USB-C In) Audio Volume: 50	
s input x audio vol y	Set input (x=0~3) audio volume value (y=0~100) x=0: all inputs (HDMI/USB-C, Line, Dante) x=1: Main In (HDMI/USB-C In) x=2: Line In x=3: Dante In	s input 1 audio vol 50	Input Main In (HDMI/USB-C In) Audio Volume: 50	50
r input x audio vol	Get input (x=0~3) audio volume value x=0: all inputs (HDMI/USB-C, Line, Dante) x=1: Main In (HDMI/USB-C In) x=2: Line In x=3: Dante In	r input 1 audio vol	Input Main(HDMI/USB-C In) Audio Volume: 50	
s input x audio mute y	Set input (x=0~3) audio mute on/off (y=0~1) x=0: all inputs (HDMI/USB-C, Line, Dante) x=1: Main In (HDMI/USB-C In) x=2: Line In x=3: Dante In y=0: mute off y=1: mute on	s input 0 audio mute 1	Input Main(HDMI/USB-C In) Audio Mute: On Input Line Audio Mute: On Input Dante Audio Mute: On	0
r input x audio mute	Get input (x=0~3) audio mute on/off x=0: all inputs (HDMI/USB-C, Line, Dante) x=1: Main In (HDMI/USB-C In) x=2: Line In x=3: Dante In	r input 0 audio mute	Input Main (HDMI/USB-C In) Audio Mute: On Input Line Audio Mute: On Input Dante Audio Mute: On	

Command Code	Function Description	Example	Feedback	Default Setting
s master member x y z	Set master output member (x/y/z=0~1) x=0: Exclude HDMI/HDBT Out x=1: Include HDMI/HDBT Out y=0: Exclude Line Out y=1: Include Line Out z=0: Exclude Dante Out z=1: Include Dante Out	s master member 1 1 1	Master Member: 111	111
r master member	Get master output member	r master member	Master Member: 111	
s master audio vol+	Increase master output audio volume	s master audio vol	Master Audio Volume: 50	
s master audio vol-	Decrease master output audio volume	s master audio vol-	Master Audio Volume: 50	
s master audio vol x	Set master output audio volume value (y=0~100)	s master audio vol 50	Master Audio Volume: 50	50
r master audio vol	Get master output audio volume value	r master audio vol	Master Audio Volume: 50	
s master audio mute x	Set master output audio mute on/off (x=0~1) x=0: mute off x=1: mute on	s master audio mute 1	Master Audio Mute: On	0
r master audio mute	Get master output audio mute on/off status	r master audio mute	Master Audio Mute: On	
s output x audio vol+	Increase output (x=0~3) audio volume x=0: all outputs (HDMI/HDBT, Line, Dante) x=1: HDMI/HDBT Out x=2: Line Out x=3: Dante Out	s output 1 audio vol+	Output HDMI/HDBT Audio Volume: 50	
s output x audio vol-	Decrease output (x=0~3) audio volume x=0: all outputs (HDMI/HDBT, Line, Dante) x=1: HDMI/HDBT Out x=2: Line Out x=3: Dante Out	s output 1 audio vol+	Output HDMI/HDBT Audio Volume: 50	
s output x audio vol y	Set output (x=0~3) audio volume value (y=0~100) x=0: all outputs (HDMI/HDBT, Line, Dante) x=1: HDMI/HDBT Out x=2: Line Out x=3: Dante Out	s output 1 audio vol 50	Output HDMI/HDBT Audio Volume: 50	50
r output x audio vol	Get output (x=0~3) audio volume value x=0: all outputs (HDMI/HDBT, Line, Dante) x=1: HDMI/HDBT Out x=2: Line Out x=3: Dante Out	r output 1 audio vol	Output HDMI/HDBT Audio Volume: 50	
s output x audio mute y	Set output (x=0~3) audio mute on/off (y=0~1) x=0: all outputs (HDMI/HDBT, Line, Dante) x=1: HDMI/HDBT Out x=2: Line Out x=3: Dante Out y=0: mute off y=1: mute on	s output 0 audio mute 1	Output HDMI/HDBT Audio Mute: On Output Line Audio Mute: On Output Dante Audio Mute: On	0

Command Code	Function Description	Example	Feedback	Default Setting
r output x audio mute	Get output (x=0~3) audio mute on/off x=0: all outputs (HDMI/HDBT, Line, Dante) x=1: HDMI/HDBT Out x=2: Line Out x=3: Dante Out	r output 0 audio mute	Output HDMI/HDBT Audio Mute: On Output Line Audio Mute: On Output Dante Audio Mute: On	
s output x audio mix y	Set output (x=0~3) audio mix (y=1~4) x=0: all outputs (HDMI/HDBT, Line, Dante) x=1: HDMI/HDBT Out x=2: Line Out x=3: Dante Out y=1: Stereo y=2: Left y=3: Right y=4: Left and Right	s output 0 audio mix 1	Output HDMI/HDBT Audio Mix: Stereo Output Line Audio Mix: Stereo Output Dante Audio Mix: Stereo	Stereo
r output x audio mix	Get output (x=0~3) audio mix mode x=0: all outputs (HDMI/HDBT, Line, Dante) x=1: HDMI/HDBT Out x=2: Line Out x=3: Dante Out	r output 0 audio mix	Output HDMI/HDBT Audio Mix: Stereo Output Line Audio Mix: Stereo Output Dante Audio Mix: Stereo	
s output x audio delay y	Set output (x=0~3) audio delay (y=0~50) x=0: all outputs (HDMI/HDBT, Line, Dante) x=1: HDMI/HDBT Out x=2: Line Out x=3: Dante Out y=[0~50]: Delay Time, Millisecond	s output 0 audio delay 50	Output HDMI/HDBT Audio Delay: 50ms Output Line Audio Delay: 50ms Output Dante Audio Delay: 50ms	0
r output x audio delay	Get output (x=0~3) audio delay value x=0: all outputs (HDMI/HDBT, Line, Dante) x=1: HDMI/HDBT Out x=2: Line Out x=3: Dante Out	r output 0 audio delay	Output HDMI/HDBT Audio Delay: 50ms Output Line Audio Delay: 50ms Output Dante Audio Delay: 50ms	
s output x audio eq y val z	Set output (x=0~3) audio GEQ Index (y=1~31) to value (z=0~20) x=0: all outputs (HDMI/HDBT, Line, Dante) x=1: HDMI/HDBT Out x=2: Line Out x=3: Dante Out y=[1~31]: EQ Index z=[0~20]: EQ Value	s output 0 audio eq 1 val 20	Output HDMI/HDBT Audio EQ Index 1 to Value 20 Output Line Audio EQ Index 1 to Value 20 Output Dante Audio EQ Index 1 to Value 20 Output Dante Audio EQ Preset is Flat Mode	
r output x audio eq y val	Get output (x=0~3) audio GEQ Index (y=1~31) value x=0: all outputs (HDMI/HDBT, Line, Dante) x=1: HDMI/HDBT Out x=2: Line Out x=3: Dante Out y=[1~31]: EQ Index	r output 0 audio eq 1 val	Output HDMI/HDBT Audio EQ Index 1 to Value 20 Output Line Audio EQ Index 1 to Value 20 Output Dante Audio EQ Index 1 to Value 20	

Command Code	Function Description	Example	Feedback	Default Setting
s output x audio eq preset y	Set output (x=0~3) audio GEQ to preset (y=1~6) x=0: all outputs (HDMI/HDBT, Line, Dante) x=1: HDMI/HDBT Out x=2: Line Out x=3: Dante Out y=1: Flat y=2: Custom1 y=3: Custom2 y=4: Custom3 y=5: Custom4 y=6: Custom5	s output 0 audio eq preset 1	Output HDMI/HDBT Audio EQ Preset 1 Output Line Audio EQ Preset 1 Output Dante Audio EQ Preset 1	1
r output x audio eq preset	Get output (x=0~3) audio GEQ preset x=0: all outputs (HDMI/HDBT, Line, Dante) x=1: HDMI/HDBT Out x=2: Line Out x=3: Dante Out	r output 0 audio eq preset	Output HDMI/HDBT Audio EQ Preset 1 Output Line Audio EQ Preset 1 Output Dante Audio EQ Preset 1	
s output x audio eq reset	Set output (x=0~3) audio GEQ reset x=0: all outputs (HDMI/HDBT, Line, Dante) x=1: HDMI/HDBT Out x=2: Line Out x=3: Dante Out	s output 0 audio eq reset	Output HDMI/HDBT Audio EQ Reset Output Line Audio EQ Reset Output Dante Audio EQ Reset	
Single Screen Setting				
s auto switch x	Enable/disable auto switch feature (x=0~1) x=0: Disable auto switch x=1: Enable auto switch	s auto switch 0	Auto Switch: Off	0
r auto switch	Get auto switch feature	r auto switch	Auto Switch: Off	
s input source x	Route input source to output (x=1~5) x=1: USB-C 1 x=2: USB-C 2 x=3: HDMI 3 x=4: HDMI 4 x=5: HDMI 5	s input source 1	Input Source: USB-C 1	1
r input source	Get output selected input source	r input source	Input Source: USB-C 1	
s fallback input x	Set fallback input source (x=0~5) x=0: Next Input x=1: USB-C 1 x=2: USB-C 2 x=3: HDMI 3 x=4: HDMI 4 x=5: HDMI 5	s fallback input 0	Fallback Input: Next Input	0
r fallback input	Get fallback input source	r fallback input	Fallback Input: Next Input	
Multiview Setting				
s multiview x	Set multiview display mode (x=1~5) x=1: Single x=2: PIP x=3: PBP x=4: Triple x=5: Quad	s multiview 1	Multiview: Single	1
r multiview	Get multiview display mode	r multiview	Multiview: Single	

Command Code	Function Description	Example	Feedback	Default Setting
s window x in y	Set window (x=0~4) source from (y=1~5) x=0: All Windows x=1: Window 1 x=2: Window 2 x=3: Window 3 x=4: Window 4 y=1: USB-C 1 y=2: USB-C 2 y=3: HDMI 3 y=4: HDMI 4 y=5: HDMI 5	s window 1 in 1	Window 1 in USB-C 1	
r window x in	Get window (x=0~4) source x=0: All Windows x=1: Window 1 x=2: Window 2 x=3: Window 3 x=4: Window 4	r window 0 in	Window 1 in USB-C 1 Window 2 in USB-C 2 Window 3 in HDMI 3 Window 4 in HDMI 4	
s PIP position x	Set PIP window position (x=1~4) x=1: Left Top x=2: Left Bottom x=3: Right Top x=4: Right Bottom	s PIP position 4	PIP Position: Right Bottom	4
r PIP position	Get PIP window position	r PIP position	PIP Position: Right Bottom	
s PIP size x	Get PIP window size (x=1~3) x=1: Small x=2: Medium x=3: Large	s PIP size 3	PIP Size: Large	3
r PIP size	Get PIP window size	r PIP size	PIP Size: Large	
s PBP mode x	Set PBP windows display mode (x=1~2) x=1: PBP Mode 1 x=2: PBP Mode 2	s PBP mode 1	PBP Mode: Mode 1	1
r PBP mode	Get PBP windows display mode	r PBP mode	PBP Mode: Mode 1	
s PBP aspect x	Set PBP windows display aspect ratio (x=1~2) x=1: Full screen x=2: 16:9	s PBP aspect 1	PBP Aspect: Full Screen	1
r PBP aspect	Get PBP windows display aspect ratio	r PBP aspect	PBP Aspect: Full Screen	
s triple mode x	Set triple windows display mode (x=1~2) x=1: Triple Mode 1 x=2: Triple Mode 2	s triple mode 1	Triple Mode: Mode 1	1
r triple mode	Get triple windows display mode	r triple mode	Triple Mode: Mode 1	
s triple aspect x	Set triple windows display aspect ratio (x=1~2) x=1: Full screen x=2: 16:9	s triple aspect 1	Triple Aspect: Full Screen	1
r triple aspect	Get triple windows display aspect ratio	r triple aspect	Triple Aspect: Full Screen	
s quad mode x	Set quad windows display mode (x=1~2) x=1: Quad Mode 1 x=2: Quad Mode 2	s quad mode 1	Quad Mode: Mode 1	1
r quad mode	Get quad windows display mode	r quad mode	Quad Mode: Mode 1	

Command Code	Function Description	Example	Feedback	Default Setting
s quad aspect x	Set quad windows display aspect ratio (x=1~2) x=1: Full screen x=2: 16:9	s quad aspect 1	Quad Aspect: Full Screen	1
r quad aspect	Get quad windows display aspect ratio	r quad aspect	Quad Aspect: Full Screen	
s window x border y	Set the border(y=0~9) mode of the specified window (x=0~4) x=0: All x=1: Window 1 x=2: Window 2 x=3: Window 3 x=4: Window 4 y=0: Off y=1: Black y=2: Red y=3: Green y=4: Blue y=5: Yellow y=6: Magenta y=7: Cyan y=8: White y=9: Gray	s window 0 border 0	Window 1 Border: Off Window 2 Border: Yellow Window 3 Border: Off Window 4 Border: Cyan	0,0
r window x border	Get the border mode of the specified window (x=0~4) x=0: All x=1: Window 1 x=2: Window 2 x=3: Window 3 x=4: Window 4	r window 0 border	Window 1 Border: Off Window 2 Border: Yellow Window 3 Border: Off Window 4 Border: Cyan	
RX Setting				
s rx input x	Set RX input source (x=1~2) x=1: HDBT IN x=2: HDMI IN	s rx input 1	RX Input: HDBT Error,RX not ready!	1
r rx input	Get RX input source	r rx input	RX Input: HDBT	
r rx hdmi5v	Get RX HDMI input power 5V	r rx hdmi5v	RX HDMI 5V: 1	
r rx host5v	Get RX USB host power 5V	r rx host5v	RX Host 5V: 1	
s rx auto switch mode x	Set RX Auto Switch detection mode (x=1~2) x=1: TMDS x=2: 5V	s rx auto switch mode 1	RX Auto Switch Mode: TMDS	1
r rx auto switch mode	Get RX Auto Switch detection mode	r rx auto switch mode	RX Auto Switch Mode: TMDS	
s rx auto switch x	Set RX Auto Switch on/off (x=0~1) x=0: Off x=1: On	s rx auto switch 1	RX Auto Switch: On	1
r rx auto switch	Get RX Auto Switch on/off	r rx auto switch	RX Auto Switch: On	
CEC Setting				
s cec power on	Set CEC power on command	s cec power on	CEC Power On	
s cec power off	Set CEC power off command	s cec power off	CEC Power Off	
s auto power feature x	Set display auto power feature on/off (x=0~1) x=0: Off x=1: On	s auto power feature 1	Auto Power Feature: On	1
r auto power feature	Get display auto power feature on/off status	r auto power feature	Auto Power Feature: On	

Command Code	Function Description	Example	Feedback	Default Setting
s auto power off timer x	Set auto power off command (CEC/RS-232) will be sent out after x (x=1-6) x=1: 5 sec x=2: 10 sec x=3: 30 sec x=4: 1 min x=5: 5 min x=6: 10 min	s auto power off timer 4	Auto Power Off Timer: 1 min	4
r auto power off timer	Get auto power off timer	r auto power off timer	Auto Power Off Timer: 1 min	
s auto power control x	Set auto power feature control via (x=1-3) x=1: CEC x=2: RS-232 x=3: CEC and RS-232	s auto power control 1	Auto Power Control: CEC	1
r auto power control	Get auto power feature control type	r auto power control	Auto Power Control: CEC	
USB Setting				
s UsbSwitchMode x	Set USB switch mode (x=1-3) x=1: Auto mode (detect USB 5V then switch) x=2: Manual mode x=3: Follow video (HDMI 3 bind with USB Host 3)	s UsbSwitchMode 1	UsbSwitchMode: Auto mode	1
r UsbSwitchMode	Get USB switch mode	r UsbSwitchMode	UsbSwitchMode: Auto mode	
s UsbManual x	Set USB manual switch (x=1-3) x=1: USB-C 1 x=2: USB-C 2 x=3: USB Host 3	s UsbManual 3	UsbManual: USB Host 3	1
r UsbSwitchStatus	Get USB switch status	r UsbSwitchStatus	UsbSwitchStatus: USB-C 1	
RS-232 Setting				
s serial x setting y	Set serial port (x=0-2) setting to y x=0: All RS-232 (Local and HDBT) x=1: Local RS-232 x=2: HDBT RS-232 y= 115200-8n1 Baud rate: 115200/57600/56000/38400/19200/9600/4800/2400 Data bits: 7/8 Parity: n(None)/o(Odd) /e(Even) Stop bits: 1/2	s serial 0 setting 115200-8n1	Local RS-232: 115200-8n1 HDBT RS-232: 115200-8n1	115200-8n1
r serial x setting	Get serial port (x=0-2) setting x=0: All RS-232 (Local and HDBT) x=1: Local RS-232 x=2: HDBT RS-232	r serial 0 setting	Local RS-232: 115200-8n1 HDBT RS-232: 115200-8n1	
Preset Setting				
s preset save x	Save the current unit's settings to the specified preset (x=1-5) All settings except network setting. x=1: Preset 1 x=2: Preset 2 x=3: Preset 3 x=4: Preset 4 x=5: Preset 5	s preset save 1	Preset Save: Preset 1	

Command Code	Function Description	Example	Feedback	Default Setting
s preset recall x	Recall a specified preset into unit (x=1~5) All settings except network setting. x=1: Preset 1 x=2: Preset 2 x=3: Preset 3 x=4: Preset 4 x=5: Preset 5	s preset recall 1	Preset Recall: Preset 1	
s preset clear x	Clear a specified preset into unit (x=1~5) All settings except network setting. x=1: Preset 1 x=2: Preset 2 x=3: Preset 3 x=4: Preset 4 x=5: Preset 5	s preset clear 1	Preset Clear: Preset 1	
s preset x name y	Set preset (x=1~5) name to y (16 characters max) x=1: Preset 1 x=2: Preset 2 x=3: Preset 3 x=4: Preset 4 x=5: Preset 5	s preset 1 name MeetingRoom 1	Preset 1 Name: MeetingRoom 1	
r preset x name	Get preset (x=1~5) name x=1: Preset 1 x=2: Preset 2 x=3: Preset 3 x=4: Preset 4 x=5: Preset 5	r preset x name	Preset 1 Name: MeetingRoom 1	

Network Setting

r ipconfig	Get the Current IP Configuration	r ipconfig	IP Mode: DHCP IP: 192.168.62.106 Subnet Mask: 255.255.255.0 Gateway: 192.168.62.1 TCP/IP port: 8000 Telnet port: 23 MAC: 6C:DF:FB:0C:B3:8E (Static: 169.254.100.200 255.255.0.0 169.254.100.1)	default static IP is 192.168.0.100/ 255.255.0.0/ 192.168.0.1
r mac addr	Get network MAC address	r mac addr	MAC: 6C:DF:FB:0C:B3:8E	
s ip mode x	Set network IP mode to static IP or DHCP (x=0~1) x=0: Static x=1: DHCP	s ip mode 0	IP mode: Static (Please use "s net reboot!" command or repower device to apply new config!)	1
r ip mode	Get network IP mode	r ip mode	IP mode: DHCP	
s ip addr xxx.xxx.xxx.xxx	Set network IP address	s ip addr 192.168.1.100	IP address: 192.168.1.100 (Please use "s net reboot!" command or repower device to apply new config!) DHCP on, Device can't config static address, set DHCP off first.	
r ip addr	Get network IP address	r ip addr	IP: 192.168.62.106	

Command Code	Function Description	Example	Feedback	Default Setting
s subnet xxx.xxx.xxx.xxx	Set network subnet mask	s subnet 255.255.255.0	Subnet Mask: 255.255.255.0 (Please use "s net reboot!" command or repower device to apply new config!) DHCP on, Device can't config subnet mask, set DHCP off first.	
r subnet	Get network subnet mask	r subnet	Subnet Mask: 255.255.255.0	
s gateway xxx.xxx.xxx.xxx	Set network gateway	s gateway 192.168.1.1	Gateway: 192.168.1.1 (Please use "s net reboot!" command or repower device to apply new config!) DHCP on, Device can't config gateway, set DHCP off first.	
r gateway	Get network gateway	r gateway	Gateway: 192.168.1.1	
s tcp/ip port x	Set network TCP/IP port (x=1~65535)	s tcp/ip port 8000	TCP/IP port: 8000	8000
r tcp/ip port	Get network TCP/IP port	r tcp/ip port	TCP/IP port: 8000	
s telnet port x	Set network telnet port (x=1~65535)	s telnet port 23	Telnet port: 23	23
r telnet port	Get network telnet port	r telnet port	Telnet port: 23	
s net reboot	Reboot network modules	s net reboot	Search for IP, Please wait ...! IP Mode: DHCP IP: 192.168.62.106 Subnet Mask: 255.255.255.0 Gateway: 192.168.62.1 TCP/IP port: 8000 Telnet port: 23 MAC: 6C:DF:FB:0C:B3:8E (Static: 169.254.100.200 255.255.0.0 169.254.100.1)	
Password Setting				
s admin password x	Set admin login password (x=[16 characters max])	s admin password admin	admin password: admin	admin
r admin password	Get admin login password	r admin password	admin password: admin	
s user password x	Set user login password (x=[16 characters max])	s user password user	user password: user	user
r user password	Get user login password	r user password	user password: user	

Note: The feedback of the command of "r status" is as following.

=====
Status Info

TX 1.01.04 Web check Scaler 20230626-15 FPGA 2.00.05 RX 1.18.02

Input	Cable	Resolution	ColorSpace	ColorDepth	HDCP	EDID
USB-C 1	Connected	1920x1080p60	RGB	8bit	1.4	AUTO
USB-C 2	Connected	1920x1080p60	RGB	8bit	1.4	4K2K60_444, Stereo Audio 2.0
HDMI 3	Connected	3840x2160p60	RGB	8bit	2.2	AUTO
HDMI 4	Connected	3840x2160p60	YUV 4:4:4	8bit	Off	User Defined 2
HDMI 5	Disconnect	None	None	None	None	AUTO

Output	Cable	Resolution	ColorSpace	ColorDepth	HDCP	AVMute	Source
HDMI OUT	Connected	3840x2160p60Hz	RGB	8bit	2.2	On	1/2/3/4
HDBT OUT	Connected	3840x2160p60Hz	RGB	8bit	2.2	On	1/2/3/4

Power	Key	Beep	IR	UsbcAccessNetwork	FanSpeed	Temp(C)	Baud
On	On	Off	On	On	Auto	65	115200

TCP/IP Telnet MAC

8000 0023 6C:DF:FB:0C:B3:8E

DHCP	IP	Gateway	SubnetMask
On	192.168.062.111	192.168.062.001	255.255.000.000
(Static:	192.168.000.100	192.168.000.001	255.255.000.000)

=====



The terms HDMI and HDMI High-Definition Multimedia interface, and the HDMI Logo are trademarks or registered trademarks of HDMI Licensing LLC in the United States and other countries.

10. Connection Diagram

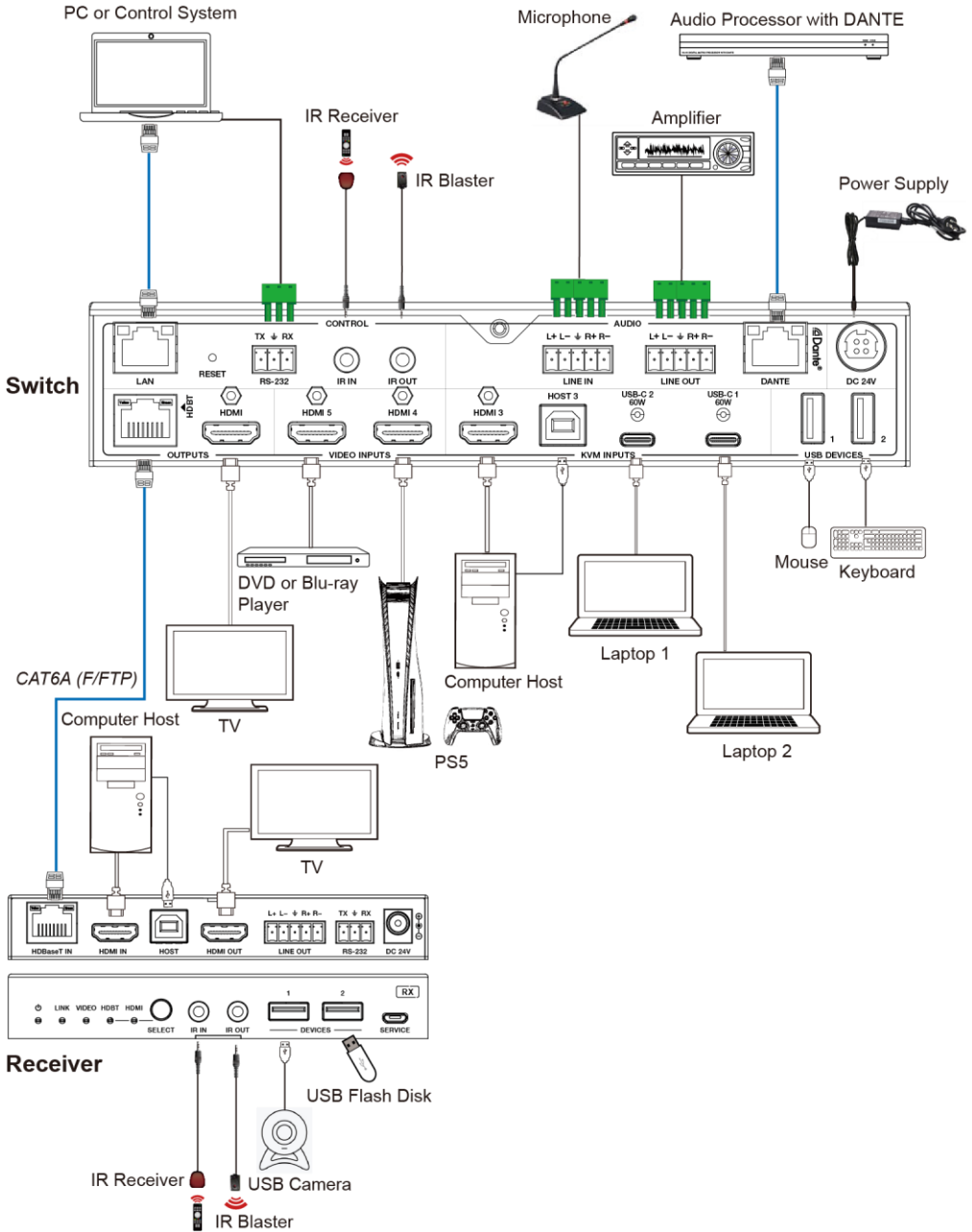

D V D O

Follow us

