

DVDO

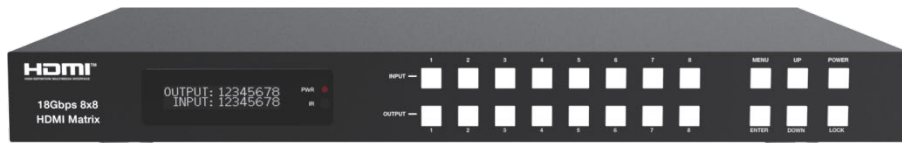











DVDO-Matrix-88

18Gbps 8x8 HDMI Matrix with ARC Function

User Manual

Version: V1.0.0

Important Safety Instructions

- | | | | |
|---|---|---|--|
|  | <p>1. Do not expose this apparatus to rain, moisture, dripping or splashing, and do not place objects filled with liquids, such as vases, on the apparatus.</p> |  | <p>6. Clean this apparatus only with dry cloth.</p> |
|  | <p>2. Do not install or place this unit in a bookcase, built-in cabinet or in any confined space. Ensure the unit is well ventilated.</p> |  | <p>7. Unplug this apparatus during lightning storms or when unused for long periods of time.</p> |
|  | <p>3. To prevent risk of electric shock or fire hazard due to overheating, do not obstruct the unit's ventilation openings with newspapers, tablecloths, curtains, and similar items.</p> |  | <p>8. Protect the power cord from being walked on or pinched, especially at the plug.</p> |
|  | <p>4. Do not install near any heat sources such as radiators, heat registers, stoves, or other apparatus (including amplifiers) that produce heat.</p> |  | <p>9. Only use attachments / accessories specified by the manufacturer.</p> |
|  | <p>5. Do not place sources of naked flames, such as lighted candles, on the unit.</p> |  | <p>10. Refer all servicing to qualified service personnel.</p> |

FCC Warning

This equipment has been tested and found to comply with the limits for a Class B digital device, pursuant to Part 15 of the FCC Rules. These limits are designed to provide reasonable protection against harmful interference in a residential installation. This equipment generates, uses and can radiate radio frequency energy and, if not installed and used in accordance with the instructions, may cause harmful interference to radio communications. However, there is no guarantee that interference will not occur in a particular installation. If this equipment does cause harmful interference to radio or television reception, which can be determined by turning the equipment off and on, the user is encouraged to try to correct the interference by one or more of the following measures:

- Reorient or relocate the receiving antenna.
- Increase the separation between the equipment and receiver.
- Connect the equipment into an outlet on a circuit different from that to which the receiver is connected.
- Consult the dealer or an experienced radio/TV technician for help.

Changes or modifications not expressly approved by the party responsible for compliance could void the user's authority to operate the equipment.

Surge protection device recommended

This product contains sensitive electrical components that may be damaged by electrical spikes, surges, electric shock, lightning strikes, etc. Use of surge protection systems is highly recommended in order to protect and extend the life of your equipment.

Table of Contents

Introduction	5
Features	5
Package Contents	5
Specifications	6
Controls and Functions	7
IR Remote	9
IR Cable Pin Assignment	10
EDID Management	11
Web GUI	13
RS-232 Control	19
Application Example	24

Introduction

This 18Gbps 8x8 HDMI Matrix supports the transmission of video (up to 4K2K@60Hz YUV 4:4:4) and multi-channel high resolution digital audio from 8 HDMI sources to 8 HDMI displays. Audio de-embedded to analog and coaxial audio is supported from 8 HDMI output ports. While HDMI output ARC function is enabled, the ARC audio from HDMI display devices will be extracted to coaxial audio output. Each HDMI output of this 8x8 HDMI Matrix supports 4K2K to 1080P downscaler independently. Control is via front panel buttons, IR remote, RS-232, LAN and Web GUI.

Features

- ☆ HDMI 2.0b, HDCP 2.2 and HDCP 1.4 compliant
- ☆ Video resolution up to 4K2K@60Hz (YUV 4:4:4) on all HDMI ports
- ☆ Support 18Gbps video bandwidth
- ☆ Dolby Vision, HDR10+ and HLG are supported.
- ☆ Support 4K->1080P Down Scaler for each output port
- ☆ HDMI audio pass-through up to 7.1CH HD audio (LPCM, Dolby TrueHD and DTS-HD Master Audio)
- ☆ Audio de-embedded is supported via analog and coax ports
- ☆ ARC, CEC and smart EDID management are supported
- ☆ 1U rack mounted design with front panel OLED display
- ☆ Control via front panel buttons, IR remote, RS-232, LAN and Web GUI

Package Contents

- ① 1 x 18Gbps 8 x 8 HDMI Matrix
- ② 1 x 12V/5A Power Adapter
- ③ 1 x IR Remote
- ④ 1 x IR Receiver cable (1.5 meters)
- ⑤ 1 x RS-232 serial cable (1.5 meters, male to female head)
- ⑥ 2 x Mounting Ear
- ⑦ 1 x User Manual

Specifications

Technical			
HDMI Compliance	HDMI 2.0b		
HDCP Compliance	HDCP 2.2 and HDCP 1.4		
Video Bandwidth	18Gbps		
Video Resolution	Up to 4K2K@50/60Hz (4:4:4)		
Color Space	RGB, YCbCr 4:4:4/4:2:2/4:2:0		
Color Depth	8-bit, 10-bit, 12-bit		
HDMI Audio Formats (Pass-through)	LPCM 2/5.1/7.1, Dolby Digital, DTS 5.1, Dolby Digital+, Dolby TrueHD, DTS-HD Master Audio, Dolby Atmos, DTS:X		
Coax Audio Formats	LPCM 2.0, Dolby Digital / Plus, DTS 5.1		
L/R Audio Formats	PCM2.0		
HDR formats	HDR10,HDR10+,Dolby Vision, HLG		
ESD Protection	Human-body Model: ±8kV (Air-gap discharge) , ±4kV (Contact discharge)		
Connection			
Input Ports	8×HDMI Type A [19-pin female] 1×IR EXT [3.5mm Stereo Mini-jack]		
Output Ports	8×HDMI Type A [19-pin female] 8×Coax Audio (RCA) 8×L/R Audio [3.5mm Stereo Mini-jack]		
Control Ports	1×TCP/IP [RJ45] 1×RS-232 [D-Sub 9]		
Mechanical			
Housing	Metal Enclosure		
Color	Black		
Dimensions	440mm (W)×200mm (D)×44.5mm (H)		
Weight	2.8kg		
Power Supply	Input: AC 100 - 240V 50/60Hz Output: DC 12V/5A (US/EU standard, CE/FCC/UL certified)		
Power Consumption	43W		
Operating Temperature	-10°C ~ 45°C / 14°F ~ 113°F		
Storage Temperature	-20°C ~ 60°C / -4°F ~ 140°F		
Relative Humidity	20~90% RH (non-condensing)		
Resolution / Cable length	4K60 - Feet / Meters	4K30 - Feet / Meters	1080P60 - Feet / Meters
HDMI IN / OUT	16ft / 5M	32ft / 10M	50ft / 15M
The use of "Premium High Speed HDMI" cable is highly recommended.			

Operation Controls and Functions

Front Panel

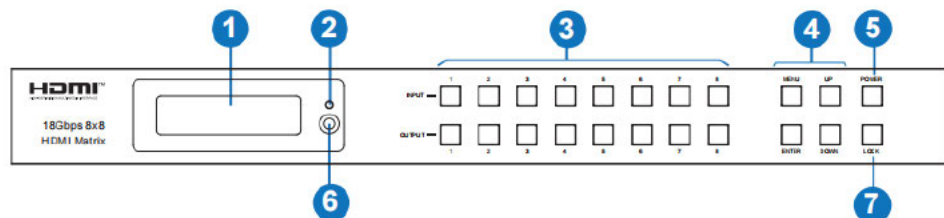

NO.	Name	Function Description
1	OLED screen	Display matrix switching status, input / output port, EDID, Baud rate, IP Address.
2	Power LED	The LED will illuminate in green when the product is connected to power supply, and red when the product is on standby.
3	Input / Output buttons	You need to press an output button (1~8) firstly and then press an input button (1~8) to select the corresponding input source for the output port.
4	MENU / ENTER / UP / DOWN	<p>①EDID Check: On the initial OLED display screen, press "MENU" button to enter the Matrix switching state interface, then press "UP/DOWN" button to check the current EDID information of each HDMI input port.</p> <p>②EDID setting: On the initial OLED display screen, press "MENU" button to enter the EDID setting interface, press "UP/DOWN" button to select the required EDID, and press the "ENTER" button. A prompt "copy to input : " will appear. Then press "UP/DOWN" button to select the input port you need to set, and press "ENTER" button again to confirm.</p> <p>③Baud rate setting: On the initial OLED display screen, press "MENU" button to enter the Baud rate interface, and press "UP/DOWN" button to select the required Baud rate, finally press the "ENTER" button to confirm the setting.</p> <p>④IP Address Check: On the initial OLED display screen, press "MENU" button to enter the IP interface, then press "UP/DOWN" button to check the current IP address. Pressing the "MENU" button again will return to the initial OLED display status.</p>
5	POWER button	Long press the POWER button for 3 seconds to enter the standby mode, then short press it to wake up the device.
6	IR Window	IR receiver window, it only receives the IR remote signal from this product.
7	LOCK button	Short press the LOCK button to lock front panel buttons (Except the power button); Press it again to unlock.

Rear Panel

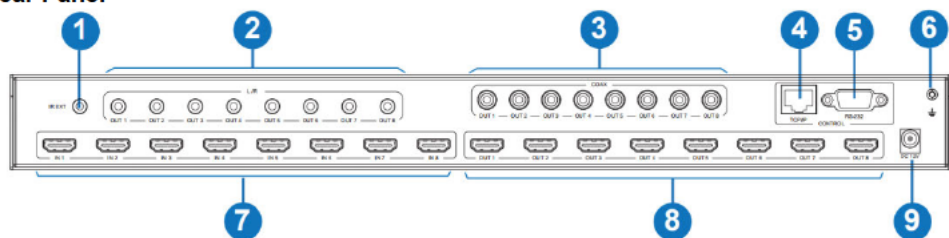

No.	Name	Function Description
1	IR EXT	If the IR receiver window of the unit is blocked or the unit is installed in a closed area out of infrared line of sight, the IR receiver cable can be inserted to the "IR EXT" port to receive the IR remote signal.
2	L/R OUT(1-8)	Analog audio output port, connect to an amplifier or speaker via a 3.5mm audio cable.
3	COAX OUT (1-8)	Coaxial audio output port, connect to audio output device such as audio amplifier via a coaxial cable.
4	TCP/IP port	TCP/IP control port, connect to PC or router with an RJ45 cable.
5	RS-232 port	Connect to a PC or control system by D-Sub 9-pin cable to transmit RS-232 command.
6	GND	Connect the housing to the ground.
7	INPUT ports (1-8)	HDMI input ports , connect to HDMI source device such as DVD or set-top box with an HDMI cable.
8	OUTPUT ports (1-8)	HDMI output ports, connect to HDMI display device such as TV or monitor with an HDMI cable.
9	DC 12V	Connect to 12V/5A power adapter.

IR Remote

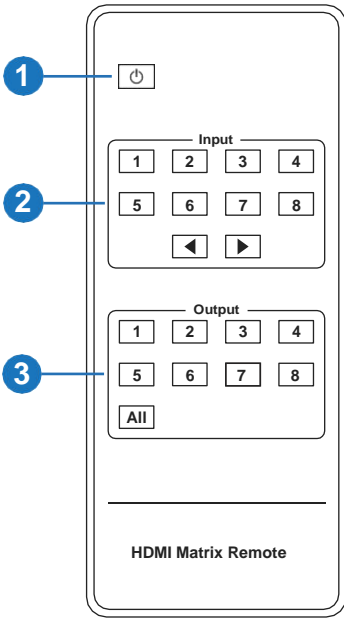

① **Power on or Standby:** Power on the Matrix or set it to standby mode.

② **Input 1/2/3/4/5/6/7/8:** Select input source button.
 ◀ ▶ : Select the last or next input source button.

③ **Output 1/2/3/4/5/6/7/8:** Select output source button.
All: Select all output source simultaneously. For example, when you press the “All” button and then press input “1” button, at this time the input “1” source will output to all display devices.

Operation instruction: You need to press the output button firstly and then press input button to select the corresponding input source. For example, Press Output-X (X means output button from 1 to 8 , including “All” button) Then press Input-Y (Y means input button from 1 to 8)

The Matrix can be selected input and output source by using the IR remote. There are two ways to receive the IR remote signal.

The first way: The IR window accepts the IR remote signal. When using the IR remote, the furthest distance is 7 meters and the angle is $\pm 45^\circ$. The diagram is shown as below:

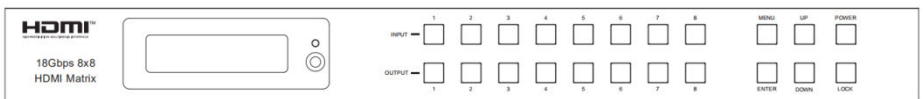

IR remote of the Matrix

The second way: If the IR receiver window of the Matrix is blocked or the Matrix is installed in a closed area out of infrared line of sight, the IR receiver cable can be inserted to the “IR EXT” port to receive the IR remote signal. The furthest distance of using the IR remote is 7 meters and the IR remote is directly faced to the IR receiver head. The diagram is shown as

below.



IR remote of the Matrix



Machine Cabinet

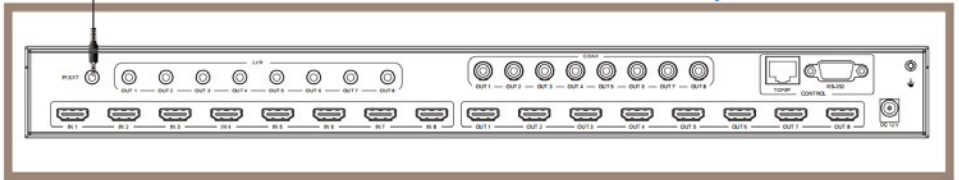

IR Cable Pin Assignment



IR RECEIVER

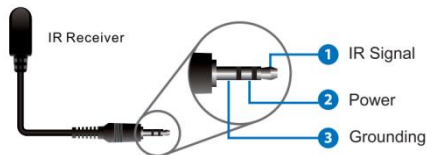

EDID Management

This Matrix has 21 factory defined EDID settings, 2 user-defined EDID modes and 8 copy EDID modes. You can select defined EDID mode or copy EDID mode to input port through front panel buttons, RS-232 control or Web GUI.

On-panel button operation: On the initial OLED display screen, press “MENU” button to enter the EDID setting interface, press “UP/DOWN” button to select the required EDID, and press the “ENTER” button. A prompt “copy to input :” will appear. Then press “UP/DOWN” button to select the input port you need to set, and press “ENTER” button again to confirm this operation.

RS-232 control operation: Connect the Matrix to PC with a serial cable, then open a Serial Command tool on PC to send ASCII command “s edid in x from z!” to set EDID. For details, please refer to “EDID Setting” in the ASCII command list of “10. RS-232 Control Command”.

Web GUI Operation: Please check the EDID management in the “Input page” of “9. Web GUI User Guide”.

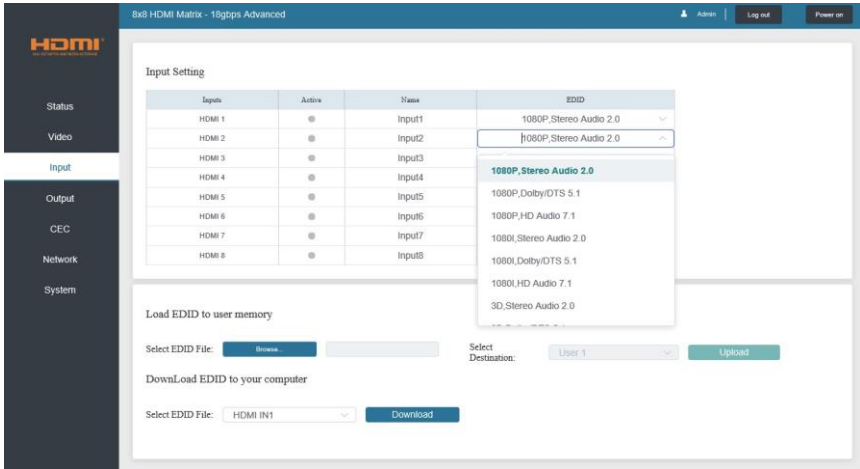

The defined EDID setting list of the product is shown as below:

EDID Mode	EDID Description
1	1080p, Stereo Audio 2.0
2	1080p, Dolby/DTS 5.1
3	1080p, HD Audio 7.1
4	1080i, Stereo Audio 2.0
5	1080i, Dolby/DTS 5.1
6	1080i, HD Audio 7.1
7	3D, Stereo Audio 2.0
8	3D, Dolby/DTS 5.1
9	3D, HD Audio 7.1
10	4K2K30_444, Stereo Audio 2.0
11	4K2K30_444, Dolby/DTS 5.1
12	4K2K30_444, HD Audio 7.1
13	4K2K60_420, Stereo Audio 2.0
14	4K2K60_420, Dolby/DTS 5.1
15	4K2K60_420, HD Audio 7.1
16	4K2K60_444, Stereo Audio 2.0
17	4K2K60_444, Dolby/DTS 5.1
18	4K2K60_444, HD Audio 7.1
19	4K2K60_444, Stereo Audio 2.0 HDR
20	4K2K60_444, Dolby/DTS 5.1 HDR
21	4K2K60_444, HD Audio 7.1HDR
22	USER1
23	USER2
24	Copy from hdmi output 1
25	Copy from hdmi output 2
26	Copy from hdmi output 3
27	Copy from hdmi output 4
28	Copy from hdmi output 5
29	Copy from hdmi output 6
30	Copy from hdmi output 7
31	Copy from hdmi output 8

Web GUI User Guide

The Matrix can be controlled by Web GUI. The operation method is shown as below:

Step 1: Get the current IP Address.

The default IP address is 192.168.1.100. You can get the current Matrix IP address in two ways:

The first way: You can get the IP address via panel buttons. On the initial OLED display, press “MENU” button to enter the IP interface, then press “UP/DOWN” button to check the current IP address.

The second way: You can get the IP address via RS-232 control. Send the command “ r ipconfig!” through an ASCII Command tool, then you’ll get the feedback information as shown below:

```
IP Mode: DHCP
IP:192.168.62.109
Subnet Mask:255.255.255.0
Gateway:192.168.62.1
TCP/IP port:8000
Telnet port:23
Mac address:6c-df-fb-0c-b3-8e
```

IP:192.168.62.109 in the above figure is the IP Address of the Matrix (the IP address is variable, depending on what the specific machine returns).

For the details of ASCII control, please refer to “10. RS-232 Control Command”.

Step 2: Connect the TCP/IP port of the Matrix to a PC with an UTP cable, and set the IP address of the PC to be in the same network segment with the Matrix.

Step 3: Input the IP address of the Matrix into your browser on the PC to enter Web GUI page.



After entering the Web GUI page, there will be a Login page, as shown below:



Select the Username from the list and enter the password. The default passwords are:

Username	User	Admin
Password	user	admin

After entering the password, click the “LOGIN” button and the following Status page will appear.

■ Status Page

The Status page provides basic information about the Model, the installed firmware version and the network settings of the device.

The screenshot shows the 'Status' page of the '8x8 HDMI Matrix - 18Gbps Advanced' device. The page has a dark sidebar with navigation options: Status, Video, Input, Output, CEC, Network, and System. The main content area displays the following information:

Status	
Model	HDP-MX888DA
Firmware Version	V1.00.20/V1.29
Hostname	IP-module-AOC09
IP Address	192.168.1.100
Subnet Mask	255.255.255.0
Gateway	0.0.0.0
MAC Address	6C:DF:FB:0A:0C:09

■ Video Page

The screenshot shows the 'Video' page of the '8x8 HDMI Matrix - 18Gbps Advanced' device. The page has a dark sidebar with navigation options: Status, Video, Input, Output, CEC, Network, and System. The main content area displays the following information:

Switch		Presets			
Output	Input	Presets Name	Presets Set	Presets Save	Presets Clear
Output1	Input1	preset1	Set	Save	Clear
Output2	Input2	preset2	Set	Save	Clear
Output3	Input3	preset3	Set	Save	Clear
Output4	Input4	preset4	Set	Save	Clear
Output5	Input5	preset5	Set	Save	Clear
Output6	Input6	preset6	Set	Save	Clear
Output7	Input7	preset7	Set	Save	Clear
Output8	Input8	preset8	Set	Save	Clear

A dropdown menu is open for 'Input8', showing a list of input options from Input1 to Input8.

You can do the following operations on the Video page:

- ① **Output:** The current device’s OUTPUT port. You can select signal source for it.
- ② **Input:** You can click the drop-down menu to select signal source for the corresponding OUTPUT port .
- ③ **Presets Name:** You can name the current scene with maximum length of 12 characters (Chinese name is unsupported).
- ④ **Presets Set:** You can restore the settings of the last saved audio-video matrix switching relationship.
- ⑤ **Presets Save:** You can save audio-video matrix switching relationship.
- ⑥ **Presets Clear:** You can clear the saved audio-video matrix switching relationship.

■ Input Page

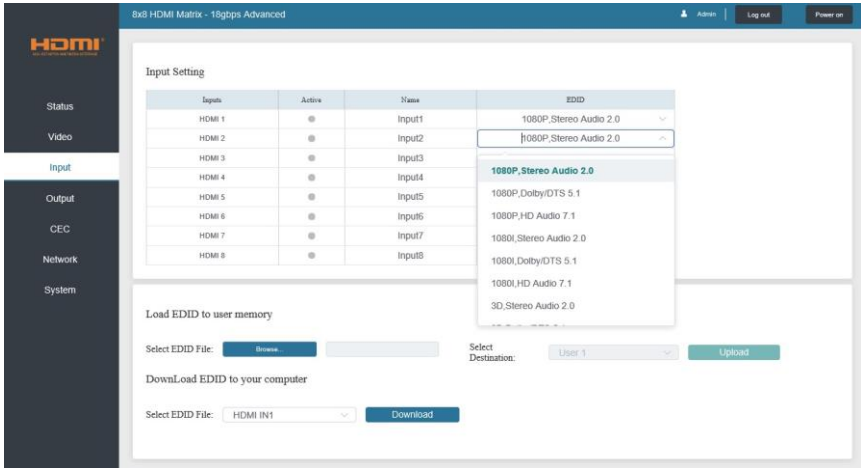

You can do the following operations on the Input page:

- ① **Inputs:** Input channel of the device.
- ② **Active:** It indicates whether the channel is connected to a signal source.
- ③ **Name:** The input channel's name. You can modify it by entering the corresponding name (max length: 12 characters) in the input box (Chinese name is unsupported).
- ④ **EDID:** You can set the current channel's EDID. The specific operation is as follows:

Set EDID for the User

Click the “Browse” button, then select the bin file. If you select the wrong EDID file, there will be a prompt, as shown in the following figure:

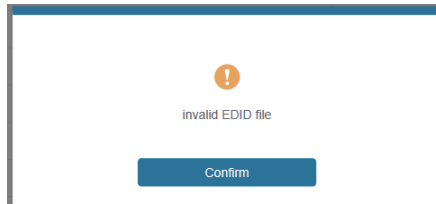

Make sure to select the correct file, then you can check the name of the selected file. Select “User 1” or “User 2”, then click “Upload”. After successful setting, it will prompt as follows:

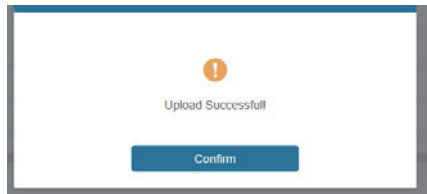

Download the EDID File of the Corresponding Input Channel

Click the drop-down box of “Select EDID File” to select the corresponding input channel. Then click “Download” to download the corresponding EDID file.

■ Output Page

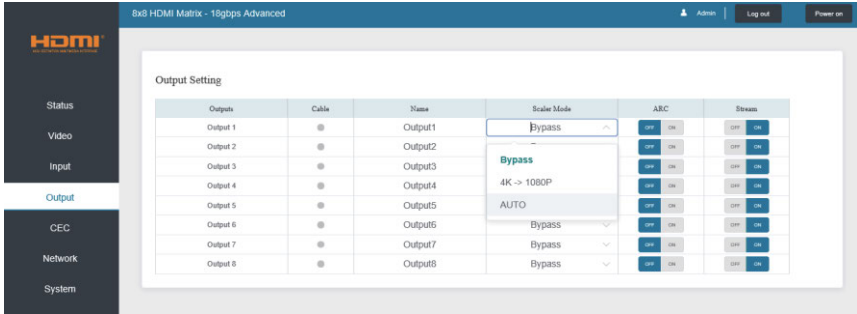

You can do the following operations on the Output page:

- ① **Outputs:** Output channel of the device.
- ② **Name:** The current output channel's name. You can modify it by entering the corresponding name (max length: 12 characters) in the input box (Chinese name is unsupported).
- ③ **Cable:** It indicates the connection status of output ports. When the output port is connected to the display, it shows green, otherwise, it shows gray.
- ④ **Scaler Mode:** Set the current output resolution mode.
- ⑤ **ARC:** Turn on/off the ARC function.
- ⑥ **Stream:** Turn on/off the output stream.

■ CEC Page

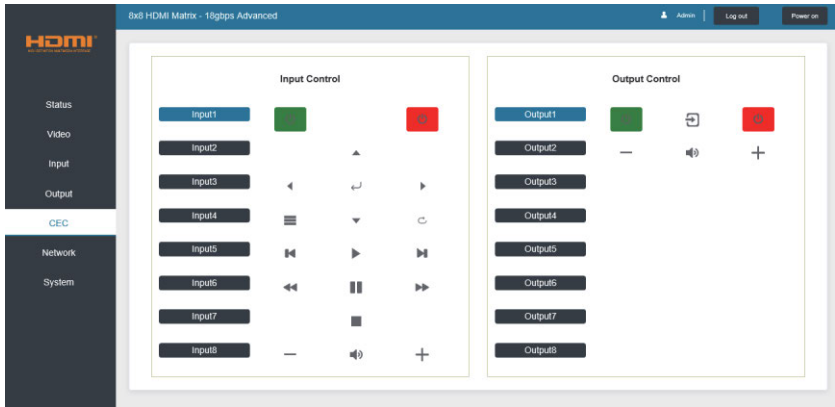

You can perform CEC management on this page:

- ① **Input Control:** You can control the operation of each input source by clicking the icons on the page.
- ② **Output Control:** You can control the operation of each display, such as power on/off, volume +/-, active source switching.

■ Network Page

The screenshot shows the 'bxb HDMI Matrix - 16Gbps Advanced' web interface. On the left is a navigation menu with options: Status, Video, Input, Output, CEC, Network (highlighted), and System. The main content area is titled 'IP Settings' and includes:

- Mode:** Radio buttons for 'Static' and 'DHCP' (selected).
- IP Address:** Text input field containing '192.168.1.100'.
- Gateway:** Text input field containing '0.0.0.0'.
- Subnet Mask:** Text input field containing '255.255.255.0'.
- Trunk Port:** Text input field containing '23'.

Below the IP settings is the 'Web Login Settings' section:

- Username:** Radio buttons for 'User' and 'Admin' (selected).
- Old Password:** Text input field.
- New Password:** Text input field.
- Confirm Password:** Text input field.
- Product Model:** Text input field containing 'HDP-MXB88DA'.

At the bottom of the settings area are two buttons: 'Set Network Defaults' and 'Save'.

Set the Default Network

Click "Set Network Defaults", there will be a prompt, as shown in the following figure:

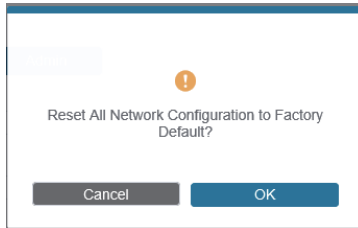

Click "OK" to search the IP Address again, as shown in the following figure:

This screenshot shows the same web interface as above, but with a semi-transparent overlay. In the center of the overlay, there is a green circular icon with a refresh symbol and the text 'Searching IP'. The background settings are dimmed, but the 'Set Network Defaults' and 'Save' buttons are still visible at the bottom.

After searching is completed, it will switch to the login page, the default network setting is completed.

Modify Username

Click the “User” button, enter the correct Old Password, New Password, and Confirm Password, then click “Save”. After successful modification, there will be a prompt, as shown in the following figure:

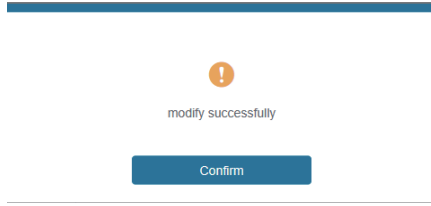

Note: Input rules for changing passwords:

- (1) The password can't be empty.
- (2) New Password can't be the same as Old Password.
- (3) New Password and Confirm Password must be the same.

Modify Network Setting

Modify the Mode/IP Address/Gateway/Subnet Mask/Telnet Port as required, click “Save” to save the settings, then it will come into effect.

After modification, if the Mode is “Static”, it will switch to the corresponding IP Address; if the Mode is “DHCP”, it will automatically search and switch to the IP Address assigned by the router.

IP Settings

Mode	<input type="radio"/> Static	<input checked="" type="radio"/> DHCP		
IP Address	<input type="text" value="192.168.1.100"/>	Gateway	<input type="text" value="0.0.0.0"/>	
Subnet Mask	<input type="text" value="255.255.255.0"/>	Telnet Port	<input type="text" value="23"/>	

■ System Page

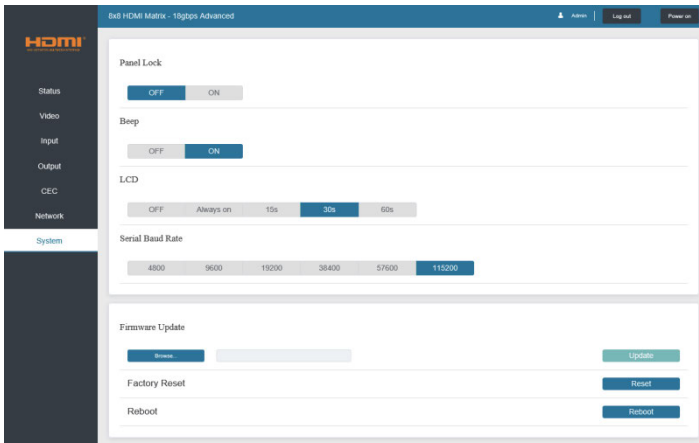

- ① **Panel Lock:** Click "Panel Lock" to lock/unlock panel buttons. "On" indicates that panel buttons are unavailable; "Off" indicates panel buttons are available.
 - ② **Beep:** Click "Beep" to turn on/off the beep.
 - ③ **LCD:** You can turn on/off the LCD, and set the turn-on time (15s/30s/60s).
 - ④ **Serial Baud Rate:** Click the value to set the Serial Baud Rate.
 - ⑤ **Firmware Update:** Click "Browse" to select the update file, then click "Update" to complete firmware update.
 - ⑥ **Factory Reset:** You can reset the unit to factory defaults by clicking "Reset".
 - ⑦ **Reboot:** You can reboot the unit by clicking "Reboot".
- Note:** After reset/reboot, it will switch to the login page.

RS-232 Control Command

The product also supports RS-232 control. You need a serial cable with RS-232 male head and DB9 transfer USB male head. The RS-232 head of the serial cable is connected to the RS-232 control port with DB 9 at the rear of the Matrix, and the USB head of the serial cable is connected to a PC. The connection method is as follows:

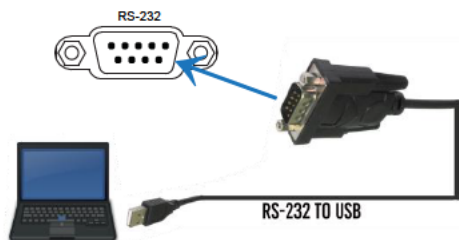

Then, open a Serial Command tool on PC to send ASCII command to control the Matrix. The ASCII command list about the product is shown as below.

ASCII Command				
Serial port protocol. Baud rate: 115200, Data bits: 8bit, Stop bits:1, Check bit: 0				
x - Parameter 1 y - Parameter 2 ! - Delimiter				
Command Code	Function Description	Example	Feedback	Default Setting
Power				
s power z!	Power on/off the device,z=0~1 (z=0 power off, z=1 power on)	s power 1!	Power on System Initializing... Initialization Finished! power off	power on
r power!	Get current power state	r power!	power on/power off	
s reboot!	Reboot the device	s reboot!	Reboot... System Initializing... Initialization Finished! FW version x.xx.xx	
System Setup				
help!	List all commands	help!		
r type!	Get device model	r type!	HDP-MXB88DA	

Command Code	Function Description	Example	Feedback	Default Setting
r status!	Get device current status	r status!	Get the unit all status: power, beep, lock, in/ out connection, video/ audio crosspoint, edid, scaler, network status	
r fw version!	Get Firmware version	r fw version!	MCU BOOT: Vx.xx.xx MCU APP: Vx.xx.xx WEB GUI: Vx.xx	
r link in x!	Get the connection status of the x input port, x=0~8(0=all)	r link in 1!	hdmi input 1: connect	
r link out y!	Get the connection status of the y output port, y=0~8(0=all)	r link out 1!	hdmi output 1: connect	
s reset!	Reset to factory defaults	s reset!	Reset to factory defaults System Initializing... Initialization Finished! FW version x.xx.xx	
s beep z!	Enable/Disable buzzer function, z=0~1(z=0 beep off, z=1 beep on)	s beep 1!	beep on beep off	beep on
r beep!	Get buzzer state	r beep!	beep on / beep off	
s lock z!	Lock/Unlock front panel button, z=0~1 (z=0 lock off,z=1 lock on)	s lock 1!	panel button lock on panel button lock off	panel button lock off
r lock!	Get panel button lock state	r lock!	panel button lock on/off	
s lcd on time z!	Set LCD screen remain on time, z=0~4 (0:off, 1:always on, 2:15s, 3:30s, 4:60s)	s lcd on time 1!	lcd on 15 seconds	lcd on 30 seconds
r lcd mode!	Get the backlight status of lcd screen	r lcd mode!	lcd always on	
s save preset z!	Save switch state between all output port and the input port to preset z, z=1~8	s save preset 1!	save to preset 1	
s recall preset z!	Call saved preset z scenarios, z=1~8	s recall preset 1!	recall from preset 1	
s clear preset z!	Clear stored preset z scenarios, z=1~8	s clear preset 1!	clear preset 1	
r preset z!	Get preset z information, z=1~8	r preset 1!	video/audio crosspoint	
s logo1 *****!	Set the logo name displayed on the first line of LCD screen,the max character is 16	s logo1 Initializing...!	logo1:Initializing...	
s logo2 *****!	Set the logo name displayed on the second line of LCD screen,the max character is 16	s logo2 HDP-MXB88DA!	logo2 HDP-MXB88DA!	
s baud rate xxx!	Set the serial port baud rate of RS02 module, z=(115200,57600, 38400,19200,9600,4800)	s baud rate 115200!	Baudrate:115200	115200
r baud rate!	Get the serial port baud rate of RS02 module	r baud rate!	Baudrate:115200	
s id z!	Set the control ID of the product, z=000~999	s id 888!	id 888!	0
Output Setting				
s in x av out y!	Set input x to output y, x=1~8, y=0~8(0=all)	s in 1 av out 2!	input 1 -> output 2	PTP
r av out y!	Get output y signal status y=0~8(0=all)	r av out 0!	input 1 -> output 1 input 2 -> output 2 input 8 -> output 8	

Command Code	Function Description	Example	Feedback	Default Setting
s hdmi y stream z!	Set output y stream on/off, y=0~8 (0=all) z=0~1(0:disable,1:enable)	s hdmi 1 stream 1! s hdmi 0 stream 1!	Enable hdmi output 1 stream Disable hdmi output 1 stream Enable hdmi all outputs stream Disable hdmi all outputs stream	enable
r hdmi y stream!	Get output y stream status, y=0~8(0=all)	r hdmi 1 stream!	Enable hdmi output 1 stream	
s hdmi y scaler z!	Set hdmi output y port output scaler mode . y=0~8(0=all), z=1~3(1=bypass,2=4k->1080p, 3=Auto)	s hdmi 1 scaler 1! s hdmi 0 scaler 1!	hdmi output 1 set to bypass mode hdmi all outputs set to bypass mode	hdmi all outputs set to bypass mode
r hdmi y scaler!	Get hdmi output y port output mode y=0~8(0=all)	r hdmi 1 scaler !	hdmi output 1 set to bypass mode	
EDID Setting				
s edid in x from z!	Set input x EDID from default EDID z, x=0~8(0=all),z=1~31 1, 1080p, Stereo Audio 2.0 2, 1080p, Dolby/DTS 5.1 3, 1080p, HD Audio 7.1 4, 1080i, Stereo Audio 2.0 5, 1080i, Dolby/DTS 5.1 6, 1080i, HD Audio 7.1 7, 3D, Stereo Audio 2.0 8, 3D, Dolby/DTS 5.1 9, 3D, HD Audio 7.1 10, 4K2K30_444, Stereo Audio 2.0 11, 4K2K30_444, Dolby/DTS 5.1 12, 4K2K30_444, HD Audio 7.1 13, 4K2K60_420, Stereo Audio 2.0 14, 4K2K60_420, Dolby/DTS 5.1 15, 4K2K60_420, HD Audio 7.1 16, 4K2K60_444, Stereo Audio 2.0 17, 4K2K60_444, Dolby/DTS 5.1 18, 4K2K60_444, HD Audio 7.1 19, 4K2K60_444, Stereo Audio 2.0 HDR 20, 4K2K60_444, Dolby/DTS 5.1 HDR 21, 4K2K60_444, HD Audio 7.1 HDR 22, User1 23, User2 24~31, copy from hdmi output 1~8	s edid in 1 from 1! s edid in 0 from 1!	input 1 EDID:1080p, Stereo Audio 2.0 all inputs EDID:1080p, Stereo Audio 2.0	1080p, Stereo Audio 2.0
r edid in x!	Get EDID status of the input x . x=0~8(0=all input)	r edid in 0!	input 1 EDID: 4K2K60_444, Stereo Audio 2.0 input 8 EDID: 4K2K60_444, Stereo Audio 2.0	
r edid data hdmi y!	Get the EDID data of the hdmi output y port . y=1~8	r edid data hdmi 1!	EDID: 00 FF FF FF FF FF FF FF 00	
Audio Setting				
s hdmi y arc z!	Turn on/off ARC of HDMI output y, y=0~8(0=all) z=0~1(z=0,off,z=1 on)	s hdmi 1 arc 1! s hdmi 0 arc 1!	hdmi output 1 arc on hdmi output 1 arc off hdmi all outputs arc on hdmi all outputs arc off	off
r hdmi y arc!	Get the ARC state of HDMI output y . y=0~8(0=all)	r hdmi 1 arc!	hdmi output 1 arc on	

Command Code	Function Description	Example	Feedback	Default Setting
CEC Setting				
s cec in x on!	set input x power on by CEC, x=0~8(0=all input)	s cec in 1 on!	input 1 power on	
s cec in x off!	set input x power off by CEC, x=0~8(0=all input)	s cec in 1 off!	input 1 power off	
s cec in x menu!	set input x open menu by CEC, x=0~8(0=all input)	s cec in 1 menu!	input 1 open menu	
s cec in x back!	set input x back operation by CEC, x=0~8(0=all input)	s cec in 1 back!	input 1 back operation	
s cec in x up!	set input x menu up operation by CEC, x=0~8(0=all input)	s cec in 1 up!	input 1 menu up operation	
s cec in x down!	set input x menu down operation by CEC, x=0~8(0=all input)	s cec in 1 down!	input 1 menu down operation	
s cec in x left!	set input x menu left operation by CEC, x=0~8(0=all input)	s cec in 1 left!	input 1 menu left operation	
s cec in x right!	set input x menu right operation by CEC, x=0~8(0=all input)	s cec in 1 right!	input 1 menu right operation	
s cec in x enter!	set input x menu enter by CEC, x=0~8(0=all input)	s cec in 1 enter!	input 1 menu enter operation	
s cec in x play!	set input x play by CEC, x=0~8(0=all input)	s cec in 1 play!	input 1 play operation	
s cec in x pause!	set input x pause by CEC, x=0~8(0=all input)	s cec in 1 pause!	input 1 pause operation	
s cec in x stop!	set input x stop by CEC, x=0~8(0=all input)	s cec in 1 stop!	input 1 stop operation	
s cec in x rew!	set input x rewind by CEC, x=0~8(0=all input)	s cec in 1 rew!	input 1 rewind operation	
s cec in x mute!	set input x volume mute by CEC, x=0~8(0=all input)	s cec in 1 mute!	input 1 volume mute	
s cec in x vol-!	set input x volume down by CEC, x=0~8(0=all input)	s cec in 1 vol-!	input 1 volume down	
s cec in x vol+!	set input x volume up by CEC, x=0~8(0=all input)	s cec in 1 vol+!	input 1 volume up	
s cec in x ffl!	set input x fast forward by CEC, x=0~8(0=all input)	s cec in 1 ffl!	input 1 fast forward operation	
s cec in x previous!	set input x previous by CEC, x=0~8(0=all input)	s cec in 1 previous!	input 1 previous operation	
s cec in x next!	set input x next by CEC, x=0~8(0=all input)	s cec in 1 next!	input 1 next operation	
s cec hdmi out y on!	set output y power on by CEC, y=0~8(0=all output)	s cec hdmi out 1 on!	hdmi output 1 power on	
s cec hdmi out y off!	set output y power off by CEC, y=0~8(0=all output)	s cec hdmi out 1 off!	hdmi output 1 power off	
s cec hdmi out y mute!	set output y volume mute by CEC, y=0~8(0=all output)	s cec hdmi out 1 mute!	hdmi output 1 volume mute	
s cec hdmi out y vol-!	set output y volume down by CEC, y=0~8(0=all output)	s cec hdmi out 1 vol-!	hdmi output 1 volume down	
s cec hdmi out y vol+!	set output y volume up by CEC, y=0~8(0=all output)	s cec hdmi out 1 vol+!	hdmi output 1 volume up	
s cec hdmi out y active!	set output y active source by CEC, y=0~8(0=all output)	s cec hdmi out 1 active!	hdmi output 1 active source	

Command Code	Function Description	Example	Feedback	Default Setting
Network Setting				
r ipconfig!	Get the Current IP Configuration	r ipconfig!	IP Mode: Static IP: 192.168.1.72 Subnet Mask: 255.255.255.0 Gateway: 192.168.1.1 TCP/IP port=8000 Telnet port=10 Mac address: 00:1C:91:03:80:01	
r mac addr!	Get network MAC address	r mac addr!	Mac address: 00:1C:91:03:80:01	
s ip mode z!	Set network IP mode to static IP or DHCP, z=0~1 (z=0 Static, z=1 DHCP)	s ip mode 0!	Set IP mode:Static (Please use "s net reboot!" command or repower device to apply new config!)	
r ip mode!	Get network IP mode	r ip mode!	IP Mode: Static	
s ip addr xxx.xxx.xxx.xxx!	Set network IP address	s ip addr 192.168.1.100!	Set IP address: 192.168.1.100 (Please use "s net reboot!" command or repower device to apply new config!) DHCP on, Device can't config static address, set DHCP off first.	
r ip addr!	Get network IP address	r ip addr!	IP address: 192.168.1.100	
s subnet xxx.xxx.xxx.xxx!	Set network subnet mask	s subnet 255.255.255.0!	Set subnet Mask: 255.255.255.0 (Please use "s net reboot!" command or repower device to apply new config!) DHCP on, Device can't config subnet mask, set DHCP off first.	
r subnet!	Get network subnet mask	r subnet!	Subnet Mask: 255.255.255.0	
s gateway xxx.xxx.xxx.xxx!	Set network gateway	s gateway 192.168.1.1!	Set gateway: 192.168.1.1 Please use "s net reboot!" command or repower device to apply new config! DHCP on, Device can't config gateway, set DHCP off first.	
r gateway!	Get network gateway	r gateway!	Gateway:192.168.1.1	
s tcp/ip port x!	Set network TCP/IP port (x=1~65535)	s tcp/ip port 8000!	Set TCP/IP port:8000	
r tcp/ip port!	Get network TCP/IP port	r tcp/ip port!	TCP/IP port:8000	
s telnet port x!	Set network telnet port (x=1~65535)	s telnet port 23!	Set Telnet port:23	
r telnet port!	Get network telnet port	r telnet port!	Telnet port:23	

Command Code	Function Description	Example	Feedback	Default Setting
s net reboot!	Reboot network modules	s network reboot!	Network reboot... IP Mode: Static IP: 192.168.1.72 Subnet Mask: 255.255.255.0 Gateway: 192.168.1.1 TCP/IP port=8000 Telnet port=10 Mac address: 00:1C:91:03:80:01	

Application Example

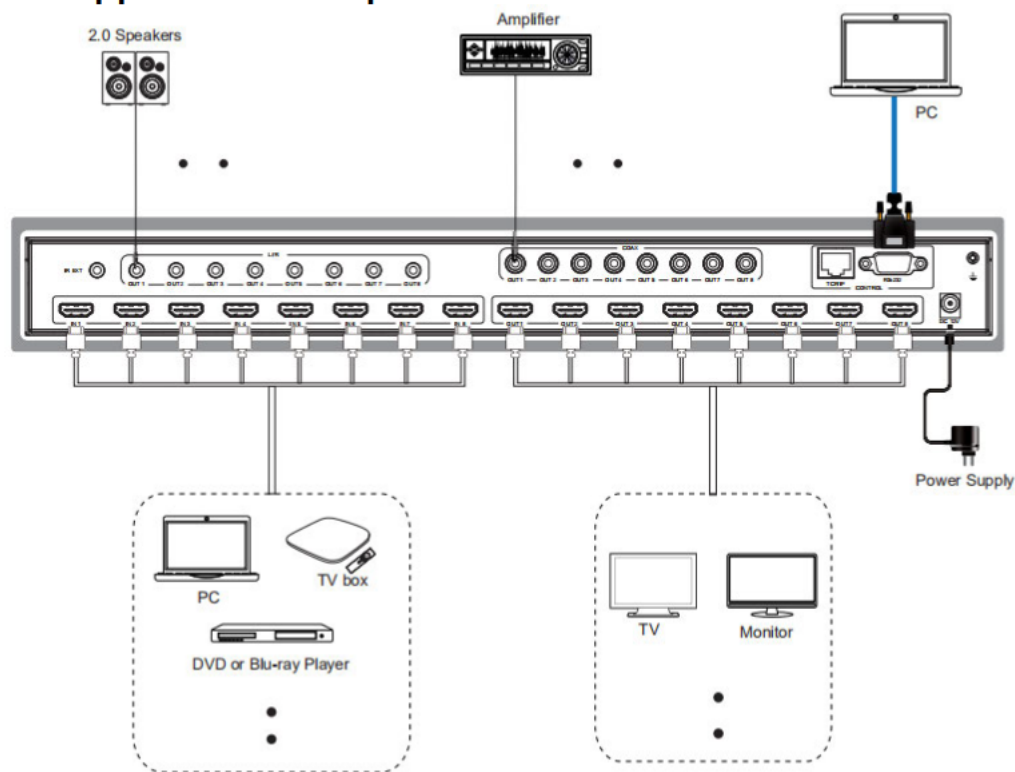

HDMI™
HIGH DEFINITION MULTIMEDIA INTERFACE

The terms HDMI and HDMI High-Definition Multimedia interface, and the HDMI Logo are trademarks or registered trademarks of HDMI Licensing LLC in the United States and other countries.