

RUBICON
LIGHTING

REFORM





Features:

- Efficacy Of Up To 112lm/W*
- New Gen-6 COB
- Passive Cooling
- Tilt & Rotate Action
- Minimum Lumen Maintenance: 50 000h (L80B10)



Power Supply:	220-240V AC 50 - 60Hz				
Operating Temperature Range: (Ta - Ambient)	- 20°C to 35°C				
Colour Rendering Index:	CRI 80+ _ CRI 90+				
Colour Consistency:	2-Step MacAdam				
Colour Temperature: (Kelvin / CCT)	<input type="radio"/> 2700K <input type="radio"/> 3500K <input type="radio"/> 5000K <input type="radio"/> 3000K <input type="radio"/> 4000K				
Beam Angle:	10° _ 24° _ 30° _ 50°				
Installation Type:	3-Phase Track				
Ingress Protection:	IP20				
Luminaire Colour:	<input type="radio"/> White <input type="radio"/> Black <input type="radio"/> Silver				
Material:	Housing - Powder Coated Die-Cast Aluminium Diffuser - Clear Protective Glass				
	Dimensions	Wattage (System)	CRI	Kelvin	Luminous Flux (Effective)
	Ø129mm x 191mm x 228mm	28W	80+	3000K	3675Lm*
	Ø129mm x 191mm x 228mm	31W	80+	4000K	4175Lm*
	Ø129mm x 191mm x 228mm	33W	80+	5000K	4225Lm*
	Ø129mm x 191mm x 228mm	28W	90+	3000K	2975Lm*
	Ø129mm x 191mm x 228mm	31W	90+	3500K	3350Lm*
	Ø129mm x 191mm x 228mm	33W	90+	4000K	3700Lm*

*E & O.E (Errors And Omissions Excepted)

*Due to the rapid development in LED technology the performance values, power consumption and lumen output levels stated above are subject to change without prior notice.

*All lumen outputs stated above are based a nominal output that included a 10% light loss, this can vary depending on the optic used.

Dimensions:

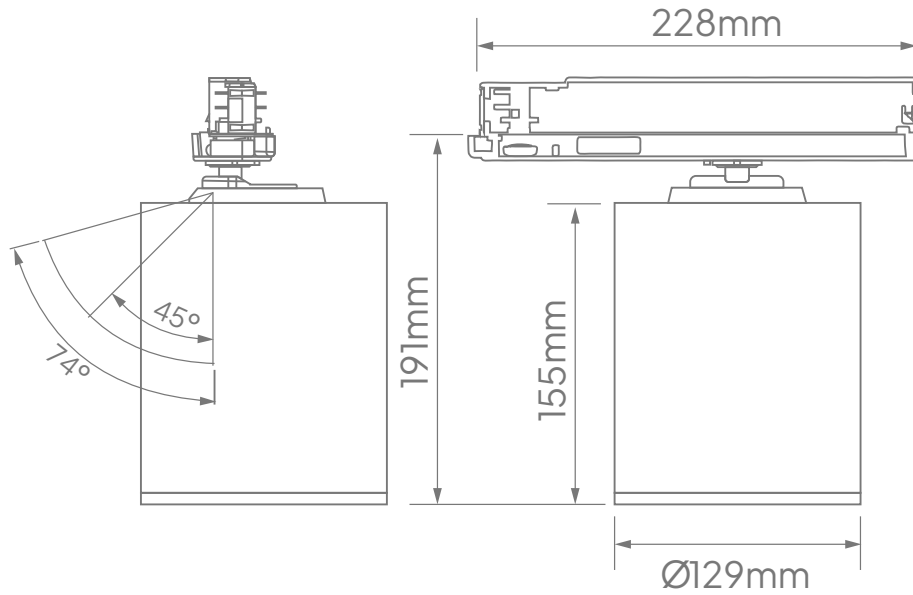

*E & O.E (Errors And Omissions Excepted)

*Due to the rapid development in LED technology the performance values, power consumption and lumen output levels stated above are subject to change without prior notice.

*All lumen outputs stated above are based a nominal output that included a 10% light loss, this can vary depending on the optic used.

Contact

Cape Town

1B Hansen Close,
Richmond Park,
Cape Town
T. +27 21 555 0570

Durban

Unit L, Nandi Park,
34 Brickworks Way
Briardene
T. +27 31 001 2964

Namibia – Windhoek

Unit 2, Tesoro Building,
31 TV More Street
Windhoek
T. +264 61 40 0339

Johannesburg

17 Galaxy Road,
Unit 5A Galaxy Park,
Linbro Park
T. +27 11 262 5179

Port Elizabeth

216 Main Road,
Walmer
Port Elizabeth
T. +27 41 451 4359