

**RUBICON**  
LIGHTING

## PICTOR ROAD





**Features:**

- Efficacy Of Up To 164Lm/ W\*
- 12 Year Battery Lifespan
- 25 Year Photovoltaic Panel Lifespan
- Cellphone Based Monitoring
- Built In Motion Sensor
- Optional Off Site Monitoring & Communication
- Resistant To Extreme Climates
- Plug And Play Installation
- Minimum Lumen Maintenance: 50 000h (L80B10)



<b>Battery:</b>	24V NiMH High Temperature
<b>Photovoltaic Panels:</b>	Mono-Crystalline 80W (2x 40WP)
<b>Operating Temperature Range: (Ta - Ambient)</b>	- 20°C to +70°C
<b>Colour Temperature: (Kelvin / CCT)</b>	<input checked="" type="radio"/> 3000K <input type="radio"/> 5700K <input type="radio"/> 4000K
<b>Luminous Flux:</b>	3200lm - No Motion 5600lm - Motion Detected
<b>Wattage:</b>	20W - No Motion 50W - Motion Detected
<b>Ingress Protection:</b>	IP65
<b>IK Rating:</b>	IK08
<b>Material:</b>	ABS PMMA Casting Aluminium

**Exploded View:**

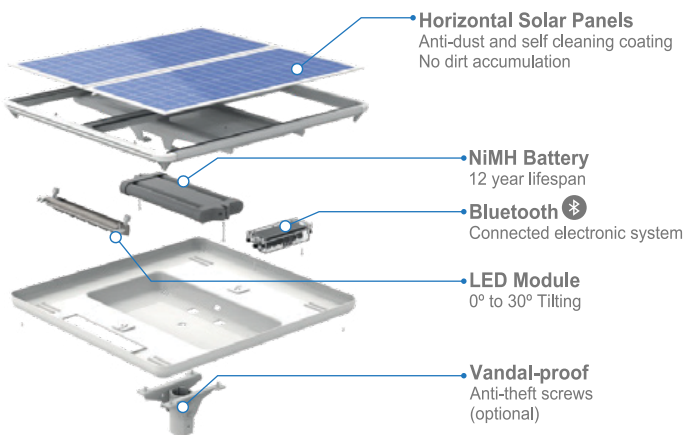

**Lighting Performance:**

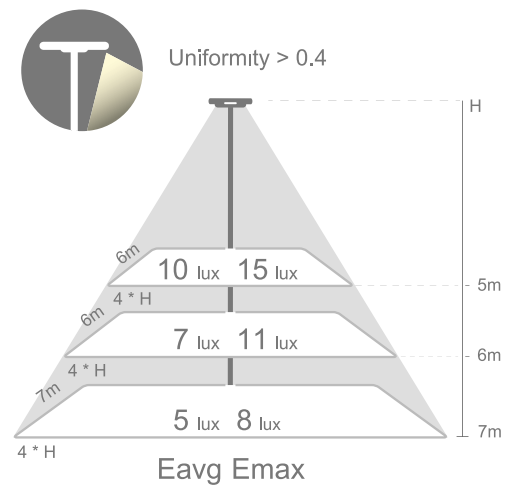

\*E & O.E (Errors And Omissions Excepted)

\*Due to the rapid development in LED technology the performance values, power consumption and lumen output levels stated above are subject to change without prior notice.

\*All lumen outputs stated above are based a nominal output that included a 10% light loss, this can vary depending on the optic used.

### Lighting Control:

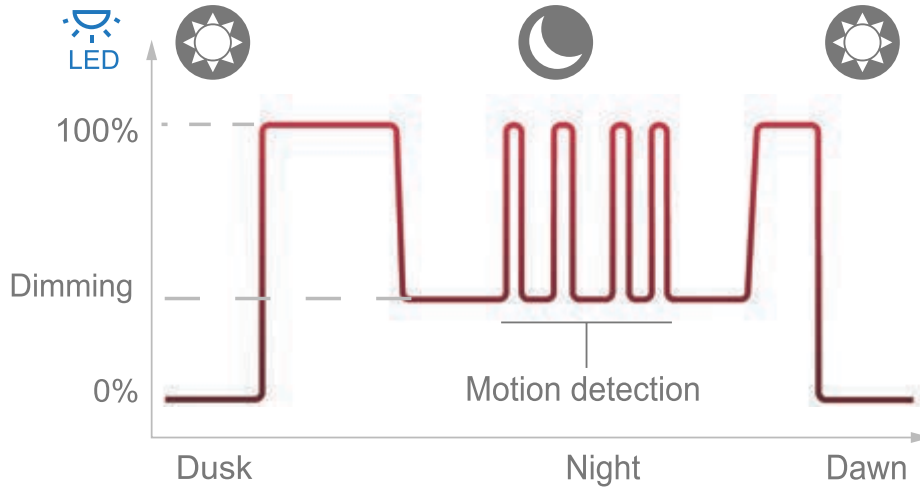

### Dimensions:

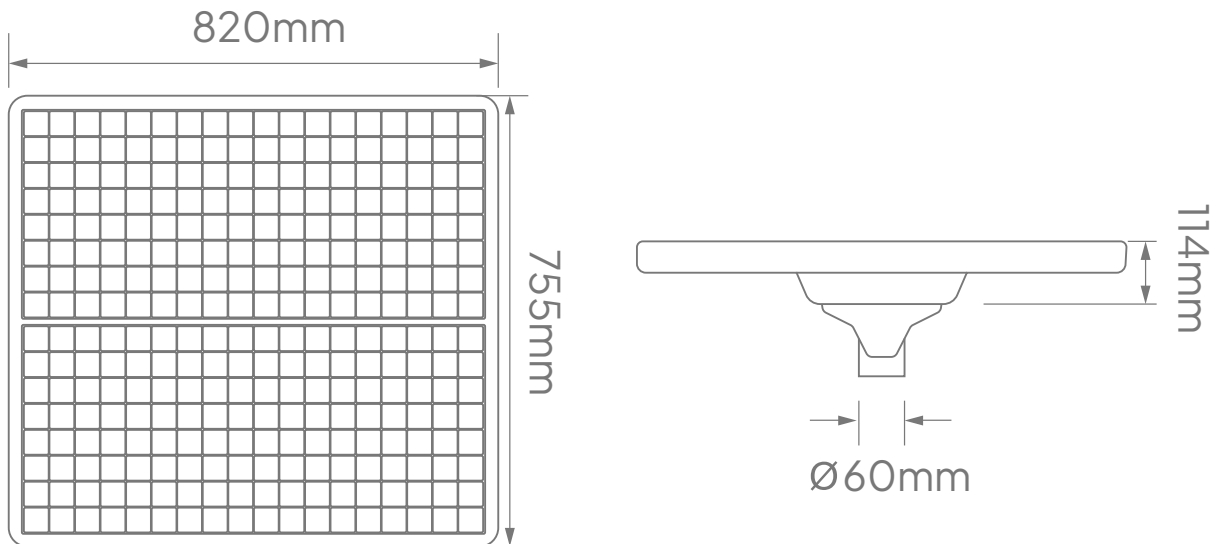

\*E & O.E (Errors And Omissions Excepted)

\*Due to the rapid development in LED technology the performance values, power consumption and lumen output levels stated above are subject to change without prior notice.

\*All lumen outputs stated above are based a nominal output that included a 10% light loss, this can vary depending on the optic used.

# Contact

## Cape Town

1B Hansen Close,  
Richmond Park,  
Cape Town  
T. +27 21 555 0570

## Durban

Unit L, Nandi Park,  
34 Brickworks Way  
Briardene  
T. +27 31 001 2964

## Namibia – Windhoek

Unit 2, Tesoro Building,  
31 TV More Street  
Windhoek  
T. +264 61 40 0339

## Johannesburg

17 Galaxy Road,  
Unit 5A Galaxy Park,  
Linbro Park  
T. +27 11 262 5179

## Port Elizabeth

216 Main Road,  
Walmer  
Port Elizabeth  
T. +27 41 451 4359