

RUBICON
LIGHTING

HUB





Features:

- Efficacy Of Up To 93Lm/W*
- New Gen-6 COB
- Passive Cooling
- Supplied With Protective Glass
- Minimum Lumen Maintenance: 50 000h (L80B10)



Power Supply:	220-240V AC 50 - 60Hz					
Colour Rendering Index:	CRI 80+ _ CRI 90+					
Colour Consistency:	2-Step MacAdam					
Colour Temperature: (Kelvin / CCT)	<input type="radio"/> 2700K <input type="radio"/> 3500K <input type="radio"/> 5000K <input type="radio"/> 3000K <input type="radio"/> 4000K					
Beam Angle:	15° _ 20° _ 30° _ 50°					
Installation Type:	3-Phase Track					
Ingress Protection:	IP23					
Luminaire Colour:	<input type="radio"/> White <input checked="" type="radio"/> Black <input type="radio"/> Custom Colours Available On Request					
Material:	Housing - Powder Coated Die-Cast Aluminium					
	Dimensions		Wattage (System)	CRI	Kelvin	Luminous Flux (Effective)
	100mm x 125mm	450mA	17W	80+	3000K	2475Lm*
	100mm x 125mm	450mA	17W	90+	4000K	2150Lm*
	100mm x 125mm	900mA	35W	80+	3000K	4425Lm*
	100mm x 125mm	900mA	35W	90+	4000K	3850Lm*
	100mm x 125mm	1050mA	42W	80+	3000K	4925Lm*
	100mm x 125mm	1050mA	42W	90+	4000K	4300Lm*

Dimensions:

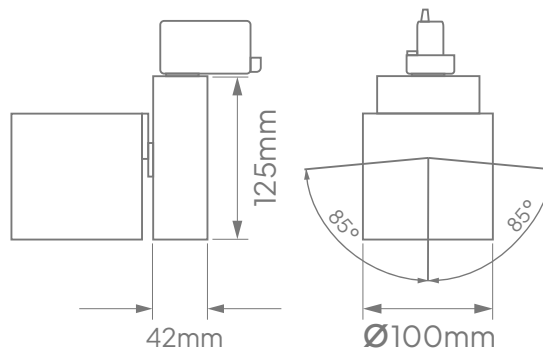

*E & O.E (Errors And Omissions Excepted)

*Due to the rapid development in LED technology the performance values, power consumption and lumen output levels stated above are subject to change without prior notice.

*All lumen outputs stated above are based a nominal output that included a 10% light loss, this can vary depending on the optic used.

Contact

Cape Town

1B Hansen Close,
Richmond Park,
Cape Town
T. +27 21 555 0570

Durban

Unit L, Nandi Park,
34 Brickworks Way
Briardene
T. +27 31 001 2964

Namibia – Windhoek

Unit 2, Tesoro Building,
31 TV More Street
Windhoek
T. +264 61 40 0339

Johannesburg

17 Galaxy Road,
Unit 5A Galaxy Park,
Linbro Park
T. +27 11 262 5179

Port Elizabeth

216 Main Road,
Walmer
Port Elizabeth
T. +27 41 451 4359