

RUBICON
LIGHTING

BRIDGET ROUND





Features:

- Replaceable GU10 Lamp
- Adjustable Tilt
- Housing Warranty (3 Years)



Power Supply:	220 - 240V AC 50 - 60Hz
LED-Module	GU10 LED Compatible 50W (Max)
Installation Type:	Recessed
Ingress Protection:	IP20
Dimensions:	Ø100mm (Ø87mm Cut-Out)
Luminaire Colour:	<input type="radio"/> Sand White <input checked="" type="radio"/> Sand Black
Material:	Housing - Powder coated zinc alloy

Dimensions:

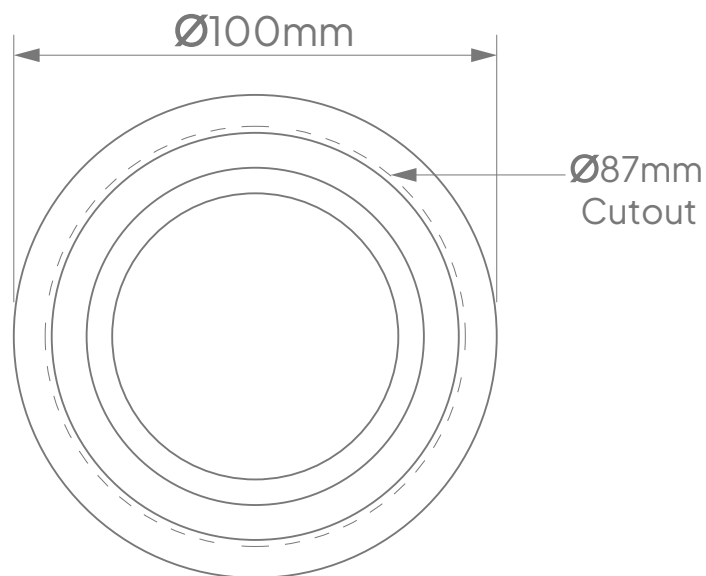

*E & O.E (Errors And Omissions Excepted)
*Subject to change without prior notice.

Contact

Cape Town

1B Hansen Close,
Richmond Park,
Cape Town
T. +27 21 555 0570

Durban

Unit L, Nandi Park,
34 Brickworks Way
Briardene
T. +27 31 001 2964

Namibia – Windhoek

Unit 2, Tesoro Building,
31 TV More Street
Windhoek
T. +264 61 40 0339

Johannesburg

17 Galaxy Road,
Unit 5A Galaxy Park,
Linbro Park
T. +27 11 262 5179

Port Elizabeth

216 Main Road,
Walmer
Port Elizabeth
T. +27 41 451 4359