

**RUBICON**  
LIGHTING

## BRICK PENDANT





**Features:**

- Efficacy Of Up To 106lm/W\*
- High Output “DOB” LED Modules
- Decorative / Architectural Suspended Area Lighting
- Minimum Lumen Maintenance: 50 000h (L80B10)



<b>Power Supply:</b>	220 - 240V AC   50 - 60Hz				
<b>Operating Temperature Range:</b> (Ta - Ambient)	- 20°C to 35°C				
<b>Colour Rendering Index:</b>	CRI 80+				
<b>Colour Consistency:</b>	3-Step MacAdam				
<b>Colour Temperature:</b> (Kelvin / CCT)	● 4000K				
<b>Installation Type:</b>	Suspension				
<b>Ingress Protection:</b>	IP40				
<b>IK Rating:</b>	IK04				
<b>Luminaire Colour:</b>	● Black				
<b>Material:</b>	Housing - Fitting frame construction CNC laser cut and co <sup>2</sup> welded mild steel finished in a durable outdoor epoxy powder coating Diffuser - Vacuum Formed PETG				
	<b>Dimensions</b>	<b>Wattage (System)</b>	<b>CRI</b>	<b>Kelvin</b>	<b>Luminous Flux (Effective)</b>
	151mm x 98mm x 98mm	15W	80+	4000K	1600Lm*

**Dimensions:**

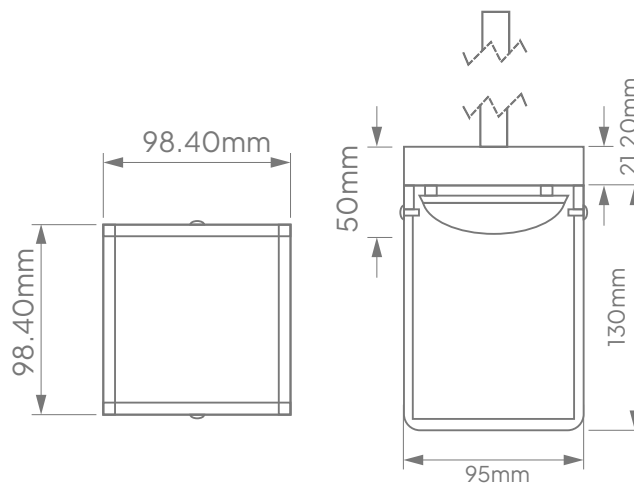

\*E & O.E (Errors And Omissions Excepted )

\*Due to the rapid development in LED technology the performance values, power consumption and lumen output levels stated above are subject to change without prior notice.

\*All lumen outputs stated above are based a nominal output that included a 10% light loss, this can vary depending on the optic used.

# Contact

## Cape Town

1B Hansen Close,  
Richmond Park,  
Cape Town  
T. +27 21 555 0570

## Durban

Unit L, Nandi Park,  
34 Brickworks Way  
Briardene  
T. +27 31 001 2964

## Namibia – Windhoek

Unit 2, Tesoro Building,  
31 TV More Street  
Windhoek  
T. +264 61 40 0339

## Johannesburg

17 Galaxy Road,  
Unit 5A Galaxy Park,  
Linbro Park  
T. +27 11 262 5179

## Port Elizabeth

216 Main Road,  
Walmer  
Port Elizabeth  
T. +27 41 451 4359