



Solenoid valve 2/2 way N.C. Direct acting

21AN2K0T12-XC

PRESENTATION:

Direct acting S.V. for interception of fluids compatible with the construction materials.

Minimum operational pressure is not required.

The materials used and the tests carried out ensure maximum reliability and duration.

USE: Automation

PIPES: 1/4 NPT

COILS:

8W - Ø 13	
BDA - BSA	155°C (class F)
BDV	180°C (class H)
12W - Ø 13	
UDA	155°C (class F)
UDV	180°C (class H)

Max. allowable pressure (PS) 100 bar

Ambient temperature:

See coils catalogue page for its compatibility.



Gaskets	Temperature		Medium
	-40°C	+180°C	
T=PTFE (polytetrafluorethylen)			Air, water

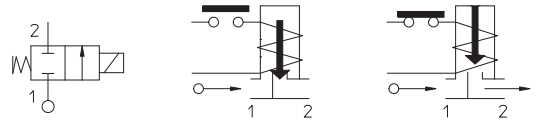

Pipe ANSI/ASME BI.20.1	Code	Max viscosity		Ø mm	Kv l/mn	Power watt	Pressure		
		cSt	°E				min bar	M.O.P.D.	
								AC bar	DC bar
1/4 NPT	21AN2K0T12-XC	12	~ 2	1,2	1	8 12	0 0	100 100	90 100

Note.

Available on request and with minimum quantities.

The "ODE" reserves the right to carry out technical and aesthetic modifications without prior notice.

MATERIALS:

Body	Brass - UNI EN 12165 CW617N
Armature tube	Stainless steel AISI series 300
Fixed core	Stainless steel AISI series 400
Plunger	Stainless steel AISI series 400
Phase displacement ring	Copper - Cu 99,9%
Spring	Stainless steel AISI series 300
Main seal	T=PTFE
Orifice: Insert slot	Stainless steel AISI series 300

On request:

Connector	Pg 9 o Pg 11
Connector conformity	ISO 4400

FEATURES:

Electrical conformity	IEC 335
Protection degree	IP 65 EN 60529 (DIN 40050) with coil fitted by connector..

SPARE PARTS:

- Coil:**
See coils list
- Complete plunger:**
Code R450897
- Complete armature tube:**
Code R450606

KIT:

KT130K730-AP =2+3

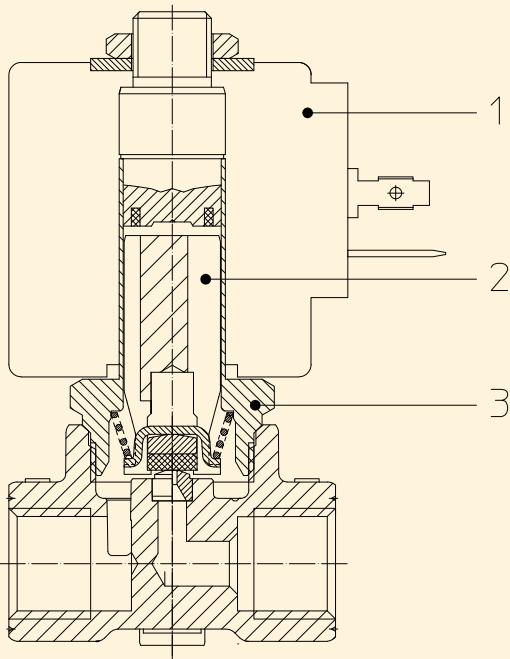

DIMENSIONS:

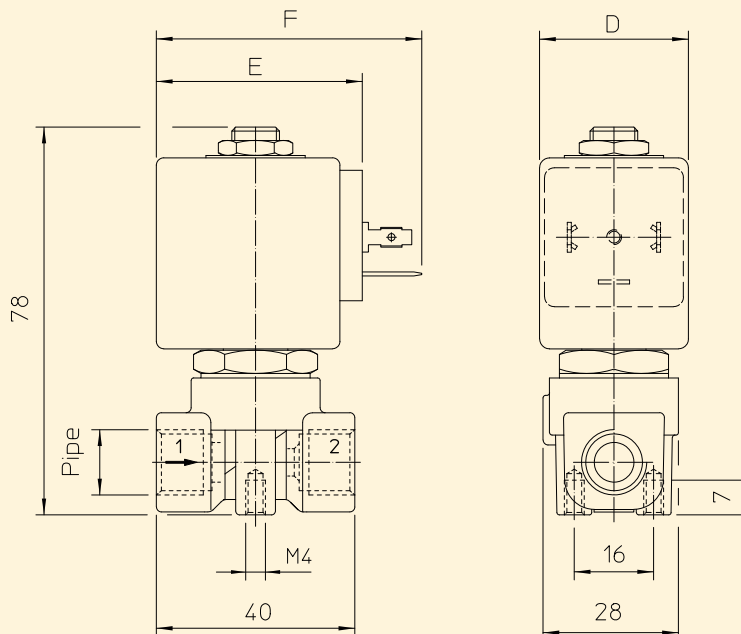

COIL TYPE	POWER ABSORPTION			DIMENSIONS			
	W =	Hold VA ~	Inrush VA ~	D mm	E mm	F mm	G mm
B	8	14,5	25	30	42	54	20,5
U	12	23	35	36	48	60	23,5