

# Fuel Level Sender Installation Instructions



USE IS RESTRICTED TO 12 VOLT NEGATIVE GROUND ELECTRICAL SYSTEMS ONLY.  
FOR WIRING INSTRUCTIONS, REFER TO THE INSTRUCTIONS THAT CAME WITH YOUR FUEL GAUGE

Optional Materials May Be Required for Installation:

Bolt-on Installation Kit (optional) P/N 226 451

**CAUTION:** Read these instructions thoroughly before installing sender. Do not deviate from assembly or wiring instructions. Always disconnect battery ground before making any electrical connections.

### Fuel Level Sender Installation:

Refer to the VDO catalog for matching fuel gauges. The unit can be adjusted to read accurately in tanks from 6" to 21" deep.

1. Measure the depth of your fuel tank. Locate this dimension in Column "A" of Table 1. Column "B" shows the length from the underside of the sender flange to the center of the float arm pivot.

Column "C" shows the distance from the center of the float arm pivot to the center of the float ball. For example, a tank 12" deep would require sender dimensions of 6" from the flange to the pivot, and 7.8" from the pivot to the float.

1. Remove nut "a", washer "b", and ring terminal "c" underside of the mounting flange.
2. Remove the two screws marked "d" and discard.
3. Remove the two screws marked "e" from the Plastic housing and save for later use.
4. Carefully remove bracket "f" from the plastic Housing and discard. Replace plastic housing on Bracket "g" and loosely re-install the two screws marked "e" into the housing
5. Slide the housing up or down until the proper Dimension from the Table 1 is reached, then Tighten the screws "e" securely.
6. Replace the ring terminal and its hardware.
7. Proceed to section IV.

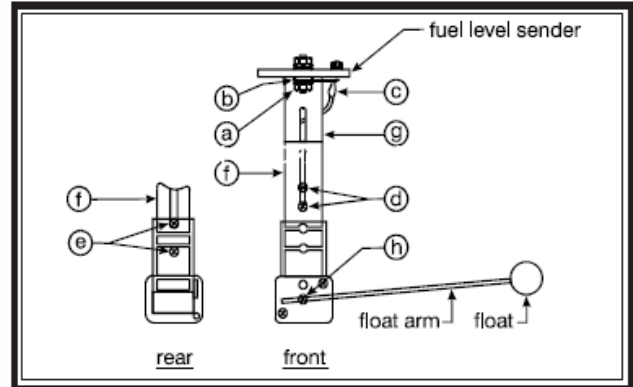

Diagram B  
Parts of the Fuel Level Sender Unit to be Adjusted

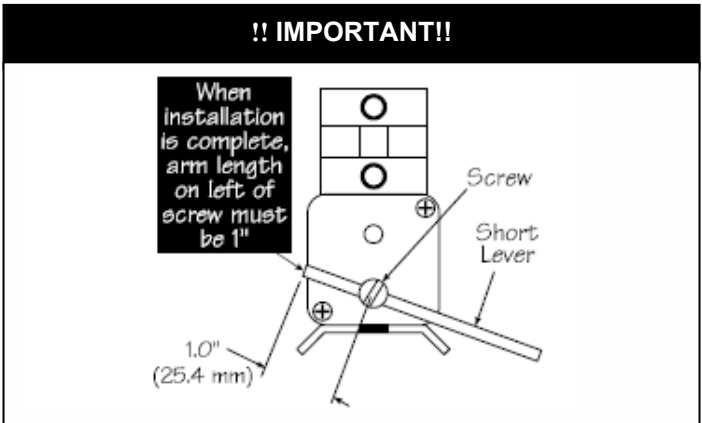

Diagram C

**CAUTION:** When attaching the float arm to the sender body, make sure the float ball is to the right side as you face the unit, as shown in Diagram B. If you attach the float arm to the left of the sender body, or backwards, the fuel gauge will read "FULL" when the tank is actually

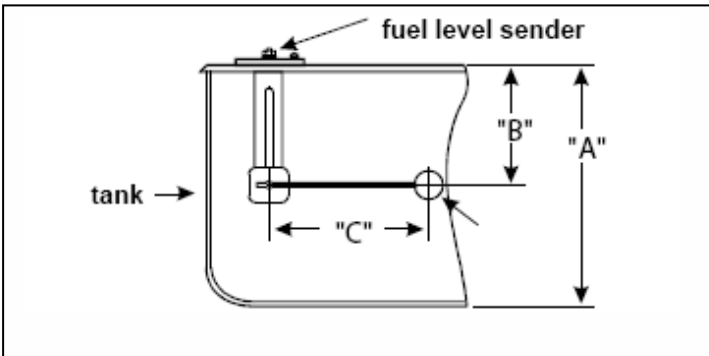

Diagram A  
Measurements Needed to Make Proper Adjustments

**TABLE 1 (dimensions in inches)**

A	B	C	A	B	C	A	B	C
6.00	3.00	3.50	12.00	6.00	7.80	18.00	9.00	12.00
6.50	3.25	3.80	12.50	6.25	8.10	18.50	9.25	12.30
7.00	3.50	4.20	13.00	6.50	8.50	19.00	9.50	12.60
7.50	3.75	4.50	13.50	6.75	8.90	19.50	9.75	12.90
8.00	4.00	4.90	14.00	7.00	9.30	20.00	10.00	13.40
8.50	4.25	5.30	14.50	7.25	9.60	20.50	10.25	13.80
9.00	4.50	5.60	15.00	7.50	10.00	21.00	10.50	14.20
9.50	4.75	6.00	15.50	7.75	10.40			
10.00	5.00	6.40	16.00	8.00	10.70			
10.50	5.25	6.70	16.50	8.25	11.00			
11.00	5.50	7.10	17.00	8.50	11.40			
11.50	5.75	7.10	17.50	8.75	11.80			

III. For tank depths of 16" to 23", no disassembly of the send bracket is necessary.

- .1. Remove nut "a", washer "b", and ring terminal "c" from the underside of the mounting flange.
- .2. Loosen the two screws marked "d", Adjust the plastic housing up or down until the proper dimension from Tables 1 is obtained, and then re-tighten the screws securely. DO NOT over tighten.
- .3. Re-install the ring terminal and its hardware. Again, tighten the hardware securely but DO NOT over tighten.

IV. Refer to Diagram A and C to install the float assembly, Loosen the screw marked "h" remove the short piece of rod, And discard it. Insert the float rod until the proper length-the "C" length from Table 1 – is met, then tighten screw "h" securely. Carefully cut off any excess rod with a bolt cutter or similar tool, taking care not to damage the assembly.

NOTE: Make sure the float is installed as show in Diagram B. Remember, if it is installed backwards, the fuel gauge will indicate "FULL" when the tank is actually empty, and vice-versa. Be sure to leave 1" in the short side of the arm.

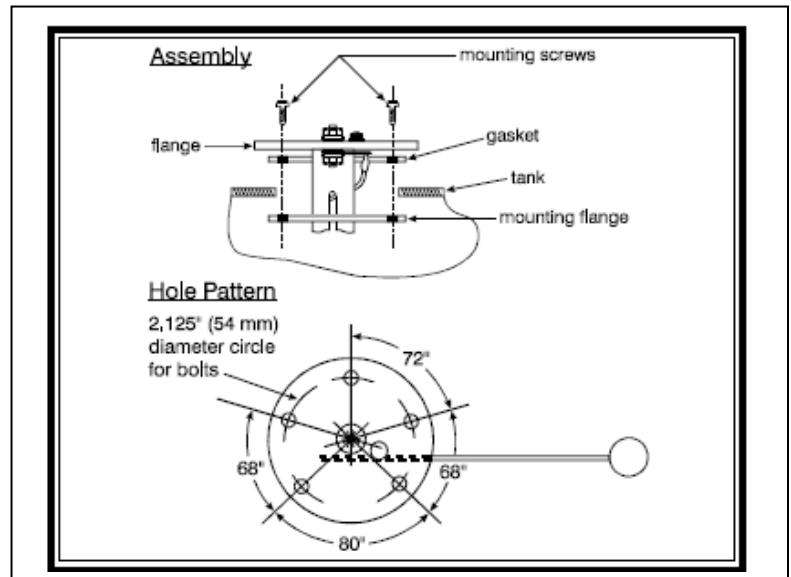

Diagram D  
Fuel Sender Assembly and Hole Pattern Dimension

**CAUTION:** Before drilling any holes into the tank, place the sender assembly on top of the tank to judge the proper hole placement-one that will allow the float arm clearance inside the tank.

**SAFETY PRECAUTION:** When making modifications to fuel tanks, it is essential that the tank be removed from the vehicle, and that it is empty, clean and dry. After drilling make sure all chips and other foreign matter have been removed from the tank. Clean the tank thoroughly.

V. Refer to Diagram D for installation of the fuel sender assembly into the tank. The sender flange is designed to fit a standard SAE hole pattern. Make certain float arm has a clear field of motion before tightened screws in the flange assembly. If no holes exist in the tank refer to section VI.

VI. Refer to Diagram E. If no holes exist in the fuel tank and you have the optional mounting kit (226-551) cut a 2.332" (59mm) hole in the top of the tank.

1. Pick up fuel sender and slide the rubber gasket up to the bottom of the fuel sender flange. Next, slide the second flange over fuel sender to bottom of rubber gasket. Align the pre-drilled holes in the mounting flange and rubber gasket with those in fuel sender flange. Use 1" screw to connect top flange, gasket, and mounting flange. Leaving mounting flange as loose as possible.
2. Slip the fuel sender assembly into the 2.322" (59mm) hole in the tank, turning assembly until it goes into the tank.
3. Make certain float arm has a clear field of motion before tightening screws in flange assembly.

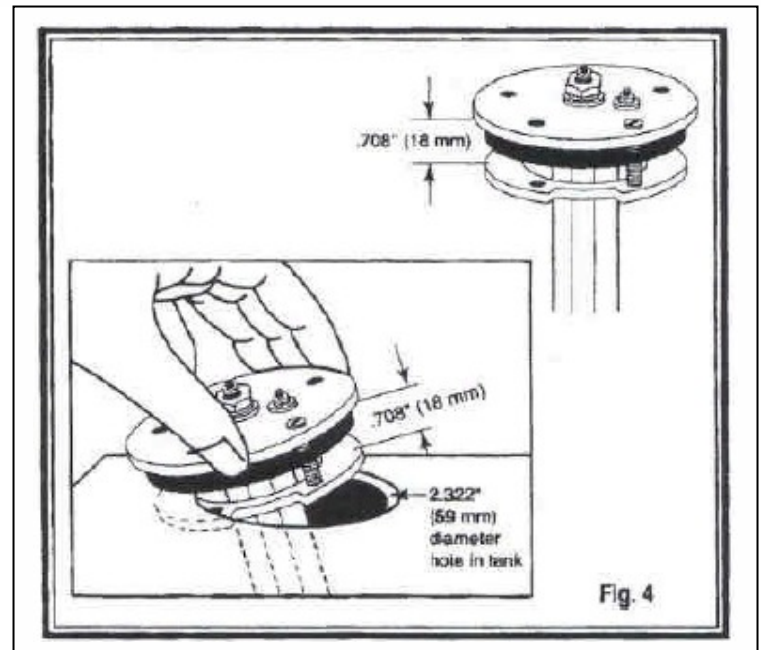

Diagram E  
Optional Mounting Kit Part Number 226-451

Merchandise warranted against defects in factory workmanship and materials for a period of 24 months after purchase. This warranty applies to the first retail purchaser and covers only those products exposed to normal use or service. Provisions of this warranty shall not apply to a VDO product used for a purpose for which it is not designed, or which has been altered in any way that would be detrimental to the performance or life of the product, or misapplication, misuse, negligence or accident. On any VDO part or VDO product found to be defective after examination by manufacturer, manufacturer will only repair or replace the merchandise through the original selling dealer. Manufacturer assumes no responsibility for diagnosis, removal and/or installation labor, loss of vehicle use, loss of time, inconvenience or any other consequential expenses. The warranties herein are in lieu of any other expressed or implied warranties, including any implied warranty of merchantability of fitness, and any other obligation on the part of manufacturer, or selling dealer.

(NOTE: This is a "Limited Warranty" as defined by the Magnuson-Moss Warranty Act of 1975.)