

Montageanleitung
 Assembly Instructions
 Instructions de montage
 Istruzione di montaggio
 Монтажная инструкция
 (электрическая модель)

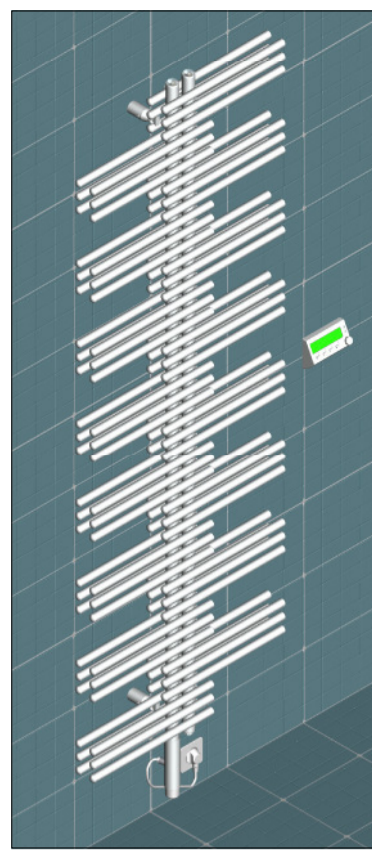
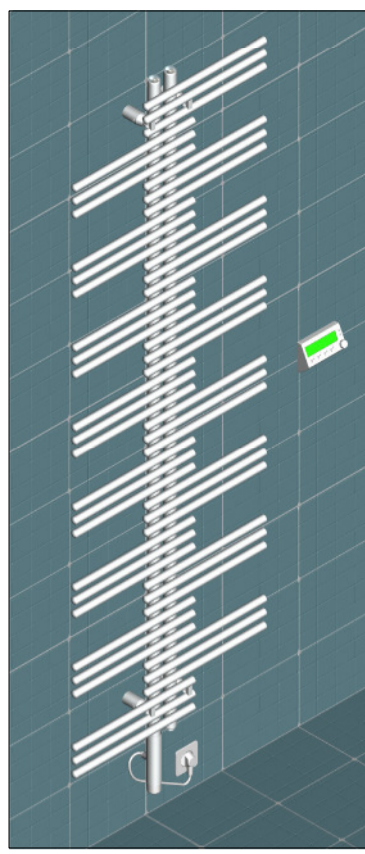

Achtung:
 Bitte das beigefügte Instruktionsblatt der IRVAR Elektro-Heizpatrone beachten.

Attention:
 Veuillez svp. observer la fiche d'instruction de la résistance électrique IRVAR.

Attention:
 Please observe the installation instructions of the immersion heater type IRVAR supplied with this unit.

Attenzione:
 Vedasi istruzione di servizio per resistenza elettrica IRVAR.

Внимание!
 Пожалуйста, обратите внимание на прилагаемую инструкцию для погружного электронагревательного элемента IRVAR.

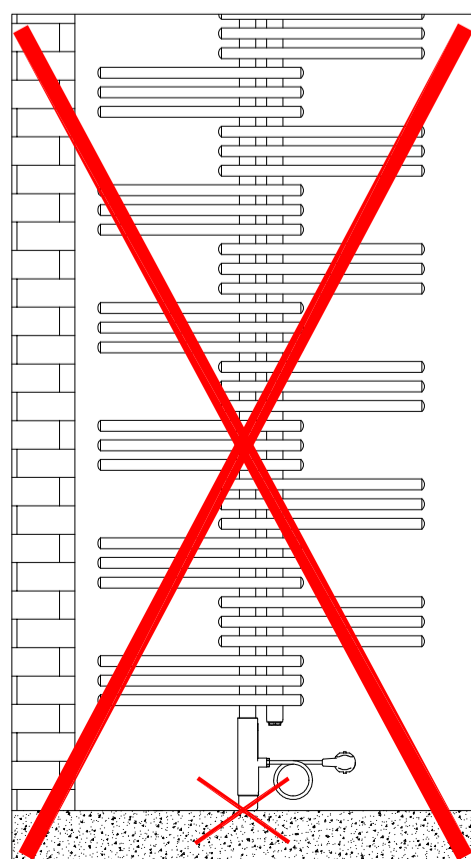
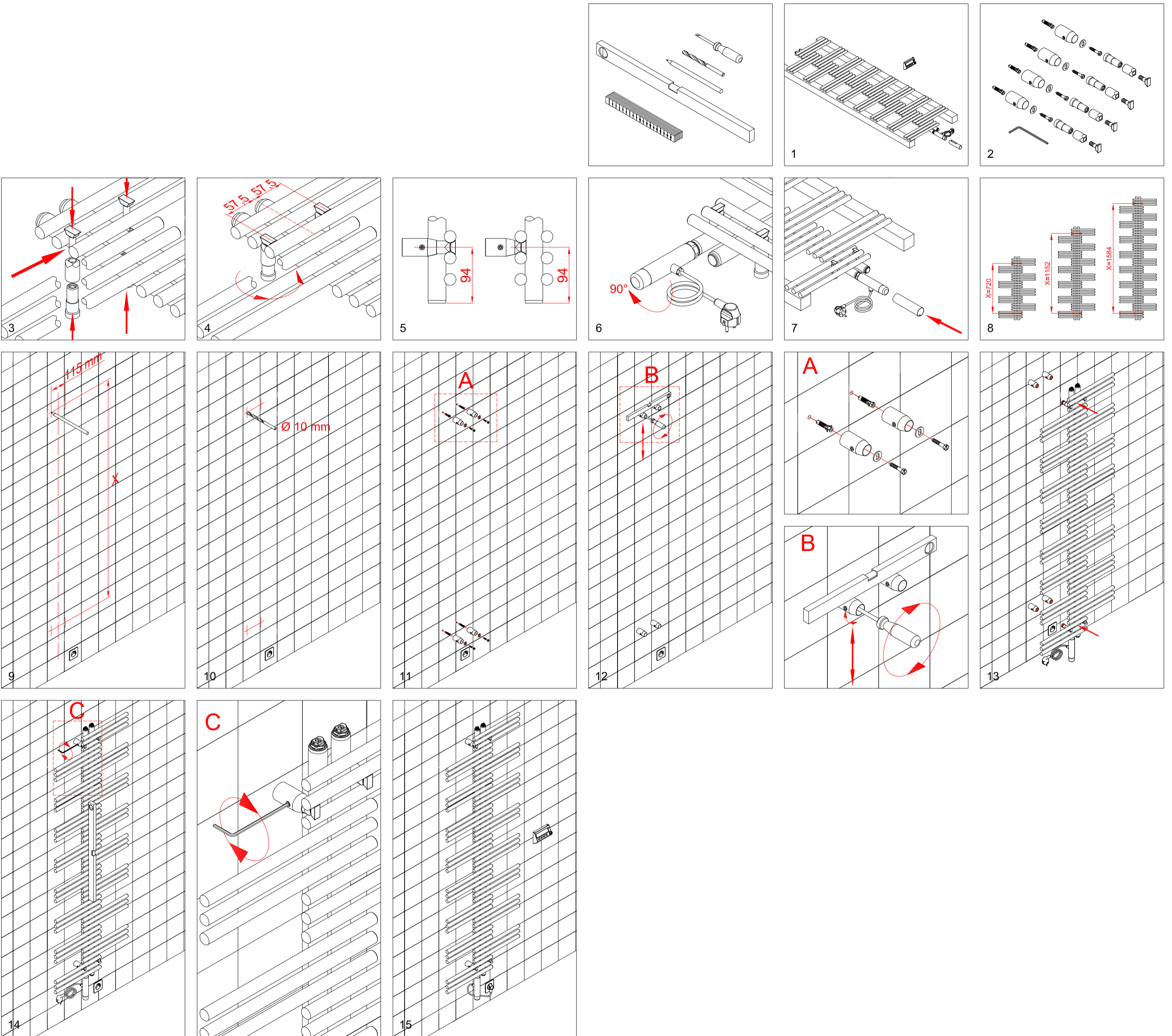

Montageanleitung

Assembly Instructions

Instructions de montage

Istruzione di montaggio

Монтажная инструкция

(водяная или комбинированная модель)

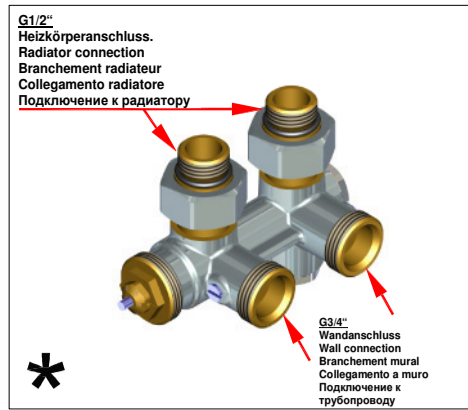
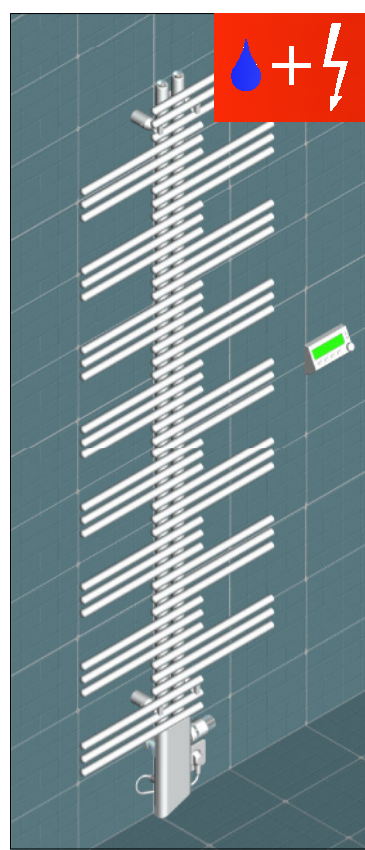
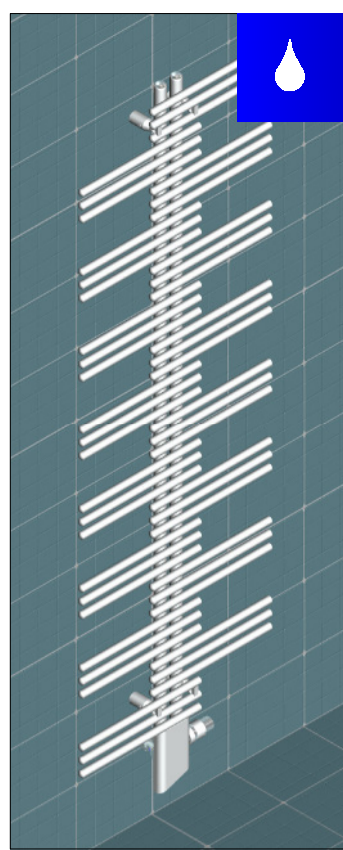

*узел подключения (заказывается дополнительно)

Achtung:

Wird der Design-Heizkörper zusätzlich mit einer IRVAR Elektro-Heizpatrone ausgerüstet, ist das beigefügte Instruktionsblatt der IRVAR Elektro-Heizpatrone zu beachten.

Attention:

If this towel radiator is to be installed with an immersion heater type IRVAR, then please observe the installation instructions supplied with the immersion heater.

Attention:

Si le radiateur est équipé d'une résistance électrique IRVAR, la fiche d'instruction en annexe est à observer.

Attenzione:

Se lo scaldasalvietta sarà montato di resistenza elettrica IRVAR, vedasi in allegato istruzione di servizio.

Внимание!

Если радиатор дополнительно оснащен погружным электронагревательным элементом IRVAR, обратит внимание на прилагаемую инструкцию для погружного электронагревательного элемента IRVAR.

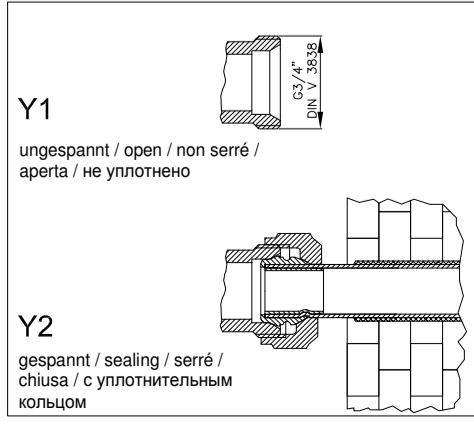
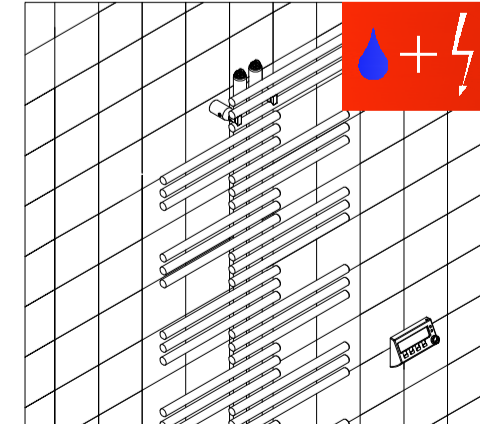
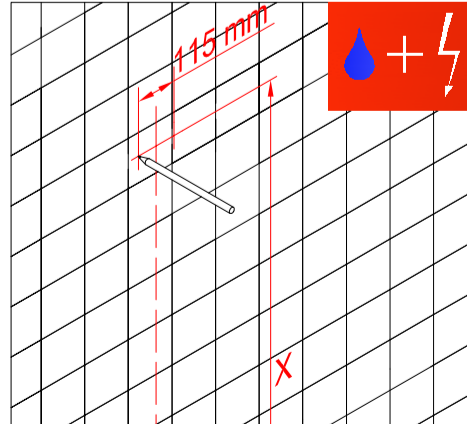
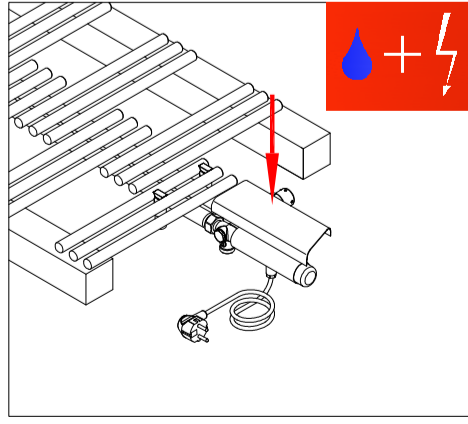
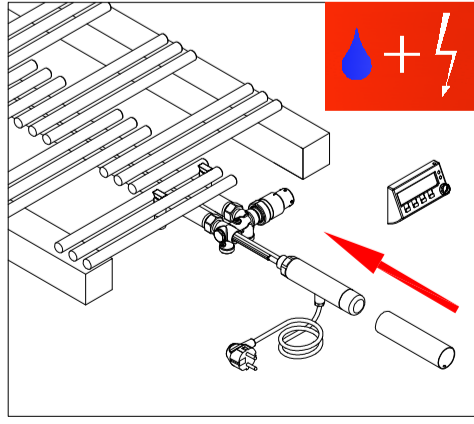
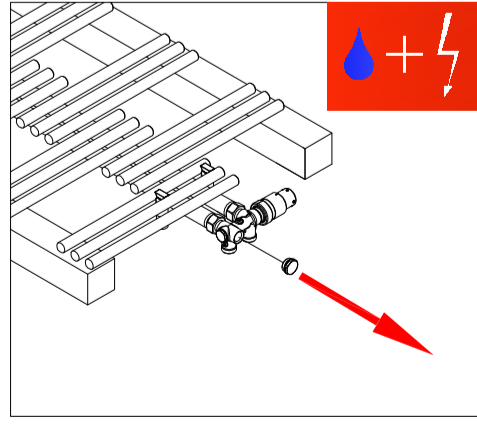
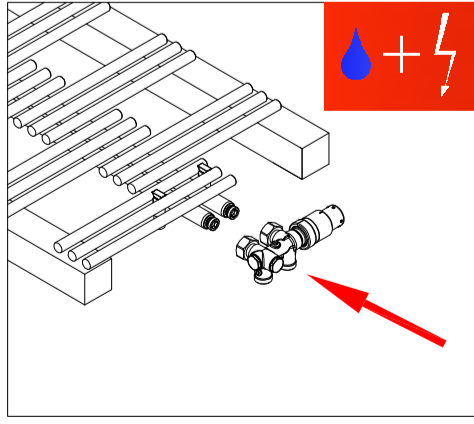
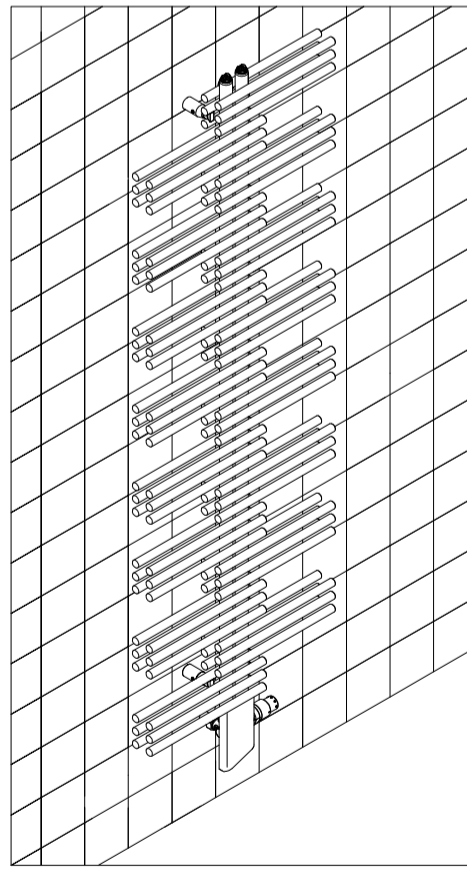
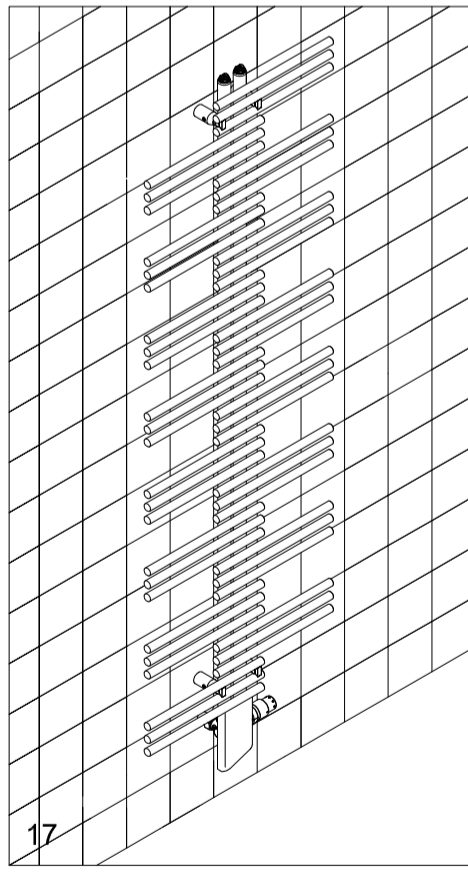
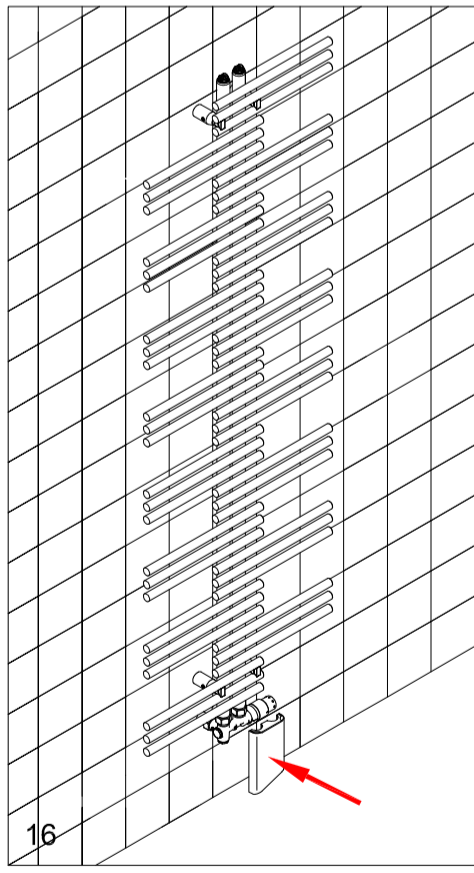
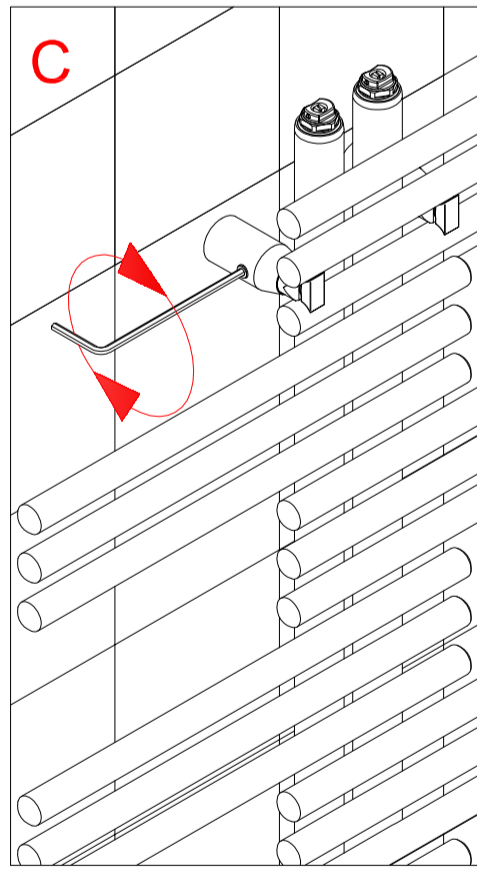
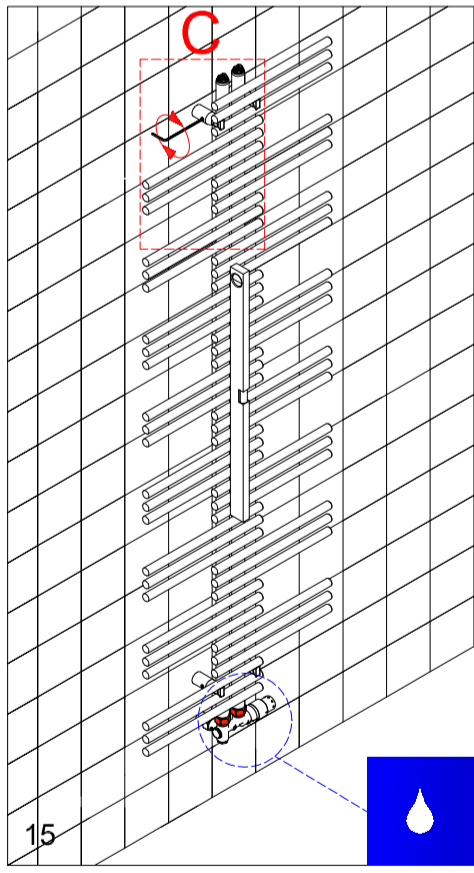
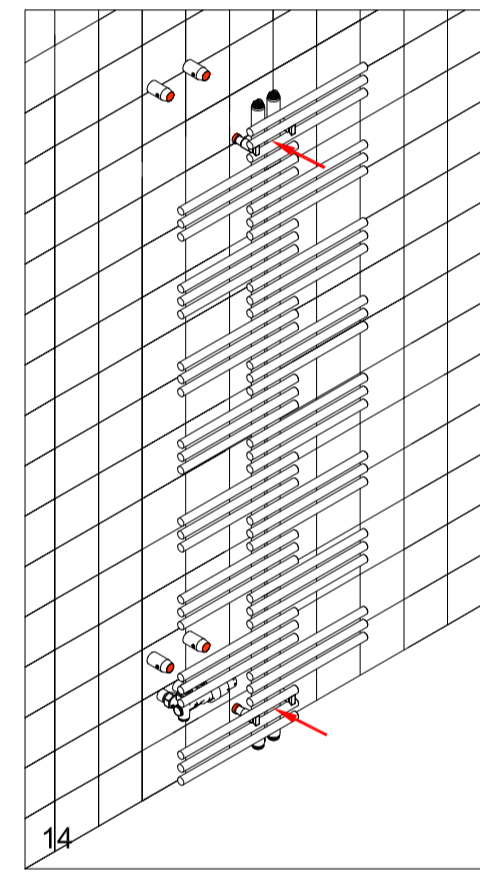
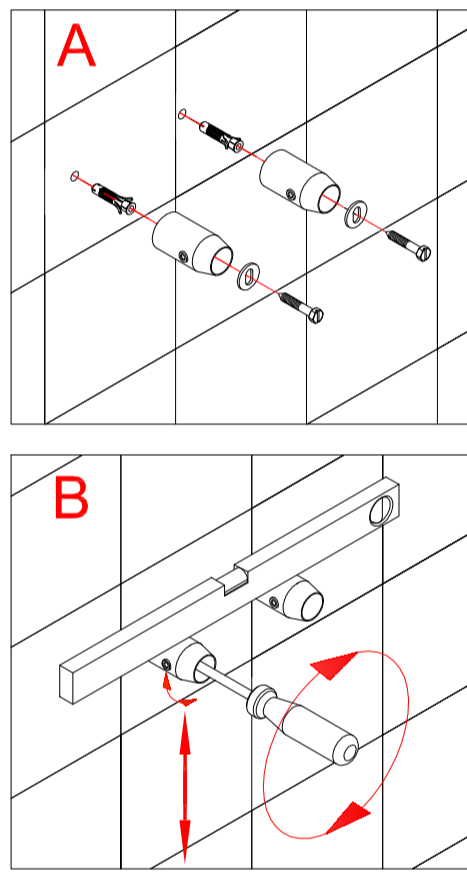
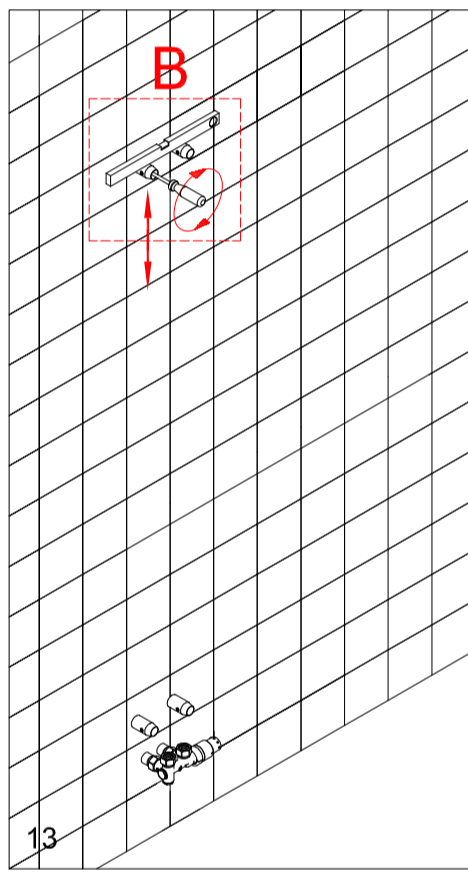
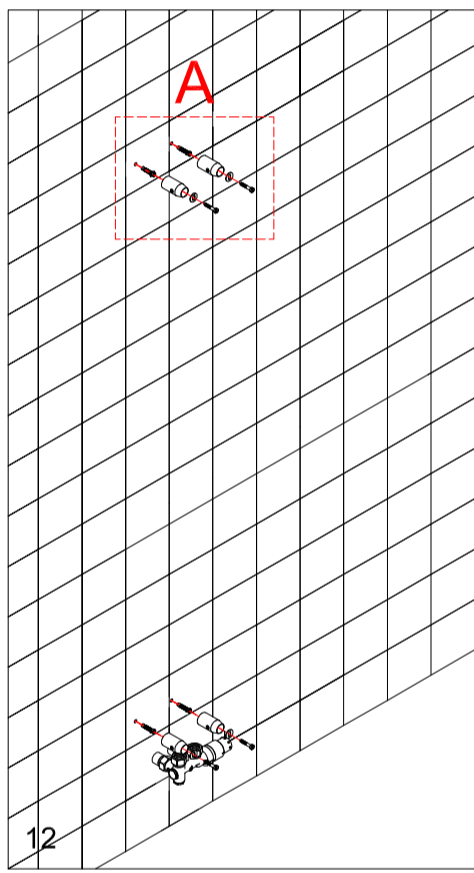
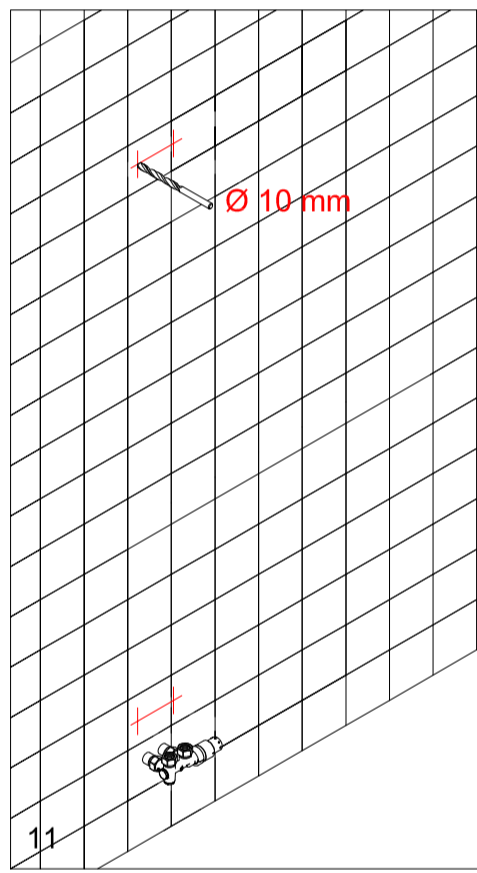
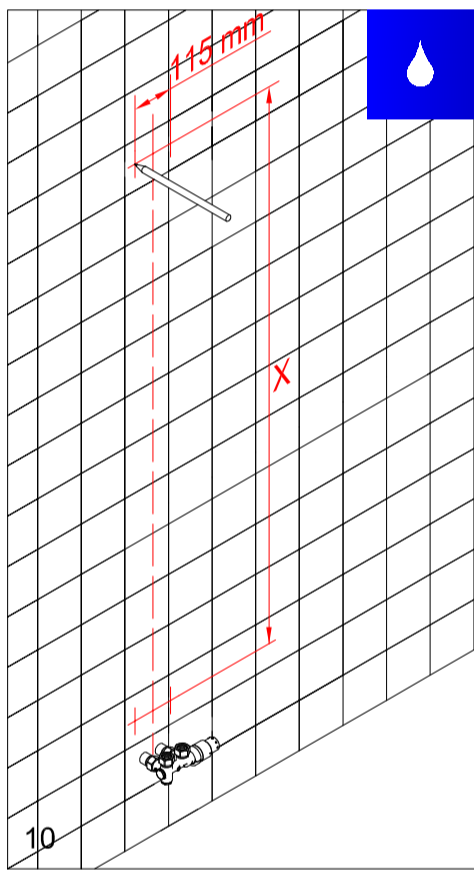
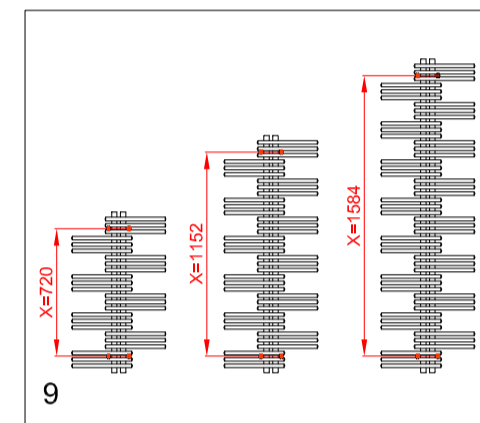
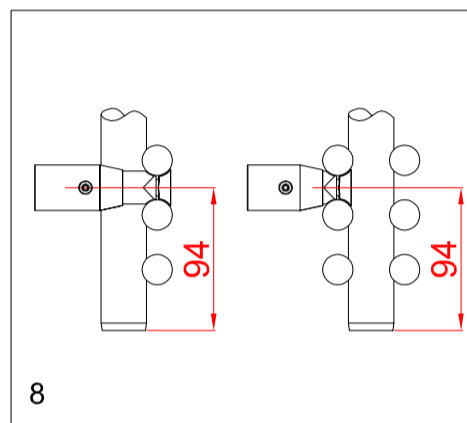
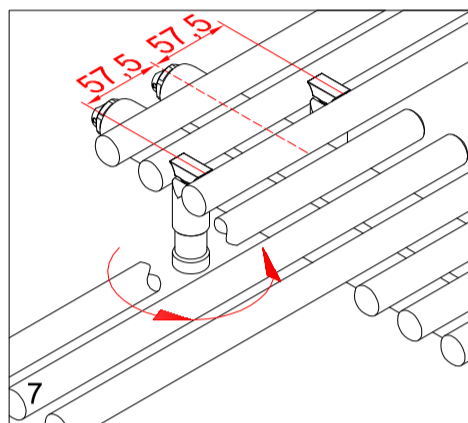
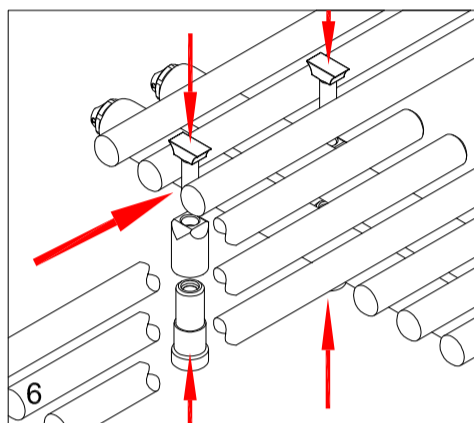
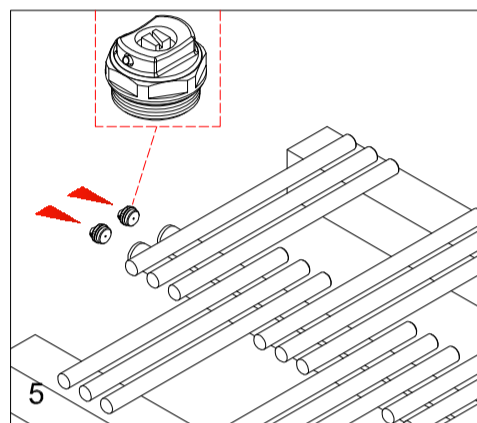
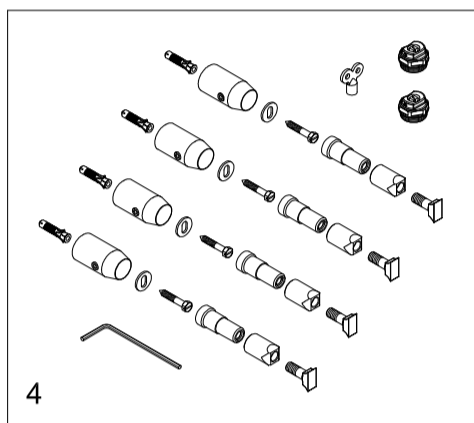
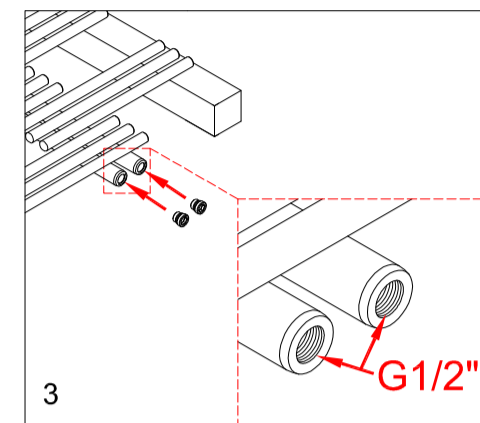
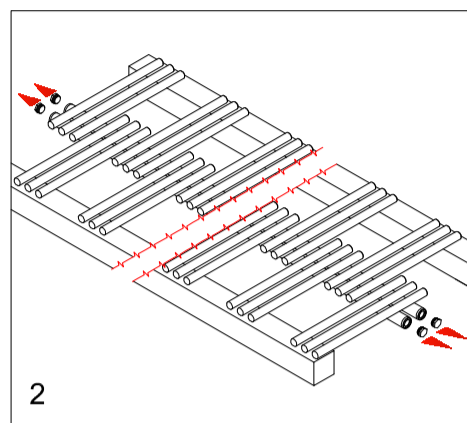
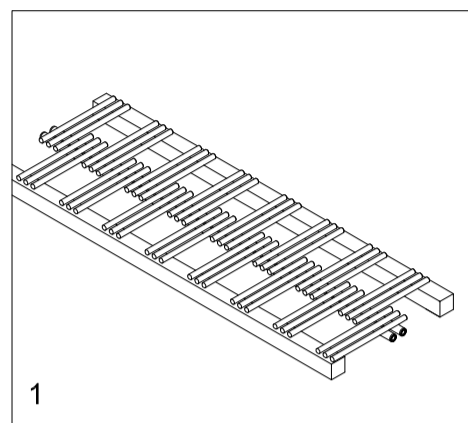
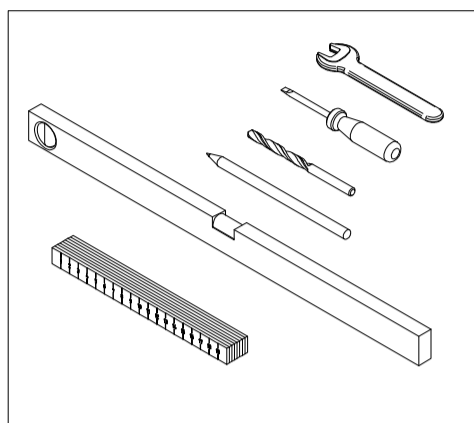
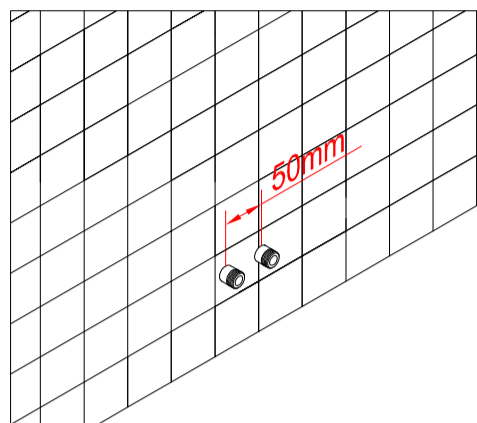

Es ist darauf zu achten, dass die bauseitig zu montierende Verbindung mit den unter Bild Y1 angegebenen Konturmaßen der eingeschweißten Garnituren / beigelegten Armaturen korrespondiert. Als Anschluss von Heizkörperarmaturen empfehlen wir Fabrikate der Firma Oventrop und Heimeier mit AG 3/4". Bei Rohrdimensionen kleiner als 18 mm AD müssen Klemmringe mit Bezugskanten eingesetzt werden (Bild Y2).

It is important that the valve/block connections (supplied by others) correspond to the supplied 3/4" Mi thread. Please refer to figure Y1 for correct installation details. We recommend that the connection valves or blocks from either Oventrop or Heimeier with 3/4" FI are used. When using connection tubes smaller than 18 mm OD, a suitable reducer must be used. Please see figure Y2.

Attention: le raccordement qui est à mettre en place par l'installateur doit correspondre aux cotes dimensionnelles indiquées (image Y1) de la robinetterie soudeée ou fournie par nous. Pour le raccordement de la robinetterie nous conseillons des pièces des fournisseurs Oventrop ou Heimeier avec filetage extérieur 3/4". Pour un diamètre de tube inférieur à 18 mm, des bagues de serrage avec butée doivent être utilisées (image Y2).

Attenzione: Nel caso di acquisto di un nostro prodotto fornito già completo di allacciamento predisposto per il raccordo di collegamento all'impianto, o in forma di valvola, è importante che i tubi di collegamento corrispondano alle misure indicate nella figura Y1. In caso si utilizzino tubi con diametro esterno inferiore a 18 mm è obbligatorio applicare i raccordi di riduzione compatibili. Come raccordi consigliamo i prodotti Oventrop o Heimeier.

Обратите внимание на то, чтобы присоединительные фитинги соответствовали установленным размерам запорных и регулирующих вентилях (Рис. Y1). Для присоединения мы рекомендуем вентиля компании Oventrop и компании Heimeier размером DN 15 G3/4" (заказываются дополнительно).

Присоединительные трубы с наружным диаметром менее 18 мм возможно использовать только с уплотнительным кольцом (Рис. Y2)

