

Item	Description
1	Spanner
2	Plug access tool
3	Waste with overflow control
4	Sponge washer
5	Rubber washer
6	Rubber washer
7	Brass nut
8	Flat washer
9	Siphon/trap
10	Overflow air valve
11	Flexible pipe
12	Elbow
13	EU to UK Adapter
14	Silicone cover
15	Protection Cap



EN: Must use a ventilated waste system and ensure the bath is not fully sealed to allow an air intake to the air admittance valve (part 10).

ES: Deben utilizarse un sistema de desagüe ventilada y asegúrense que la bañera no está completamente sellada al suelo para permitir una entrada de aire a la válvula de aire (parte 10).

DE: Muss an ein belüftetes Abwassersystem angeschlossen sein. Weiterhin darf die Wanne bei der Installation nicht vollständig versiegelt werden, damit eine Luftzufuhr zum Belüftungsventil gewährleistet ist (Teil 10).

IT: Deve essere usato uno scarico ventilato. Assicurarsi che la vasca non sia completamente sigillata perché la valvola d'aspirazione abbia una presa d'aria.

FR: Nécessité d'un circuit sanitaire ventilé et veiller à ce que la baignoire ne soit pas totalement scellée, afin de permettre l'arrivée d'air vers le clapet d'admission d'air.

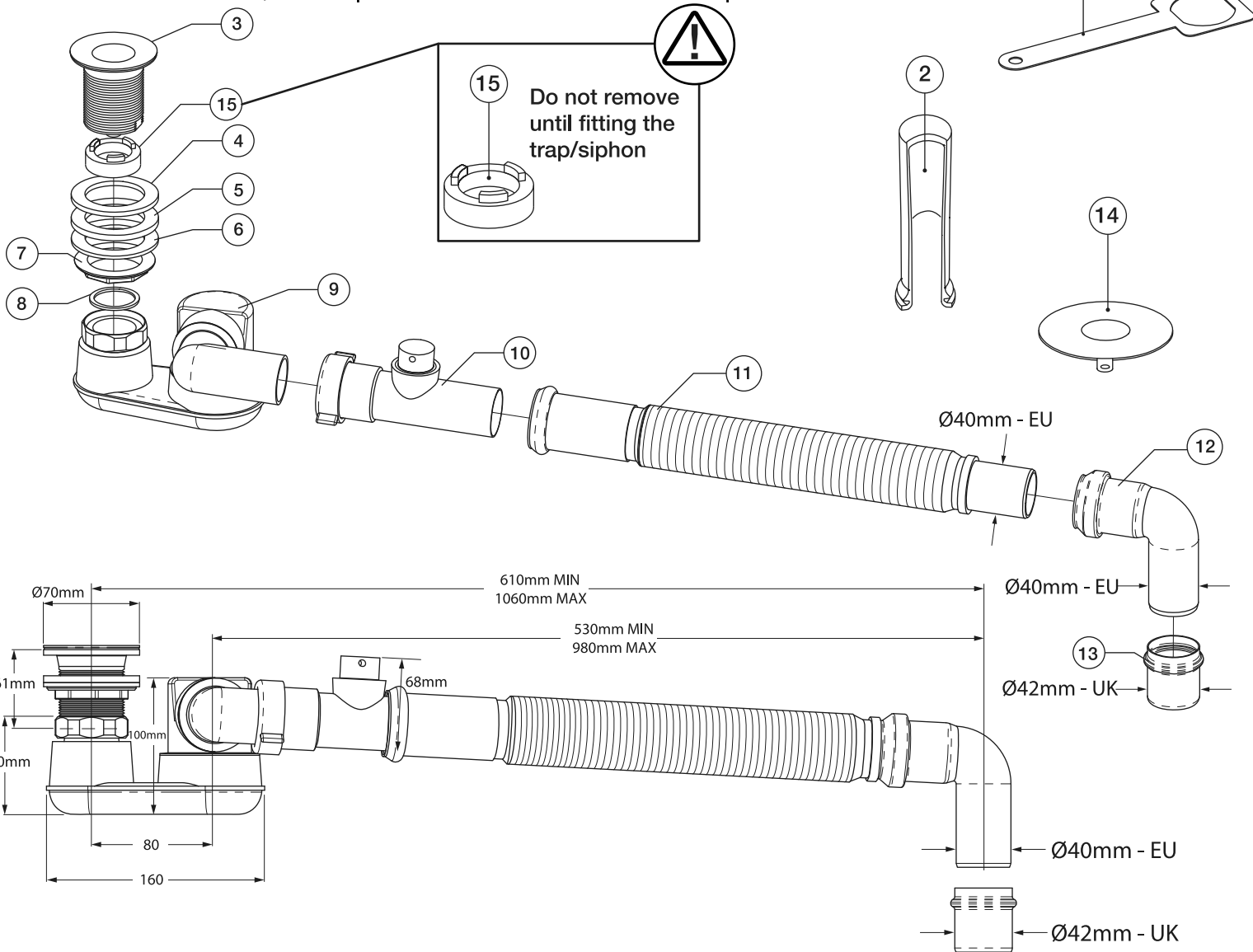

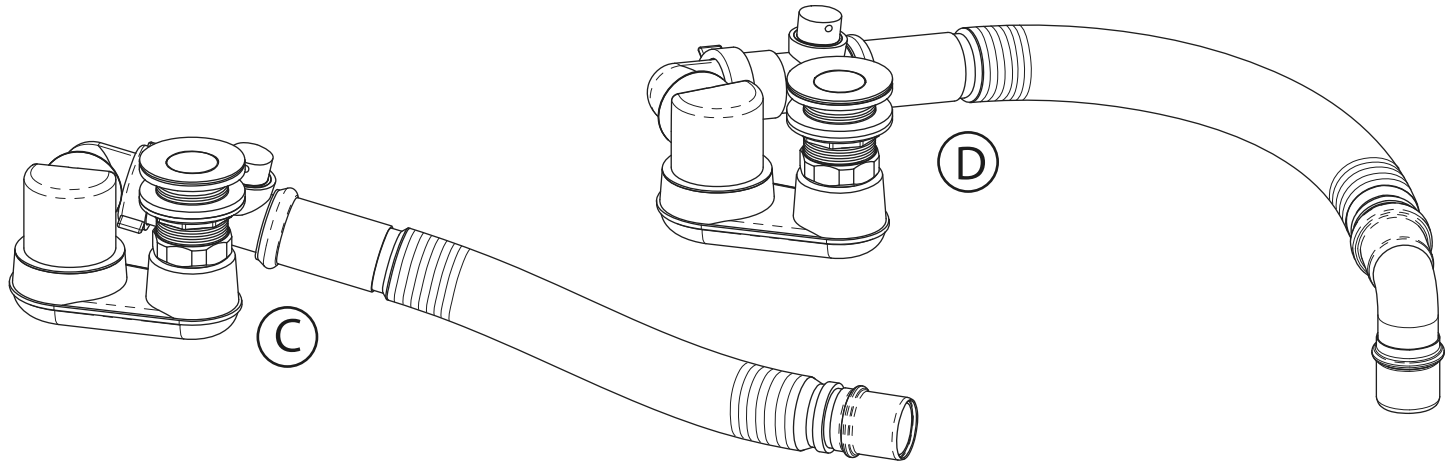
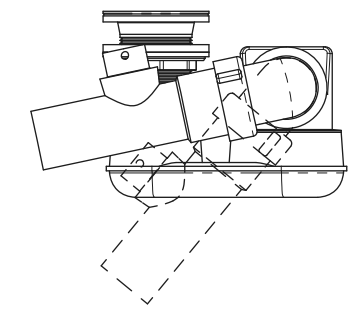
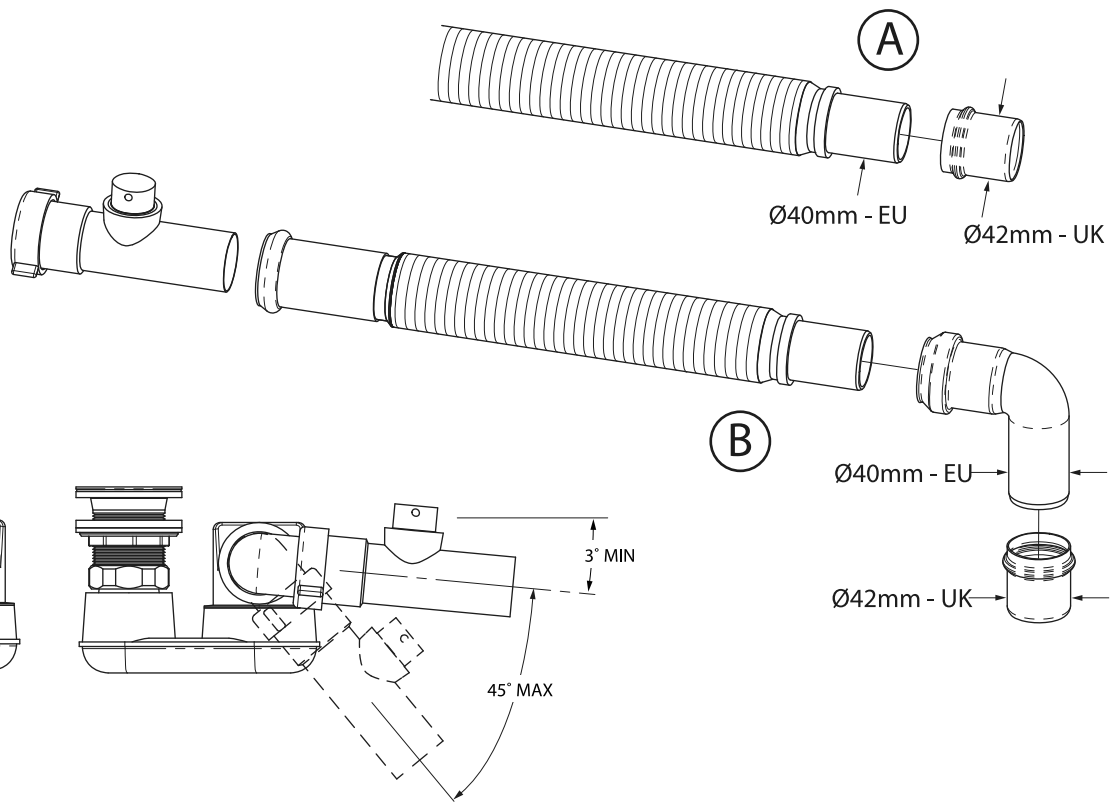
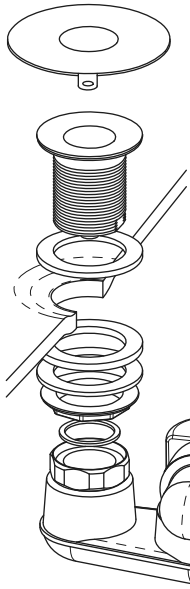
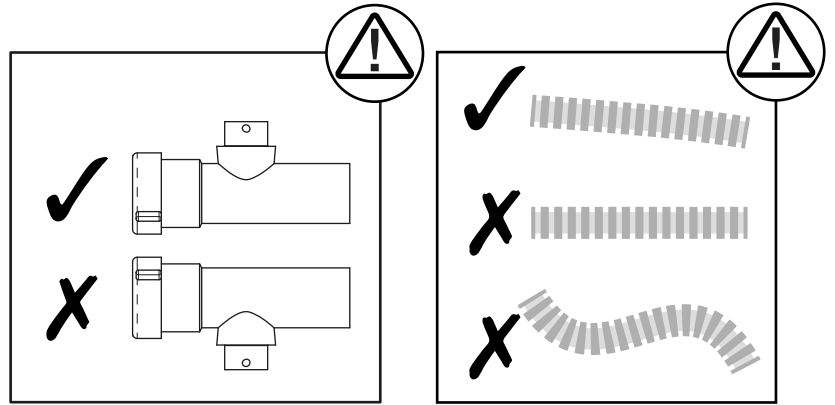

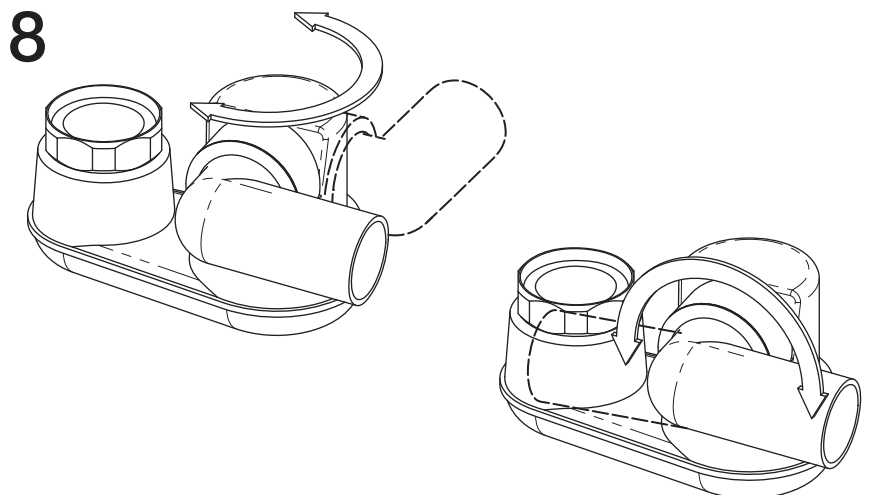
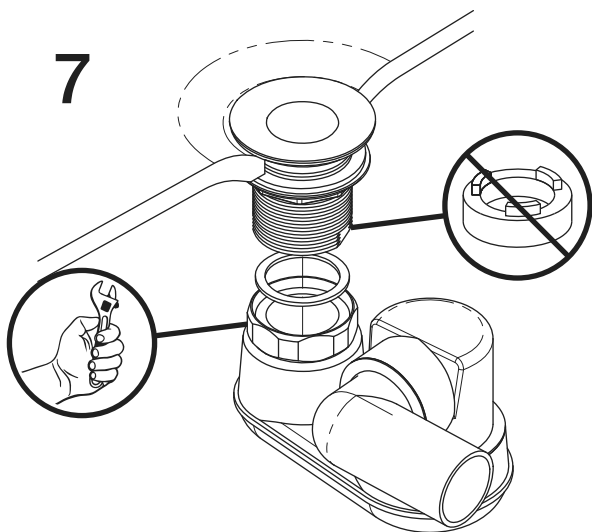
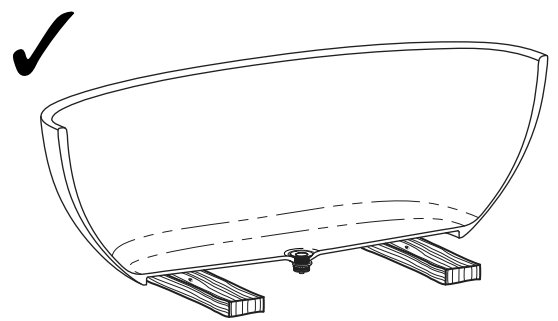
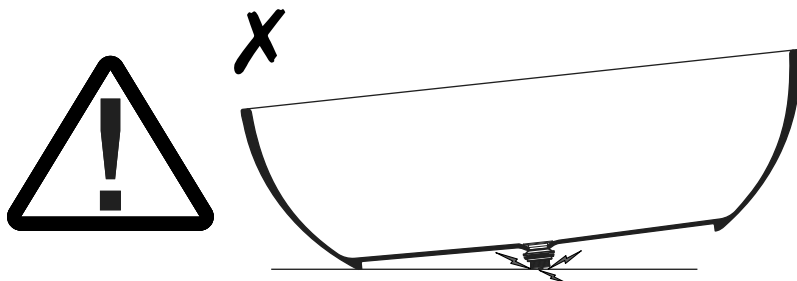
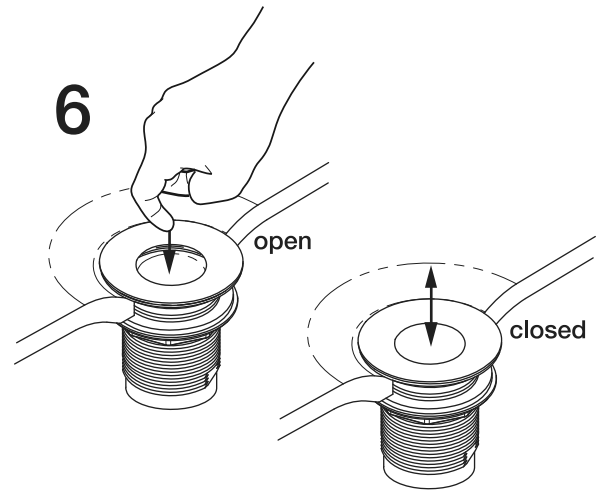
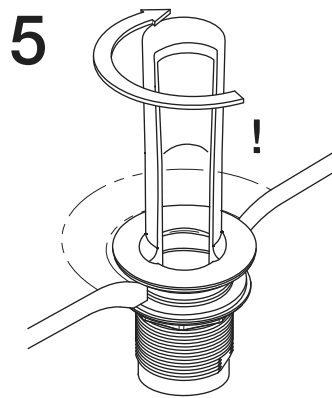
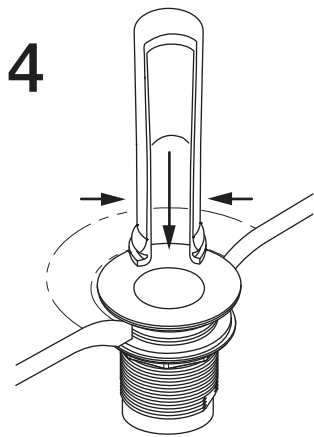
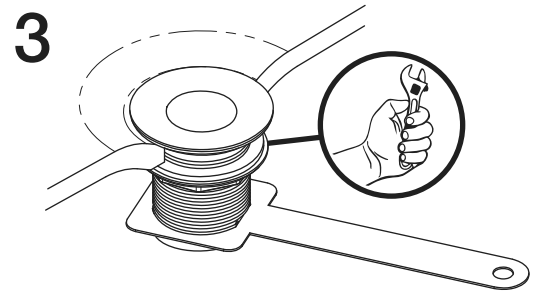
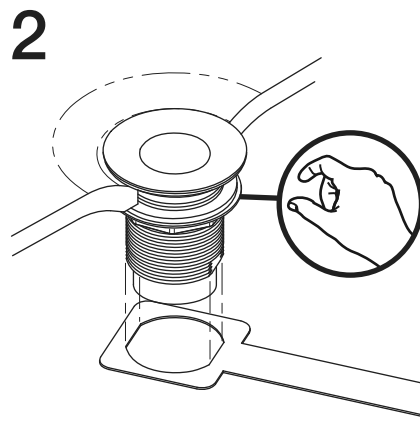
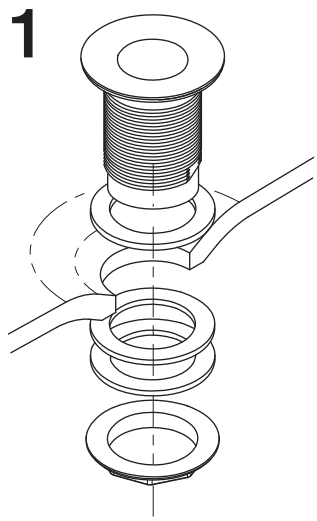



CHECK
COMPROBAR
VERIFER
ÜBERPRÜFEN

1

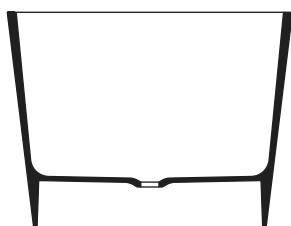

2

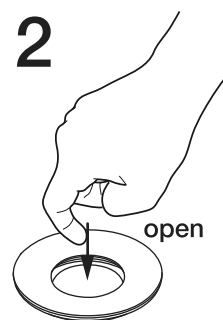

3

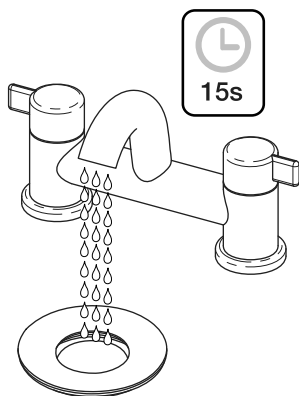

4

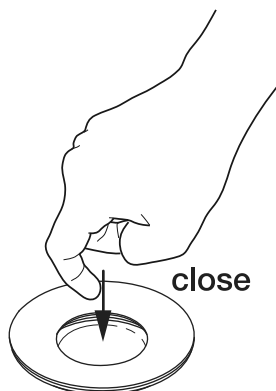

5

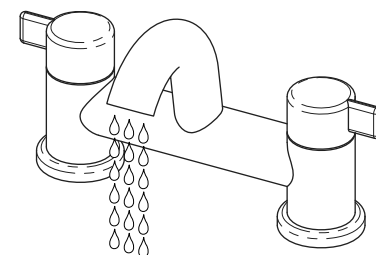

6

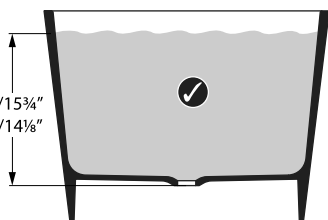

K40 = 400mm/15¾"
K36 = 360mm/14⅝"

7

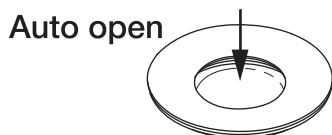

8

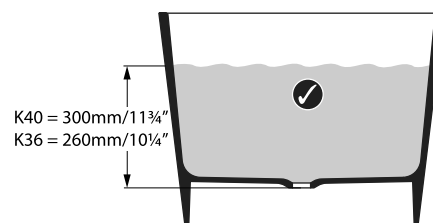

K40 = 300mm/11¾"
K36 = 260mm/10¼"

9

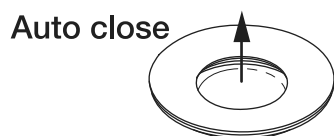

10

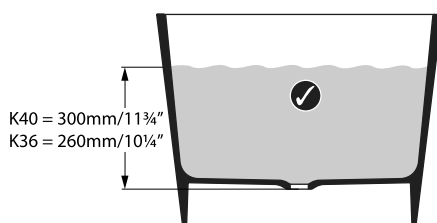

K40 = 300mm/11¾"
K36 = 260mm/10¼"

11



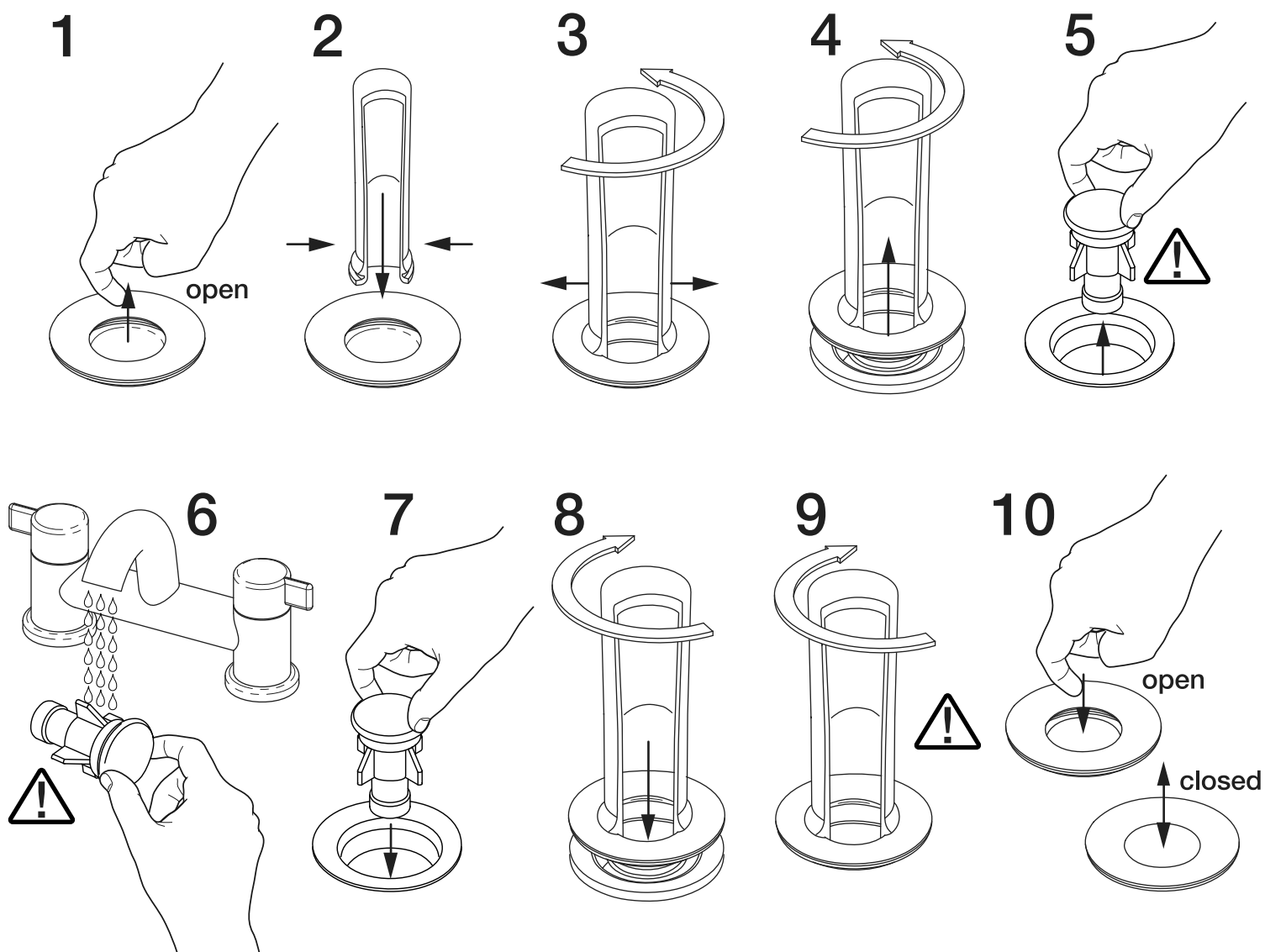

EN: Leave water flushing for 15 seconds before closing the valve and filling the bath
 ES: Deja pasar agua durante 15 segundos antes de cerrar la válvula y llenar la bañera
 DE: Lassen Sie Wasser für 15 Sekunden spülen bevor dem Schließen des Ventils und Befüllen der Badewanne
 IT: Lasciare correre l'acqua per 15 secondi prima di chiudere il tappo e riempire la vasca
 FR: Laisser l'eau couler pendant 15 secondes avant de refermer la bonde et de remplir la baignoire.a

